

Variable Capacity Commercial Split Ducted Unit

Installation and Commissioning Guide - Outdoor



Model Numbers

CRV290T

CRV330T

IMPORTANT NOTE:

Please read this manual carefully before installing or operating your air conditioning unit.



Table of Contents

01. Inspections	4
01.01. Product Inspections	4
01.02. Codes, Regulations and Standards	4
02. General Information	4
03. Safety Instructions	5
04. Installation Information	6
05. Wall Control Operation Manual Access	7
06. Outdoor Unit Dimensions and Clearances	9
06.01. Unit Dimensions and Weights	9
06.02. Minimum Service Access Areas and Airflow Clearances	10
07. Condensate Drainage Instruction	11
07.01. Suggested Minimum Slope to Ensure Correct Drainage	11
07.02. Suggested Drain Trap Details	12
08. Unit Lifting Procedure	13
08.01. Crane Lifting Method	13
08.02. Fork Lift Method	14
09. Outdoor Unit Preparation	14
10. Field Pipe Connection	16
11. Electrical Installation	21
12. Split Unit Electrical Connection	22
13. Maximum Cable Lengths	25
13.01. Wall Controller Options	25
13.02. Wiring Configuration : Recommended	26
13.03. Wiring Configuration 2 : Alternate	27
14. Wiring Connections	28
14.01. LC7-2 Wall Control Wiring Connections	28
14.02. NEO Wall Control Wiring Connections	28
14.03. LM-RS-2 Optional Sensor Wiring Connections	29
14.04. AERSS Optional Duct Sensor Wiring Connections	29
14.05. Demand Response Management (Outdoor Board)	30
15. Configuring and Commissioning Setup	31
15.01. Menu and Navigation	31
15.02. Configuring Compressor and Capacity(cnFg)	31
15.03. Configuring Control Source (CtrS)	31
15.04. Configuring Indoor Fan Setting (iduS)	32
16. Optional Output/Input Relay	40
16.01. Filter Indication Relay Output (Indoor Board)	40
16.02. Fan Run Indication Output (Indoor Board)	41
16.03. Optional Outside Air Damper Control Output (Indoor Board)	41

17. Third Party Control Input (Indoor Board and/or Outdoor Board)	41
17.01. 0-10V Analogue Input for Compressor and Indoor Fan	42
17.02. 0-10V Analogue Input for Compressor with Fixed Indoor Fan Speed	43
17.03. Analogue Input for Fixed Compressor with Fixed Indoor Fan Speed	43
17.04. 0-10V Analogue Input for Indoor Fan with Fixed Speed Compressor	44
17.05. Run and Fault Indication Output (Outdoor Board)	45
17.06. Remote ON/OFF	45
18. Indoor Fan Table and Fan Curve	46
18.01. EVA290T	46
18.06. EVA330T	48
19. Refrigerant Charging	50
20. Maintenance	53
21. Maintenance Frequency Checklist	55
22. Start Up and Commissioning Report	57

01. Inspections

01.01. Product Inspections

Check your air conditioning unit and all items against the invoice upon receiving your shipment. Inspect the unit, components and accessories for any sign of damage. If there is any damage to the unit, contact ActronAir Customer Care Department immediately on: **1300 522 722** to obtain a Goods Return Number.

Check the unit nameplate to verify the model, serial number, electrical rated specifications are correct.

01.02. Codes, Regulations and Standards

The installer and/or contractor assumes responsibility to ensure that unit installation complies with the relevant council, state / federal codes, regulations and building code standards. All electrical wiring must be in accordance with current electrical authority regulations and all wiring connections to be as per electrical diagram provided with the unit.

02. General Information

The ActronAir Ducted air conditioning units are designed for applications where superior performance, high efficiency, reliability, supply air quality and quiet operation are the prime priorities. The units are built with the latest technology, digital compressor, EC indoor fans, low-noise outdoor fans and an intelligent electronic control.

For optimum efficiency, your air conditioning unit will deliver just the right amount of cooling or heating capacity you demand. Even in extreme conditions, the unit will still supply the required demand at peak performance.

Energy Efficient Refrigeration Circuits

The ActronAir Ducted system is designed with a variable capacity refrigeration circuit that delivers only the amount of cooling or heating actually required to maintain your desired comfort at the most optimum efficiency.

The refrigeration circuit consists of:

- High efficiency variable digital scroll compressor
- Hydrophilic coated condenser coil designed for optimum performance and efficiency with corrugated fins and riffled tubing
- Hydrophilic coated evaporator coil designed for optimum performance and efficiency with lanced fins and riffled tubing
- Electronic expansion valve (EEV), to maintain efficiency at different operating conditions

Evaporator Section

The evaporator section has EC fans which deliver just the right amount of airflow, depending on requirements. The fans provide superior performance for your comfort at optimum efficiency:

- Highly efficient variable speed EC motor that uses less energy than the traditional AC motor.
- Easy indoor fan commissioning via intelligent controllers.
- Low noise operation.

Condenser Section

Uses two (2) axial fans and a digital Compressor, with the following features:

- Digital scroll compressor
- Efficient axial fans with direct drive AC motor
- Low noise operation

Electrical Section

The electrical section consists of:

- EMC filters
- Switchgears
- 3 Phase motor protection
- 7 Segment Display menu and fault code

- Adjustable indoor airflow pot
- Optional soft start, BMS card, ActronAir Group Control

Durable Design and Construction

ActronAir is an Australian manufacturer with proven high quality air conditioning products. Known for their durability and reliable performance, these products are designed and built to withstand the extreme weather conditions.

The heavy gauge zinc and galvanised steel cabinet, with powder coated epoxy enamel finish, resists the toughest conditions. The louvered outdoor coil guard protects the condenser coil from any potential damage brought by hail, stones and other solid objects that may be projected to the unit.

Hydrophilic coated condenser coil fins provide protection to your heat exchangers and enhanced heat transfer with increased performance efficiency.

System Flexibility

ActronAir units are the first choice for office, schools and other air conditioning facilities applications, both for new construction or retrofitting projects.

Sustainability and Environmentally Friendly

The air conditioning system is supplied with zero ozone depleting R-410A refrigerant, which has no phase out or replacement concern.

With cooling and heating performance capacity that are among the best in the market, the ActronAir units are the solution for the reduction of energy consumption, CO₂ emission, high fuel dependency and high network grid demand.

Refrigerant Handling and Accountability

ActronAir strongly urges that all service technicians make every effort possible to reduce the emission of refrigerants to the atmosphere. Everyone must act in a responsible manner to conserve refrigerants in accordance to the industry code of practice.

03. Safety Instructions

- Only licensed HVAC technicians* should install and service this air conditioning equipment. Improper service or alteration by an unqualified technician could result in significant and major damage to the product or property which may render your warranty null and void. Such unqualified service could also lead to severe physical injury or death. Follow all safety instructions in this literature and all warning labels that are attached to the equipment.
- Prevailing WH&S regulations must be observed and will take precedence to the safety instructions contained on this manual. Safe work practices and environment must be the paramount importance in the performance of all the service procedures.
- Ensure that unit installation complies with relevant council regulations and building code standards.
- All electrical wiring must be in accordance with current electrical authority regulations and all wiring connections to be as per electrical diagram provided.
- Secure the fans against accidental contact. Beware of pinch point and sharp edges which can cause cutting injury.
- Always wear appropriate PPE, remove any dangling jewellery and protect long hair by wearing a cap.
- Make sure that safety guards and panel covers are always firmly secured and not damaged before and during operation of unit.
- This appliance is not intended for use by young children or infirm persons unless they have been adequately supervised by a responsible person to ensure that they can use the appliance safely. Young children should be supervised to ensure that they do not play with the appliance.
- Installer must incorporate a means of electrical disconnection (isolator) in the sub-mains fixed wiring in accordance with the latest edition of the AS/NZS 3000 (also known as Australian Wiring Rules).
- Secure the power cords and control cables that goes in/out the unit. Use the cable ties provided in the control box.

*Qualifications required will be appropriate Electrical, Refrigeration and Refrigerant Handling License and Training dependent on local State/Territory regulations.

 **DANGER****Hazardous Voltage - Risk of Electrocution.**

TURN-OFF the power from main isolator before proceeding with any service work of the unit. Observe proper LOCK-OUT/TAG-OUT (LOTO) procedures for electrical appliances in order to prevent accidental switching-on of the power supply.

 **WARNING**

EC Motors are fitted with high power capacitors and can have dangerous residual voltages at motor terminals after power has been isolated. Wait at least 5 minutes after power isolation and test for any residual voltage before beginning service work.

 **CAUTION****Beware of Rotating Fans!**

Ensure that indoor and outdoor fans are isolated and have come to a complete stand still before servicing the equipment. Beware of pinch point and sharp edges which can cause cutting injury. Secure the fans against accidental contact. Always wear appropriate PPE and remove any dangling jewellery and protect long hair by wearing a cap. Ensure that no loose clothing can be caught / entangled in moving parts.

VISUAL INSPECTION AND WORK ASSESSMENT

Work areas and conditions must first be assessed and evaluated for any potential hazardous conditions. It is also important to be familiar with the unit parts and components before proceeding with any service task.

04. Installation Information

All service technicians handling refrigerant must be licensed to handle refrigerant gases.

Recover and Recycle Refrigerants

Never release refrigerant to the atmosphere! It is an offence in Australia to do so. Always recover, recycle and reuse refrigerants. When removing from the system, properly contain and identify refrigerants in its dedicated container for proper disposal and/or storage. Always consider the recycle or reclaim requirements of the refrigerant before beginning the recovery procedures. Obtain a chemical analysis of the refrigerant if necessary. Refer recovered refrigerant and acceptable refrigerant quality to existing standards and regulations.

Refrigerant Handling and Safety

Consult the refrigerant manufacturer's safety data sheet (SDS) for information on proper handling and to fully understand health, safety, storage and disposal requirements. Use the approved containment vessels and refer to appropriate safety standards. Comply with all applicable transportation standards when shipping refrigerant containers.

Service Equipment and Recovery Procedures

Always use refrigerant reclaiming equipment in order to minimise refrigerant emissions. Use equipment and methods which will pull the lowest possible system vacuum while recovering and condensing refrigerant. Equipment capable of pulling a vacuum of less than 500 microns is required.

Do not open the system to the atmosphere for service work until refrigerant is fully removed and/or recovered. Perform refrigeration system evacuation, prior to charging, in accordance with AIRAH / IRHACE Refrigerant handling code of practice.

Let the unit stand for 1 hour and with the vacuum not rising above 500 microns. A rise above 500 microns indicates a leak from the system and a leak test is required to locate and repair any leak.

 **CAUTION**

A leak test is always required on any repaired section of the refrigeration system.

Charge refrigerant into the system only after the equipment does not leak or contain moisture. Ensure that R-410A is only charged in liquid form. Take into consideration the correct amount of refrigerant charge specified for the system to ensure efficient unit operations. When charging is complete, reclaim refrigerant from charging lines into an approved refrigerant container. Seal all used refrigerant containers with approved closure devices to prevent unused refrigerant from escaping to the atmosphere. Take extra care to maintain all service equipment directly supporting refrigerant service work such as gauges, hoses, vacuum pumps and recycling equipment.

INSTALLATION PREPARATION (Pre-Installation considerations)

The following items must be considered before beginning the unit installation:

- Verify the unit capacities and ratings with the unit nameplate
- Make certain the floor or foundation is level, solid and have sufficient structural strength to support the unit and accessories weight.
- Allow minimum recommended clearances for periodic maintenance and service access.
- Allow sufficient space above the unit for the outdoor air discharge. Condenser air inlet, located on the coil side of the unit, requires sufficient airflow clearance for the optimum unit performance.
- Note the conditioned supply air and return air location. Ensure sufficient spaces are allocated for these purposes.
- Refer connection and location of condensate drain in the unit drawing and dimensions section of this manual.
- Wiring connections must be in accordance with the wiring diagram provided with the unit.
- Make sure all wirings are in accordance with local electricity authority regulations and standards.
- Do not install the unit close to an area where there is a danger of fire due to volatile, explosive, flammable and/or hazardous materials.
- Ensure that spaces around the unit are free from any obstructions for optimum unit performance.
- Installer to ensure correct size/type that main circuit breaker and cable is installed in unit sub-mains to protect the sub-mains and unit wiring.
- Installer to ensure correctly rated residual current device (RCD) is installed as per with the latest edition of the AS/NZS 3000 (also known as Australian Wiring Rules).
- Secure the power cords and control cables that goes in/out the unit. Use the cable ties provided in the control box.

CAUTION

- This outdoor unit is designed to match only with an ActronAir indoor unit as specified in the Technical Selection Catalogue.
- This unit is designed for use with R-410A refrigerant only.
- The unit is supplied with factory charged R-410A refrigerant. Be aware of all the relevant regulations concerning the handling of refrigerant.

05. Wall Control Operation Manual Access

Download from website

LC7-2

Operation Instruction can be downloaded through our website shown below.

<https://www.actronair.com.au/brochures-manuals/#operating-manuals>

NEO

Operation Instructions can be accessed through our website shown below.

<http://neo.actronair.com.au/user-guide/Components Overview>

OUTDOOR UNIT COMPONENTS OVERVIEW

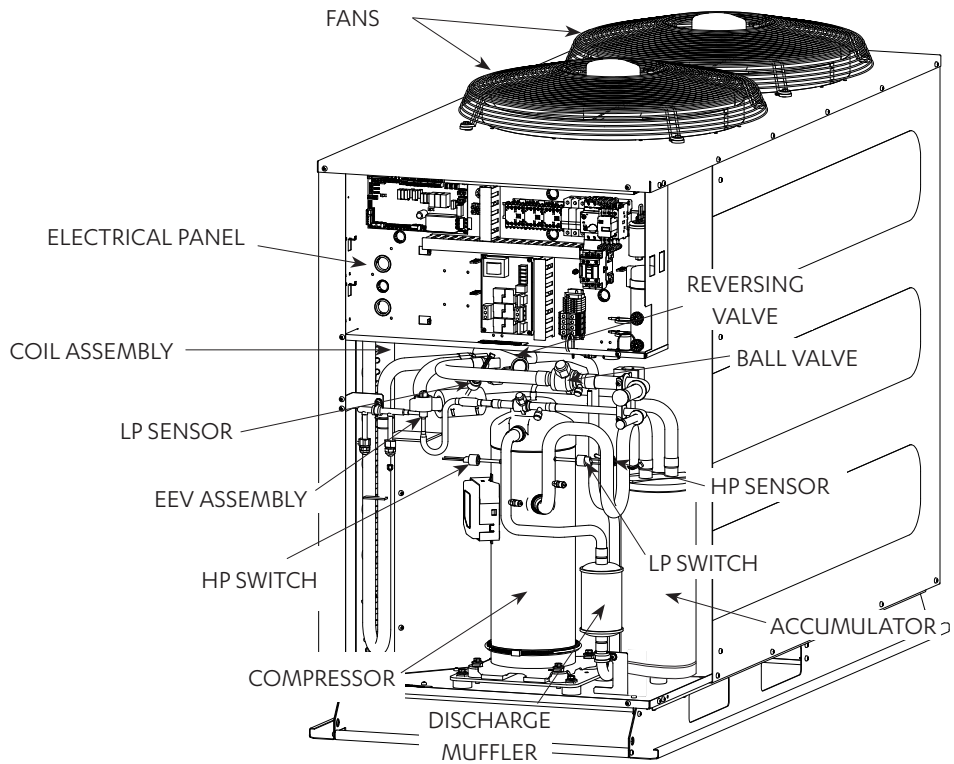

OUTDOOR UNIT ELECTRICAL PANEL OVERVIEW

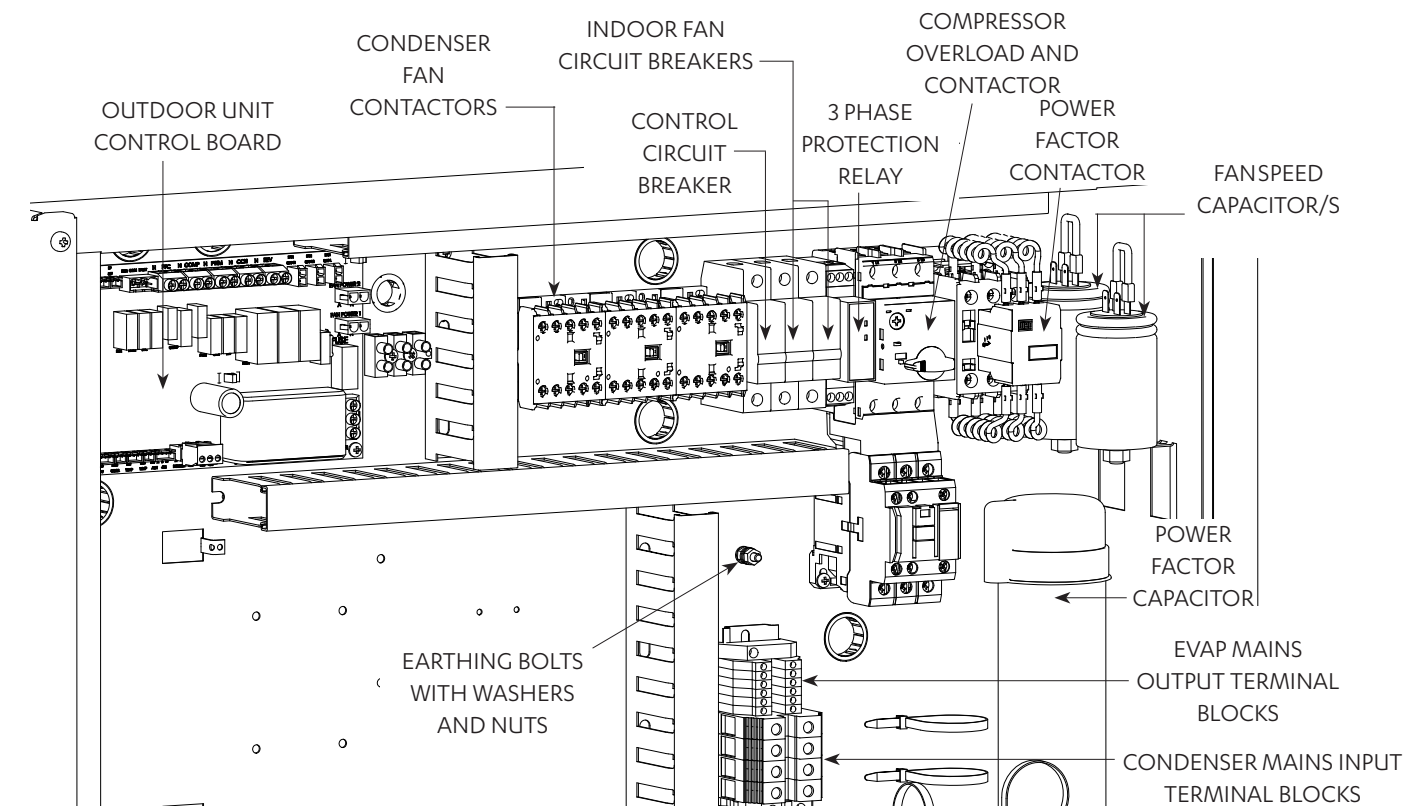

06. Outdoor Unit Dimensions and Clearances

06.01. Unit Dimensions and Weights

CRV290T / CRV330T

OVERALL NOMINAL DIMENSION (H x W x L)
= 1415 x 1840 x 820
MOUNTING DRAIN CONNECTION = DN 25mm PN12

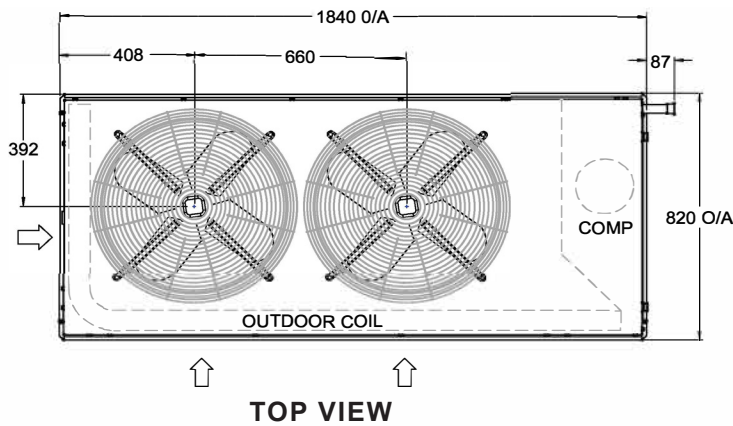

NOTES:

1. Do not scale drawing. All dimensions are in mm unless specified. Refer to corresponding unit dimensional drawing for mounting hole details.
2. Service Access Areas and Spaces for Airflow Clearances given above are suggested minimum based on the condition that the spaces around the units are free from any obstructions and a walkway passage of 1000mm between the units or between the unit and the outside perimeter is available.
3. Minimum service access areas and spaces for airflow clearances are responsibilities of the installer, ActronAir will not be held liable for any extra charges incurred due to lack of access and space for airflow.
4. Under all circumstances, condenser air must not recirculate back onto condenser coil. Keep all clearance free of any obstructions.
5. STACKING OF UNITS: Ensure that minimum airflow and clearances are met.
6. Refer to Pipe Connection Details on Specifications Sheet.
7. MTG C-C DIST = Mounting Centre to Centre Distance.
8. Use M12 bolt for feet mounting.

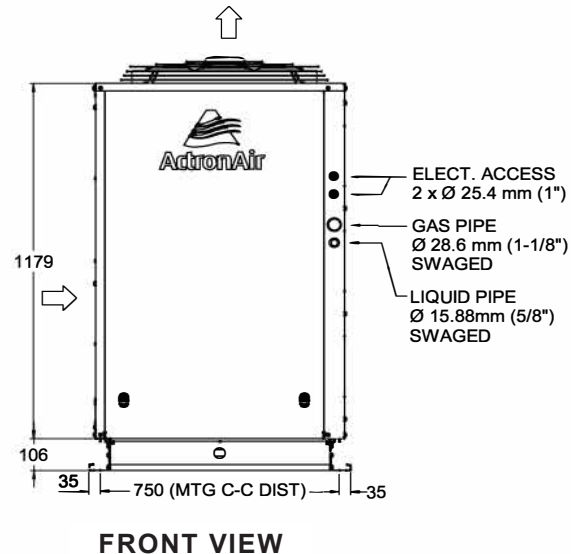
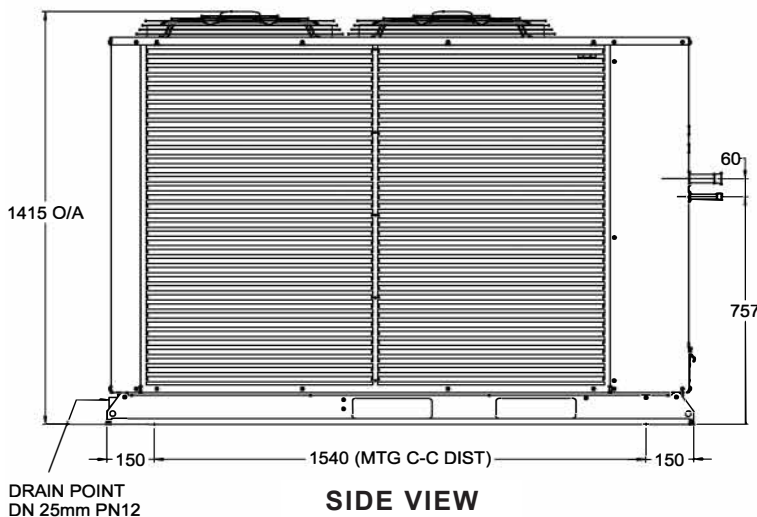
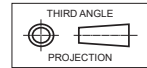

- ELECT. ACCESS
2 x Ø 25.4 mm (1")
- GAS PIPE
Ø 28.6 mm (1-1/8")
SWAGED
- LIQUID PIPE
Ø 15.88mm (5/8")
SWAGED

06.02. Minimum Service Access Areas and Airflow Clearances

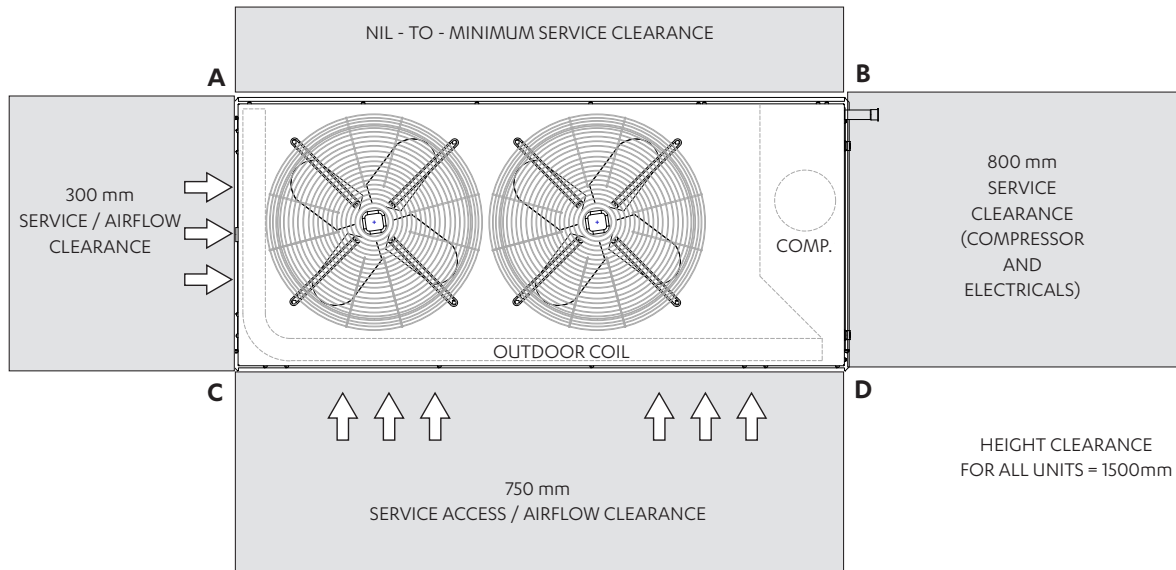

UNIT MODEL NUMBER	UNIT WEIGHT (KG)	CORNER WEIGHTS (KG)			
		A	B	C	D
CRV290T	263	48	79	61	75
CRV330T	292	52	87	66	87

07. Condensate Drainage Instruction

NOTES

- Do not use pipes or tube coming out from the unit to lift the unit.
- Support drain line for long pipe run.
- Parts for the Condensate Trap are not supplied with the unit.
- Refer to unit dimension page for specification of drain connectors.
- Test condensate drain installation to ensure that water flows freely and does not leak. Also check that the drain tray does not overflow.
- CRV850T/960T model shown. All drawings are for illustration purposes only. Actual unit may vary depending on the model.

07.01. Suggested Minimum Slope to Ensure Correct Drainage

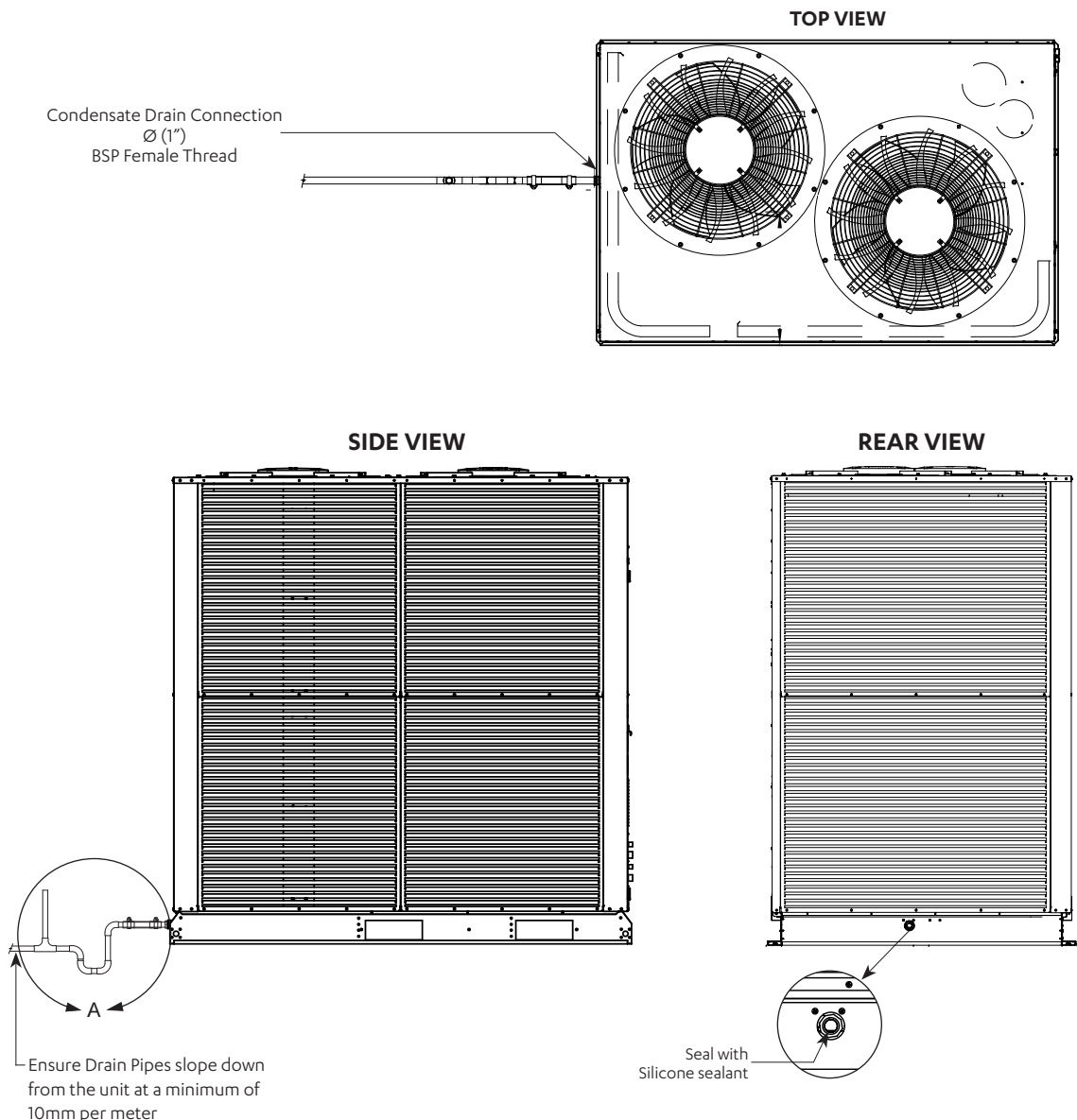

07.02. Suggested Drain Trap Details

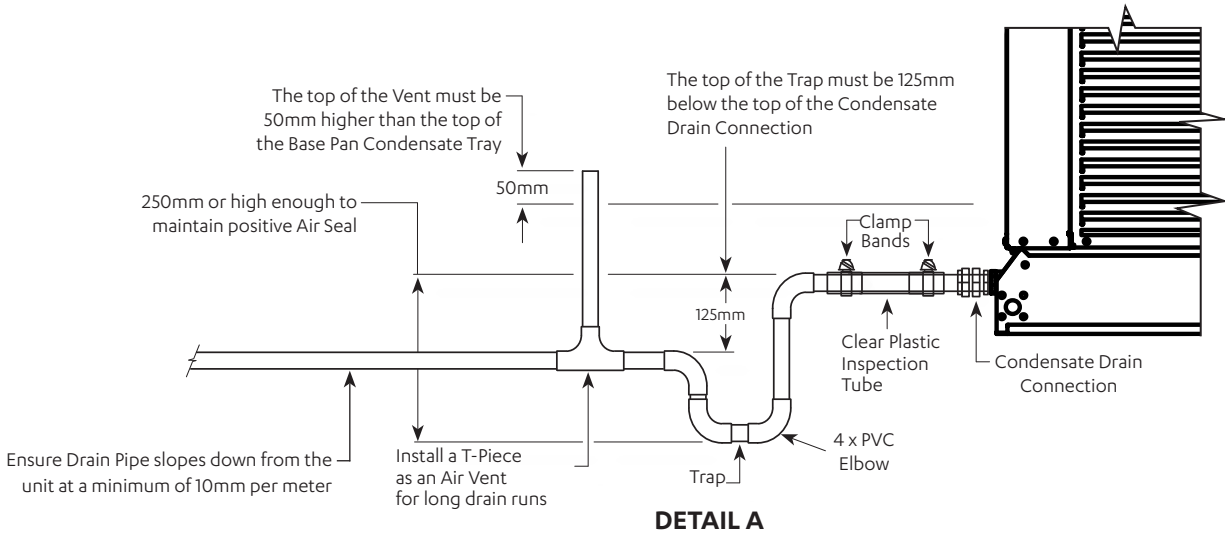

08. Unit Lifting Procedure

WARNING

WH&S regulations must be observed and will take precedence during lifting process.

08.01. Crane Lifting Method

Crane lifting method is recommended for high rise lifting

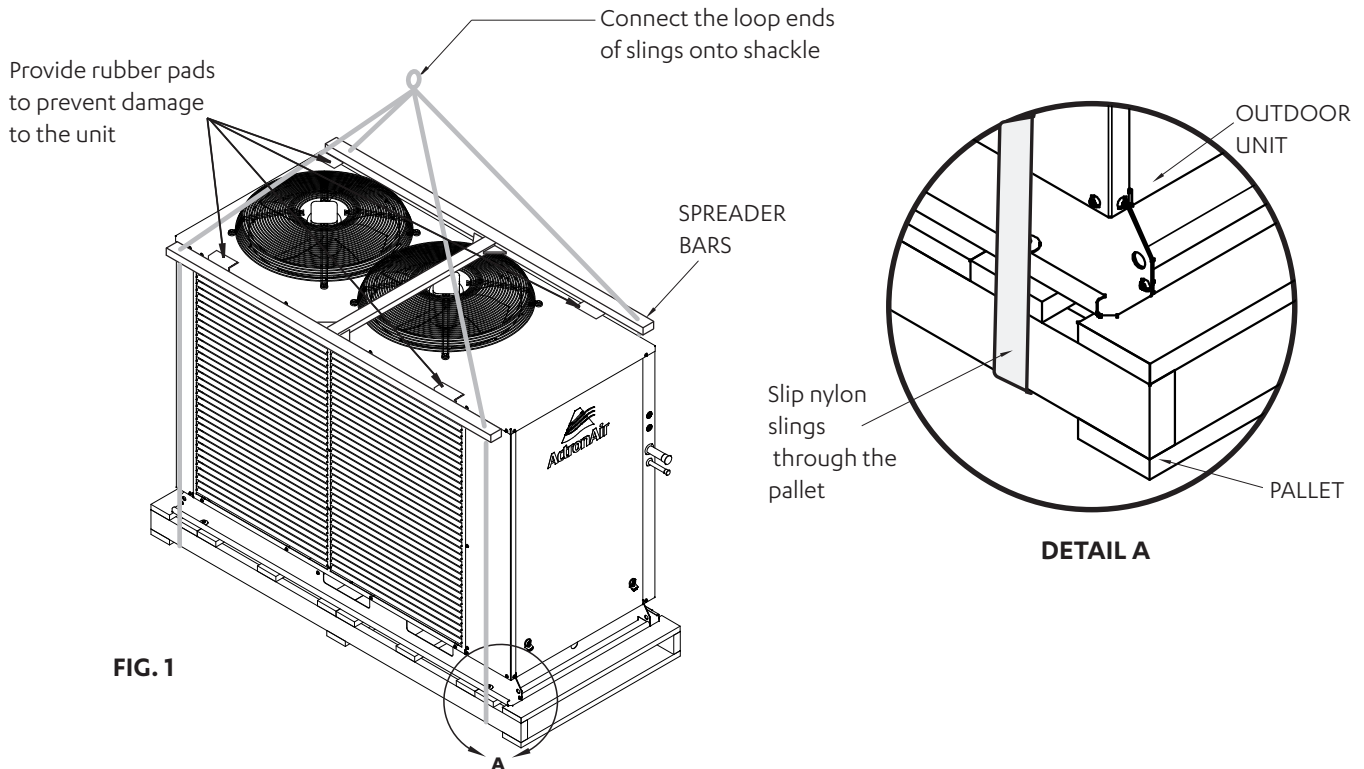

Equipment Required For Crane Lifting:

1. 1 x shackle
2. 2 x nylon slings
3. Spreader bars

NOTE

Refer to Unit Dimension and Weight section for unit weight before selecting shackles and slings.

Procedure:

1. Slip nylon slings through the pallet as shown in Fig. 1.
2. Use a Bow or Dee shackle to connect the slings.
3. Ensure slings are protected by rubber pads or similar if slings are draped across unit edges, corners, or air grilles. This will prevent the unit from being damaged during lifting.
4. SPREADER BAR must be used when lifting the unit. Ensure that the spreader bar is slightly larger than the base.
5. Test lift the unit to determine exact unit balance and stability before hoisting it to the installation location.

08.02. Fork Lift Method

⚠ DANGER

Make sure rigging equipment, accessories and plant are sufficiently and safely capable to lift the unit in order to prevent potential damage to property, severe personal injury or death. Please check unit weight and weight distribution points on unit drawing dimensions section.

PROCEDURE:

1. To move the unit around with a forklift, insert the fork tines through the pallet, as shown in Fig. 2.
2. Only fork the unit through compressor end or side of the unit. (See illustration for location of compressor end).

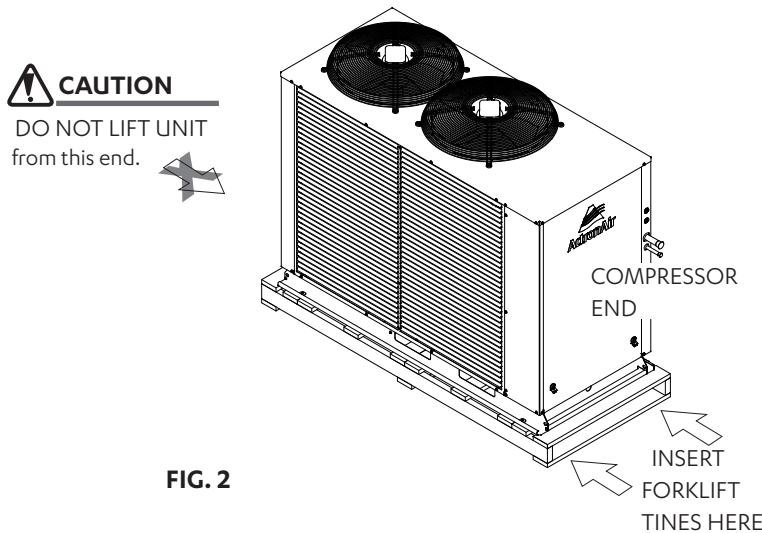

⚠ CAUTION

Length of fork lift tines must pass the unit middle section, in order to safely carry the unit.

09. Outdoor Unit Preparation

NOTE

It is important to remove the shipping blocks before unit operation.

Step 1. Remove Access Panel, as shown below:

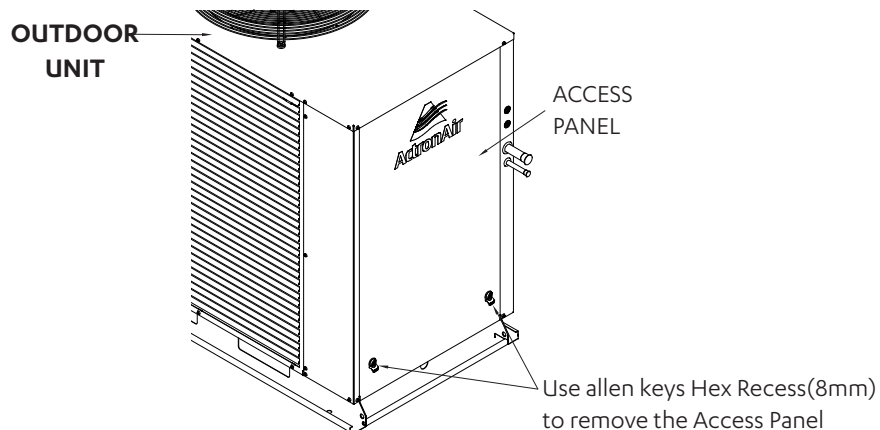

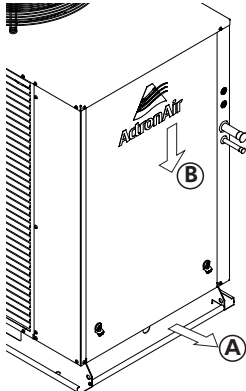
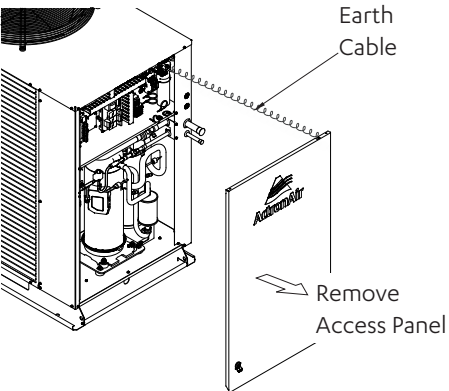
Remove access panel as illustrated below.	Do not disconnect Earth Cable.
 <p>Removal Order:</p> <ul style="list-style-type: none"> (A) Pull-Out 20mm (B) Pull-Down to remove Access Panel-Electrical 	 <p>Earth Cable</p> <p>Remove Access Panel</p>

WARNING

- There is an earth cable attached to the access panel. This must be disconnected first to fully remove the access panel.
- You must re-connect the earth cable when re-assembling the access panel.
- Live electrical within enclosure. Isolate electrical supply before removing panels. Authorised technicians access only.
- Follow the procedure below when removing the shipping blocks.

Step 2. Remove the Shipping Blocks before installing Interconnection Field Pipes.

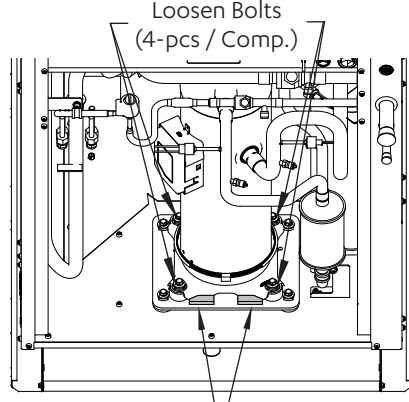
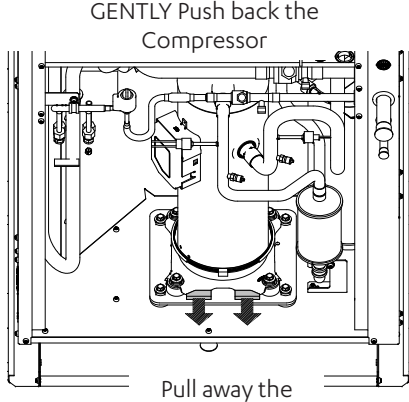
Loosen the set bolts that hold the compressors down onto the unit (4 pcs)	Remove Shipping blocks as shown below.
 <p>Loosen Bolts (4-pcs / Comp.)</p> <p>Shipping Blocks</p>	 <p>GENTLY Push back the Compressor</p> <p>Pull away the Shipping Blocks</p>

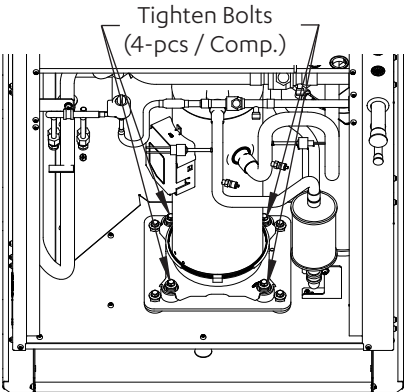
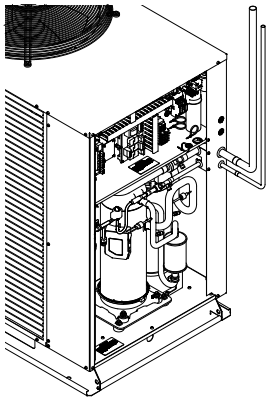
<p>Tighten back the set bolts that hold the compressors down onto the unit (4 pcs)</p>	<p>Braze refrigeration piping. Refer to piping sections for details of field pipe sizes and piping installation procedure.</p>
	

10. Field Pipe Connection

⚠ CAUTION

The units described in this guide uses R-410A refrigerant

This operates at a pressure approximately 1.6 times higher than a similar systems using R-22. When installing equipment using R-410A refrigerant, there are number of standards that must be met:

- The system of this unit operates with Polyolester (POE) oil that rapidly absorbs moisture.
- The maximum time any system can be opened to atmosphere is 15 minutes.
- It is important to work with absolute cleanliness.
- Brazing must be done with the use of Nitrogen to avoid carbon deposits into the pipes.
- The system must be evacuated thoroughly to 500 microns (see evacuation procedure).
- The system must always be charged with R-410A refrigerant in liquid state.
- Never allow R-410A refrigerant to vent into the atmosphere. It is an offence to release refrigerant in Australia.
- Always reclaim refrigerant using equipment and container dedicated for R-410A system use only.
- Only qualified persons are allowed to perform any work described in this guide.
- All work must be carried out in accordance with Australia and New Zealand refrigerant handling code of practice.

Maximum allowable total equivalent field pipe length is 60 metres, see diagram below. This includes all the equivalent pipe fitting losses and vertical height difference. Vertical height difference must not exceed 20 metres. Table 1 below shows the equivalent straight pipe length of elbow fittings.

EQUIVALENT STRAIGHT PIPE LENGTH OF ELBOW FITTINGS (METRES)				
PIPE SIZE NOMINAL DIAMETER	90° LONG RADIUS ELBOW	90° SHORT RADIUS ELBOW	45° LONG RADIUS ELBOW	45° SHORT RADIUS ELBOW
9.52 (3/8")	0.24	0.36	0.09	0.14
15.88(5/8")	0.30	0.45	0.15	0.23
19.05 (3/4")	0.40	0.60	0.18	0.27
22.22 (7/8")	0.46	0.69	0.21	0.32
25.4 (1")	0.52	0.78	0.24	0.36
28.56 (1-1/8")	0.55	0.83	0.27	0.41

Selected field pipe sizes must match the recommended sizes in table above. If the installation requires different field pipe diameter due to different application condition other than recommended, contact ActronAir for advice. Most of unit pipe connections are factory swaged to easily fit to the recommended field pipe diameter. When it is required to install other refrigeration devices, such as refrigerant drier, solenoid valve and the like, include the equivalent straight pipe length of the device in the calculation of total equivalent field pipe length.

Both pipes are required to be insulated.

Improper insulation can result in condensation forming on the pipework's surface, potentially leading to dripping condensation.

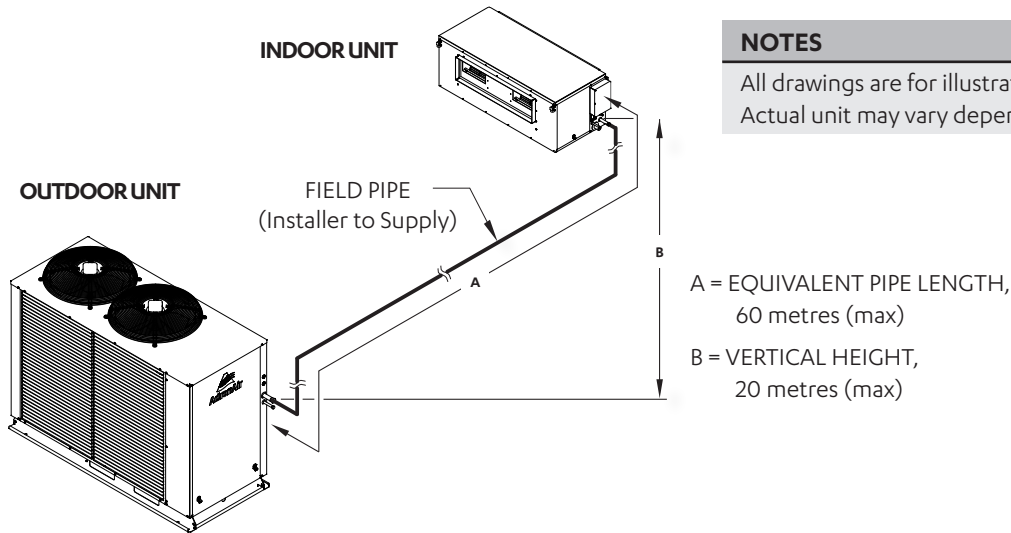

Example of Total Equivalent Field Pipe Length Calculations

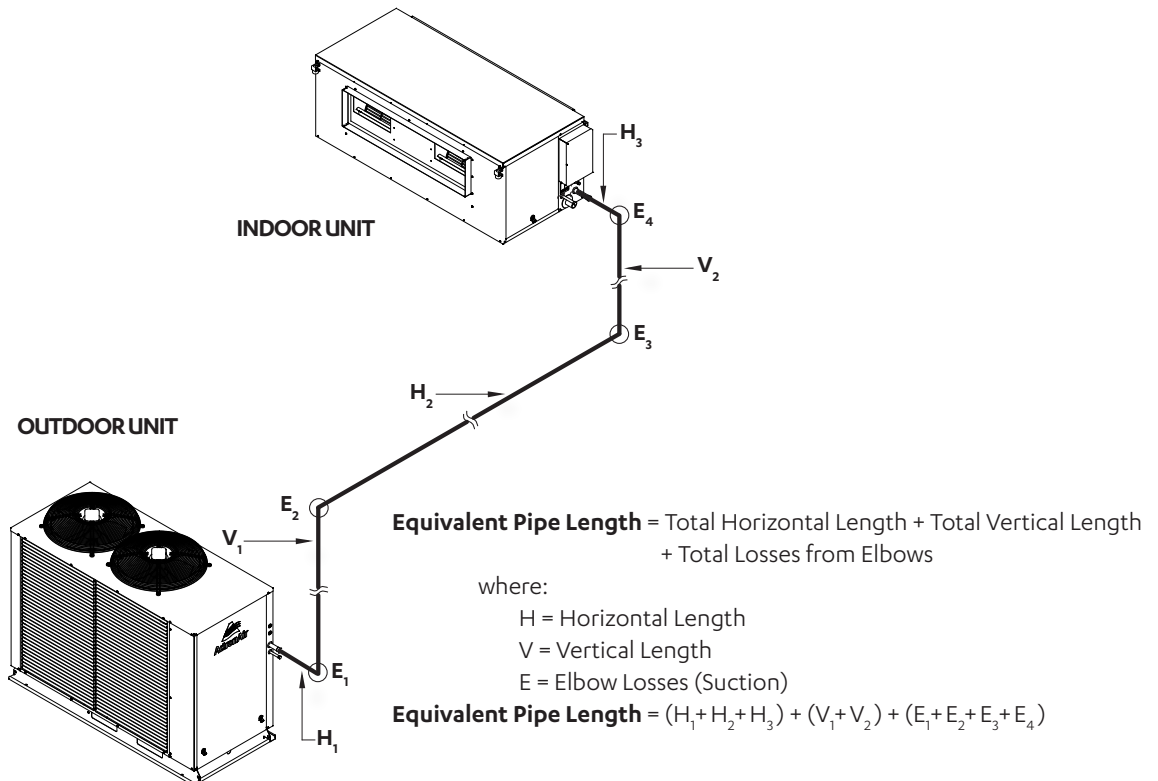

 **CAUTION**

Above illustration shown as calculation examples only. It is the responsibility of the Installer to design an efficient refrigeration piping lay out for optimum unit performance.

TABLE 2: REFRIGERATION PIPING		
Outdoor Model		CRV290T/330T
Indoor Model		EVA290T/330T
Equivalent Pipe Length Range	metres	0 - 60
Maximum Vertical Height Differential *	metres	20
Field Pipe Size		
Liquid Line	mm (inch)	15.88 (5/8)
Gas Line	mm (inch)	28.58 (1-1/8)
Outdoor Pipe Size		
Liquid Line	mm (inch)	15.88 (5/8) swaged
Gas Line	mm (inch)	28.58 (1-1/8) swaged
Indoor Pipe Size		
Liquid Line	mm (inch)	15.88 (5/8) swaged
Gas Line	mm (inch)	28.58 (1-1/8) swaged

* Included in maximum field pipe

 **CAUTION**

Brazing joints should only be performed whilst purging Nitrogen through the system. Failure to do so will cause carbon deposits to be left on the internal pipe surface, that in turn can cause system failure and void of warranty.

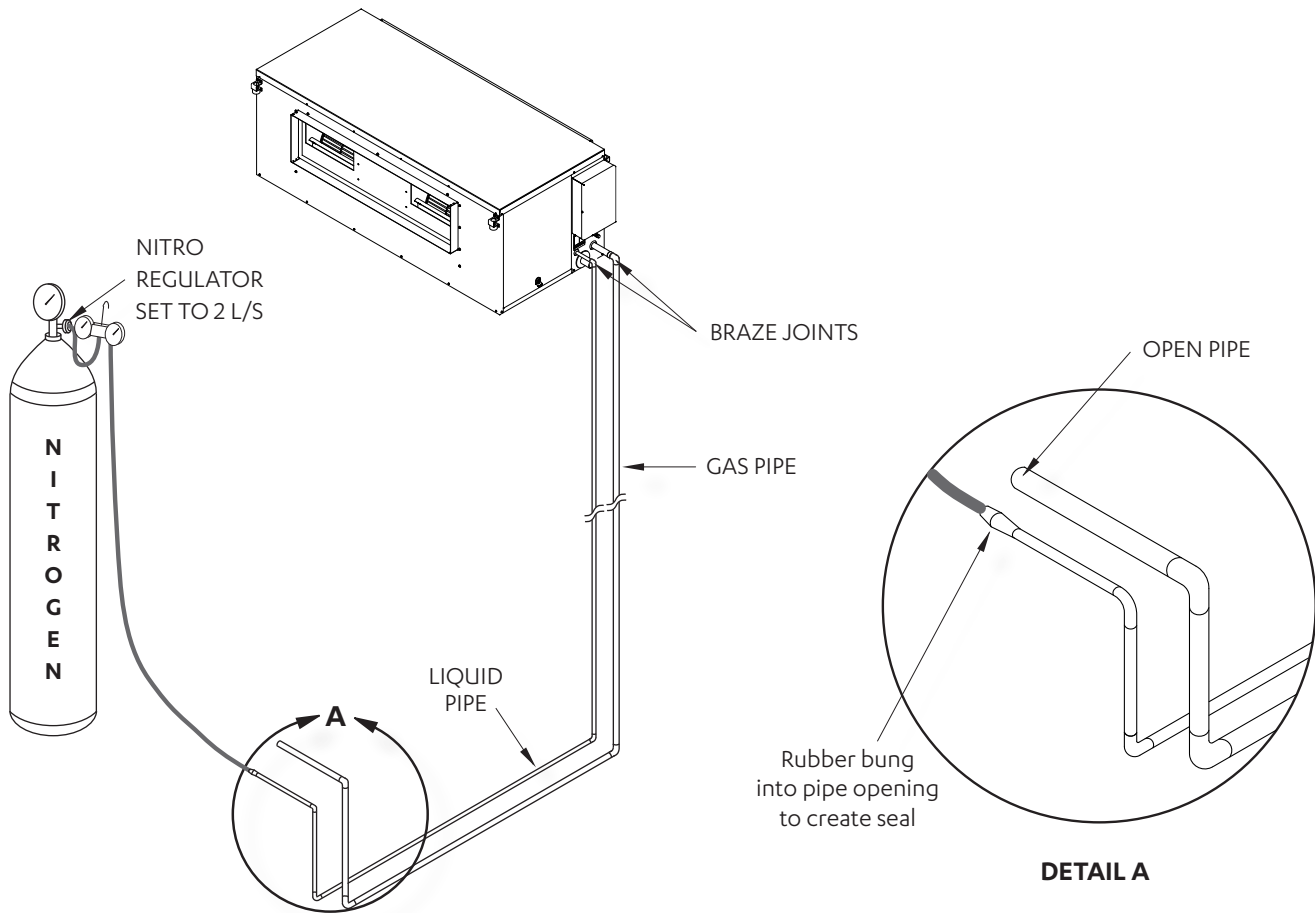

Installing interconnecting pipe work to indoor, nitrogen bleed procedure (First fit or rough in stage only)

1. Run interconnecting pipe work from condenser location to evaporator.
2. Release pressure in evaporator and remove caps.
3. Fit copper tube into tail, set nitro bottle and regulator up at condenser end of pipe work.
4. Fit nitrogen line into liquid line with rubber bung to seal the connection. The seal will prevent air being sucked into pipe work.
5. Leave suction line open, set nitro regulator for nitrogen to flow through pipe work at 2 l/s flow rate @20kPa.
6. Braze required joints as quick as possible. See Diagram Above.

Installing interconnecting pipe work to outdoor, nitrogen bleed procedure (First fit or rough in stage only)

1. Starting with circuit 1 system, remove piping caps from the condenser and fit pipe work into tails.
2. Fit nitro hose onto suction ball valve and fit open hose onto liquid line post valve.
3. Set nitrogen regulator to 2 l/s flow rate through pipe work and evaporator.
4. Braze remaining joints as quick as possible.
5. Allow the brazed joints to cool and conduct leak test in the connections.

Pressurize Testing

Pressure test the system between 2500kPa and the system's maximum kPa as determined in **AS/NZS 5149.2:2016, Clause 5.2.2.1 Maximum Allowable Pressure**. Ensure pressure is held for no less than 1 hour.

NOTES

- Any non-condensable product left in the system can cause the pressure in the high side of the system to increase and in turn, the compression temperature to rise.
- Moisture will result in adverse reaction in the refrigerant circuit.
- The POE oil used in the R-410A compressor is hygroscopic, which means that it absorbs moisture from the air. To prevent chemical reactions in the system, any moisture must be removed at all costs.
- **Oxygen (air) reacts with the compressor oil and can lead to faults such as compressor failure.**

See Diagram Below:

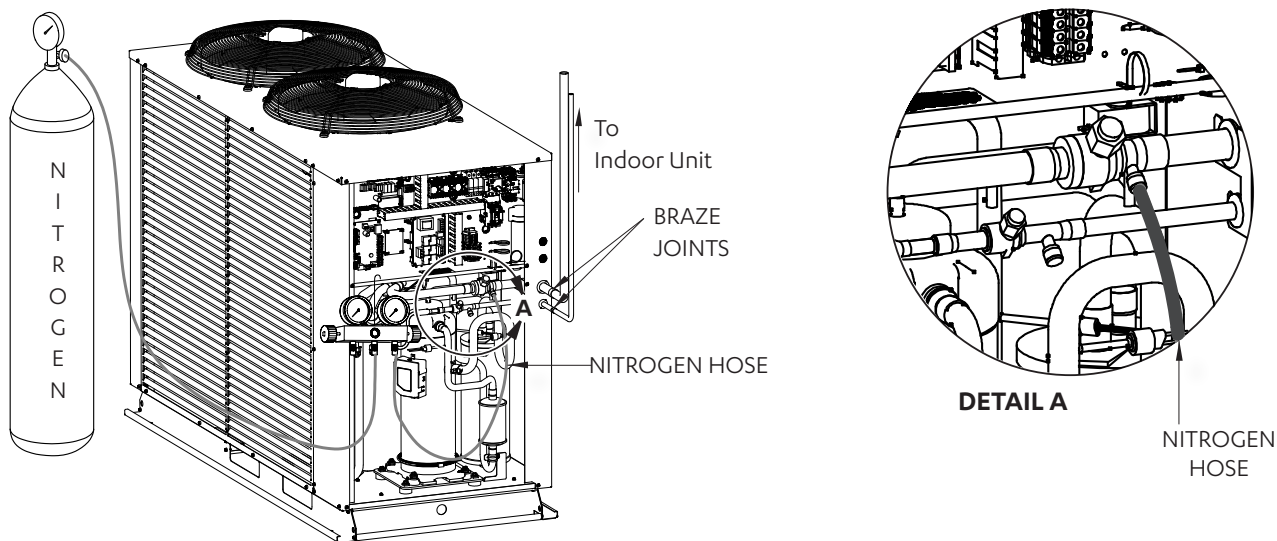

Evacuation Procedure (Triple Evacuation)

1. Fit service gauges to the ball valves (liquid line service valve and suction line service valve).
2. Evacuate the system to 1000 microns.
3. Check vacuum with vacu stat. Break the vacuum with dry Nitrogen to 100kPa
4. Release Nitrogen pressure. Evacuate to 500 microns.
5. Check vacuum with vacu stat. Break the vacuum with dry Nitrogen to 100kPa
6. Release Nitrogen pressure. Evacuate to 500 microns.
7. Check vacuum with vacu stat. Let the unit stand for 1 hour and with the vacuum not rising above 500 microns.
8. Open valve

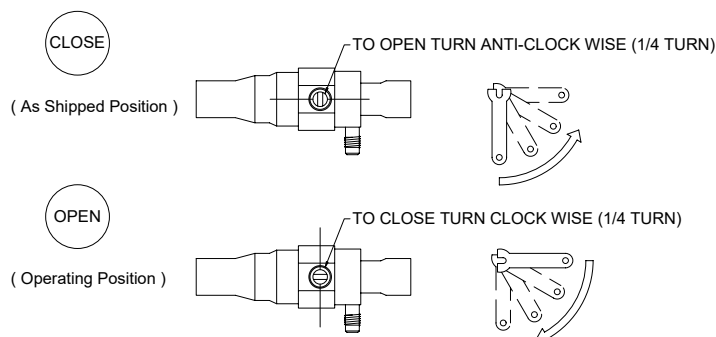

11. Electrical Installation

All electrical work must be carried out by a qualified and licensed technician. Make sure all wiring is in accordance with local wiring rules. Wiring connections should be made in accordance with the wiring diagram provided.

DANGER

Live Electrical Supply !

During installation of your air conditioning unit, it may be necessary to work in close proximity to live electricity. Only licensed electricians are allowed to perform these tasks.

Follow all electrical safety precautions when exposed to live electrical components.

CAUTION

Static Sensitive Electronic Devices !

- DO NOT handle electronic devices unless you are wearing an Anti-Static Wrist Strap that is connected to a GOOD EARTH. Failure to protect the electronic devices from static electricity may cause unreparable damage.
- Static damaged electronic devices are NOT COVERED for replacement under warranty.

Wiring Diagram

The wiring diagram specific for your air conditioning system is located on the inside panel of the control access door. Always refer all wiring installation, servicing and troubleshooting of this equipment to this diagram to ensure correct electrical connection are satisfied.

Supply and Power Requirements Procedure

It is the installer's responsibility to provide power supply wiring to the mains supply terminal strip of the outdoor unit. Make sure all wiring are in accordance with local wiring rules. Wiring should conform to all current electrical authority regulations and all wiring connections to be as per electrical diagram provided with the unit.

- Confirm that the power supply available is compatible with the unit nameplate ratings. The supply power must be within +6% to -6% of the rated voltage as per AS60335.1.
- Protect electrical service from over current and short circuit conditions in accordance with the latest edition of the AS/NZS 3000 "Australian / New Zealand Wiring Rules". Size protection devices according to the electrical data of the unit and the table below.
- Installer to connect an appropriate load break (AC3) isolator in sub-mains wiring.
- Secure any power and control cables that enters in/exits out of the unit. Use the cable ties provided in the main electrical panel.

Provide proper unit earth in accordance with local and national codes.

Main Voltage Balance Requirement

Check the voltage at the mains supply terminals to determine if it is balanced. Voltage imbalance on three phase systems can cause motor overheating and premature failure. The maximum allowable imbalance is +2.0%, should voltage imbalance exceed this value, check unit wiring connections to locate and rectify faults or contact local supply authority.

12. Split Unit Electrical Connection

DETAILED WIRING DIAGRAM IS PROVIDED WITH THE UNIT

Outdoor Unit: Located at the back of electrical/compressor access panel.

Indoor Unit: Located at the back of electrical box cover.

- ① MAINS WIRING (400VAC)
(Three Phase + Neutral + Earth) 50Hz
- ② INTER-CONNECTING POWER CABLE (400 VAC)
(Three Phase + Neutral + Earth) 50Hz
- ③ DATA CABLE TO WALL CONTROL
(Cat5E UTP (AWG 24) Data Cable)
- - - - ④ EXTRA LOW VOLTAGE DATA CONTROL WIRING
(2 Core (1 Pair) Twisted Pair, 7/0.30 (0.5mm²) Shielded Data Cable)

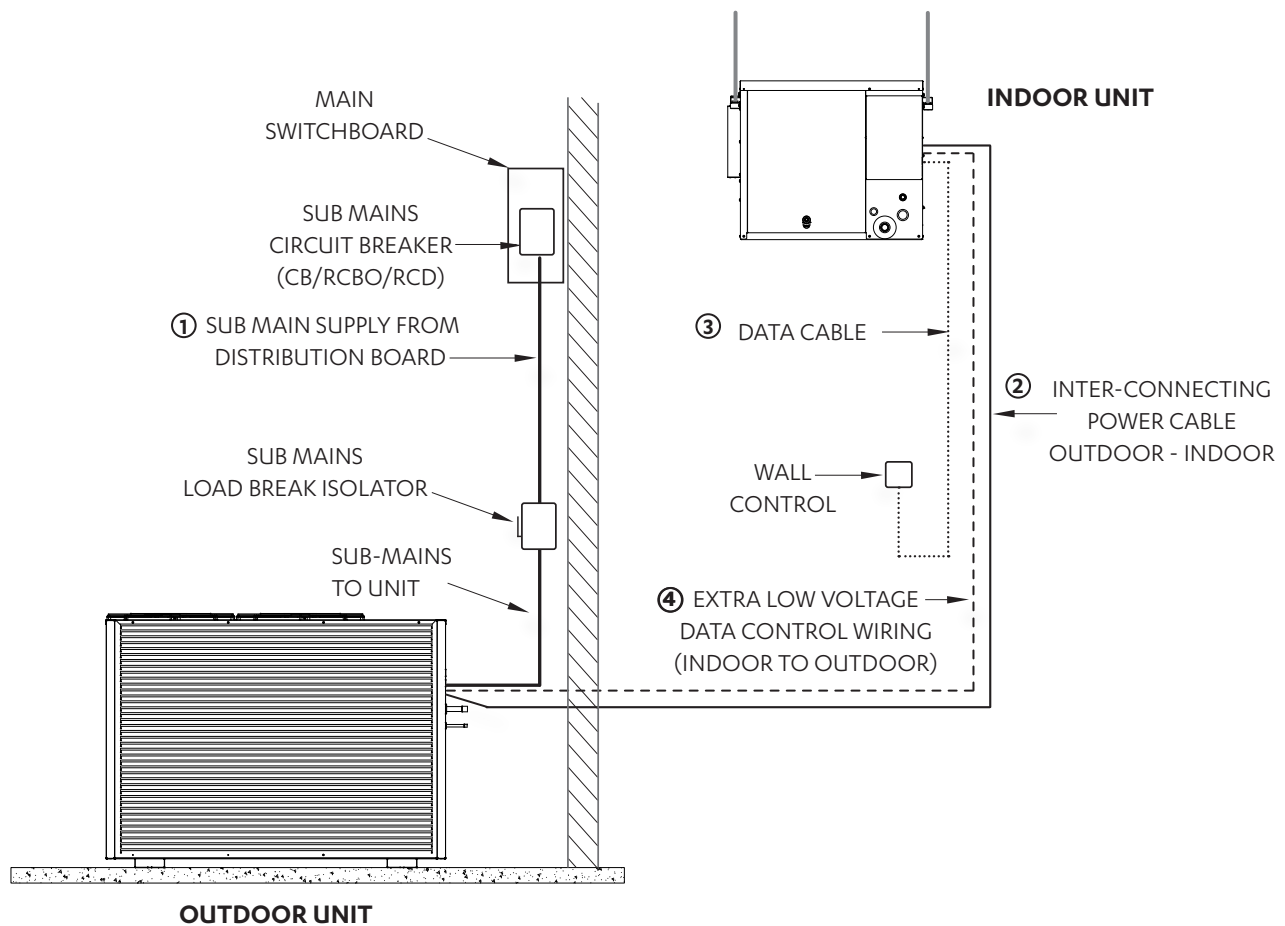

NOTES

- To minimise noise interference, Data and Power cable clearance should be maintained as much as possible (minimum 300mm).
- Above Images used for illustration purposes only.

2 Core Twisted Data Cable Shielding Instructions

(ActronAir Part Number: AEDC2)

NOTES

- Maintain the twist of the core wires up to the Green Terminal Plug.
- Maximum strip length of outer insulation to the Green Terminal Plug is 50mm.
- Make sure the cable colours used for the Data Terminal in Outdoor Unit match the Data Terminal in Indoor unit.

Outdoor Unit Data Terminal (Green Plug)

“Terminal A” - White Wire

“Terminal B” - Black Wire

“Terminal G” - Shield Wire

Indoor Unit Data Terminal (Green Plug)

“Terminal A (+)” - White Wire

“Terminal B (-)” - Black Wire

“Terminal G” - Shield Wire

Insert data cable through the lower snap bushing and first cable tie on the right hand side of the electrical panel.

Connect core wires and shield wire into the Outdoor Board green terminal plug marked “INDOOR A, B and G”.

(Refer to unit wiring diagram for complete wiring connection details).

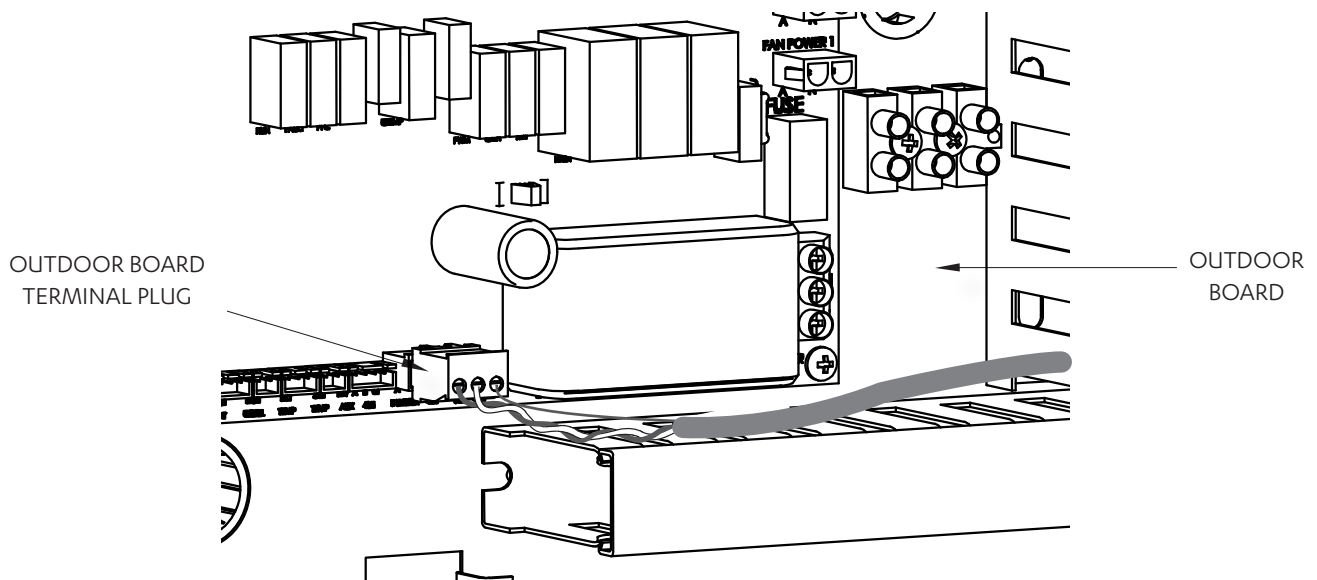

Circuit Breaker Size Recommendation

Model	Circuit Breaker Size Amps
CRV290T / CRV330T	32.0

Refer to latest edition of AS/NZS 3000 or AS/NZS 3008 Australian/New Zealand Wiring Rules to determine required cable size.

13. Maximum Cable Lengths

13.01. Wall Controller Options

Maximum of three (3) wall controllers in below combinations is allowed on unit. See below table.

Combinations	Wall Controllers		
	WC 1	WC 2	WC 3
1st Option	NEO		
2nd Option	NEO	NEO	
3rd Option	NEO	NEO	LC7-2
4th Option	NEO	LC7-2	
5th Option	NEO	LC7-2	LC7-2
6th Option	LC7-2		
7th Option	LC7-2	LC7-2	
8th Option	LC7-2	LC7-2	LC7-2

NOTES

- NEO - Available in White (NTW-1000) and Black (NTB-1000) colours.
- LC7-2 - Available in White and Grey colours.
- In the instance of a combination of NEO and LC7-2 being connected together, the NEO will always need to be addressed as C1.

13.02. Wiring Configuration : Recommended

NOTES

- Diagram shown below is a general representation only. Refer to individual unit wiring diagram for complete wiring connection details.
- Long runs beside Mains cables or TV antenna cables should be avoided.
- Wiring configuration for LR7-1 and LC7-2 wall controller is the same.
- Daisy connection is not allowed for the NEO wall controller.
- Two Ferrite Clips*, if supplied, are to be placed 200mm and 400mm from the NEO controller.

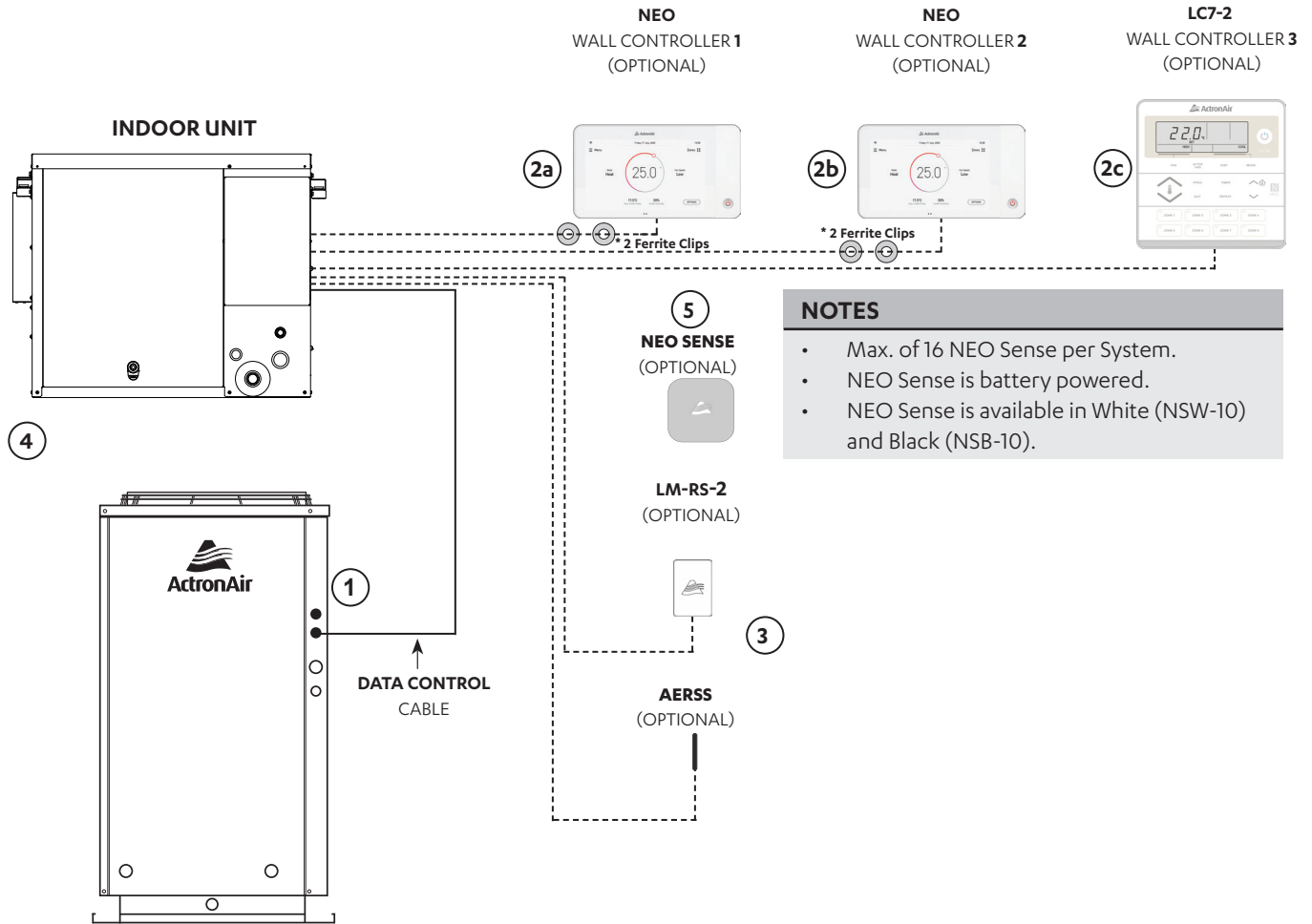

Item	Description	Maximum Cable Length
1 to 4	Outdoor PCB to Indoor PCB	100 m
4 to 2a, 4 to 2b,	Indoor PCB to Wall Controller	90 m
4 to 2C	Indoor PCB to Wall Controller	100 m
4 to 3	Indoor PCB to Remote Sensor	100 m

Description	Cable Type
LC7-2 and NEO Field Control Wiring	Cat5E UTP (AWG 24) Data Cable
Indoor to Remote Sensor	Cat5E UTP (AWG 24) Data Cable
Indoor to Outdoor Data Cable	2 Core (1 Pair) Twisted Pair, 7/0.30 (0.5mm ²) Shielded Data Cable

13.03. Wiring Configuration 2 : Alternate

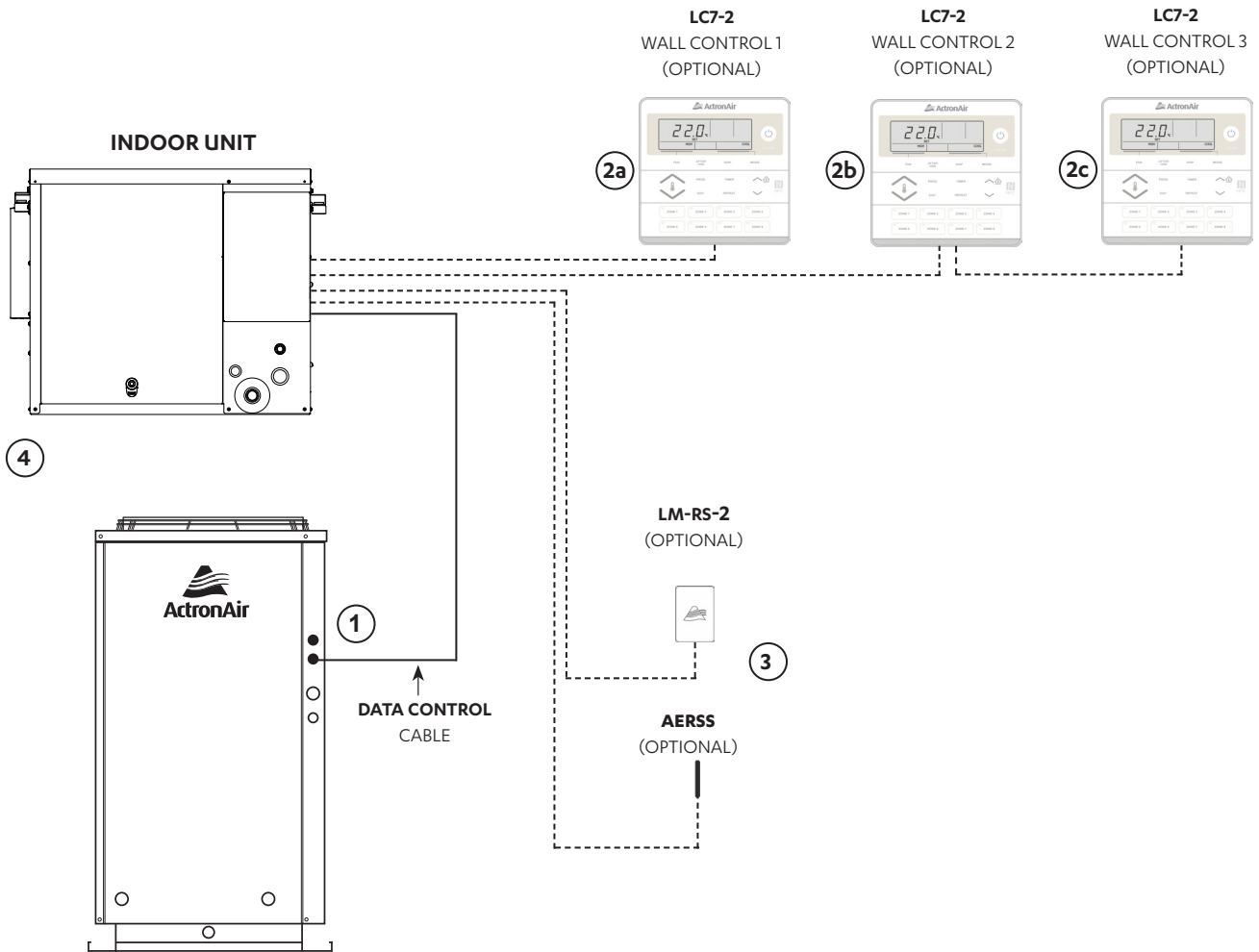

NOTES

- Diagram shown above is a general representation only. Refer to individual unit wiring diagram for complete wiring connection details.
- Long runs beside Mains cables or TV antenna cables should be avoided where possible.

Item	Description	Maximum Cable Length
1 to 4	Outdoor PCB to Indoor PCB	100 m
4 to 2a	Indoor PCB to Wall Control 1	100 m
4 to 2c	Indoor PCB to Wall Control 3 (last controller)	75m total (Daisy Chain)*
4 to 3	Indoor PCB to Remote Sensor	100 m

* Maximum Daisy Chain connection is up to 2 wall Controls.

Description	Cable Type
LC7-2 Field Control Wiring	Cat5E UTP (AWG 24) Data Cable
Indoor to Remote Sensor	Cat5E UTP (AWG 24) Data Cable
Indoor to Outdoor Data Cable	2 Core (1 Pair) Twisted Pair, 7/0.30 (0.5mm ²) Shielded Data Cable

14. Wiring Connections

14.01. LC7-2 Wall Control Wiring Connections

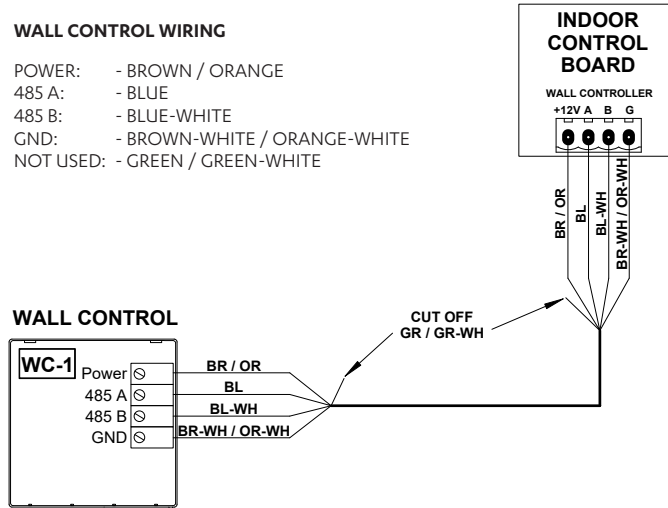

14.02. NEO Wall Control Wiring Connections

NOTE

Two FERRITE CLIPS, if supplied, should be installed 200 mm away and FERRITE 2 should be 400 mm away from the Wall Control.

14.02.01. NEO RJ45 Wiring

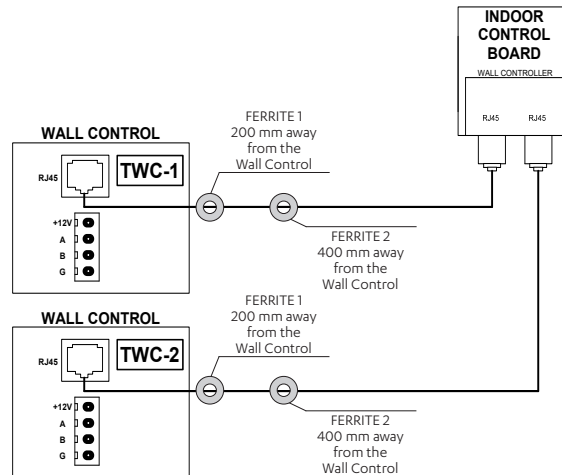

14.02.02. NEO Hard Wiring

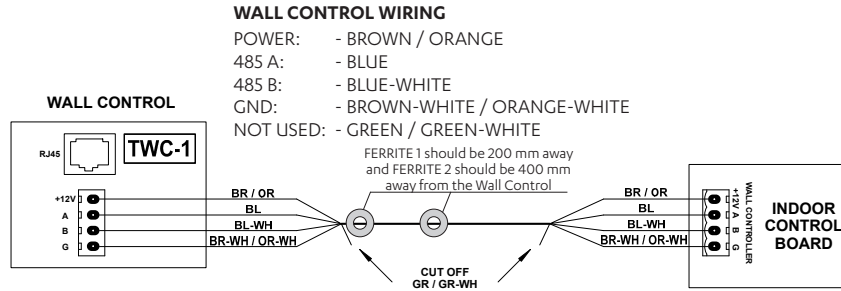

14.03. LM-RS-2 Optional Sensor Wiring Connections

REMOTE SENSOR WIRING

PAIR 1: - BLUE / BLUE-WHITE
 PAIR 2: - ORANGE / ORANGE-WHITE
 PAIR 3: - GREEN / GREEN-WHITE
 PAIR 4: - BROWN / BROWN-WHITE

NOTE:

- PAIR 1 AND 2 USED FOR ILLUSTRATION PURPOSES ONLY.
- CUT OFF AND TERMINATE ANY UNUSED PAIRS TO ENSURE NO WIRING IS LEFT EXPOSED.

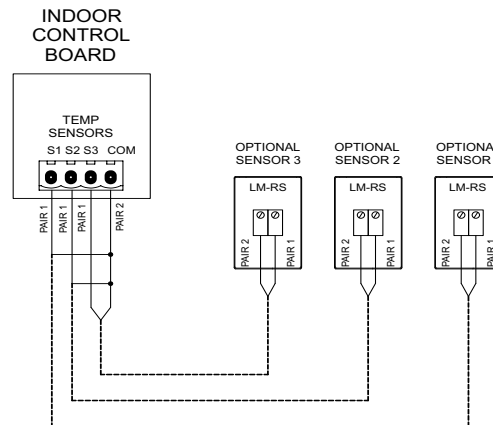

14.04. AERSS Optional Duct Sensor Wiring Connections

REMOTE SENSOR WIRING

PAIR 1: - BLUE / BLUE-WHITE
 PAIR 2: - ORANGE / ORANGE-WHITE
 PAIR 3: - GREEN / GREEN-WHITE
 PAIR 4: - BROWN / BROWN-WHITE

NOTE:

- PAIR 1 AND 2 USED FOR ILLUSTRATION PURPOSES ONLY.
- CUT OFF AND TERMINATE ANY UNUSED PAIRS TO ENSURE NO WIRING IS LEFT EXPOSED.

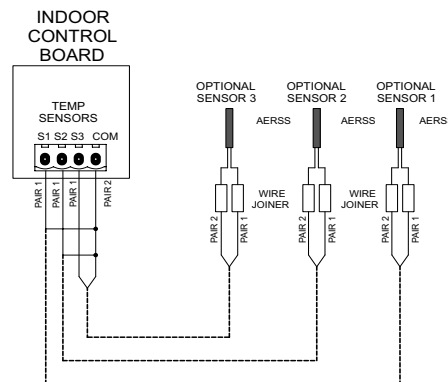

14.05. Demand Response Management (Outdoor Board)

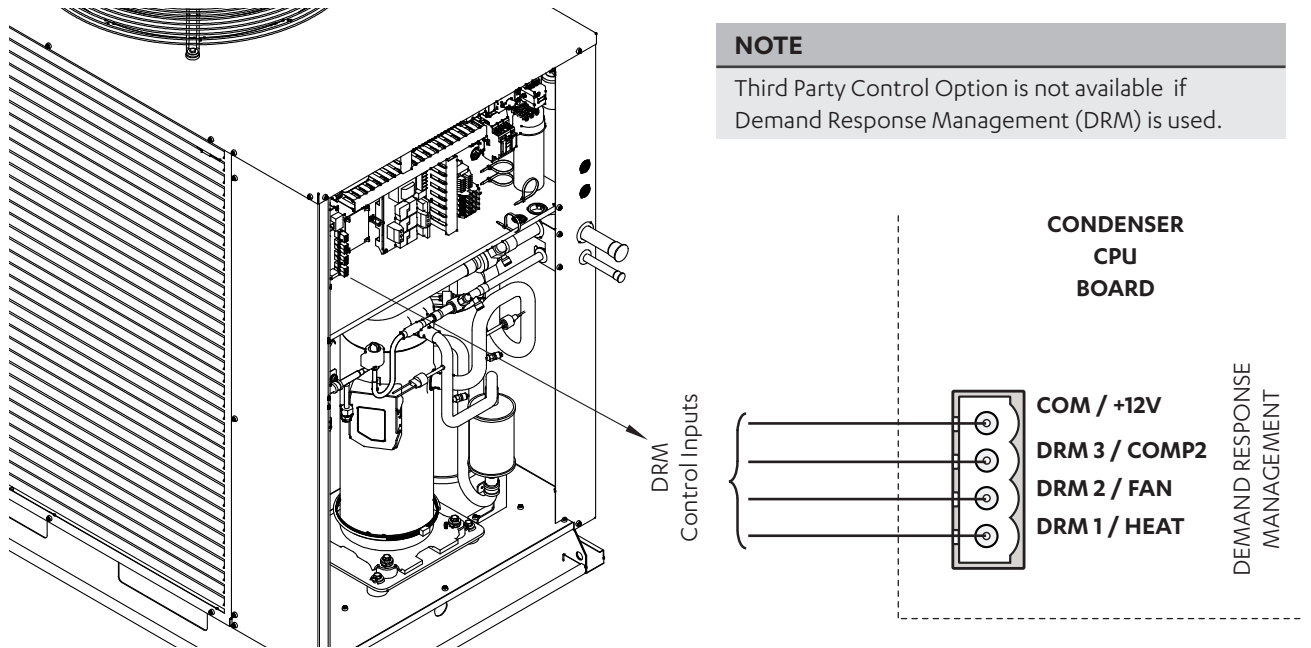

1. Route DRM input cables into the Unit (as per previous wiring installation procedure).
2. Connect cables into terminals (as shown above and as per wiring diagram provided with the unit).

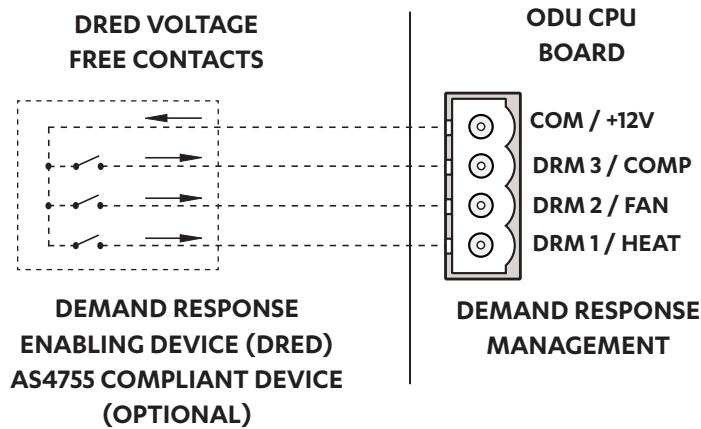

DEMAND RESPONSE ENABLING DEVICE CIRCUIT DIAGRAM

DEMAND MANAGEMENT MODE	DESCRIPTION OF MODE ALLOWABLE RANGE (%)	OPERATING MODE
DRM1	Compressor Off Mode	Compressor ONLY will cycle OFF and remain off for the entire Demand Response event. All other functions will operate as normal (i.e. Indoor Fan)
DRM2	Maximum 50% power use mode with 0 to < 50% allowable power use range	Compressor 0 to < 50% operation range for the total Demand Response event.
DRM3	Maximum 75% power use mode with 0 to < 75% allowable power use range	Compressor 0 to < 75% operation range for the total Demand Response event.

15. Configuring and Commissioning Setup

15.01. Menu and Navigation

diS (Display)	Display system's status and settings	
SEr (Service)	Service use only	
SEt (Settings)	cnFg	02.00 = Family*
		02.33 = Capacity*
	CtrS	Ct. 0 = 3rd Party
		Ct. 1 = Wall Control (default)
		Ct. 2 = Basic BMS
		Ct. 3 = Wall Control + Basic BMS
		Ct. 4 = Advanced BMS
	iduS	FP1 = IDU Fan Low PWM setting
		FP2 = IDU Fan Med PWM setting
		FP3 = IDU Fan High PWM setting
		Fr1 = IDU Fan Low RPM setting
		Fr2 = IDU Fan Med RPM setting
		Fr3 = IDU Fan High RPM setting
		FPd = IDU Fan Defrost PWM setting
		FPc = IDU Reduced Airflow PWM setting
		FiL = IDU Fan Filter Hours setting
		Econ = IDU Econ 0-10V Output setting
		FnSE = Indoor Fan Setting
		HtSt = HotStart On/Off
	SoFt	no = Soft Start not enabled (default)
		YES = Soft Start enabled
	run	no = Indoor Fan and Compressor (default)
		YES = Compressor only
	odFs	Hi = High Start-up Speed (default)
		Lo = Low Start-up Speed

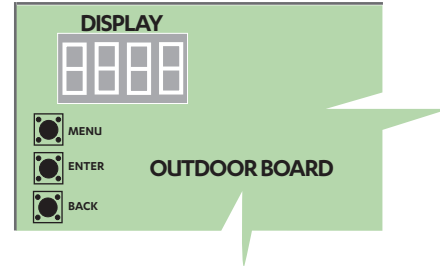

MENU

Scroll through the items at the same menu level. Increment the value being set.

ENTER

Go into the selected menu. Lock in selected value.

BACK

Go back to the parent menu. Press and hold to go back to main menu

* Family and Capacity are the representative values only and may vary depend on the model purchased as seen below table. **Do not change setting.**

Model	CRV290T	CRV330T
Family	Capacity (kW)	
02	29	33

15.02. Configuring Compressor and Capacity(cnFg)

Configure the compressor type and capacity. The unit is factory configured. **Do not change this setting.**

15.03. Configuring Control Source (CtrS)

This commissioning is applicable for BMS and other Wall Control. Configurable settings are as follows:

Third Party Control

The unit can be controlled by a non-ActronAir wall control. To do this, **CtrS** on the Outdoor Board has to be set to **Ct. 0**. For connection details, see the wiring diagram supplied with the outdoor unit.

Wall Control

ActronAir offers NEO and LC7-2, wall controls that can control the available features and maximise the function and operation of the air conditioner. To do this, CtrS on the Outdoor Board must be set to **Ct. 1**.

Basic BMS

The unit can be connected to a network through a BMS card (ICUNO-MOD). This allows the unit to be operated in the same way the as the NEO and LC7-2 does. To do this, **CtrS** on the Outdoor Board must be set to **Ct. 2**.

Wall Control + Basic BMS

The unit can be connected to a network (Basic BMS) and at the same time be controlled using the NEO or LC7-2 controller. Priority will be given to the most recent command. To do this, **CtrS** on the Outdoor Board must be set to **Ct. 3**.

Advanced BMS

The unit can be connected for system that requires customised functions not included in the existing software or logic in the Outdoor Board but still retaining the safety logic. To do this, **CtrS** on the Outdoor Board must be set to **Ct. 4**.

15.04. Configuring Indoor Fan Setting (iduS)

The fan settings may be configured using three options: the Condenser CPU Board, NEO, LC7-2 Wall Control and Third Party Control.

15.04.01. Indoor Fan Speed Commissioning

The Variable Capacity Commercial indoor fan operation is supplied as a single speed system, with speed settings model dependent. This speed is adjustable via outdoor board and the NEO or LC7-2 wall control (when connected). Refer to the fan curve and the fan table section of each models fan speed setting.

When the NEO or LC7-2 wall control is connected, the option of a 3-speed indoor fan is available to be programmed. The default speed settings for each of the three speeds (High, Medium and Low) are also shown in the table below. See Option 2: via Outdoor Board. For more details see Option 1: via Wall Control (NEO or LC7-2).

NOTE

ActronAir do not recommend adjusting the RPM limit. Before making any changes, please contact ActronAir Technical Support on 1800 119 229.

Option 1: via LC7-2 Wall Control

Summary :

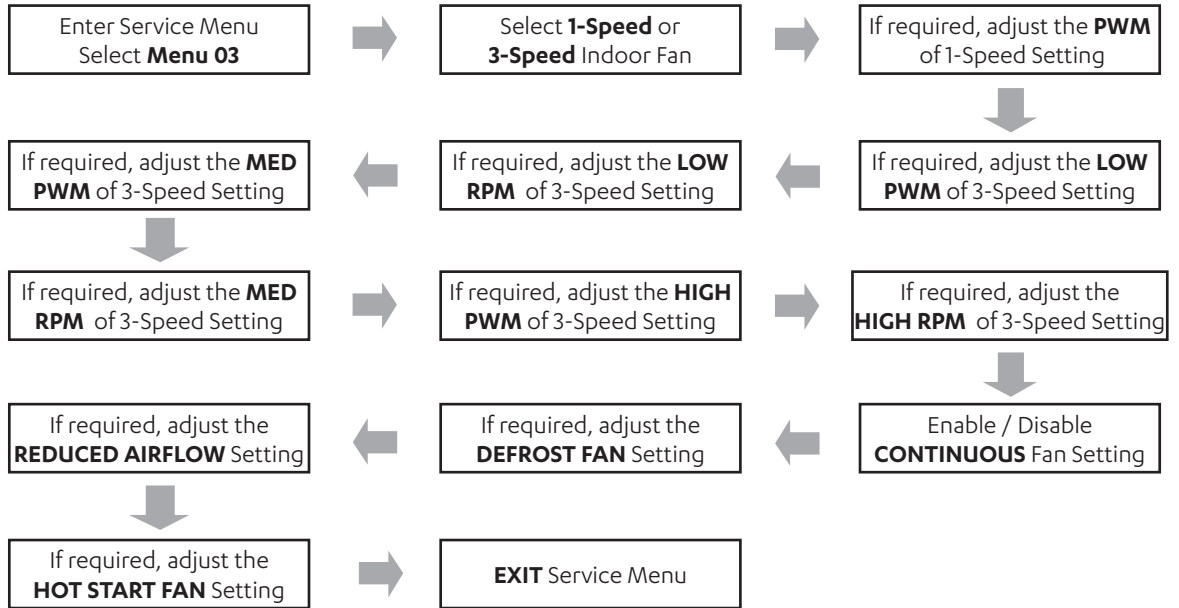

Procedure:

1. Press and hold the **REPEAT** and the **TIMER** buttons for 3 seconds then release to enter Service Menu.

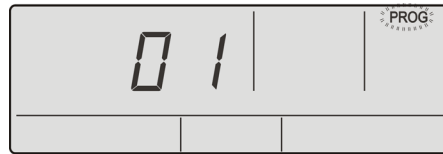

2. Press the  button to scroll through to Service Menu **03**.

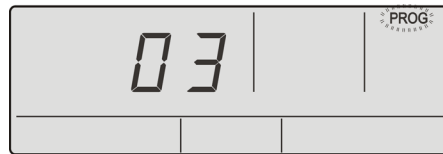

3. Press the **PROG** button to enter Service Menu **03**. Display will show the indoor fan speed selection.

NOTES





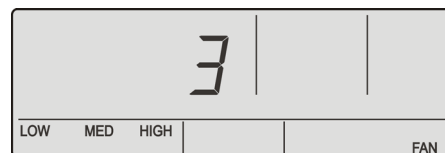

- 1 Speed indicated with number **1** and **MED** being illuminated.
- 3 Speed indicated with number **3** and **LOW**, **MED** and **HIGH** being illuminated.



1- Speed Indoor Fan DEFAULT







3- Speed Indoor Fan

- Press the   or  buttons to select 1 or 3-Speed indoor fan setting. Then press the **PROG** button to accept the selection.
- Display will show the current **PWM** (speed) setting. Also displayed are **MED, FAN** and the **1** to signify that you are about to change the fan speed of 1-speed fan setting. Press the   or  buttons to adjust the single speed indoor fan PWM. Then press the **PROG** button to accept.

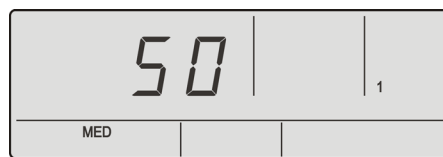
NOTES

It is not possible to skip this step even if 3-speed fan setting was selected. Either adjust the PWM or accept the default setting.





- Display shows **LOW, MED, HIGH, 3** and **FAN**. With **LOW** blinking to signify current **LOW PWM** settings for 3-speed fan. Press the   or  buttons to adjust the PWM setting. Then press the **PROG** button to accept.

NOTE

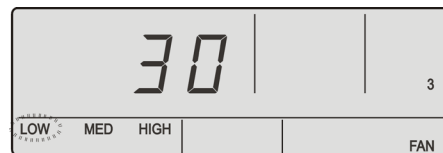
Default setting and adjustable range may vary depending on indoor models.



- Next display will show the RPM setting for **LOW SPEED**. Press the   or  buttons to adjust the RPM setting. Then press the **PROG** button to accept.

NOTES

- The RPM numbers displayed should be multiplied by 10 to get the actual RPM setting. Example here is $110 \times 10 = 1100$ RPM.
- ActronAir do not recommend adjusting the RPM limit.
- Before making any changes, please contact ActronAir Technical Support on 1800 119 229.

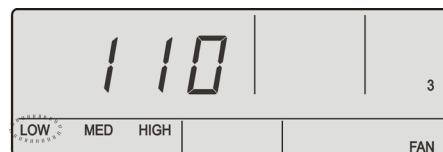

- Repeat Steps 6-7 to set **MED** and then **HIGH** PWM and RPM limit settings.
- Press **EXIT** button twice to leave the service menu.

Option 2: via Outdoor Board

The outdoor PCB has a 7 segment display, with 3 adjacent buttons, used for commissioning the indoor fan.

MENU → SEt → iduS →	PWM / RPM		SPEED SETTING	
	EVA290T	EVA330T	3 - SPEED	1 - SPEED
FP1	38	47	Low PWM	-
FP2	52	67	Med PWM	Med PWM
FP3	70	92	High PWM	-
Fr1	1200	1400	Low RPM	-
Fr2	1500	1750	Med RPM	Med RPM
Fr3	1800	2100	High RPM	-

Procedure:

1. Using the **MENU** and the **ENTER** buttons, navigate to **SEt** (Settings) → **iduS** (Indoor Settings).
2. If required, adjust and set **FP1** (Low PWM), **FP2** (Medium PWM) and **FP3** (High PWM).
3. If required, adjust and set **Fr1** (Low RPM Limit), **Fr2** (Medium RPM Limit) and **Fr3** (High RPM Limit).

NOTE

FP1 (Low PWM), **FP2** (Medium PWM), **FP3** (High PWM) are adjustable settings within PWM high and low range limits. Refer to Section 15 for more details.

Option 3: Third Party Control

(0-10V Fan)

1. On the Outdoor Board, set Control Source to Third Party. Using the **MENU** and the **ENTER** buttons, navigate to **SEt** (Settings) → **CtrS** (Control Source).
2. Use the **MENU** button to navigate to **0** to select Third Party Control as the control source. Press the **ENTER** button to save the setting.
3. On the Indoor Board, set the first dip switch to **ON** and also ensure dip switch 2 in **ON**.



4. Indoor Fan operation is now operational via 0-10V Third Party Control. For airflow and static pressure, see the fan curve and the fan table section for reference. Adjustable airflow range will vary from model to model.

(Fixed Speed)

1. On the Outdoor Board, set Control Source to Third Party. Using the **MENU** and the **ENTER** buttons, navigate to **SEt** (Settings) → **CtrS** (Control Source).
2. Use the **MENU** button to navigate to **0** to select Third Party Control as the control source. Press the **ENTER** button to save the setting.

NOTES

Adjustable airflow range will vary from model to model.
Medium Speed is the speed setting for 1-speed Fan.

- If medium speed setting (1-speed fan setting) is required to be changed, using the **MENU** and the **ENTER** buttons, navigate to **SEt** (Settings) → **iduS** (Indoor Settings) → **FP2** and **Fr2**.
- On the Indoor Board, ensure that all dip switches are set as per below image.

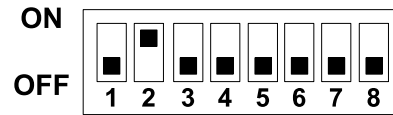

- Indoor Fan operation is now operational via Third Party Control (1-speed).

15.04.02. Defrost Fan Setting

This feature allows the installer to set the indoor fan speed (PWM) during defrost mode. By default, this is set to **0** PWM (Fan Off) to avoid cold air draft. However, in some applications, continuous air circulation may be required even when the system went to defrost cycle.

The Defrost Indoor fan speed (PWM) is can be set through the LC7-2 wall control or Outdoor PCB. Procedures are shown below:

Option 1: LC7-2 Wall Control

- Press and hold the **REPEAT** and the **TIMER** buttons for 3 seconds then release to enter Service Menu. The display will show the Service Menu **01**.
- Press the or buttons to scroll to Service Menu **03**. Press the **PROG** button to enter the Service Menu **03**.
- Press the **PROG** button 9 x times to enter the Defrost Fan Settings.



- Press the or buttons to select the desired indoor fan PWM then press the **PROG** button to accept. The available range is from 10 to 100. OFF means that the indoor fan is OFF during the defrost cycle. The sample screen below shows the indoor fan to 20.

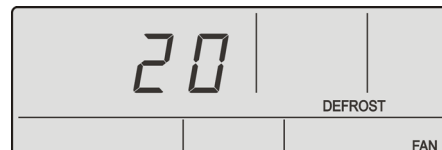

- Press the **EXIT** button twice to go back to the original status display.

Option 2: Outdoor Unit CPU Board



- Using the **MENU** and the **ENTER** buttons, navigate to **SEt** (Settings) → **iduS** (Indoor Settings) → **FPd** (Defrost PWM)
- Keep pressing the **MENU** button to select the desired indoor fan speed PWM is shown. By default, the indoor fan PWM is set to **0** and it is adjustable from **0** to **100**.
Note: **0** means the indoor fan is off during the defrost cycle.
- Press the **ENTER** button to confirm the PWM settings.
- Press the **BACK** button three times to go back to the original status display.

15.04.03. Reduced Airflow



This feature allows the system to run at lower airflow down to 20% (below system normal application range) when the compressor is not active (cycle off). This feature is useful to reduce the indoor fan power consumption during system operation but maintain the essential air circulation in the room. Note that if Continuous Fan is enabled, it takes precedent over the Reduced Airflow.

The available airflow range of reduced airflow is presented on the fan table Reduced Airflow (Compressor Off) on the next pages. By default, this option is enabled and set to **20** PWM. To turn OFF or change the PWM value:

Option 1: LC7-2 Wall Control

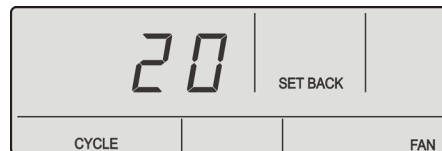
1. Press and hold the **REPEAT** and the **TIMER** buttons for 3 sec then release to enter Service Menu. The display will show the Service Menu **01**.
2. Press the  or  buttons to scroll to Service Menu **03**. Press the **PROG** button to enter the Service Menu **03**.
3. Press the **PROG** button 10x times to enter the Reduced Airflow Settings.



4. Press the  or  buttons to select the desired indoor fan PWM then press the **PROG** button to accept. The available range is from **20** to **100**. OFF means that this function is disabled. The sample screen below shows the indoor fan is set to 30 PWM.

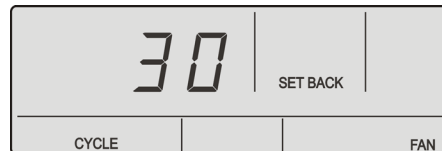

5. Press the **EXIT** button once to go back to the original status display.

Option 2: Outdoor Unit CPU Board



1. Using the **MENU** and the **ENTER** buttons, navigate to **Set** (Settings) → **iduS** (Indoor Settings) → **FPC** (Reduced PWM)
2. Keep pressing the **MENU** button to select the desired indoor fan speed PWM is shown. By default, the indoor fan PWM is set to **20** and it is adjustable from **20-100**.
Note: **0** means the Reduce Airflow Mode is disabled.
3. Press the **ENTER** button to confirm the PWM settings.
4. Press the **BACK** button three times to go back to the original status display.

15.04.04. Hot Start (Draft Reduction)

Hot Start is a feature only applicable in the heating cycle, that delays the indoor fans start-up. This allows the indoor coil to heat up before the indoor fan starts so an initial cold draft is prevented. When Hot Start is disabled the compressor and fan will start at approximately the same time.

LC7-2 Wall Control

1. Press and hold the **REPEAT** and **TIMER** buttons for 3 seconds then release to enter Service Menu. The display will show Service Menu **01**.

2. Press the  or  buttons to scroll to Service Menu **03**. Press the **PROG** button to enter the Service Menu **03**.
3. Press the **PROG** button 11 x times to enter the Hot Start Settings.

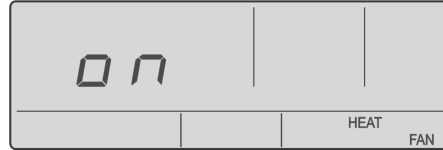

4. Press the  or  buttons to enable/disable the hot start operation.

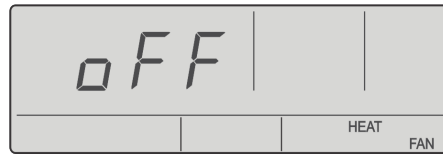

5. Press the **PROG** button to accept the Hot Start setting.
6. Press the **EXIT** button once to return to the Main Screen.

15.04.05. Air Filter Hours

This feature allows the installer to change the alarm time of Filter Notification. By default, the time before the filter alarm notification will appear is set to **200** hours. This is adjustable from **0** to **990** hrs.

Outdoor Unit CPU Board

1. Using the **MENU** and the **ENTER** buttons, navigate to **Set** (Settings) → **idus** (Indoor Settings) → **FiL** (Filter)
2. Keep pressing the **MENU** button to select the desired filter notification alarm time is shown. By default, alarm time is set to **200** hrs and is adjustable from **0** to **9900**

Note: **0** means the Filter Alarm is disabled

3. Press **ENTER** button to confirm the alarm time settings.
4. Press the **BACK** button twice to go back to the original status display.



NOTE

Setting up “Air Filter Hours” is only available through Outdoor Unit CPU Board.

15.04.06. Outside Air Damper

This feature allows to set the optional outside air damper opening. The available output signal is from **0** to **10V**.

Option 1: LC7-2 Wall Control

1. Press and hold the **REPEAT** and the **TIMER** buttons for 3 sec then release to enter Service Menu. The display will show the Service Menu **01**.
2. Press the  or  buttons to scroll to Service Menu **10**. Press the **PROG** button to enter the Service Menu **10**.
3. Press the **PROG** button enter economy damper menu.

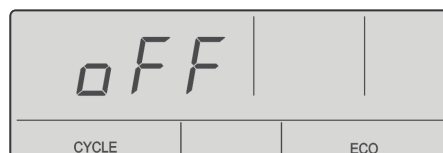

- Press the  or  buttons to enable economy damper, then press **PROG** to accept.

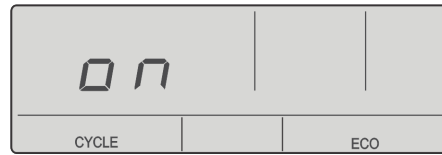

- Press the **PROG** button enter economy damper setting.

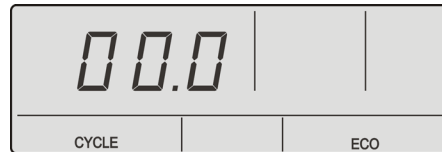

- Press the  or  buttons to adjust the voltage output in 0.1V increments (**0** to **10V**), then press **PROG** to accept. Sample below shows 3.0V output.

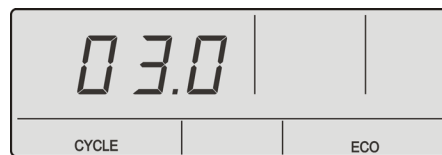

- Press the **EXIT** button once to go back to the original status display.



Option 2: Outdoor Unit CPU Board

- Using the **MENU** and the **ENTER** buttons, navigate to **Set** (Settings) → **idus** (Indoor Settings) → **Econ(0 to 10V Output)**
- Keep pressing the **MENU** button to select the desired opening (in voltage). By default, this is set to **0** (damper closed). Adjustable setting is from **0** to **10V**. (Note that in LED 7 segment display, 10.0V will show **100**.)
- Press **ENTER** to confirm the desired damper voltage. Press **BACK** button to leave the Menu.
- Press the **BACK** button three times to go back to the original status display.

15.04.07. Fan Continuous ON/OFF

This feature allows the user to access Continuous Fan Operation. Disabling this will hide the function from the wall control. By default, this function is enabled. To disable, follow the instruction below.

LC7-2 Wall Control

- Press and hold the **REPEAT** and the **TIMER** buttons for 3 sec then release to enter Service Menu. The display will show the Service Menu **01**.
- Press the  or  buttons to scroll to Service Menu **03**. Press the **PROG** button to enter the Service Menu **03**.
- Press the **PROG** button 7 x times to enter the Fan Continuous Settings.

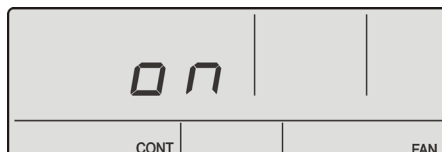

4. Press the  or  buttons to select OFF. Then press the **PROG** button to accept.

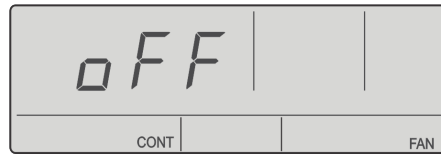

5. Press the **BACK** button twice to go back to the original status display.

NOTE

Setting up "Fan Continuous ON/OFF" is only available through LC7-2 Control.

15.04.08. Compressor Soft Start Option

If an ActronAir compressor soft starter (sold separately) will be installed, it is necessary to enable this in OD Board Menu. However, if the soft starter is already pre-installed with the unit ("-Z Option"), no set up is necessary.

Procedure:

1. Using the **MENU** and the **ENTER** buttons, navigate to **Set** (Settings) → **Soft** (Soft Start Settings).
2. If required, press **MENU** to navigate to **YES**. By default, this is set to **no**.

15.04.09. Run and Fault Indication Output

Run Output is configurable to indicate that the unit is running. There are two configurations in which this can be set

- Either the compressor or the Indoor Fan only is running
- Only Compressor is running.

By default, this is set to **no**, where indicator will turn on when either on ID Fan Only Operation mode or Compressor is running. To set up to compressor run indication only, in OD Board Menu follow below steps.

Procedure:

1. Using the **MENU** and the **ENTER** buttons, navigate to **Set** (Settings) → **run** (Unit Operation Indicator Settings).
2. If required, press **MENU** to navigate to **YES**.

16. Optional Output/Input Relay

16.01. Filter Indication Relay Output (Indoor Board)

Allows for optional connection for Filter Indication Relay (10A/240V). Option to use either normally open or normally close relay.

NOTE

To reset the alarm notification via Outdoor Board (no LC7-2 connected), set the time again to clear/reset the filter alarm output.

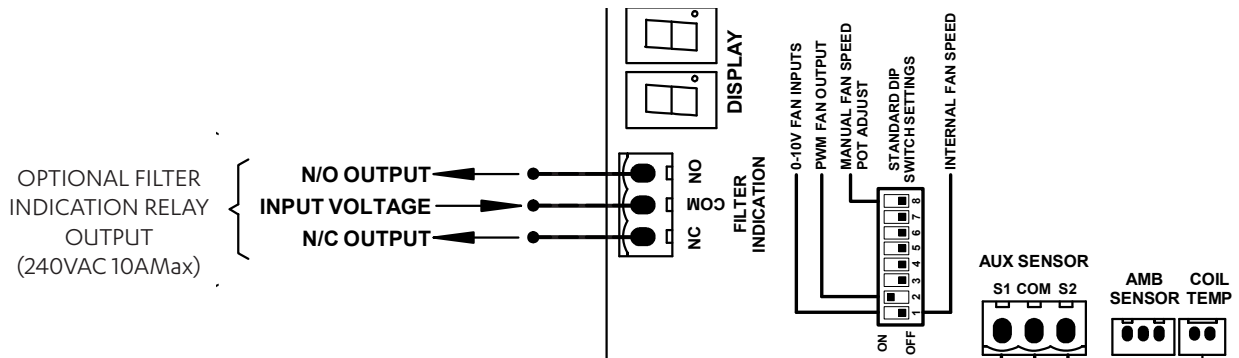

16.02. Fan Run Indication Output (Indoor Board)

Allows for optional Fan Run Indication (12VDC)

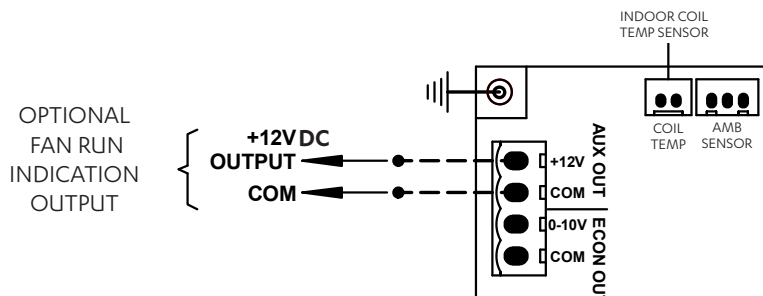

16.03. Optional Outside Air Damper Control Output (Indoor Board)

This feature allows to set the optional outside air damper opening (0-10V). To set-up, see 14.04.06 Outside Air Damper Section.

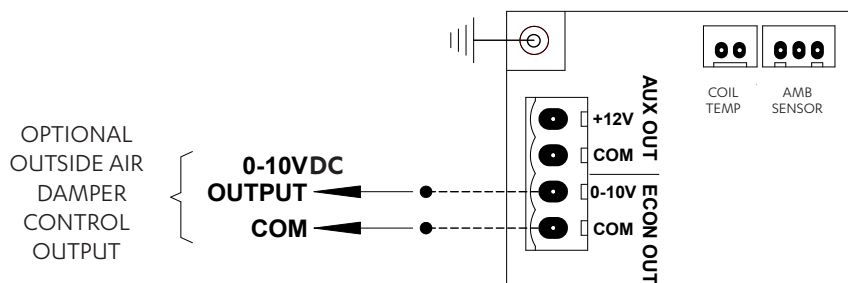

17. Third Party Control Input (Indoor Board and/or Outdoor Board)

This option allows Fan, Compressor and Reversing Valve to be controlled by a Third Party Control. There are two ways on how the Indoor Fan may be controlled, using 0-10V Analogue Input or Fixed Indoor Fan Speed.

NOTE

- Demand Response Management (DRM) is not available if Third Party Control Option is used.
- Make sure control source has been configured for Third Party Control (Refer to section 14.03).

17.01. 0-10V Analogue Input for Compressor and Indoor Fan

Indoor Fan Connection (Indoor Board)

On the Indoor Board, set the first dip switch to **ON**.

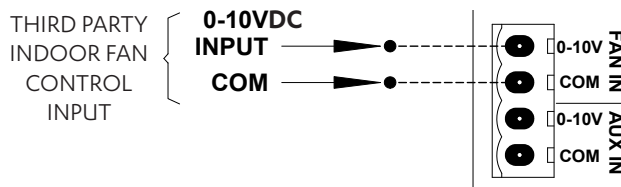

Input (DC)	Output	Fan Status
0.0V to 0.99 V	0%	Off
1.0V to 1.49 V	0 or 20%	Off or On
1.5V to 9.5 V	20% to 100%	On
9.5V to 10 V	100%	On

Compressor and Reversing Valve Connection (Outdoor Board)

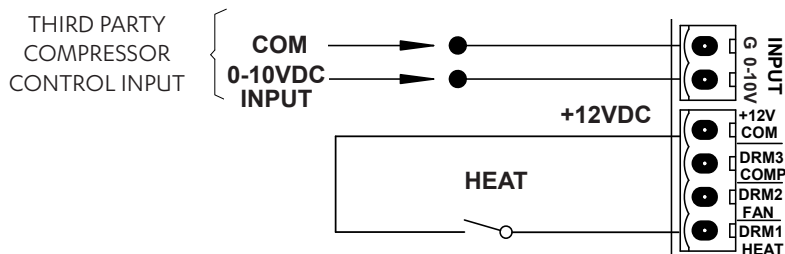

Input (DC)	Output	Compressor Status
0 - 0.99 V	0%	Off
1 - 1.49 V	0 or 20%	Off/On (hysteresis)
1.5 - 9.5 V	20% to 100%	On
9.5 - 10 V	100%	On

NOTES

- As the compressor turns ON and the Indoor fan signal is not available then indoor fan will start to run on medium PWM speed.
- If the compressor turns ON, during reduced fan operation, the controller will increase the fan speed to the "low PWM fan limit" if it is running less than the low PWM Limits .
- Indoor fan low and high PWM limits depends upon the model. Refer to Section 17 for more details.
- The Voltage can be linearly interpolated using the above table to determine the desired PWM or unit output.

17.02. 0-10V Analogue Input for Compressor with Fixed Indoor Fan Speed

This feature allows for the Indoor Fan to be controlled externally (ON/OFF only).

Fan, Compressor and Reversing Valve Connection (Outdoor Board)

On the indoor board ensure dip switch ONE is **OFF**.

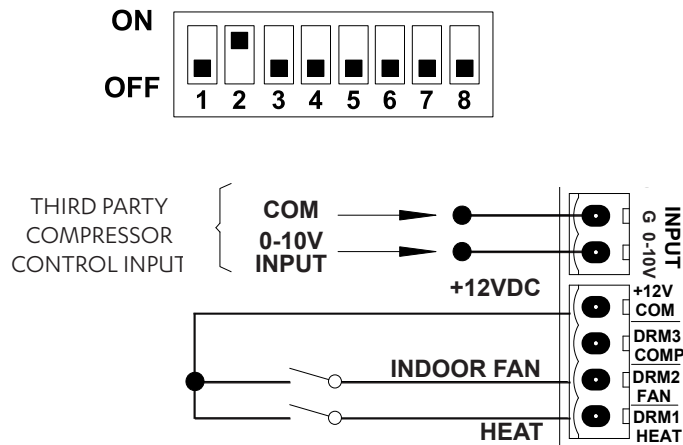

NOTES

- As the compressor turns ON and the Indoor fan signal is not available then indoor fan will start to run on medium PWM speed.
- Indoor fan operation when fan signal is available:
 - Compressor ON : Indoor fan will run on medium speed.
 - Compressor OFF : Indoor fan will run on reduce airflow operation.

17.03. Analogue Input for Fixed Compressor with Fixed Indoor Fan Speed

This feature allows for both Compressor and Indoor Fan to be controlled externally (ON/OFF only).

Fan, Compressor and Reversing Valve Connection (Outdoor Board)

On the indoor board ensure dip switch ONE is **OFF**.

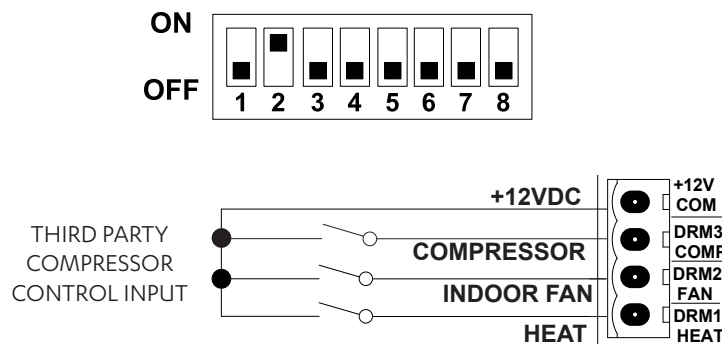

NOTES

- As the compressor turns ON and the Indoor fan signal is not available then indoor fan will start to run on medium PWM speed.
- Indoor fan operation when fan signal is available:
 - Compressor ON : Indoor fan will run on medium speed.
 - Compressor OFF : Indoor fan will run on reduce airflow operation.

17.04. 0-10V Analogue Input for Indoor Fan with Fixed Speed Compressor

This feature allows for the compressor to be controlled externally (ON/OFF only).

Indoor Fan Connection (Indoor Board)

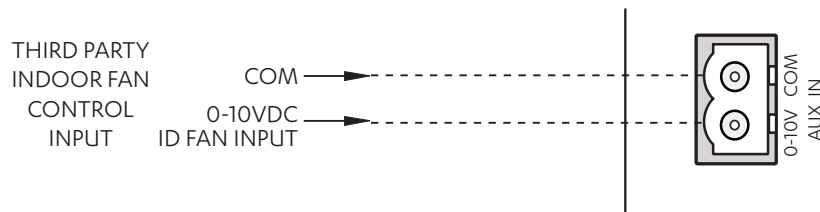

Input (DC)	Output	Fan Status
0.0 V to 0.99 V	0%	Off
1.0 V to 1.49 V	0 or 20%	Off or On
1.5 V to 9.5 V	20% to 100%	On
9.5 V to 10 V	100%	On

Fan, Compressor and Reversing Valve Connection (Outdoor Board)

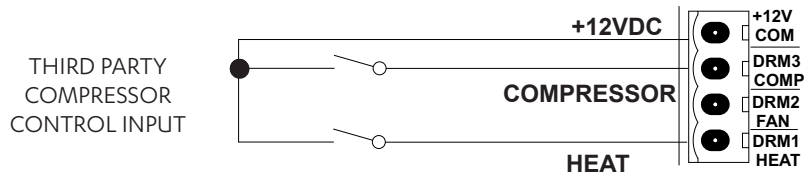

NOTES

- As the compressor turns ON and the Indoor fan signal is not available then indoor fan will start to run on medium PWM speed.
- If the compressor turn ON, during reduced fan operation, the controller will increase the fan speed to the "low PWM fan limit" if it is running less than the low PWM Limits.
- Indoor fan low and high PWM limits depends upon the model.
- The Voltage can be linearly interpolated using the above table to determine the desired PWM or unit output.
- Compressor turns on with 100% speed request.

17.05. Run and Fault Indication Output (Outdoor Board)

To activate, the unit must be wired as illustrated below. If required, a fault output connection terminal is also available to show any error/fault with the a/c system.

RUN/FAULT relay outputs (230VAC/5A MAX) connection

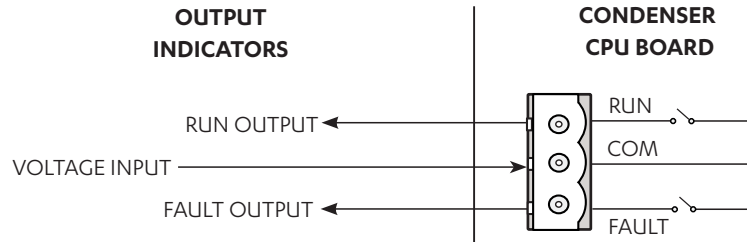

Run Output is configurable to indicate that the unit is running. There are two configurations in which this can be set:

- Either the compressor or the Indoor Fan only is running
- Only Compressor is running.

By default, this is set to turn on when either indoor fan or compressor is operating. To set up to compressor run indication only, in OD Board Menu follow below steps.

1. Using the **MENU** and the **ENTER** Buttons on the outdoor PCB, navigate to **Set** (Settings) → **run** (Unit Operation Indicator Settings).
2. If required, press **MENU** to navigate to **YES**.

17.06. Remote ON/OFF

To activate, the unit must be wired as illustrated below. This will enable unit to be turned ON and OFF from the Outdoor board.

NOTE

The system must be operating in Wall Controller only (control mode 1) or BMS + Wall Controller (control mode 3) for this function to work.

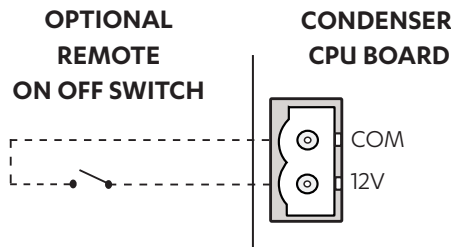

TURNING THE SYSTEM ON AND OFF BY REMOTE METHOD	
Turning the system On	Status 1: The system is Off and the remote switch/relay has been left in the open position. <ol style="list-style-type: none"> 1. Close remote switch/relay. 2. System will start in approximately 1 minute.
	Status 2: The system is Off and the remote switch/relay has been left in the closed position. <ol style="list-style-type: none"> 1. Open remote switch/relay for a minimum of 5 seconds. 2. Close remote switch/relay. 3. System will start in approximately 30 seconds.
Turning the system Off	Status 3: The system is On and the remote switch/relay has been left in the closed position. <ol style="list-style-type: none"> 1. Open remote switch/relay. 2. System will turn Off in approximately 1 minute.
	Status 4: The system is On and the remote switch/relay has been left in the open position. <ol style="list-style-type: none"> 1. Close remote switch/relay for a minimum of 5 seconds. 2. Open remote switch/relay. 3. System will turn Off in approximately 30 seconds.

18. Indoor Fan Table and Fan Curve

18.01. EVA290T

APPLICATION RANGE (COMPRESSOR ON)												
AIRFLOW (l/s)	EXTERNAL STATIC PRESSURE (Pa)											
	50		100		150		200		250		300	
	% PWM	W	% PWM	W	% PWM	W	% PWM	W	% PWM	W	% PWM	W
1200	33	333	38	452	42	557	46	668	50	787	54	905
1250	36	380	40	480	44	585	48	698	52	821	56	950
1300	38	408	42	508	47	642	51	760	54	859	60	1003
1350	40	434	45	559	49	670	53	794	57	919	62	1069
1400	43	484	47	587	51	700	55	826	60	981	66	1107
1450	45	507	50	639	54	763	58	886	63	1037	71	1171
1500	48	559	52	671	57	822	61	943	66	1091	74	1225
1550	51	612	55	730	59	848	64	1000	69	1156	78	1292
1600	53	641	58	785	62	903	67	1060	72	1205	83	1355
1650	56	694	61	838	66	989	70	1121	75	1276	88	1426
1700	59	750	64	890	69	1048	73	1181	79	1344	93	1500
1750	62	797	67	945	72	1106	77	1271	83	1414	99	1551
1800	66	877	70	1000	75	1163	79	1316	88	1497		

REDUCED AIRFLOW *(COMPRESSOR OFF)												
AIRFLOW (l/s)	EXTERNAL STATIC PRESSURE (Pa)											
	50		100		150		200		250		300	
	% PWM	W	% PWM	W	% PWM	W	% PWM	W	% PWM	W	% PWM	W
350											21	333
400											23	372
450											24	381
500											26	408
550											28	439
600											30	480
650											32	521
700											34	555
750											35	561
800											37	592
850											39	621
900											41	675
950											43	710
1000											45	744
1050											48	804
1100											50	831
1150											52	874

NOTES

* Reduced fan airflow is the airflow during compressor OFF operation (optional feature)

W = Indoor Fan Power, Watts

PWM = Pulse Width Modulation Setting, % PWM (Adjustable through the NEO, LC7-2 Control Interface or Outdoor Board).

Default Fan Speed Value at 100 Pa	
Speed	Default PWM
High PWM (%)	70 (adjustable)
Medium PWM (%)	52 (adjustable)
Low PWM (%)	38 (adjustable)

Indoor Fan PWM Limits	
High PWM (%)	99
Low PWM (%)	33

FAN CURVE

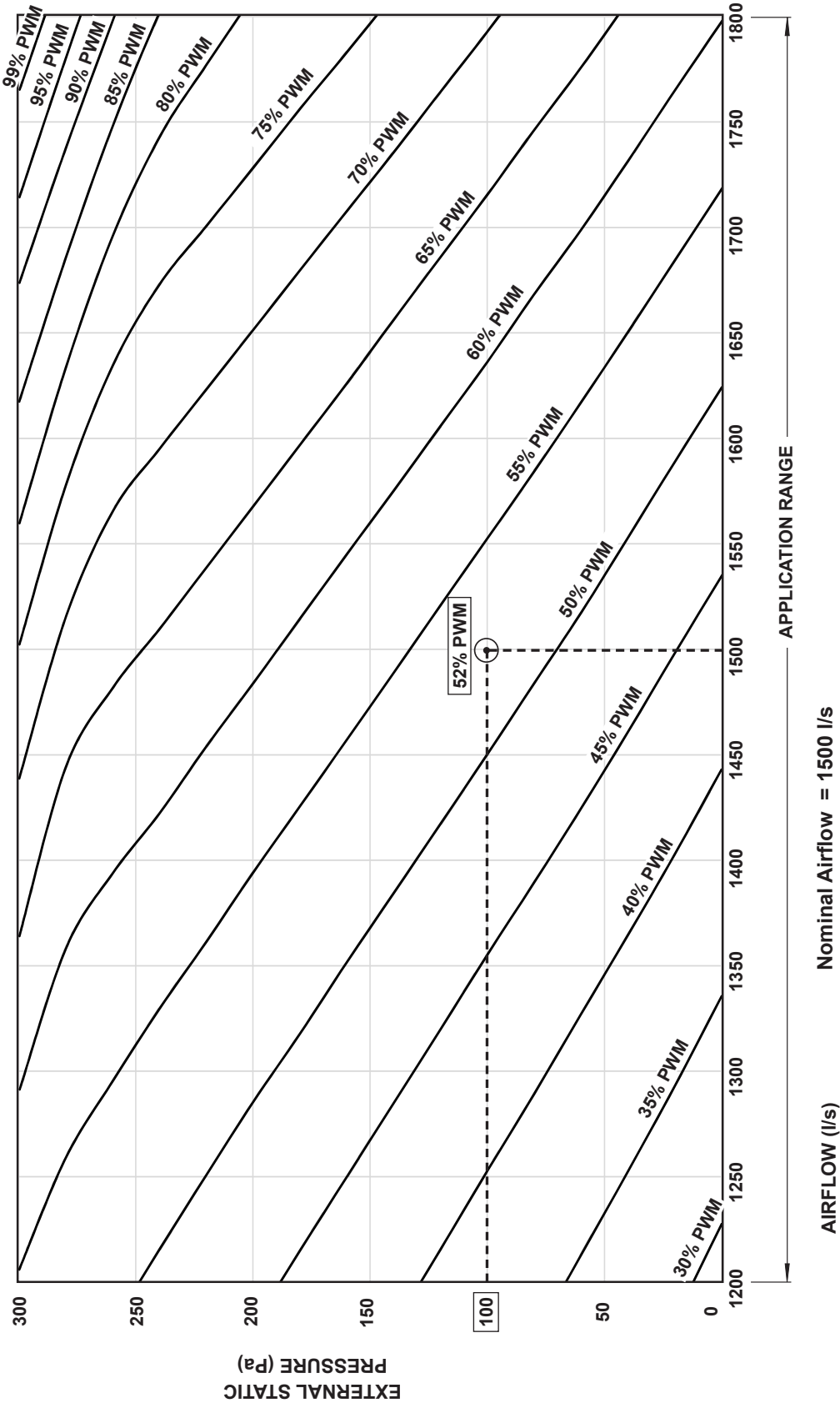

Notes:

- Performance Fan Curve shown is at Dry Coil Condition.
- Airflow should be reduced with respect to the moisture content in the air.
- All data provided does not include filters. Please review filter manufacturer for application.
- 2.5 m/s face velocity point will occur at 2150 l/s.

18.06. EVA330T

APPLICATION RANGE (COMPRESSOR ON)												
AIRFLOW (l/s)	EXTERNAL STATIC PRESSURE (Pa)											
	50		100		150		200		250		300	
	% PWM	W	% PWM	W	% PWM	W	% PWM	W	% PWM	W	% PWM	W
1400	42	463	47	589	51	707	54	835	59	961	71	1118
1450	45	509	49	630	53	755	58	896	62	1011	74	1172
1500	48	559	52	677	55	800	60	935	65	1075	78	1225
1550	50	601	54	725	59	853	63	992	68	1112	82	1288
1600	53	649	57	776	62	908	66	1045	70	1184	85	1354
1650	55	695	61	831	65	965	69	1104	74	1243	90	1419
1700	58	733	64	888	68	1026	72	1167	78	1316	95	1506
1750	62	803	67	947	71	1087	75	1235	83	1401	99	1564
1800	65	862	70	1006	74	1154	78	1308	88	1474	MOTOR / BLOWER LIMIT	
1850	69	926	73	1076	78	1228	82	1376	93	1557		
1900	72	988	77	1148	81	1305	86	1457	98	1639		
1950	75	1058	80	1223	85	1389	89	1533				
2000	79	1134	84	1305	89	1468	94	1624				
2050	83	1206	88	1387	92	1556	99	1721				
2100	87	1304	92	1474	96	1638						

REDUCED AIRFLOW *(COMPRESSOR OFF)												
AIRFLOW (l/s)	EXTERNAL STATIC PRESSURE (Pa)											
	50		100		150		200		250		300	
	% PWM	W	% PWM	W	% PWM	W	% PWM	W	% PWM	W	% PWM	W
350	MOTOR / BLOWER LIMIT									12	174	
400	MOTOR / BLOWER LIMIT									23	347	
450	MOTOR / BLOWER LIMIT									25	393	
500	MOTOR / BLOWER LIMIT									26	403	
550	MOTOR / BLOWER LIMIT									28	431	
600	MOTOR / BLOWER LIMIT									30	476	
650	MOTOR / BLOWER LIMIT									32	499	
700	MOTOR / BLOWER LIMIT									34	532	
750	MOTOR / BLOWER LIMIT									35	561	
800	MOTOR / BLOWER LIMIT									37	580	
850	20	176	24	257	27	323	31	418	35	524	39	615
900	21	183	25	263	29	352	33	453	37	561	42	665
950	23	209	27	291	31	383	35	486	38	568	44	714
1000	25	232	29	318	33	415	36	492	40	600	47	763
1050	27	259	31	345	34	420	38	524	43	669	50	804
1100	29	282	33	375	36	449	41	585	46	727	52	845
1150	31	308	35	402	39	503	43	618	48	764	55	887
1200	33	335	37	431	41	536	46	678	50	794	57	929
1250	35	361	39	457	44	594	48	708	52	832	60	969
1300	37	387	42	513	46	623	50	737	54	888	64	1024
1350	40	426	44	541	48	659	52	780	56	918	67	1065

NOTES

* Reduced fan airflow is the airflow during compressor OFF operation (optional feature)

W = Indoor Fan Power, Watts

PWM = Pulse Width Modulation Setting, % PWM (Adjustable through the NEO, LC7-2 Control Interface or Outdoor Board).

Default Fan Speed Value at 100 Pa	
Speed	Default PWM
High PWM (%)	92 (adjustable)
Medium PWM (%)	67 (adjustable)
Low PWM (%)	47 (adjustable)

Indoor Fan PWM Limits	
High PWM (%)	99
Low PWM (%)	42

FAN CURVE

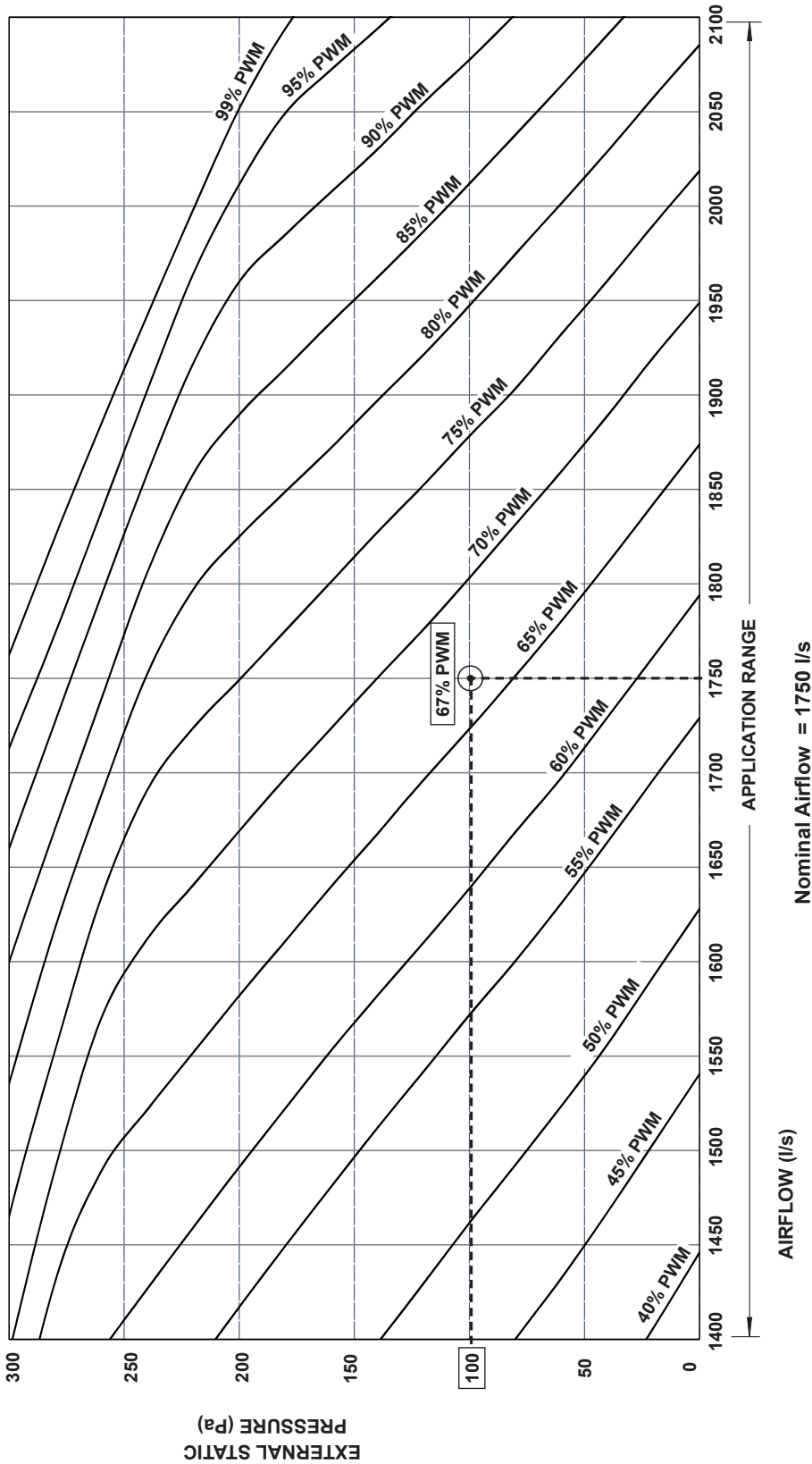

Nominal Airflow = 1750 l/s

Notes:

- 7. Performance Fan Curve shown is at Dry Coil Condition.
- 8. Airflow should be reduced with respect to the moisture content in the air.
- 9. All data provided does not include filters. Please review filter manufacturer for application.
- 10. 2.5 m/s face velocity point will occur at 2150 l/s.

19. Refrigerant Charging

- The units detailed on this guide are factory charged with R-410A refrigerant. Should there be need to add or remove refrigerant, it is recommended to follow the charging method explained below.
- Never allow R-410A refrigerant to vent into the atmosphere. It is an offence to release refrigerant in Australia. Always reclaim refrigerant using equipment and container dedicated for R-410A system use only.
- All work must be carried out in accordance with Australia and New Zealand refrigerant handling code of practice.
- Only qualified technicians are allowed to perform any work described in this guide and specifically work related to addition or removal of refrigerant.
- R-410A refrigerant must always be charged in liquid state.
- Only during the compressor running condition the system can be charged through the suction service port on the compressor suction line.
- Changes in refrigerant charge must be noted to a label that is fixed to the unit for future reference.

CAUTION

The system of this unit operates with POE oil that rapidly absorbs moisture. The maximum time any system can be opened to atmosphere is 15 minutes.

REFRIGERANT CHARGE DETAILS (R-410A)					
Model	Refrigerant Charge (g)	Pre-charged Length (m)	Additional Refrigerant per metre	Field Pipe Sizing (mm)	
				Liq.	Gas
CRV290T	9,600	5	165	5/8" (15.88)	1-1/8" (28.6)
CRV330T	11,300	5	165	5/8" (15.88)	1-1/8" (28.6)

Charging Method: Subcooling and Superheat

Parameters:

LLT = Liquid Line Temperature

SLT = Suction Line Temperature

SCT = Saturated Condensing Temperature

SST = Saturated Suction Temperature

Cooling and Heating Operation:

Adjust the refrigerant charge to obtain the correct superheat and subcooling for optimal performance as follows:

1. Ensure that air filters are fitted and total system airflow is achieved. (Air filters are not supplied with the unit, it is the responsibility of the installing contractor to provide and fit adequate return air and outside air filters).
2. Connect service gauges to the schrader valves.
3. Start the unit in cool mode ensuring that compressors are in 100% operation before taking service gauges reading. Allow the system to stabilise for next 15-30 minutes before recording.

Record the discharge pressure, suction pressure, liquid line temperature and suction line temperature for all of the refrigeration circuits:

Discharge Pressure = _____ kPa

Suction Pressure = _____ kPa

Liquid Line Temperature (**LLT**) = _____ °C

Suction Line Temperature (**SLT**) = _____ °C

NOTE

Accurate pressure and temperature measuring tools should be used to achieve satisfactory results.

See Diagram Below

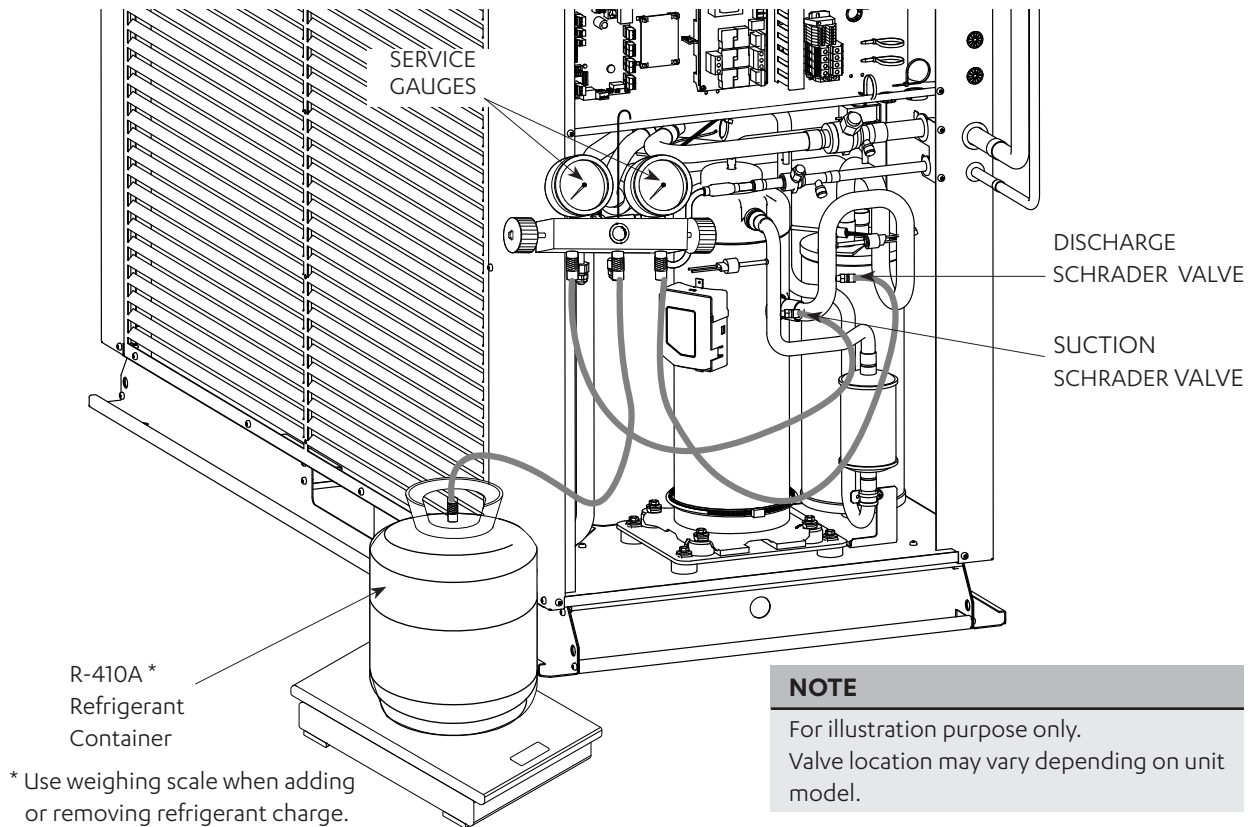

Checking for Subcooling:

1. From the R-410A Pressure/Temperature Chart record the corresponding Saturated Condensing Temperature (**SCT**) at the given discharge pressure.
2. Calculate the system subcooling using the formula below:

$$\text{Subcooling} = \text{SCT} - \text{LLT}$$

3. If subcooling is within the range (see charging table), there is no need to add/remove refrigerant.
 - If subcooling is lower than minimum, the system is undercharged, it is necessary to add refrigerant.
 - If subcooling is higher than maximum, the system is over charged . It is necessary to remove refrigerant.

Allow the systems to stabilise (15-30 mins) and repeat the step 1-3 until subcooling falls within the range specified in the Subcooling and Superheat Table .

Checking for Superheat:

Maintaining the correct superheat is important for ensuring the evaporator is achieving maximum capacity and avoiding excessive liquid refrigerant returning to the compressor.

1. From the R-410A Pressure/Temperature Chart record the corresponding Saturated Suction Temperature (**SST**) at the given suction pressure.
2. Calculate the system superheat using the formula below:

$$\text{Superheat} = \text{SLT} - \text{SST}$$

3. If superheat is within the range (see charging table below), there is no need to add/remove refrigerant.
 - If superheat is lower than minimum, it means that liquid refrigerant may be returning to compressor. It is necessary to remove refrigerant or check EEV settings.
 - If superheat is higher than maximum, it means that refrigeration capability of evaporator is not fully maximised. It is necessary to add refrigerant charge or check EEV settings.

Allow the systems to stabilise (15-30 mins) and repeat the step 1-3 until superheat falls within the range specified in the table below.

SUBCOOLING AND SUPERHEAT TABLE					
Models	Nominal Indoor Airflow (L/S)	Cooling		Heating	
		Subcooling	Superheat	Subcooling	Superheat
CRV290T	1500	7 ±1	3 ±1	12 ±1	2 ±1
CRV330T	1750	8 ±1	4 ±1	13 ±1	6 ±1

R-410A PRESSURE / TEMPERATURE CHART

Temp °C	Pressure KPa	Temp °C	Pressure KPa	Temp °C	Pressure KPa	Temp °C	Pressure KPa
-60	-34.4	-28	194.9	4	805.9	36	2090.7
-59	-30.7	-27	206.9	5	834.1	37	2145.5
-58	-26.8	-26	219.2	6	862.9	38	2201.3
-57	-22.8	-25	231.9	7	892.6	39	2258.2
-56	-18.6	-24	245.1	8	922.8	40	2316.1
-55	-14.2	-23	258.7	9	953.8	41	2375.1
-54	-9.6	-22	272.6	10	985.4	42	2435.1
-53	-4.8	-21	286.9	11	1017.8	43	2496.2
-52	0.8	-20	301.7	12	1050.9	44	2558.5
-51	5.3	-19	316.9	13	1084.7	45	2621.8
-50	10.7	-18	332.6	14	1119.2	46	2686.2
-49	16.3	-17	348.7	15	1154.6	47	2751.8
-48	22.2	-16	365.2	16	1190.7	48	2818.5
-47	28.2	-15	382.3	17	1227.5	49	2886.4
-46	34.0	-14	399.7	18	1265.2	50	2955.5
-45	40.9	-13	417.7	19	1303.6	51	3025.7
-44	47.8	-12	436.2	20	1342.9	52	3097.2
-43	54.8	-11	455.1	21	1382.9	53	3169.9
-42	62.1	-10	474.6	22	1423.9	54	3243.7
-41	69.6	-9	494.6	23	1465.7	55	3318.9
-40	77.4	-8	515.1	24	1508.3	56	3395.2
-39	85.5	-7	536.2	25	1551.8	57	3472.9
-38	93.9	-6	557.8	26	1596.2	58	3551.8
-37	102.5	-5	579.9	27	1641.4	59	3631.9
-36	111.5	-4	602.6	28	1687.6	60	3713.5
-35	120.8	-3	625.9	29	1734.6	61	3796.3
-34	130.4	-2	649.8	30	1782.6	62	3880.5
-33	140.3	-1	674.3	31	1831.6	63	3965.9
-32	150.5	0	699.4	32	1881.5	64	4052.8
-31	161.1	1	724.9	33	1932.3	65	4140.9
-30	171.9	2	751.3	34	1984.1	66	4230.6
-29	183.3	3	778.3	35	2036.9	67	4321.5

20. Maintenance

This section describes the procedures that must be performed as a part of normal maintenance PROG. Regular servicing of equipment by licensed technician is highly recommended. Regular servicing of your unit helps in maintaining its optimum performance and reliability. **The checklist and service periods provided on this manual are guides only, as some sites may require more frequent servicing.**

Always disconnect electrical power to the unit before performing these procedures. It is always a safe practice to observe all safety warnings and cautions when conducting maintenance tasks.

DANGER

Live Electrical Connections !

It may be necessary to work with live electrical components on certain maintenance tasks. Only licensed electricians and qualified technicians are allowed to perform these tasks.

Beware of Rotating Fan Blades !

Always make sure that all power supply, to the Outdoor Fans are turn-off and isolated.

Observe WH&S safety procedures, do not wear loose clothing and any jewellery when working near the fans.

Wear PPE whenever performing any maintenance procedures.

Observe all necessary procedures when working on a confined space.

WARNING

Hazardous Voltage !

Always make sure that all power supply, including remote controls, are disconnected before performing maintenance.

Observe proper LOCK-OUT/TAG-OUT (LOTO) procedures to ensure that power cannot be inadvertently energised. Failure to disconnect power before maintenance procedures can result in serious injury and/or death.

EC Motors are fitted with high power capacitors and can have dangerous residual voltages at motor terminals after power has been isolated. Wait at least 5 minutes after power isolation and test for any residual voltage before beginning service work.

Annual Maintenance Checklists

- Perform general maintenance inspections.
- Perform scheduled start-up checks.
- Leak test refrigerant circuits.
- Inspect contacts of all contactors and relays. Replace all worn contacts as required.
- Inspect, clean and tighten all electrical connections.
- Check fans for balanced operation. Make sure that there are no loose screws / bolts, no fan blades interference and no damage to the fans and guards.
- Inspect the air filters, clean or replace as required.
- Clean and repaint any corroded panel section.
- Ensure no blockage of airflow through variable speed drive.

Cleaning the Condenser Coils

Clean the coils at least once a year or more frequently if unit is located in a dusty and dirty environment, in order to maintain your system's proper operating performance. High discharge pressures are good indication that the coils need cleaning. When using detergent or solvents to clean the coils, follow the manufacturer's instructions to avoid potential damage to the coils and to the unit.

To clean the refrigerant coils, use a soft brush and water spray, such as garden hose or pressure washer with low pressure nozzle.

WARNING

Do Not Use High Alkaline Detergent!

When using detergent for coil cleaning, ensure that the alkaline level is no higher than 8.5, which can cause corrosion damage to the coils.

No Water into the Drive!

Ensure consideration is given to the possibility of water entering the electrical compartments during cleaning of the condenser coil.

Coil Cleaning Procedures

- Disconnect power to the unit.
- Remove the louvered panels from the unit to gain access to the air inlet side of the coils.
- Use a soft brush to remove loose dirt and debris from both sides of the coils.
- Straighten bent coil fins with fin comb.
- Prepare the detergent solutions according to the manufacturer's instructions.
- Spray solution at a 90° angle to the coils, keeping a minimum nozzle spray angle of 15°, with at least a 1800mm distance from the coils and 600 psi pressure.
- Spray leaving air side of the coils first then the air inlet side. Allow the solution to stand on the coils for five minutes.
- Rinse both sides of the coils with cool clean water.
- Inspect the coils, if they are still dirty, repeat the cleaning procedure.
- Clean and wipe dry the outer and inner sides of the unit, the refrigerating parts and other components.
- Ensure that the condensate drain lines are not blocked.
- Reinstall all unit panels, covers and guards.
- Restore electrical power to the unit.

21. Maintenance Frequency Checklist

ELECTRICAL											
Parts	Service Frequency					Detail of Service Check	Service Methods				
	1 Mth	3 Mth	6 Mth	1 Yr	2 Yrs			3 Yrs	4 Yrs	5 Yrs	
Printed Circuit Boards				✓						Visual Inspection	Tighten Terminals as necessary on printed circuit boards
Electrical Connections				✓						Check all electrical terminals, mains, communications, etc	Re-tighten if loose.

INDOOR UNIT											
Parts	Service Frequency					Detail of Service Check	Service Methods				
	1 Mth	3 Mth	6 Mth	1 Yr	2 Yrs			3 Yrs	4 Yrs	5 Yrs	
Casing/ Panels and Frames				✓						Visual check for damage, rust and dust accumulation.	For highly corrosive environment, wash panels quarterly with water and neutral detergent solution. Wax panels. Repair / re-paint where required.
Insulation				✓						Visual check for insulation conditions.	Repair / replace insulation material.
Fan				✓						Visual check for run out of balance and dust attached	Clean off dust as necessary to negate possibility of fan running out of balance
Motor				✓ Ω						Visual check on wiring. Insulation resistance check to be carried out annually	Measure insulation resistance to earth with insulation tester. Insulation resistance should be more than 1MΩ.
Heat Exchanger				✓						Check for clogging by dust. Check for leaks / damage.	Clean air inlet side as necessary. Straighten any bent fins using fins comb.
Drain Pan/ Condensation line				✓						Check for obstructions and free flow of water	Clean to eliminate obstructions/ sludge and check condition of pan. Pour water to ensure free flow.
Filter*	✓									Check for clogging by dust.	Clean Filter
Temperature Readings				✓						Measure air on and air off	Place temperature probe in return and supply air of unit.
Ducting				✓						Inspect duct works for air gaps.	Re-tape any loose ducts.

*1-3 month, subject to operating conditions and environment.

OUTDOOR UNIT											
Parts	Service Frequency					Detail of Service Check	Service Methods				
	1 Mth	3 Mth	6 Mth	1 Yr	2 Yrs			3 Yrs	4 Yrs	5 Yrs	
Casing / Panels and Frames				✓						Visual check for damage, rust and dust accumulation.	For highly corrosive environment, wash panels quarterly with water and neutral detergent solution. Wax panels. Repair / re-paint where required.
Insulation				✓						Visual check for insulation conditions.	Repair / replace insulation material.
Fan				✓						Visual check for run out of balance and dust attached	Clean off dust as necessary to negate possibility of fan running out of balance
Motor				✓ Ω						Visual check on wiring. Insulation resistance check to be carried out annually	Measure insulation resistance to earth with insulation tester. Insulation resistance should be more than 1MΩ.
Heat Exchanger				✓						Check for clogging by dust. Check for leaks / damage.	Clean air inlet side as necessary. Straighten any bent fins using fins comb.
Condensate Drain Line (if available)				✓						Check for obstructions and free flow of water	Clean to eliminate obstructions/ sludge and check condition of drain line. Pour water to ensure free flow.
Compressor				✓ Ω						Check for high / low pressure. Measure insulation resistance. Check compressor for abnormal noise/vibrations	Measure insulation resistance. Should be more than 1MΩ.
Refrigeration Operational Readings				✓						Make note of operational reading in test cool/heat	Check operating pressures, record superheat and subcooling values
Safety Devices				✓						Check calibration of safety devices such as HP and LP controls, sensors, etc	Check resistance of sensors, pressure cut in / cut out of pressure controls
Faults				✓						Check for any previous fault history on unit.	Investigate any causes for previous faults, reset fault history.
Outdoor Fan Speed Capacitor				✓						Check for any bulge on the capacitors & capacitance.	Make it electrically safe prior to measure the capacitor capacitance. Measured capacitance should be within the printed tolerances on the capacitor.

22. Start Up and Commissioning Report

INSTALLATION INFORMATION			
CUSTOMER	Name:	Tel. Number:	
	Address:		
INSTALLER	Name:	Tel. Number:	
	Address:		
Site Address:		Date Installed:	

Model:	Serial Number:
--------	----------------

CIRCUIT TEMPERATURE SETTINGS AND AMBIENT TEMPERATURE			
SYSTEM 1		SYSTEM 2	
Supply Air Temperature	°C	Supply Air Temperature	°C
Return Air Temperature	°C	Return Air Temperature	°C
Suction Temperature	°C	Suction Temperature	°C
Discharge Temperature	°C	Discharge Temperature	°C
Condenser Coil Temperature	°C	Condenser Coil Temperature	°C

Ambient Temperature	°C
---------------------	----

INDOOR FAN SETTINGS			
Indoor Fan Current	Amps	Outdoor Fan Current	Amps
Indoor Fan Airflow	l/s	Indoor Fan PWM	%
Set Static	Pa		

Check No Active Error Codes on the Unit	Checked:	<input type="checkbox"/>	Date Checked:	
---	----------	--------------------------	---------------	--

NOTES

Ensure to record operational settings on this table for future reference. Keep this manual in a safe place and readily available for service technicians.



©Copyright 2019 Actron Engineering Pty Limited ABN 34 002767240. ®Registered Trade Marks of Actron Engineering Pty Limited.
ActronAir is constantly seeking ways to improve the design of its products, therefore specifications are subject to change without notice.

Installation and Commissioning Guide - Split Ducted Variable Capacity Commercial Outdoor Unit
Doc. No.0525-066 Ver. 9 24xxxx