

Variable Capacity Commercial Package Ducted Units

Installation and Commissioning Guide



PACKAGE MODELS

UNDER/OVER
CONFIGURATION

PKV290T-T
PKV330T-T

SIDE BY SIDE
CONFIGURATION*

PKV290T-L/R
PKV330T-L/R

*Left Air Handling Option shown for illustration purposes only.
Left Air Handling Option.
Right Air Handling Option.

IMPORTANT NOTE:

Please read this manual carefully before installing or operating your air conditioning unit.



Table of Contents

01. Inspections.....	3
02. General Information	3
03. Safety Instructions	4
04. Installation Information.....	5
05. Wall Control Operation Manual Access	6
06. Components Overview	7
07. Package Unit Dimensions / Clearances	9
07.01. Package Model : PKV290T-T / PKV330T-T	9
07.02. Package Model : PKV290T-L/PKV330T-L	11
07.03. Package Model : PKV290T-R / PKV330T-R	13
08. Unit Lifting Procedure	15
09. Outdoor Unit Preparation	17
10. Condensate Drainage Instructions	19
11. Electrical Installation	20
12. Package Unit Electrical Connection.....	21
13. Maximum Cable Length	22
13.01. Wall Controller Options	22
13.02. Wiring Configuration 1 : Recommended	23
13.03. Wiring Configuration 2 : Alternate	24
14. Wiring Connections	25
14.01. LC7-2 Wall Control Wiring Connections	25
14.02. NEO Wall Control Wiring Connections	25
14.03. LM-RS-2 Optional Sensor Wiring Connections	26
14.04. AERSS Optional Duct Sensor Wiring Connections	26
15. Configuring and Commissioning Setup	27
15.01. Menu and Navigation	27
15.02. Configuring Compressor and Capacity (cnFg)	27
15.03. Configuring Control Source (CtrS)	27
15.04. Configuring Indoor Fan Setting (iduS)	28
16. Optional Output/Input Relay	36
16.01. Filter Indication Relay Output (CMI Board)	36
16.02. Fan Run Indication Output (CMI Board)	37
16.03. Optional Outside Air Damper Control Output (CMI Board)	37
16.04. Third Party Control Input (CMI Board and/or Outdoor)	37
16.05. Demand Response Management (Outdoor Board)	40
16.06. Run and Fault Indication Output (Outdoor Board)	41
16.07. Remote ON/OFF	41
17. Indoor Fan Table And Fan Curve	42
17.01. PKV290T-T	42
17.02. PKV330T-T	44
17.03. PKV290T-L/R	46
17.04. PKV330T-L/R	48
18. Refrigerant Charging	50
19. Maintenance Procedures	53
20. Maintenance Frequency Checklist.....	55
21. Start Up and Commissioning Report	57

01. Inspections

Information About This Guide

This guide provides installation instructions, specific to your package unit. Read this manual thoroughly and take into consideration all specifications and instructions to ensure correct installation and safe operation of your air conditioning system.

NOTE

Keep this document for future reference. Ensure all technicians that work on the unit can refer to this manual at any time.

Product Inspections

Check your air conditioning unit and all items against the invoice upon receiving your shipment. Inspect the unit, components and accessories for any sign of damage. If there is any damage to the unit, contact ActronAir Customer Care Department immediately on: **1300 522 722** to obtain a Goods Return Number.

Check the unit nameplate to verify the model, serial number and electrical rated specifications.

Codes, Regulations and Standards

The installer and/or contractor assumes responsibility to ensure that unit installation complies with the relevant council, state / federal codes, regulations and building code standards. All electrical wiring must be in accordance with current electrical authority regulations and all wiring connections to be as per electrical diagram provided with the unit.

02. General Information

The ActronAir Variable Capacity air conditioning units are designed for applications where superior performance, high efficiency, reliability, supply air quality and quiet operation are the prime priorities. The units are built with the latest technology, advanced variable speed driven compressor, EC indoor fans (on specific models), low-noise outdoor fans and an intelligent electronic control.

For optimum efficiency, your air conditioning unit will deliver the right amount of cooling or heating capacity that you demand. Even in extreme conditions, the unit will still supply the required demand at peak performance.

Energy Efficient Refrigeration Circuits

The ActronAir Variable Capacity system is designed with a highly efficient refrigeration circuit that delivers only the amount of cooling or heating actually required to maintain your desired comfort at the most optimum efficiency.

The refrigeration circuit consists of:

- High efficiency variable capacity scroll compressor.
- Hydrophilic coated condenser coil designed for optimum performance and efficiency with corrugated fins and riffling tubing.
- Hydrophilic coated evaporator coil designed for optimum performance and efficiency with lanced fins and riffling tubing.
- Electronic expansion valve (EEV), to maintain efficiency at different operating conditions.

Evaporator Section

The evaporator section has EC fans which deliver the right amount of airflow, depending on requirements. The fans provide superior performance for your comfort at optimum efficiency:

- Highly efficient variable speed EC motor that uses less energy than the traditional AC motor.
- Easy indoor fan commissioning via intelligent controllers.
- Low noise operation

Condenser Section

Uses multiple speed outdoor fans and a state of the art digital scroll compressor, with the following features:

- Highly efficient axial fans with direct drive AC motor.
- Variable compressor capacity (20% - 100%).
- Low noise operation

Electrical Section

The electrical section consists of:

- EMC filters
- Switchgears
- 3 Phase motor protection
- 7 Segment Display menu and fault code
- Adjustable indoor airflow pot
- Optional soft start, BMS card, ActronAir Group Control

Durable Design and Construction

ActronAir is an Australian manufacturer with proven high quality air conditioning products. Known for their durability and reliable performance, these products are designed and built to withstand the extreme weather conditions.

The galvanized steel cabinet, with powder coated epoxy enamel finish, resists the toughest conditions. The louvered outdoor coil guard protects the condenser from any potential damage brought by hail, stones and other solid objects that may be projected to the unit.

Blue Hydrophilic coil fins provide protection to your heat exchangers and enhanced heat transfer with increased performance efficiency.

System Flexibility

The ActronAir Variable Capacity range air conditioning units is the first choice for residential and commercial applications, both for new construction or retrofitting projects.

Refrigerant Handling and Accountability

ActronAir strongly urges that all service technicians make every effort possible to reduce the emission of refrigerants to the atmosphere. Everyone must act in a responsible manner to conserve refrigerants in accordance to the industry code of practice.

03. Safety Instructions

- Only licensed HVAC technicians* should install and service this air conditioning equipment. Improper service or alteration by an unqualified technician could result in significant and major damage to the product or property which may render your warranty null and void. Such unqualified service could also lead to severe physical injury or death. Follow all safety instructions in this literature and all warning labels that are attached to the equipment.
- Prevailing WH&S regulations must be observed and will take precedence to the safety instructions contained on this manual. Safe work practices and environment must be the paramount importance in the performance of all the service procedures.
- Ensure that unit installation complies with relevant council regulations and building code standards.
- All electrical wiring must be in accordance with current electrical authority regulations and all wiring connections to be as per electrical diagram provided.
- Secure the fans against accidental contact. Beware of pinch point and sharp edges which can cause cutting injury.
- Always wear appropriate PPE, remove any dangling jewellery and protect long hair by wearing a cap.
- This appliance is not intended for use by young children or infirm persons unless they have been adequately supervised by a responsible person to ensure that they can use the appliance safely. Young children should be supervised to ensure that they do not play with the appliance.
- Installer must incorporate a means of electrical disconnection (isolator) in the sub mains fixed wiring in accordance with the latest edition of the AS/NZS 3000 (also known as Australian Wiring Rules).
- Secure the power cords and control cables that goes in/out the unit. Use the cable ties provided in the control box.

*Qualifications required will be appropriate Electrical, Refrigeration and Refrigerant Handling License and Training dependent on local State/Territory regulations.

 **DANGER****Hazardous Voltage - Risk of Electrocution.**

TURN-OFF the power from main isolator before proceeding with any service work of the unit. Observe proper LOCK-OUT/TAG-OUT (LOTO) procedures for electrical appliances in order to prevent accidental switching-on of the power supply.

 **WARNING**

EC Motors are fitted with high power capacitors and can have dangerous residual voltages at motor terminals after power has been isolated. Wait at least 5 minutes after power isolation and test for any residual voltage before beginning service work.

 **CAUTION****Beware of Rotating Fans !**

Ensure that indoor and outdoor fans are isolated and have come to a complete stand still before servicing the equipment. Beware of pinch point and sharp edges which can cause cutting injury. Secure the fans against accidental contact. Always wear appropriate PPE and remove any dangling jewellery and protect long hair by wearing a cap. Ensure that no loose clothing can be caught / entangled in moving parts.

VISUAL INSPECTION AND WORK ASSESSMENT

Work areas and conditions must first be assessed and evaluated for any potential hazardous conditions. It is also important to be familiar with the unit parts and components before proceeding with any service task.

04. Installation Information

All service technicians handling refrigerant must be licensed to handle refrigerant gases.

Recover and Recycle Refrigerants

Never release refrigerant to the atmosphere! It is an offence in Australia to do so. Always recover, recycle and reuse refrigerants. When removing from the system, properly contain and identify refrigerants in its dedicated container for proper disposal and/or storage. Always consider the recycle or reclaim requirements of the refrigerant before beginning the recovery procedures. Obtain a chemical analysis of the refrigerant if necessary. Refer recovered refrigerant and acceptable refrigerant quality to existing standards and regulations.

Refrigerant Handling and Safety

Consult the refrigerant manufacturer's safety data sheet (SDS) for information on proper handling and to fully understand health, safety, storage and disposal requirements. Use the approved containment vessels and refer to appropriate safety standards. Comply with all applicable transportation standards when shipping refrigerant containers.

Service Equipment and Recovery Procedures

Always use refrigerant reclaiming equipment in order to minimise refrigerant emissions. Use equipment and methods which will pull the lowest possible system vacuum while recovering and condensing refrigerant. Equipment capable of pulling a vacuum of less than 500 microns is required.

Do not open the system to the atmosphere for service work until refrigerant is fully removed and/or recovered. Perform refrigeration system evacuation, prior to charging, in accordance with AIRAH / IRHACE Refrigerant handling code of practice.

Let the unit stand for 1 hour and with the vacuum not rising above 500 microns. A rise above 500 microns indicates a leak from the system and a leak test is required to locate and repair any leak.

 **CAUTION**

A leak test is always required on any repaired section of the refrigeration system.

Charge refrigerant into the system only after the equipment does not leak or contain moisture. Ensure that R-410A is only charged in liquid form. Take into consideration the correct amount of refrigerant charge specified for the system to ensure efficient unit operations. When charging is complete, reclaim refrigerant from charging lines into an approved refrigerant container. Seal all used refrigerant containers with approved closure devices to prevent unused refrigerant from escaping to the atmosphere. Take extra care to maintain all service equipment directly supporting refrigerant service work such as gauges, hoses, vacuum pumps and recycling equipment.

INSTALLATION PREPARATION (Pre-installation considerations)

The following items must be considered before beginning the unit installation:

- Verify the unit capacities and ratings with the unit nameplate.
- Make certain the floor or foundation is level, solid and have sufficient structural strength to support the unit and accessories weight.
- Preferably use anti-vibration rubber pads on residential units.
- Allow minimum recommended clearances for periodic maintenance and service access.
- Allow sufficient space above the unit for the outdoor air discharge. Condenser air inlet, located on the coil side of the unit, requires sufficient airflow clearance for the optimum unit performance.
- Note the conditioned supply air and return air location. Ensure sufficient spaces are allocated for these purposes.
- Refer connection and location of condensate drain in the unit drawing and dimensions section of this manual.
- Wiring connections must be in accordance with the wiring diagram provided with the unit.
- Make sure all wirings are in accordance with local electricity authority regulations and standards.
- Do not install the unit close to an area where there is a danger of fire due to volatile, explosive, flammable and/or hazardous materials.
- Ensure that spaces around the unit are free from any obstructions for optimum unit performance.
- Installer to ensure correct size/type that main circuit breaker and cable is installed in unit sub-mains to protect the sub-mains and unit wiring.
- Installer to ensure correctly rated residual current device (RCD) is installed as per with the latest edition of the AS/NZS 3000 (also known as Australian Wiring Rules).
- Secure the power cords and control cables that goes in/out the unit. Use the cable ties provided in the control box.

NOTES

- This unit is supplied with factory charged R-410A refrigerant.
- Be aware of all the relevant regulations concerning the handling of refrigerant.

05. Wall Control Operation Manual Access

Download from website

LC7-2

Operation Instruction can be downloaded through our website shown below.

<https://www.actronair.com.au/brochures-manuals/#operating-manuals>

NEO

Operation Instructions can be accessed through our website shown below.

<http://neo.actronair.com.au/user-guide/>

06. Components Overview

PACKAGE UNIT COMPONENTS OVERVIEW

Left Hand (LH) Side By Side Configuration shown for illustration purposes only

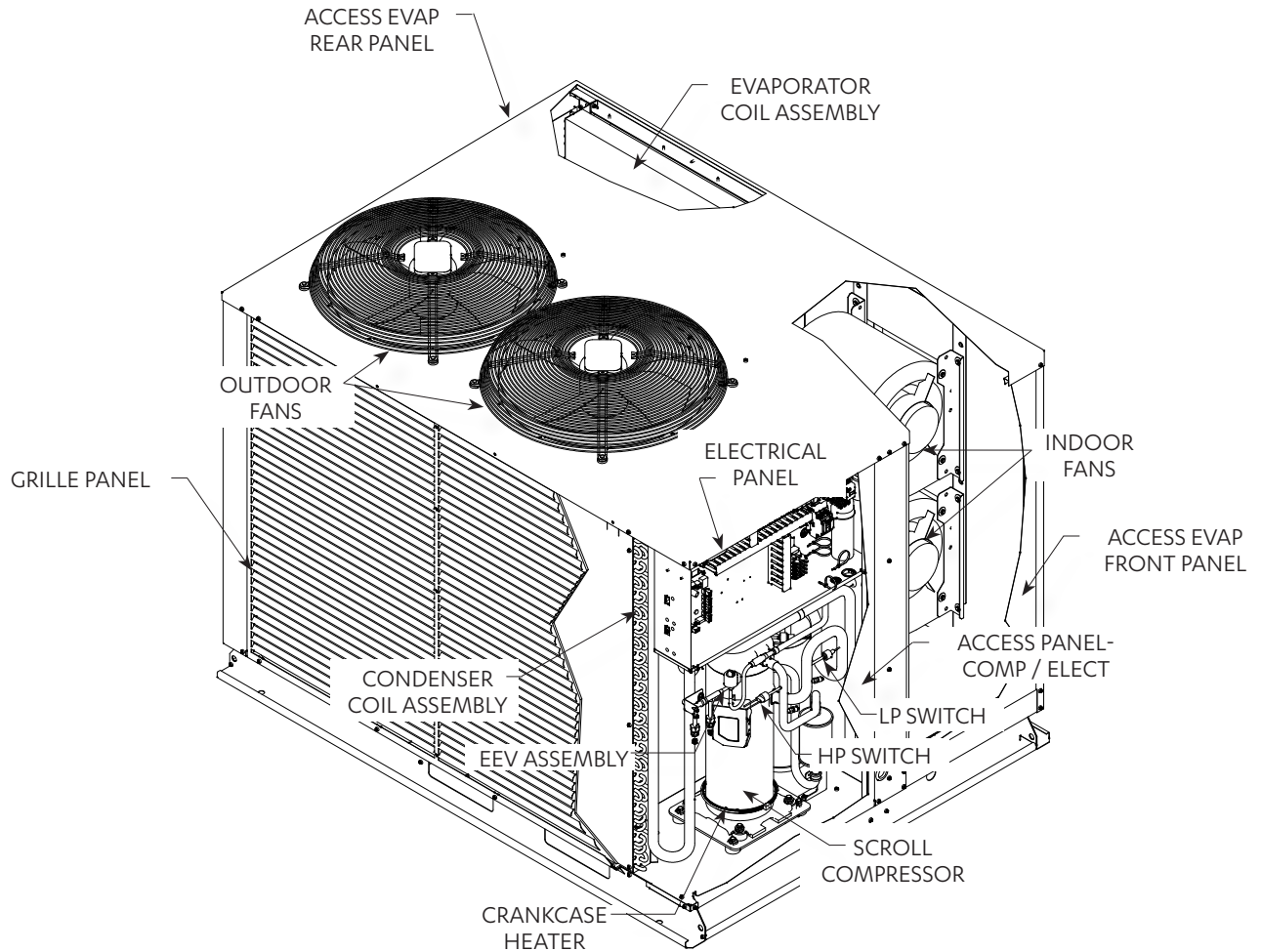

OUTDOOR UNIT ELECTRICAL PANEL OVERVIEW

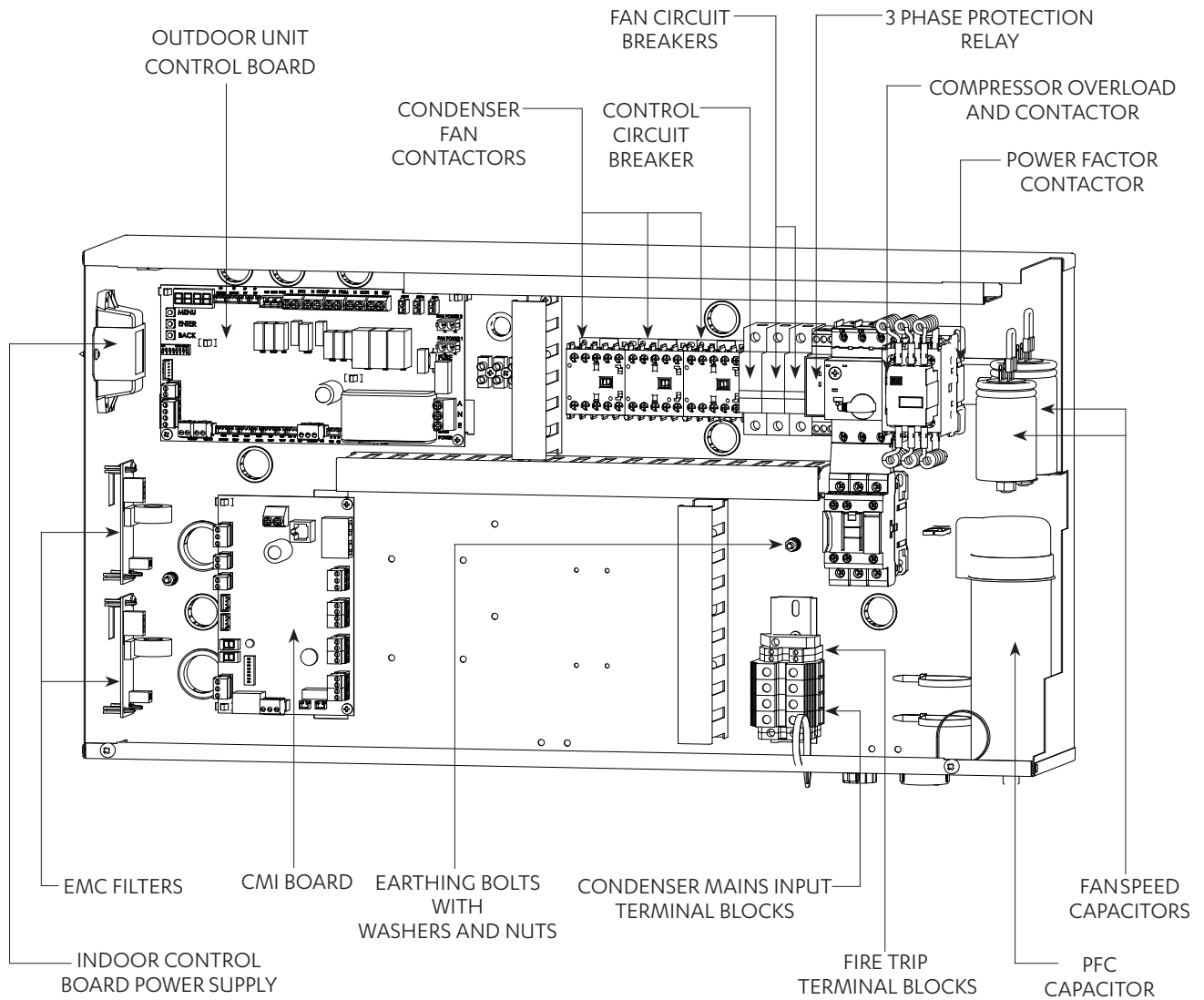

07. Package Unit Dimensions / Clearances

07.01. Package Model : PKV290T-T / PKV330T-T

OVERALL NOMINAL DIMENSION (H x W x L)
 = 1420 x 1840 x 1440
 SUPPLY DUCT (H x W) = 283 x 1098
 RETURN DUCT (H x W) = 547 x 1453
 DRAIN CONNECTION = DN 25mm PN12

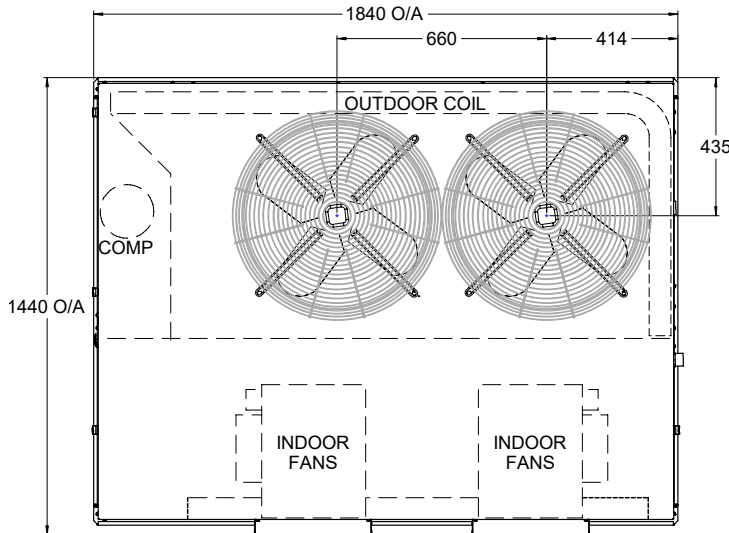

TOP VIEW

NOTES:

1. Do not scale drawing. All dimensions are in mm unless specified. Refer to corresponding unit dimensional drawing for mounting hole details.
2. Service Access Areas and Spaces for Airflow Clearances given are suggested minimum based on the condition that the spaces around the units are free from any obstructions and a walkway passage of 1000mm between the units or between the unit and the outside perimeter is available.
3. Minimum service access areas and spaces for airflow clearances are responsibilities of the installer, ActronAir will not be held liable for any extra charges incurred due to lack of access and space for airflow.
4. Under all circumstances, condenser air must not recirculate back onto condenser coil. Keep all clearance free of any obstructions.
5. STACKING OF UNITS: Ensure that minimum airflow and clearances are met.
6. MTG C-C DIST = Mounting Centre to Centre Distance.
7. Use M12 bolt for feet mounting.

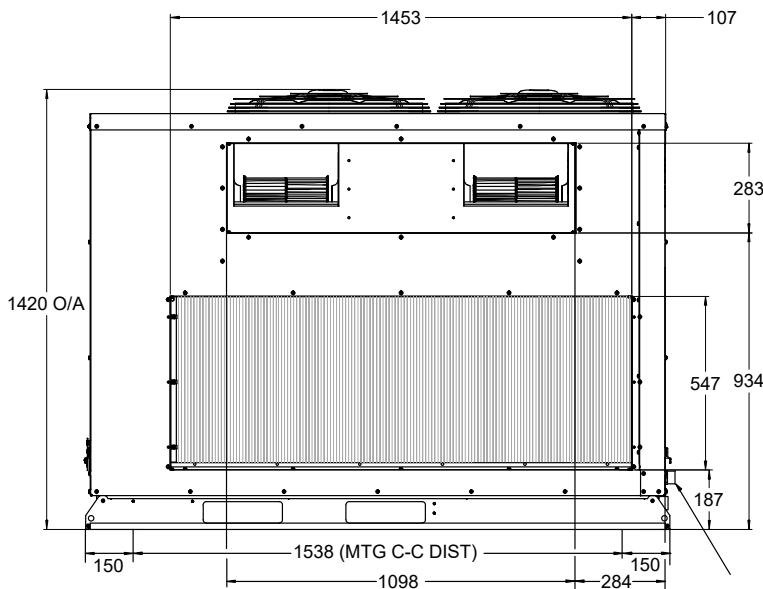
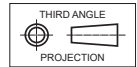

FRONT VIEW

CONDENSATE
 DRAIN POINTS
 DN 25mm PN12

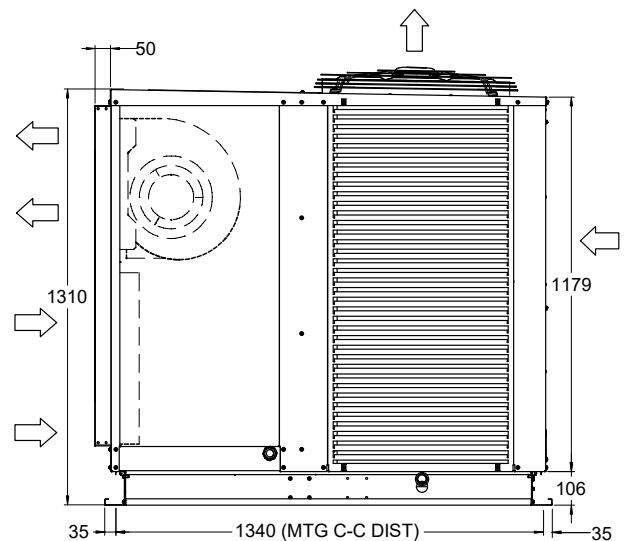

SIDE VIEW

Minimum Service Access Clearances and Airflow Space Allowances

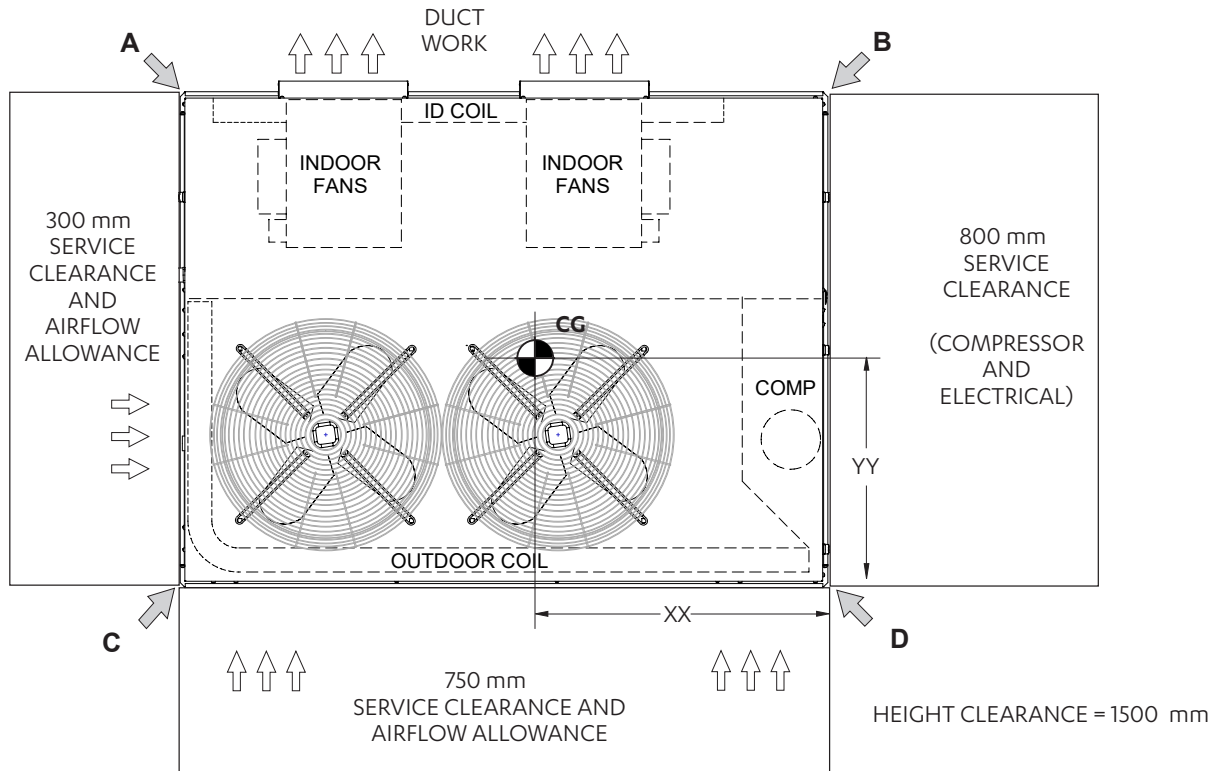

NOTE

- Under all circumstances, Condenser Air must not recirculate back onto Condenser Coil.
- Keep all clearances free of any obstructions.

Base Mounting Details

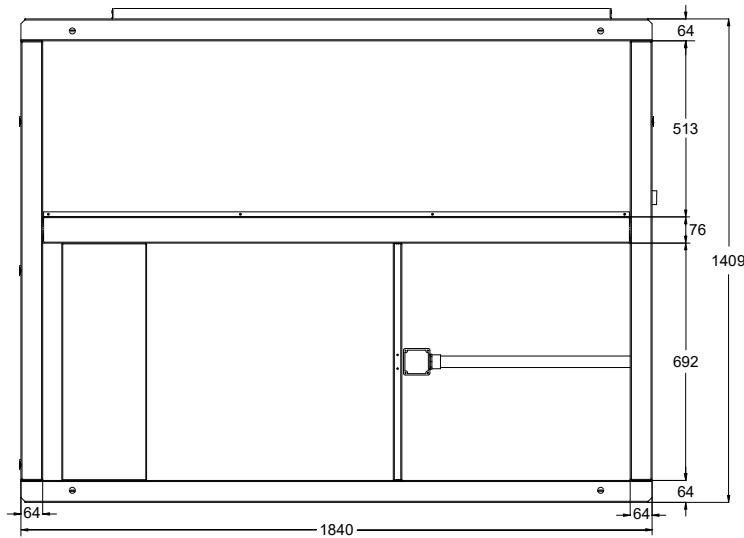

Unit Model Number	Unit Weight (Kg)	Corner Weights (Kg)				Center of Gravity	
		A	B	C	D	XX	YY
PKV290T-T	400	121	66	56	157	813	660
PKV330T-T	433	124	70	63	176	813	660

07.02. Package Model : PKV290T-L/PKV330T-L L - left Hand Air Handling Configuration

OVERALL NOMINAL DIMENSION (H x W x L)
= 1420 x 1840 x 1440
SUPPLY DUCT (H x W) = 788 x 368
RETURN DUCT (H x W) = 1072 x 753
DRAIN CONNECTION = DN 25mm PN12

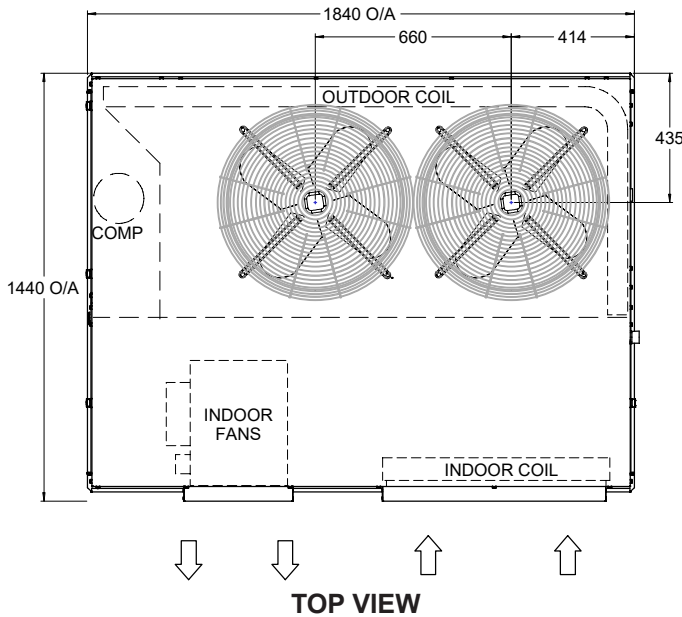

NOTES:

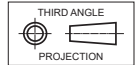

1. Do not scale drawing. All dimensions are in mm unless specified. Refer to corresponding unit dimensional drawing for mounting hole details.
2. Service Access Areas and Spaces for Airflow Clearances given are suggested minimum based on the condition that the spaces around the units are free from any obstructions and a walkway passage of 1000mm between the units or between the unit and the outside perimeter is available.
3. Minimum service access areas and spaces for airflow clearances are responsibilities of the installer, ActronAir will not be held liable for any extra charges incurred due to lack of access and space for airflow.
4. Under all circumstances, condenser air must not recirculate back onto condenser coil. Keep all clearance free of any obstructions.
5. STACKING OF UNITS: Ensure that minimum airflow and clearances are met.
6. MTG C-C DIST = Mounting Centre to Centre Distance.
7. Use M12 bolt for feet mounting.

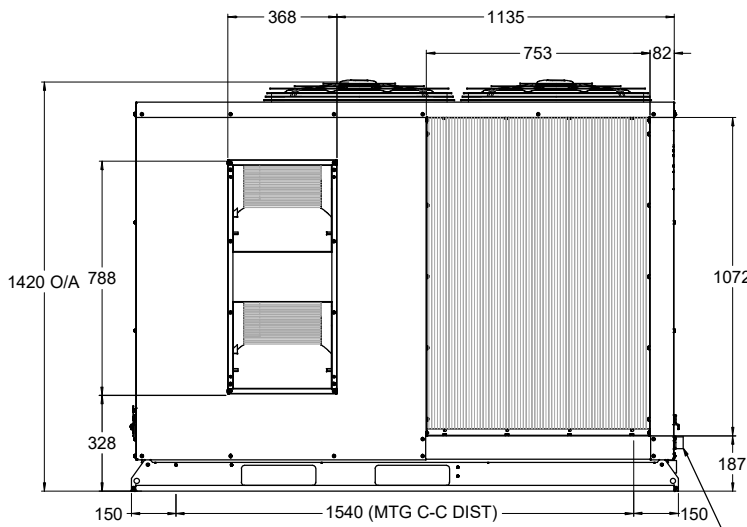

CONDENSATE
DRAIN POINTS
DN 25mm PN12

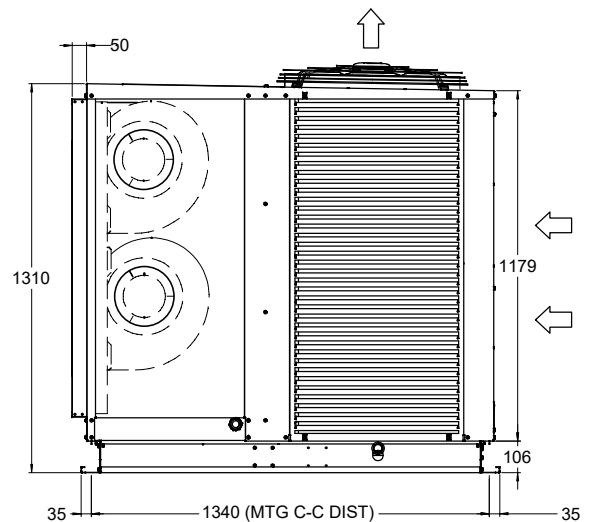

Minimum Service Access Clearances and Airflow Space Allowances

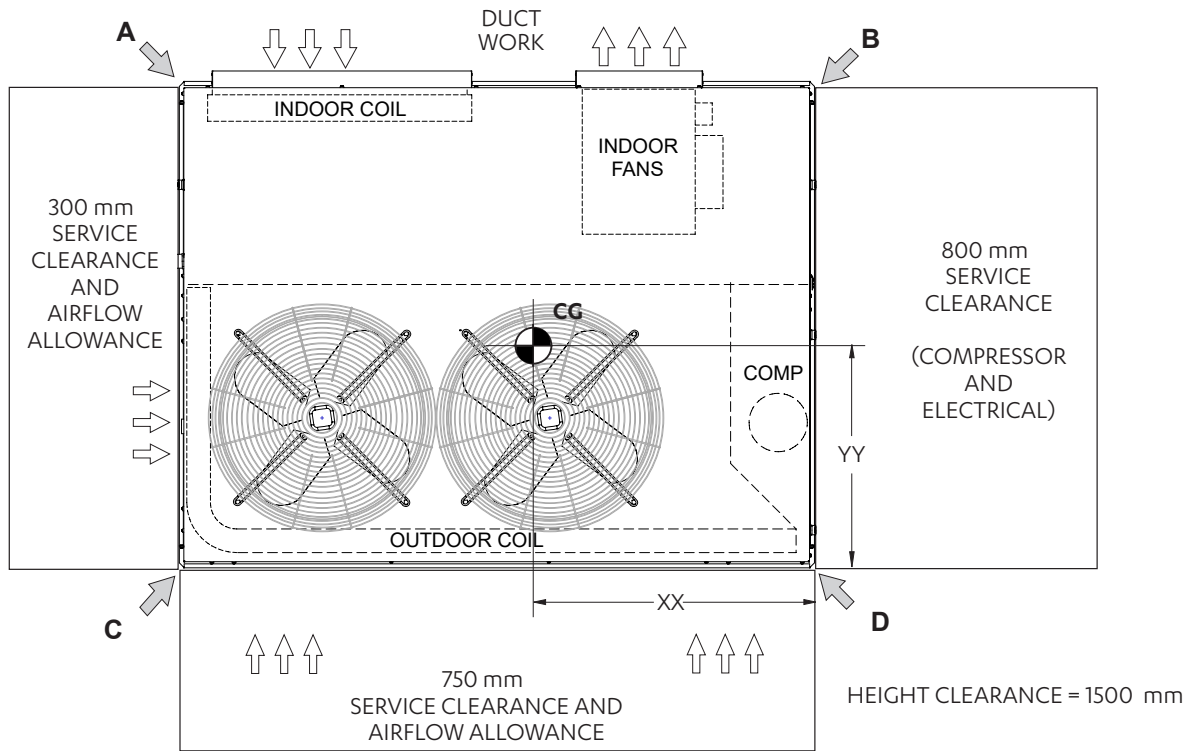

NOTE

- Under all circumstances, Condenser Air must not recirculate back onto Condenser Coil.
- Keep all clearances free of any obstructions.

Base Mounting Details

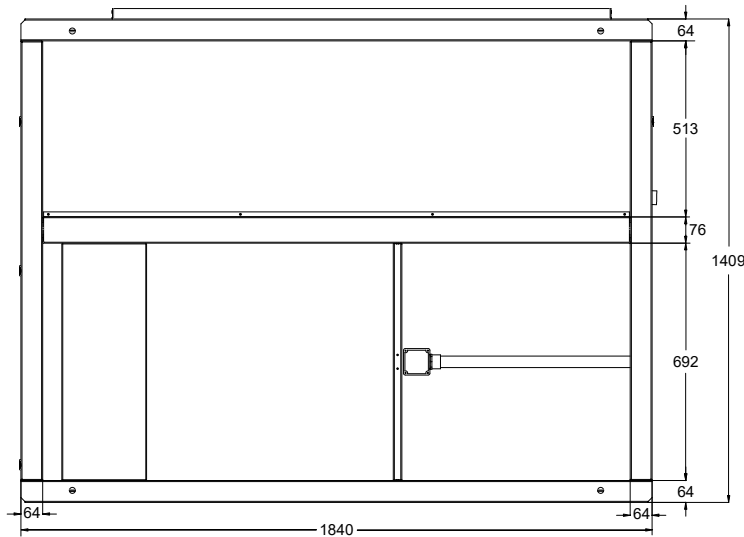

Unit Model Number	Unit Weight (Kg)	Corner Weights (Kg)				Center of Gravity	
		A	B	C	D	XX	YY
PKV290T-L	399	116	70	56	157	813	660
PKV330T-L	432	120	73	63	176	813	660

07.03. Package Model : PKV290T-R / PKV330T-R
R - Right Hand Air Handling Configuration

OVERALL NOMINAL DIMENSION (H x W x L)
 = 1420 x 1840 x 1440
 SUPPLY DUCT (H x W) = 788 x 368
 RETURN DUCT (H x W) = 1072 x 753
 DRAIN CONNECTION = DN 25mm PN12

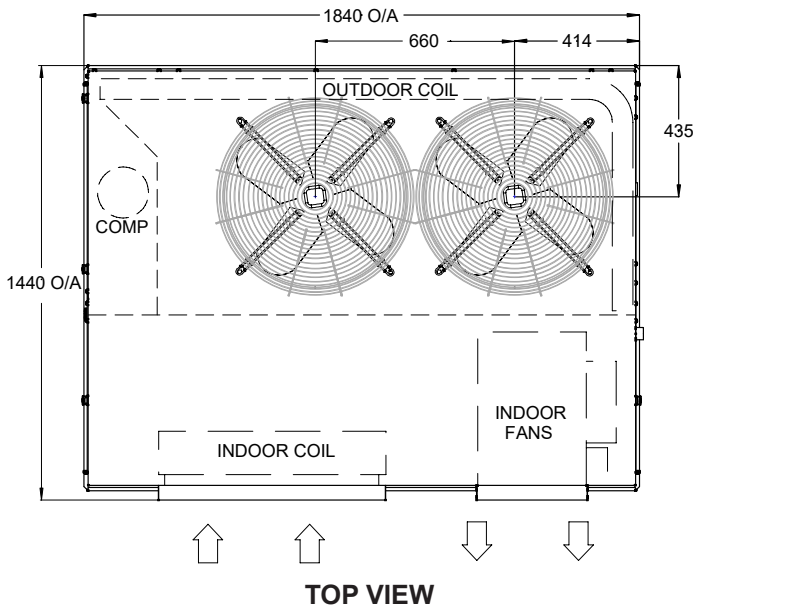

NOTES:

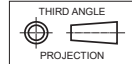

1. Do not scale drawing. All dimensions are in mm unless specified. Refer to corresponding unit dimensional drawing for mounting hole details.
2. Service Access Areas and Spaces for Airflow Clearances given are suggested minimum based on the condition that the spaces around the units are free from any obstructions and a walkway passage of 1000mm between the units or between the unit and the outside perimeter is available.
3. Minimum service access areas and spaces for airflow clearances are responsibilities of the installer, ActronAir will not be held liable for any extra charges incurred due to lack of access and space for airflow.
4. Under all circumstances, condenser air must not recirculate back onto condenser coil. Keep all clearance free of any obstructions.
5. STACKING OF UNITS: Ensure that minimum airflow and clearances are met.
6. MTG C-C DIST = Mounting Centre to Centre Distance.
7. Use M12 bolt for feet mounting.

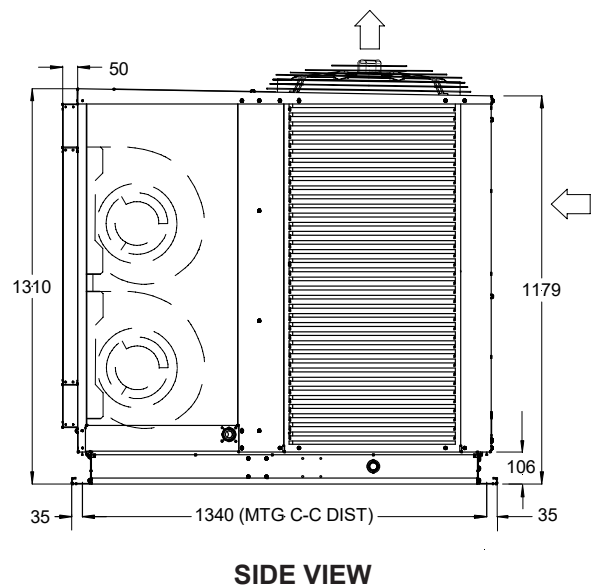
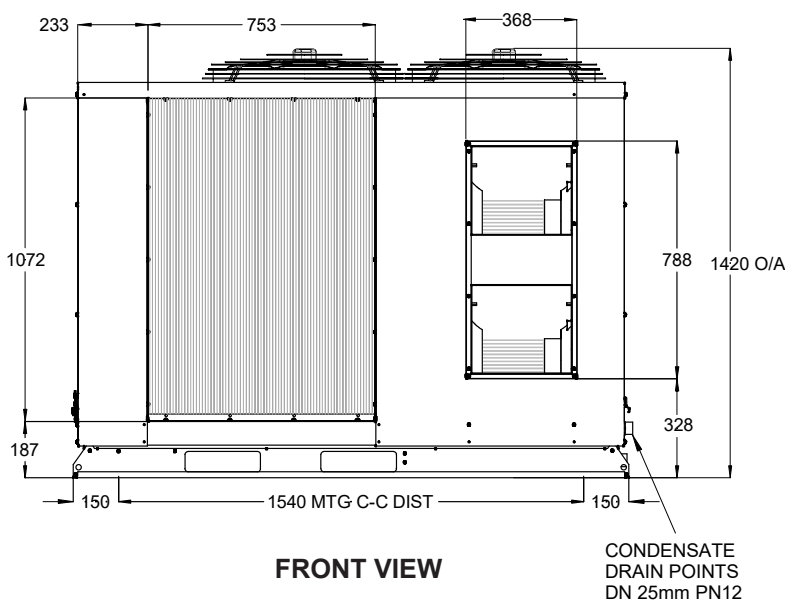

Minimum Service Access Clearances and Airflow Space Allowances

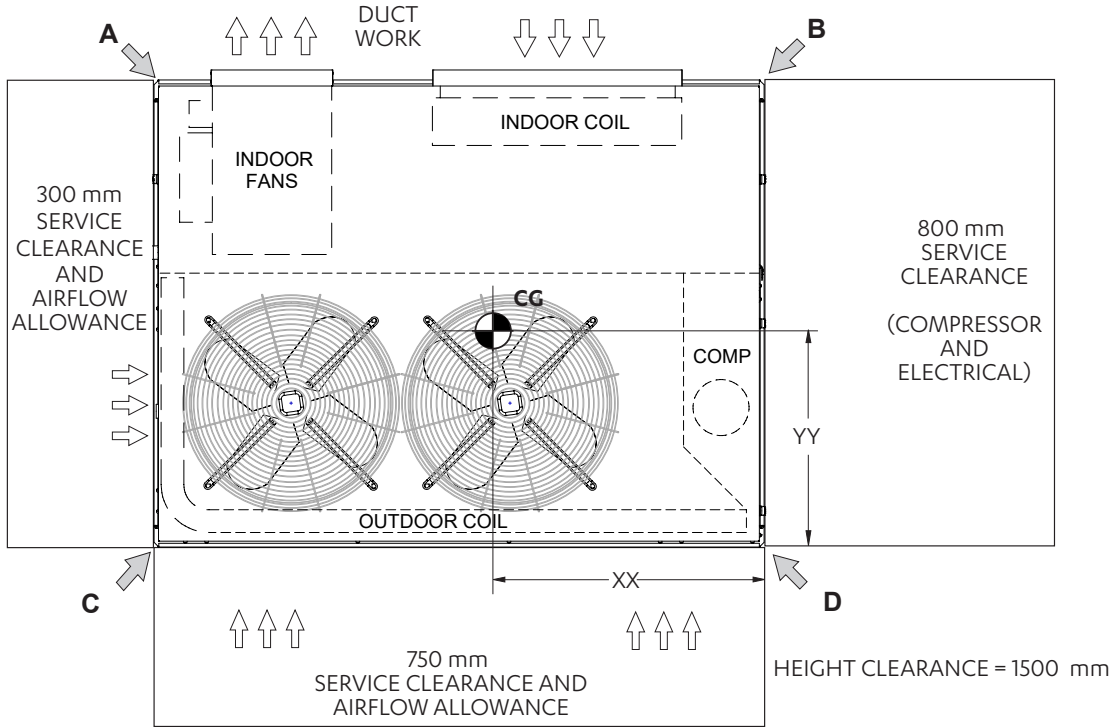

NOTE

- Under all circumstances, Condenser Air must not recirculate back onto Condenser Coil.
- Keep all clearances free of any obstructions.

Base Mounting Details

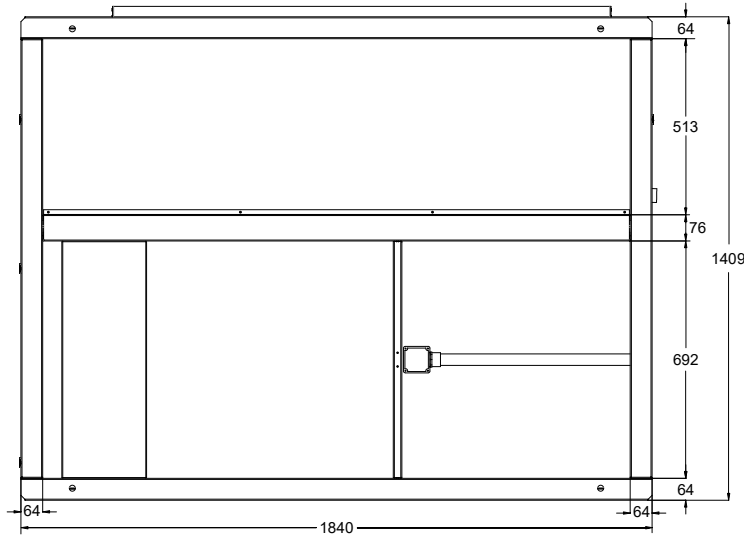

Unit Model Number	Unit Weight (Kg)	Corner Weights (Kg)				Center of Gravity	
		A	B	C	D	XX	YY
PKV290T-R	399	70	116	56	157	813	660
PKV330T-R	432	73	120	63	176	813	660

08. Unit Lifting Procedure

WARNING

WH&S regulations must be observed and will take precedence during lifting process.

Crane Lifting Method

Note: Crane lifting method is recommended for high rise lifting.

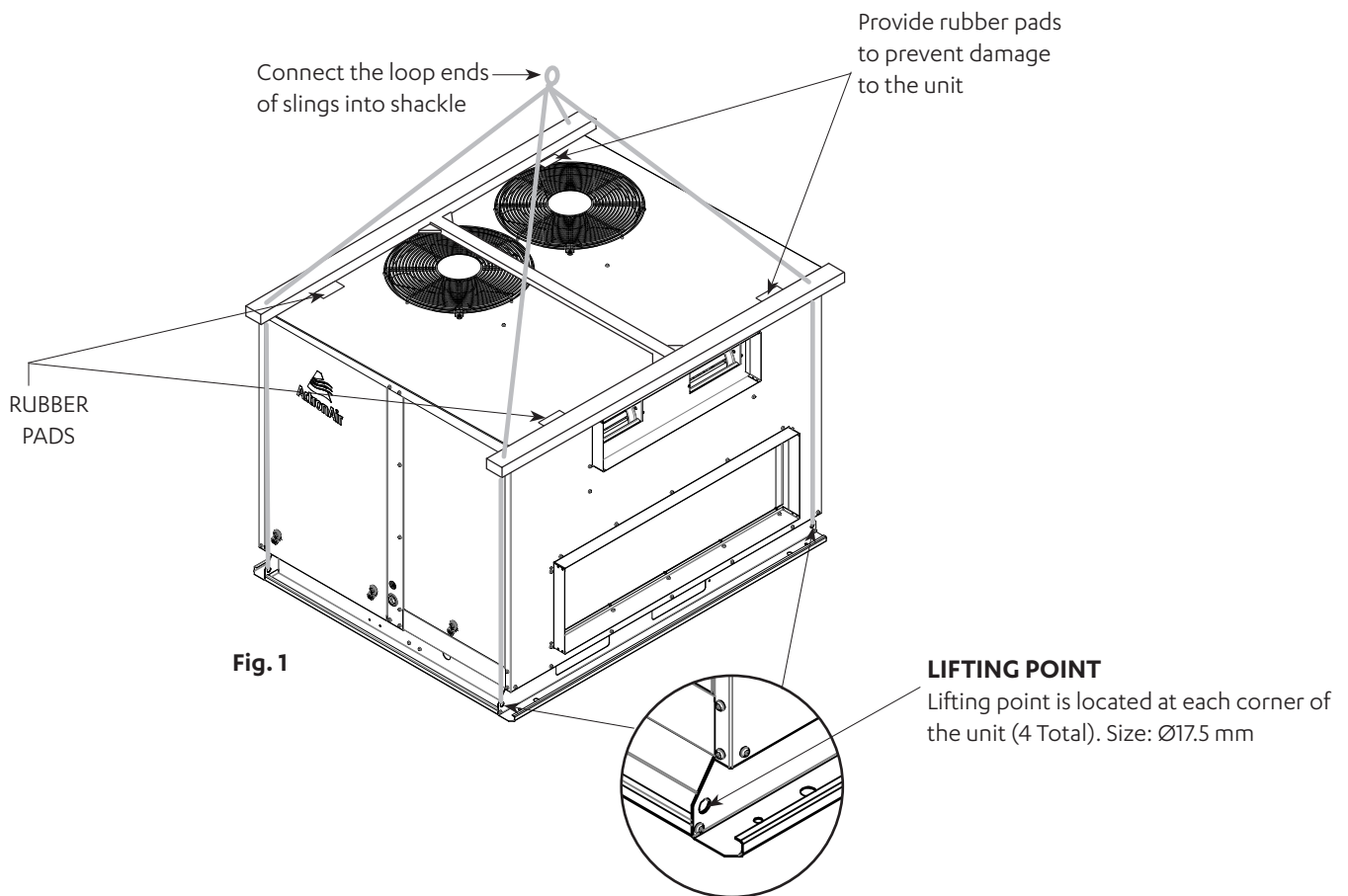

EQUIPMENT REQUIRED FOR CRANE LIFTING:

- 1 x Shackle
- 2 x Nylon Slings
- Spreader Bar

NOTE

Refer to Unit Dimensions and Clearances section for unit weight before selecting shackles and slings.

Procedure:

1. Remove all screws and washers that secure the unit to the timber pallet.
2. Use 4 x Bow or Dee shackle to connect the lifting holes.
3. Slip nylon slings through all shackles.
4. Ensure slings are protected by rubber pads or similar if slings are draped across the unit edges and corners. This will prevent the unit from being damaged during lifting.
5. SPREADER BAR must be used when lifting the unit.

⚠ DANGER

Make sure rigging equipment, accessories and plant are sufficiently and safely capable to lift the unit in order to prevent potential damage to property, severe personal injury or death. Check unit weight and weight distribution points on unit drawing dimensions section.

NOTES

- Lifting procedure and unit model shown are suggestions and for illustration purposes only.
- It is highly recommended that installer observe current industry safe and sound rigging and lifting procedure.

⚠ CAUTION

Length of fork lift tines must pass the unit middle section, in order to safely carry the unit.

Fork Lift Method

Procedure:

1. To move the unit around with a forklift, insert the fork tines through the unit feet assembly, as shown in Fig. 2.
 2. Only fork the unit through compressor end or side of the unit.
- (See illustration for location of compressor end)

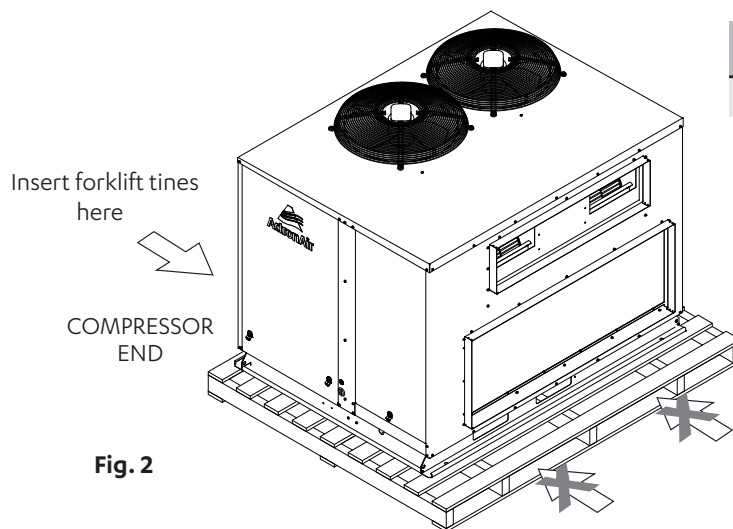

Fig. 2

⚠ CAUTION

DO NOT LIFT from this end

09. Outdoor Unit Preparation

NOTE

It is important to remove the shipping blocks before unit operation.

Step 1. Remove Access Panel, as shown below:

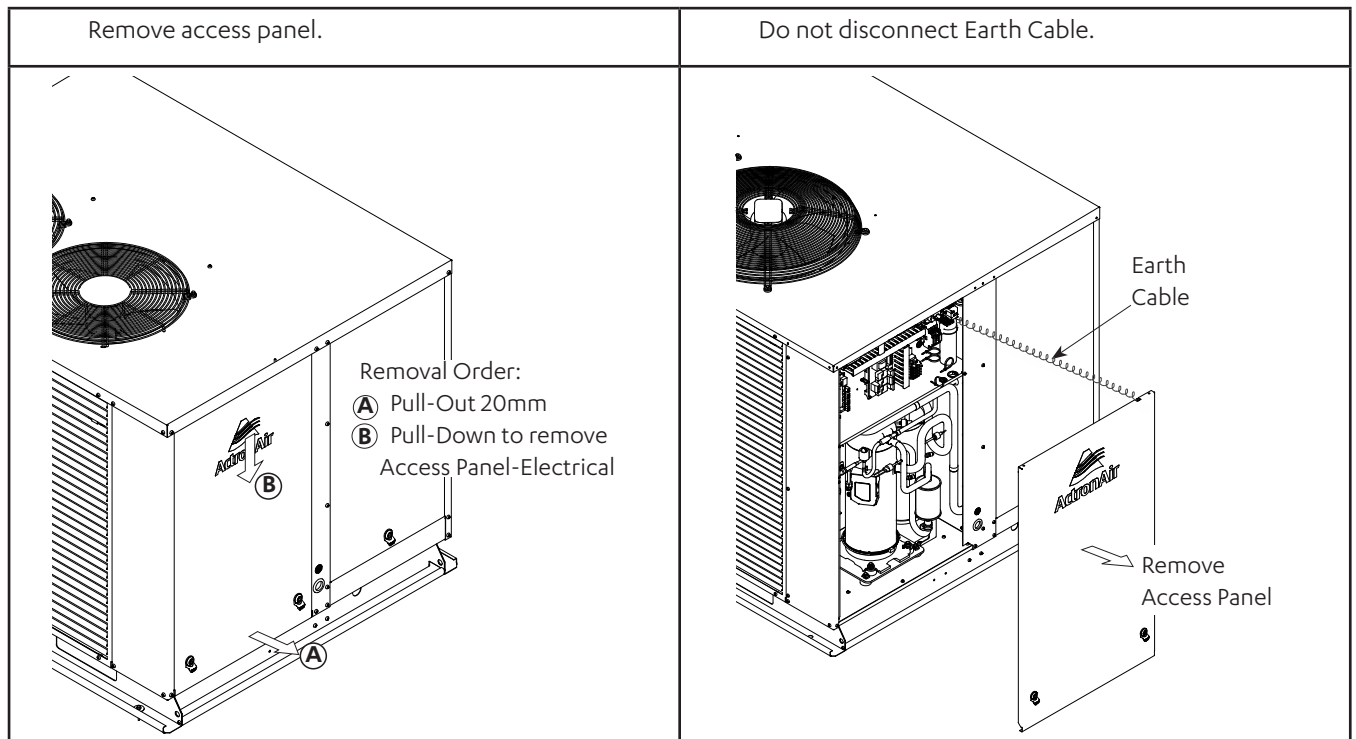
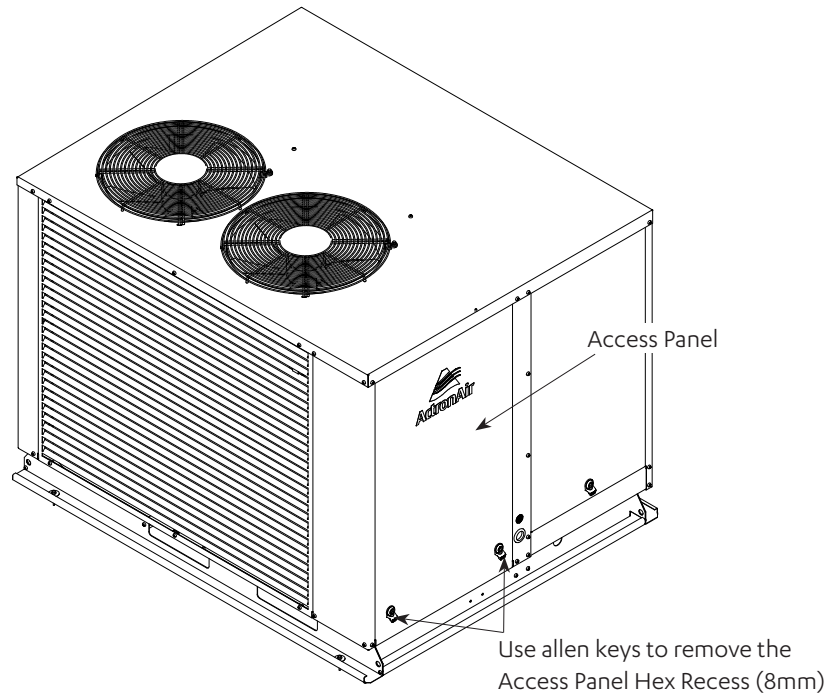

Step 2. Remove Shipping Blocks.

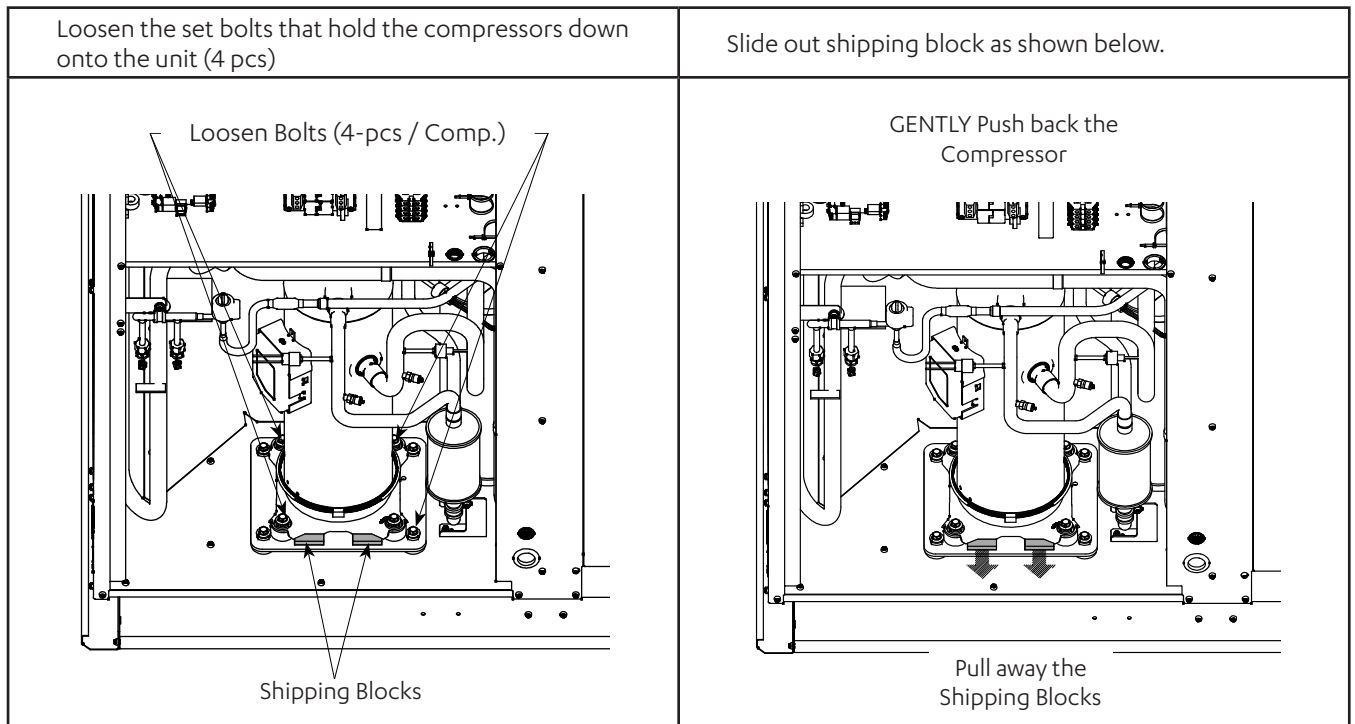

Step 3. Tighten back the set bolts that hold the compressors down onto the unit (4 pcs)

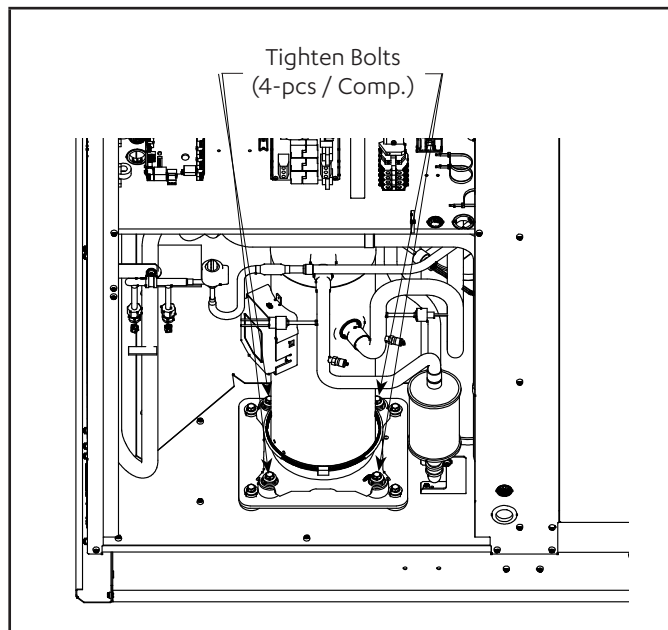

10. Condensate Drainage Instructions

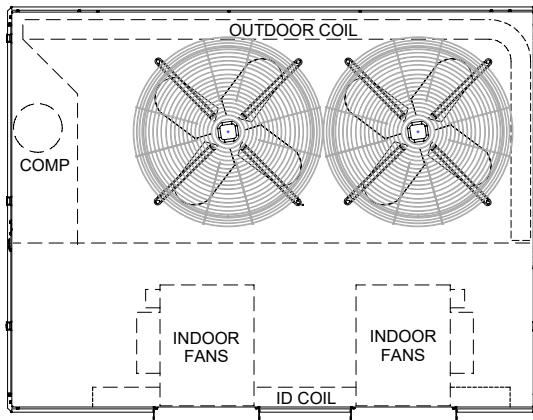

TOP VIEW

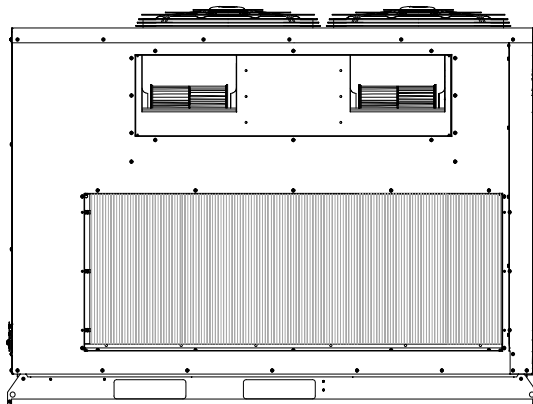

FRONT VIEW



Ensure Condensate Drain Connection Drain Pipe slopes down from the unit at a minimum of 10mm per meter.

NOTES

- Ensure that Condenser and Evaporator condensate drains are connected separately.
- Do not use pipes or tube coming out from the unit to lift the unit.
- Support drain line for long pipe run.
- Parts for the Condensate Trap are not supplied with the unit.
- Refer to unit dimension page for specification of drain connectors.
- Test condensate drain installation to ensure that water flows freely and does not leak. Also check that the drain tray does not overflow.
- All drawings are for illustration purposes only. Actual unit may vary depending on the model.

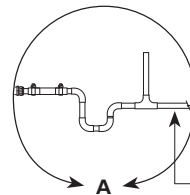

Ensure Condensate Drain Connection Drain Pipe slopes down from the unit at a minimum of 10mm per meter.

SUGGESTED DRAIN TRAP DETAILS

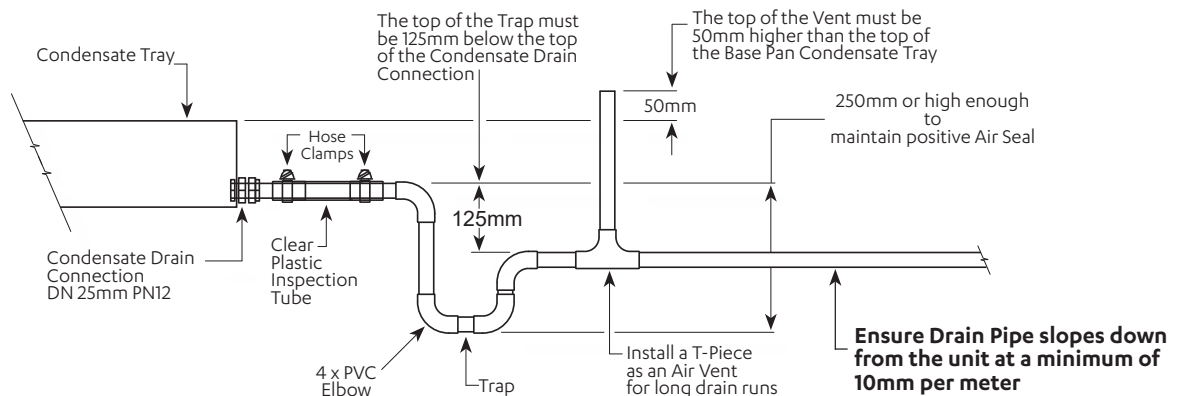

DETAIL A

11. Electrical Installation

All electrical work must be carried out by a qualified technician. Make sure all wiring is in accordance with local wiring rules. Wiring connections should be made in accordance with the wiring diagram provided.

DANGER

Live Electrical Supply !

- During installation of your air conditioning unit, it may be necessary to work in close proximity to live electricity.
- Only qualified technicians are allowed to perform these tasks.
- Follow all electrical safety precautions when exposed to live electrical components.

Wiring Diagram

The wiring diagram specific for your air conditioning system is located on the inside panel of the control access door. Always refer all wiring installation, servicing and troubleshooting of this equipment to this diagram to ensure correct electrical connection are satisfied.

Supply Power Requirements and Procedures

It is the installer's responsibility to provide power supply wiring to the unit's Mains Power Supply terminal block. Make sure all wirings are in accordance with local wiring rules. Wiring should conform to all current electrical authority regulations and all wiring connections to be as per electrical diagram provided with the unit.

- Confirm that the power supply available is compatible with the unit nameplate ratings. The supply power must be within +6% to -6% of the rated voltage as per AS60038.
- Protect electrical service from over current and short circuit conditions in accordance with the latest edition of the AS/NZS 3000 "Australian / New Zealand Wiring Rules". Size protection devices according to the electrical data of the unit.
- Secure the power cords and control cables that goes in/out the unit. Use the cable ties provided in the control box.
- Provide the proper unit earthing in accordance with the local and national codes.

Compressor Voltage Balance Requirement

Check the voltage at the compressor terminals to determine if it is balanced. Voltage imbalance on three phase systems can cause motor overheating and premature failure. The maximum allowable imbalance is $\pm 2.0\%$, check the unit wiring connections to locate and rectify the faults, should the voltage imbalance exceed this value.

NOTES

- Parts for the Condensate Trap are not supplied with the unit.
- Refer to Unit Drawing and Dimensions page of the Technical Selection Catalogue for specifications and details of drain connectors.

12. Package Unit Electrical Connection

DETAILED WIRING DIAGRAM IS PROVIDED WITH THE UNIT

Condenser Side: Located at the back of electrical/compressor access panel.

- ① THREE PHASE MAINS WIRING (400 VAC)
(Three Phase +Neutral+Earth) 50Hz
- ② DATA CABLE TO WALL CONTROL
(Cat5E UTP (AWG 24) Data Cable)

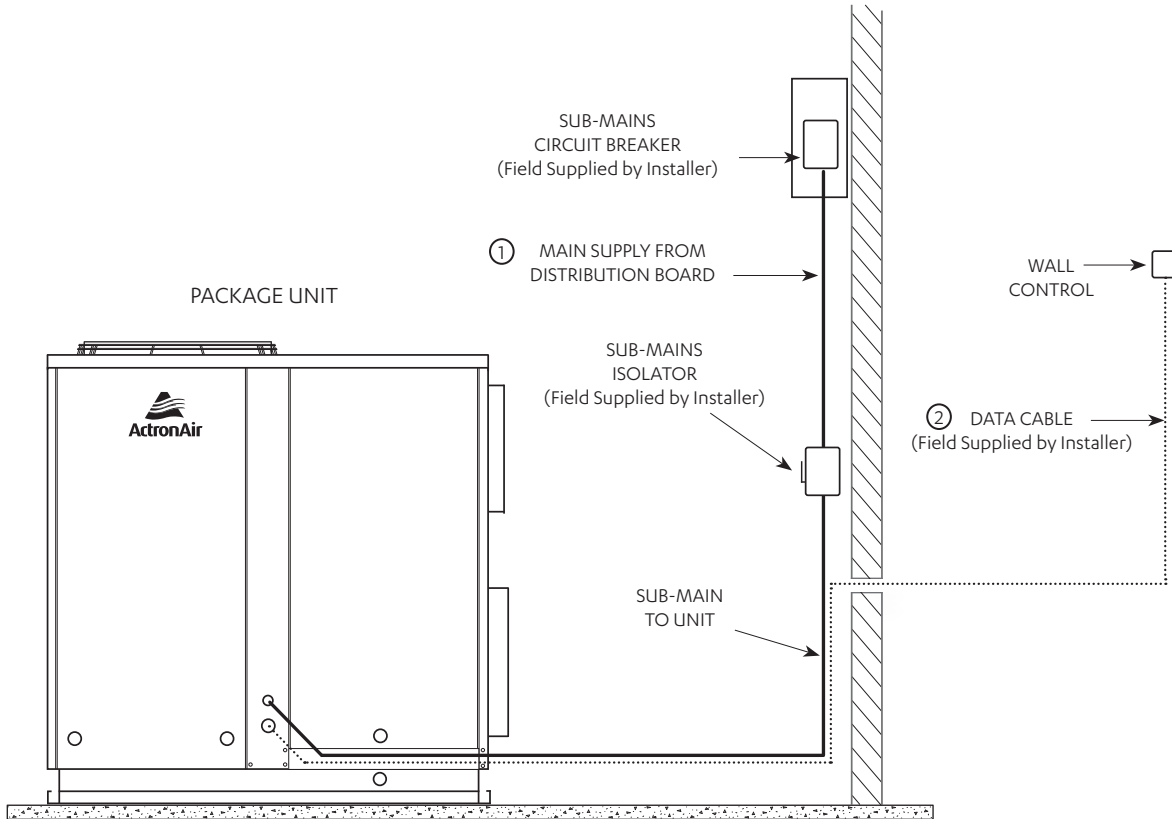

NOTE

PKV shown for illustration purposes only.

Circuit Breaker Size Recommendation

Model	Circuit Breaker Size Amps
PKV290T-T	32.0
PKV330T-T	32.0
PKV290T-L/R	32.0
PKV330T-L/R	32.0

* Refer to latest edition of AS/NZS 3000 or AS/NZS 3008 Australian/New Zealand Wiring Rules to determine required cable size.

13. Maximum Cable Length

13.01. Wall Controller Options

Maximum of three (3) wall controllers in below combinations is allowed on unit. See below table.

Combinations	Wall Controllers		
	WC1	WC2	WC3
1st Option	NEO		
2nd Option	NEO	NEO	
3rd Option	NEO	NEO	LC7-2
4th Option	NEO	LC7-2	
5th Option	NEO	LC7-2	LC7-2
6th Option	LC7-2		
7th Option	LC7-2	LC7-2	
8th Option	LC7-2	LC7-2	LC7-2

NOTES

- NEO - Available in White (NTW-1000) and Black (NTB-1000) colours.
- LC7-2 - Available in White and Grey colours.
- In the instance of a combination of NEO and LC7-2 being connected together, the NEO will always need to be addressed as C1.

13.02. Wiring Configuration 1: Recommended

NOTES

- Diagram shown below is a general representation only. Refer to individual unit wiring diagram for complete wiring connection details.
- Long runs beside Mains cables or TV antenna cables should be avoided.
- Wiring configuration for LR7-1 and LC7-2 wall controller is the same.
- Daisy connection is not allowed for the NEO wall controller.
- Two Ferrite Clips*, if supplied, are to be placed 200mm and 400mm from the NEO controller.

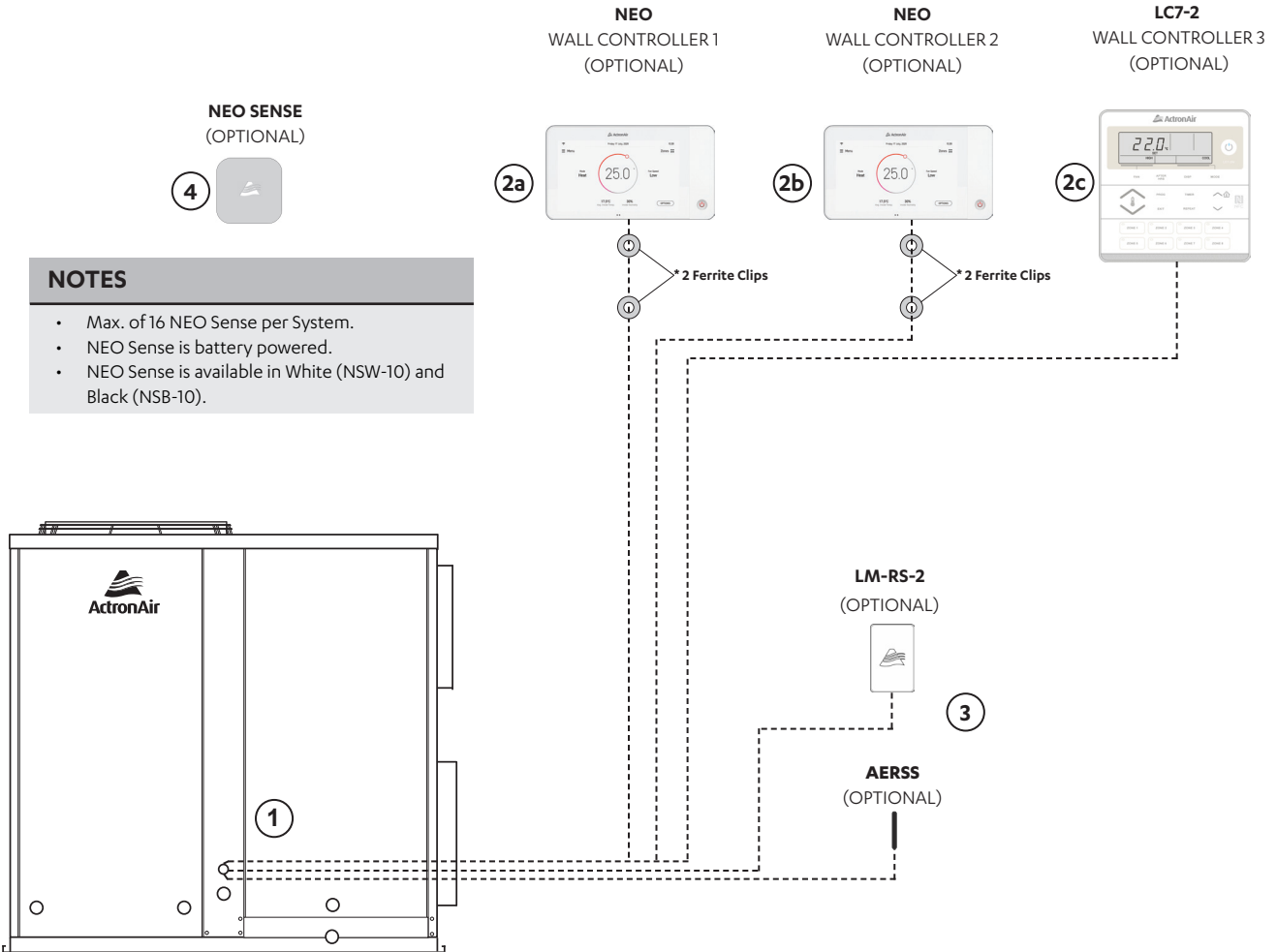

NOTES

- Max. of 16 NEO Sense per System.
- NEO Sense is battery powered.
- NEO Sense is available in White (NSW-10) and Black (NSB-10).

Item	Description	Maximum Cable Length
1 to 2a, 1 to 2b	Indoor PCB to Wall Control 1 and 2	90 m
1 to 2c	Indoor PCB to Wall Control 3	100 m
1 to 3	Indoor PCB to Remote Sensor	100 m

Description	Cable Type
LC7-2 and NEO Field Control Wiring	Cat5E UTP (AWG 24) Data Cable
Indoor to Remote Sensor	Cat5E UTP (AWG24) Data Cable

13.03. Wiring Configuration 2 : Alternate

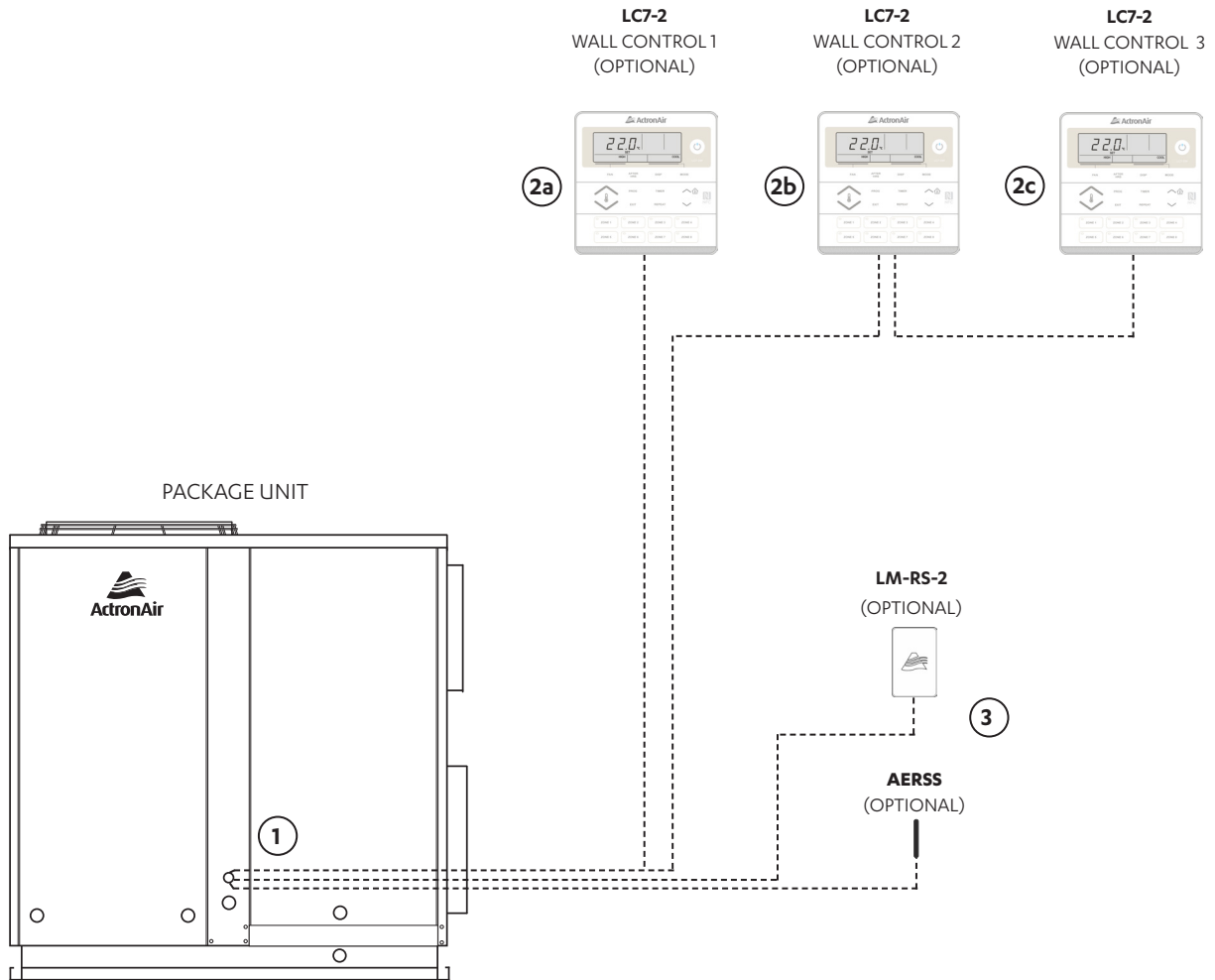

NOTES

- Diagram shown above is a general representation only. Refer to individual unit wiring diagram for complete wiring connection details.
- Long runs beside Mains cables or TV antenna cables should be avoided where possible.

ITEM	DESCRIPTION	MAXIMUM CABLE LENGTH
1 to 2a	Indoor PCB to Wall Control 1 (optional)	100 m
1 to 2c	Indoor PCB to Wall Control 3 (optional)	75m total (Daisy Chain)*
1 to 3	Indoor PCB to Remote Sensor	100 m

* Maximum Daisy Chain connection is up to 2 Wall Control.

DESCRIPTION	CABLE TYPE
LC7-2 Field Control Wiring	Cat5E UTP (AWG 24) Data Cable
Indoor to Remote Sensor	Cat5E UTP (AWG24) Data Cable

14. Wiring Connections

14.01. LC7-2 Wall Control Wiring Connections

WALL CONTROL WIRING

POWER: - BROWN / ORANGE
 485 A: - BLUE
 485 B: - BLUE-WHITE
 GND: - BROWN-WHITE / ORANGE-WHITE
 NOT USED: - GREEN / GREEN-WHITE

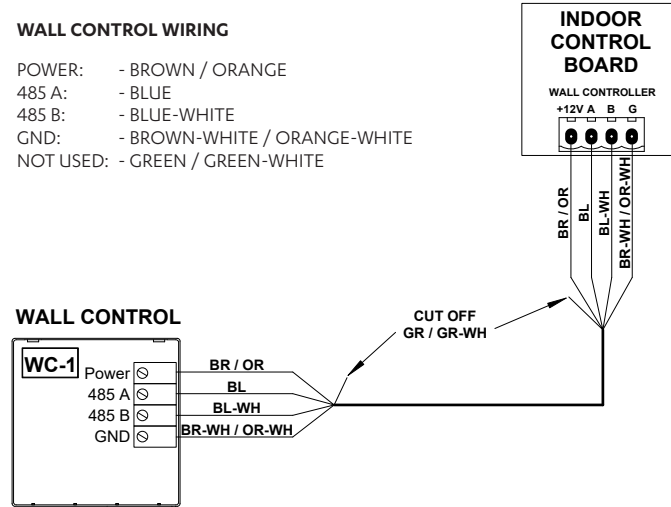

14.02. NEO Wall Control Wiring Connections

NOTE

Two FERRITE CLIPS, if supplied, should be installed 200 mm away and FERRITE 2 should be 400 mm away from the Wall Control.

14.02.01. NEO RJ45 Wiring

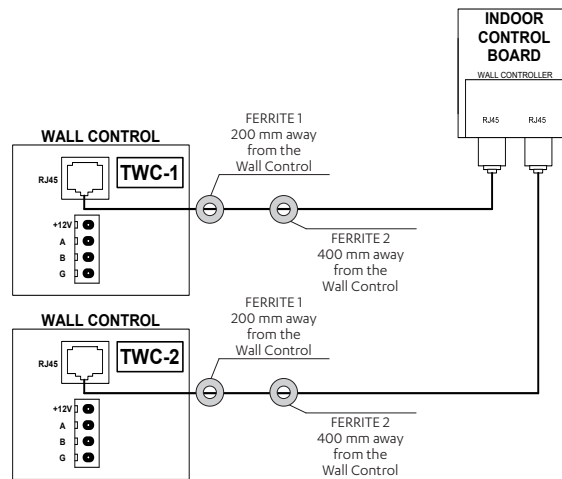

14.02.02. NEO Hard Wiring

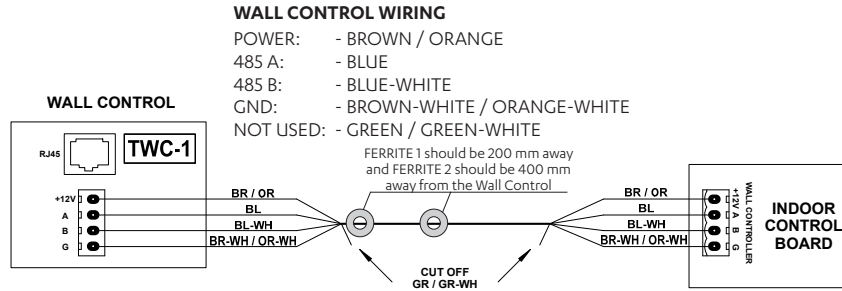

14.03. LM-RS-2 Optional Sensor Wiring Connections

REMOTE SENSOR WIRING

- PAIR 1: - BLUE / BLUE-WHITE
- PAIR 2: - ORANGE / ORANGE-WHITE
- PAIR 3: - GREEN / GREEN-WHITE
- PAIR 4: - BROWN / BROWN-WHITE

NOTE:

- PAIR 1 AND 2 USED FOR ILLUSTRATION PURPOSES ONLY.
- CUT OFF AND TERMINATE ANY UNUSED PAIRS TO ENSURE NO WIRING IS LEFT EXPOSED.

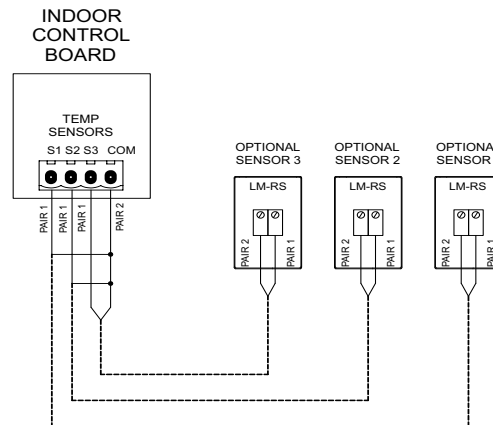

14.04. AERSS Optional Duct Sensor Wiring Connections

REMOTE SENSOR WIRING

- PAIR 1: - BLUE / BLUE-WHITE
- PAIR 2: - ORANGE / ORANGE-WHITE
- PAIR 3: - GREEN / GREEN-WHITE
- PAIR 4: - BROWN / BROWN-WHITE

NOTE:

- PAIR 1 AND 2 USED FOR ILLUSTRATION PURPOSES ONLY.
- CUT OFF AND TERMINATE ANY UNUSED PAIRS TO ENSURE NO WIRING IS LEFT EXPOSED.

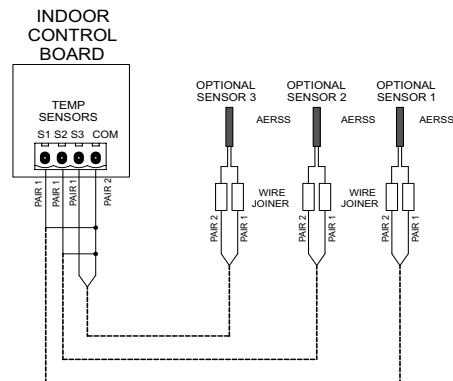

15. Configuring and Commissioning Setup

15.01. Menu and Navigation

diS (Display)	Display system's status and settings	
SEr (Service)	Service use only	
SEt (Settings)	cnFg	02.00 = Family*
		02.33 = Capacity*
	CtrS	Ct. 0 = 3rd Party
		Ct. 1 = Wall Control (default)
		Ct. 2 = Basic BMS
		Ct. 3 = Wall Control + Basic BMS
		Ct. 4 = Advanced BMS
	iduS	FP1 = IDU Fan Low PWM setting
		FP2 = IDU Fan Med PWM setting
		FP3 = IDU Fan High PWM setting
		Fr1 = IDU Fan Low RPM setting
		Fr2 = IDU Fan Med RPM setting
		Fr3 = IDU Fan High RPM setting
		FPd = IDU Fan Defrost PWM setting
		FPc = IDU Reduced Airflow PWM setting
		FiL = IDU Fan Filter Hours setting
		Econ = IDU Econ 0-10V Output setting
		FnSE = Indoor Fan Setting
	HtSt = HotStart On/Of	
	SoFt	no = Soft Start not enabled (default)
		YES = Soft Start enabled
	run	no = Indoor Fan and Compressor (default)
		YES = Compressor only
	odFs	Hi = High Start-up Speed (default)
		Lo = Low Start-up Speed

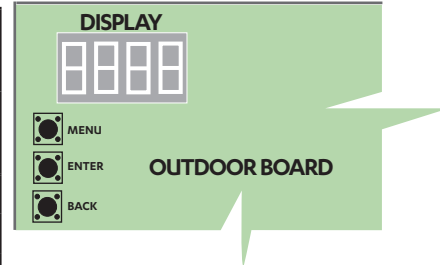

MENU

Scroll through the items at the same menu level. Increment the value being set.

ENTER

Go into the selected menu. Lock in selected value.

BACK

Go back to the parent menu. Press and hold to go back to main menu

* Family and Capacity are the representative values only and may vary depend on the model purchased as seen below table . **Do not change this setting.**

Model	PKV290T	PKV330T
Family	Capacity (kW)	
02	29	33

15.02. Configuring Compressor and Capacity (cnFg)

Configure the compressor type and capacity. The unit is factory configured. **Do not change this setting.**

15.03. Configuring Control Source (CtrS)

This commissioning is applicable for BMS and other Wall Control.

Configurable settings are as follows:

Third Party Control

The unit can be controlled by a non-ActronAir Wall Control. To do this, **CtrS** on the Outdoor Board has to be set to **Ct. 0**. For connection details, see the wiring diagram supplied with the outdoor unit.

Wall Control

ActronAir offers NEO and LC7-2, wall controls that can control the available features and maximise the function and operation of the air conditioner. To do this, **CtrS** on the Outdoor Board has to be set to **Ct. 1**.

Basic BMS

The unit can be connected to a network through a BMS card (ICUNO-MOD). This allows the unit to be operated in the same way the as the NEO and LC7-2 does. To do this, **CtrS** on the Outdoor Board has to be set to **Ct. 2**.

Wall Control + Basic BMS

The unit can be connected to a network (Basic BMS) and at the same time be controlled using the NEO or LC7-2 control. Priority will be given to the most recent command. To do this, **CtrS** on the Outdoor Board has to be set to **Ct. 3**.

Advanced BMS

The unit can be connected for system that requires customised functions not included in the existing software or logic in the Outdoor Board but still retaining the safety logic. To do this, **CtrS** on the Outdoor Board has to be set to **Ct. 4**.

15.04. Configuring Indoor Fan Setting (iduS)

The fan settings may be configured using three options: the Condenser CPU Board, NEO or LC7-2 Wall Control and Third Party Control.

NOTES

For Configuring Indoor FAN Setting (iduS) using wall control, please refer to respective wall controller installation and commissioning guide .

15.04.01. Indoor Fan Speed Commissioning

The Variable Capacity Commercial indoor fan operation is supplied as a single speed system, with speed settings model dependent. This speed is adjustable via outdoor board and the NEO or LC7-2 wall control (when connected). Refer to the fan curve and the fan table section of each models fan speed setting.

When either the NEO or LC7-2 wall control is connected, the option of a 3-speed indoor fan is available to be programmed. The default speed settings for each of the three speeds (High, Medium and Low) are also shown in the table below. See Option 2: via Outdoor Board. For more details see Option 1: via Wall Control (NEO or LC7-2).

NOTES

ActronAir do not recommend adjusting the RPM limit. Before making any changes, please contact ActronAir Technical Support on 1800 119 229.

Option 1: via LC7-2 Wall Control

Summary :

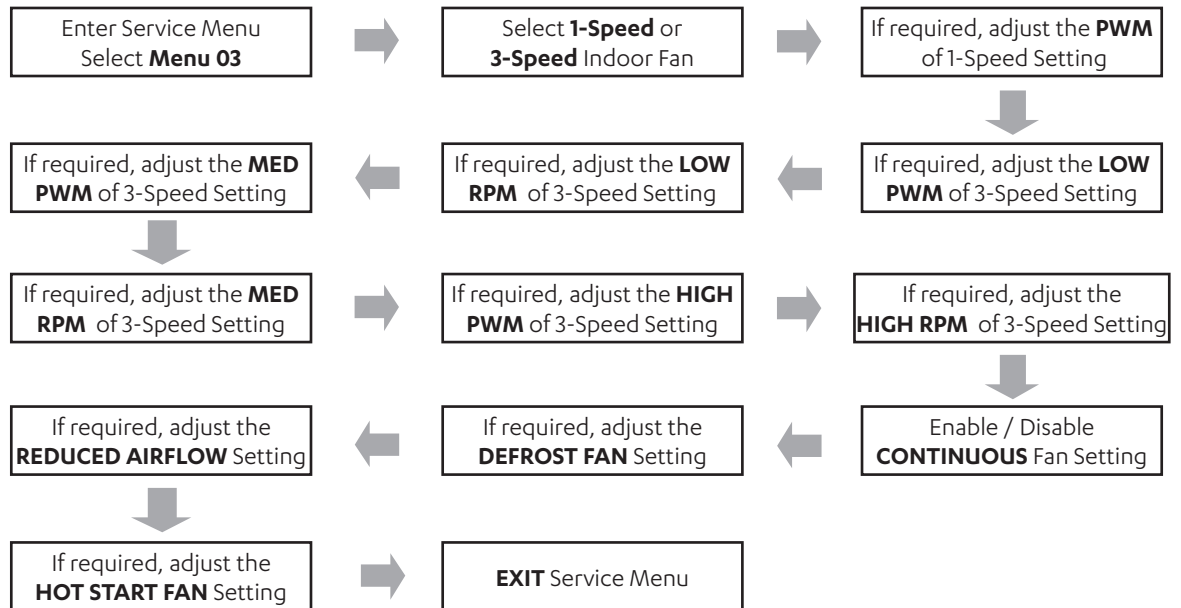

Procedure:

1. Press and hold the **REPEAT** and the **TIMER** buttons for 3 seconds then release to enter Service Menu.



2. Press the **▼** button to scroll through to Service Menu **03**.

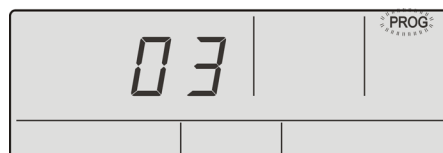

3. Press the **PROG** button to enter Service Menu **03**. Display will show the indoor fan speed selection.

NOTES

- 1 Speed indicated with number **1** and **MED** being illuminated.
- 3 Speed indicated with number **3** and **LOW**, **MED** and **HIGH** being illuminated.



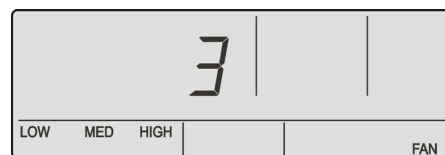

1- Speed Indoor Fan DEFAULT



3- Speed Indoor Fan



4. Press the **▲** or **▼** buttons to select 1 or 3-Speed indoor fan setting. Then press the **PROG** button to accept the selection.

5. Display will show the current **PWM** (speed) setting. Also displayed are **MED, FAN** and the **1** to signify that you are about to change the fan speed of 1-speed fan setting. Press the  or  buttons to adjust the single speed indoor fan PWM. Then press the **PROG** button to accept.

NOTES

It is not possible to skip this step even if 3-speed fan setting was selected. Either adjust the PWM or accept the default setting.





6. Display shows **LOW, MED, HIGH, 3** and **FAN**. With **LOW** blinking to signify current **LOW PWM** settings for 3-speed fan. Press the  or  buttons to adjust the PWM setting. Then press the **PROG** button to accept.

NOTE

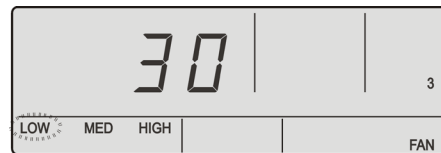
Default setting and adjustable range may vary depending on indoor models.



7. Next display will show the RPM setting for **LOW SPEED**. Press the  or  buttons to adjust the RPM setting. Then press the **PROG** button to accept.

NOTES

- The RPM numbers displayed should be multiplied by 10 to get the actual RPM setting. Example here is $110 \times 10 = 1100$ RPM.
- ActronAir do not recommend adjusting the RPM limit.
- Before making any changes, please contact ActronAir Technical Support on 1800 119 229.

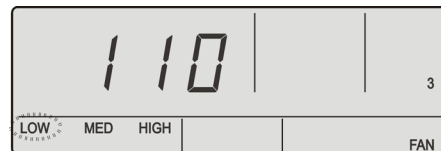

8. Repeat Steps 6-7 to set **MED** and then **HIGH** PWM and RPM limit settings.
9. Press **EXIT** button twice to leave the service menu.

Option 2: via Outdoor Board

The outdoor PCB has a 7 segment display, with 3 adjacent buttons, used for commissioning the indoor fan.

MENU → SEt → idUS →	PWM / RPM				Speed Setting	
	PKV290T-T	PKV330T-T	PKV290T-L/R	PKV330T-L/R	3 - Speed	1 - Speed
FP1	38	47	38	47	Low PWM	-
FP2	52	67	52	67	Med PWM	Med PWM
FP3	70	92	70	92	High PWM	-
Fr1	1200	1400	1200	1400	Low RPM	-
Fr2	1500	1750	1500	1750	Med RPM	Med RPM
Fr3	1800	2100	1800	2100	High RPM	-

Procedure:

- Using the **MENU** and the **ENTER** buttons, navigate to **SEt** (Settings) → **idUS** (Indoor Settings).
- If required, adjust and set **FP1** (Low PWM), **FP2** (Medium PWM) and **FP3** (High PWM).
- If required, adjust and set **Fr1** (Low RPM Limit), **Fr2** (Medium RPM Limit) and **Fr3** (High RPM Limit).

NOTE

FP1 (Low PWM), **FP2** (Medium PWM), **FP3** (High PWM) are adjustable settings within PWM high and low range limits. Refer to Section 15 for more details.

Option 3: Third Party Control

(0-10V Fan)

- On the Outdoor Board, set Control Source to Third Party. Using the **MENU** and the **ENTER** buttons, navigate to **SEt** (Settings) → **CtrS** (Control Source).
- Use the **MENU** button to navigate to **0** to select Third Party Control as the control source. Press the **ENTER** button to save the setting.
- On the Indoor Board, set the first dip switch to **ON** and also ensure dip switch is **ON**.



- Indoor Fan operation is now operational via 0-10V Third Party Control. For airflow and static pressure, see the fan curve and the fan table section for reference. Adjustable airflow range will vary from model to model.

(Fixed Speed)

- On the Outdoor Board, set Control Source to Third Party. Using the **MENU** and the **ENTER** buttons, navigate to **SEt** (Settings) → **CtrS** (Control Source).
- Use the **MENU** button to navigate to **0** to select Third Party Control as the control source. Press the **ENTER** button to save the setting.

NOTES

Adjustable airflow range will vary from model to model.
Medium Speed is the speed setting for 1-speed Fan.

- If medium speed setting (1-speed fan setting) is required to be changed, using the **MENU** and the **ENTER** buttons, navigate to **SEt** (Settings) → **idUS** (Indoor Settings) → **FP2** and **Fr2**.

- On the Indoor Board, ensure that all dip switches are set as per below image.

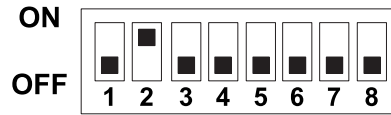

- Indoor Fan operation is now operational via Third Party Control (1-speed).

15.04.02. Defrost Fan Setting

This feature allows the installer to set the indoor fan speed (PWM) during defrost mode. By default, this is set to **0** PWM (Fan Off) to avoid cold air draft. However, in some applications, continuous air circulation maybe required even when the system went to defrost cycle.

The Defrost Indoor fan speed (PWM) is can be set through the NEO or LC7-2 wall control or Outdoor PCB. Procedures are shown below:

NOTE

To set Defrost Indoor fan speed (PWM) using wall controller please refer to respective wall control Installation and Commissioning Guide.

Option 1: LC7-2 Wall Control

- Press and hold the **REPEAT** and the **TIMER** buttons for 3 seconds then release to enter Service Menu. The display will show the Service Menu **01**.
- Press the or buttons to scroll to Service Menu **03**. Press the **PROG** button to enter the Service Menu **03**.
- Press the **PROG** button 9 x times to enter the Defrost Fan Settings.



- Press the or buttons to select the desired indoor fan PWM then press the **PROG** button to accept. The available range is from 10 to 100. OFF means that the indoor fan is OFF during the defrost cycle. The sample screen below shows the indoor fan to 20.

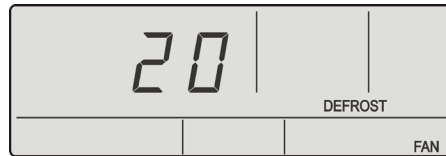

- Press the **EXIT** button twice to go back to the original status display.

Option 2: Outdoor Unit CPU Board



- Using the **MENU** and the **ENTER** buttons, navigate to **Set** (Settings) → **iduS** (Indoor Settings) → **FPd** (Defrost PWM)
- Keep pressing the **MENU** button to select the desired indoor fan speed PWM is shown. By default, the indoor fan PWM is set to **0** and it is adjustable from **0** to **100**.
Note: **0** means the indoor fan is off during the defrost cycle.
- Press the **ENTER** button to confirm the PWM settings.
- Press the **BACK** button three times to go back to the original status display.

15.04.03. Reduced Airflow



This feature allows the system to run at lower airflow down to 20% (below system normal application range) when the compressor is not active (cycle off). This feature is useful to reduce the indoor fan power consumption during system operation but maintain the essential air circulation in the room. Note that if Continuous Fan is enabled, it takes precedent over the Reduced Airflow.

The available airflow range of reduced airflow is presented on the fan table Reduced Airflow (Compressor Off) on the next pages. By default, this option is enabled and set to **20** PWM. To turn OFF or change the PWM value:

Option 1: LC7-2 Wall Control

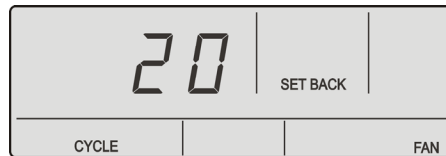
1. Press and hold the **REPEAT** and the **TIMER** buttons for 3 sec then release to enter Service Menu. The display will show the Service Menu **01**.
2. Press the   or  buttons to scroll to Service Menu **03**. Press the **PROG** button to enter the Service Menu **03**.
3. Press the **PROG** button 10 x times to enter the Reduced Airflow Settings.



4. Press the   or  buttons to select the desired indoor fan PWM then press the **PROG** button to accept. The available range is from **20** to **100**. OFF means that this function is disabled. The sample screen below shows the indoor fan is set to 30 PWM.

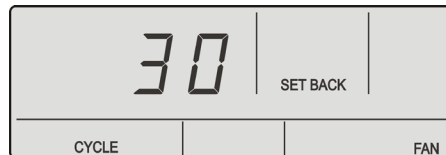

5. Press the **EXIT** button once to go back to the original status display.



Option 2: Outdoor Unit CPU Board

1. Using the **MENU** and the **ENTER** buttons, navigate to **Set** (Settings) → **iduS** (Indoor Settings) → **FpC** (Reduced PWM)
2. Keep pressing the **MENU** button to select the desired indoor fan speed PWM is shown. By default, the indoor fan PWM is set to **20** and it is adjustable from **20-100**.
Note: **0** means the Reduce Airflow Mode is disabled.
3. Press the **ENTER** button to confirm the PWM settings.
4. Press the **BACK** button three times to go back to the original status display.

15.04.04. Hot Start (Draft Reduction)

Hot Start is a feature only applicable in the heating cycle, that delays the indoor fans start-up. This allows the indoor coil to heat up before the indoor fan starts so an initial cold draft is prevented. When Hot Start is disabled the compressor and fan will start at approximately the same time.

LC7-2 Wall Control

1. Press and hold the **REPEAT** and **TIMER** buttons for 3 seconds then release to enter Service Menu. The display will show Service Menu **01**.
2. Press the   or  buttons to scroll to Service Menu **03**. Press the **PROG** button to enter the Service Menu **03**.

- Press the **PROG** button 11 x times to enter the Hot Start Settings.

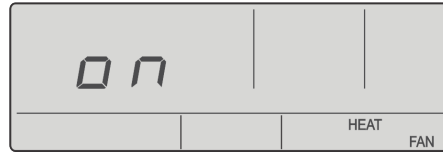

- Press the or buttons to enable/disable the hot start operation.

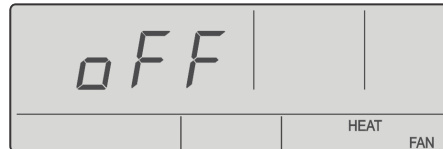

- Press the **PROG** button to accept the Hot Start setting.
- Press the **EXIT** button once to return to the Main Screen.

15.04.05. Air Filter Hours

This feature allows the installer to change the alarm time of Filter Notification. By default, the time before the filter alarm notification will appear is set to **200** hours. This is adjustable from **0** to **990** hrs.

Outdoor Unit CPU Board

- Using the **MENU** and the **ENTER** buttons, navigate to **Set** (Settings) → **iduS** (Indoor Settings) → **Fil** (Filter)
- Keep pressing the **MENU** button to select the desired filter notification alarm time is shown. By default, alarm time is set to **200** hrs and is adjustable from **0** to **9900**

Note: **0** means the Filter Alarm is disabled

- Press **ENTER** button to confirm the alarm time settings.
- Press the **BACK** button twice to go back to the original status display.

NOTE

Setting up “Air Filter Hours” is only available through Outdoor Unit CPU Board.



15.04.06. Outside Air Damper

This feature allows to set the optional outside air damper opening. The available output signal is from **0** to **10V**.

Option 1: LC7-2 Wall Control

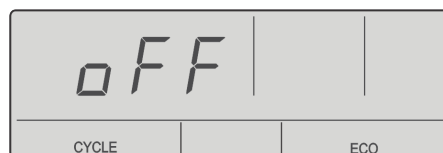
- Press and hold the **REPEAT** and the **TIMER** buttons for 3 sec then release to enter Service Menu. The display will show the Service Menu **01**.
- Press the or buttons to scroll to Service Menu **10**. Press the **PROG** button to enter the Service Menu **10**.
- Press the **PROG** button enter economy damper menu.



- Press the   or  buttons to enable economy damper, then press **PROG** to accept.



- Press the **PROG** button to enter economy damper setting.



- Press the   or  buttons to adjust the voltage output in 0.1V increments (**0 to 10V**), then press **PROG** to accept. Sample below shows 3.0V output.

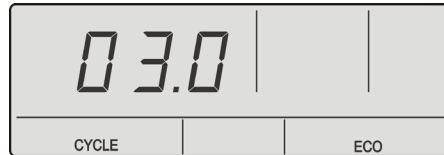

- Press the **EXIT** button once to go back to the original status display.



Option 2: Outdoor Unit CPU Board

- Using the **MENU** and the **ENTER** buttons, navigate to **SEt** (Settings) → **iduS** (Indoor Settings) → **Econ(0 to 10V Output)**
- Keep pressing the **MENU** button to select the desired opening (in voltage). By default, this is set to **0** (damper closed). Adjustable setting is from **0 to 10V**. (Note that in LED 7 segment display, 10.0V will show **100**.)
- Press **ENTER** to confirm the desired damper voltage. Press **BACK** button to leave the Menu.
- Press the **BACK** button three times to go back to the original status display.

15.04.07. Fan Continuous ON/OFF

This feature allows the user to access Continuous Fan Operation. Disabling this will hide the function from the wall control. By default, this function is enabled. To disable, follow the instruction below.

LC7-2 Wall Control

- Press and hold the **REPEAT** and the **TIMER** buttons for 3 sec then release to enter Service Menu. The display will show the Service Menu **01**.
- Press the   or  buttons to scroll to Service Menu **03**. Press the **PROG** button to enter the Service Menu **03**.
- Press the **PROG** button 7 x times to enter the Fan Continuous Settings.

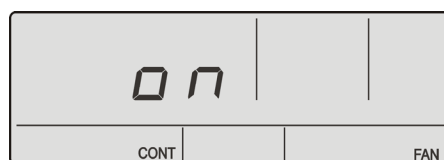

- Press the   or  buttons to select OFF. Then press the **PROG** button to accept.

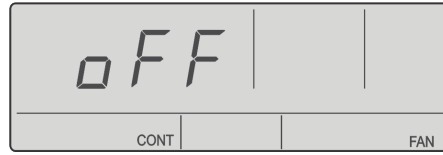

- Press the **BACK** button twice to go back to the original status display.

15.04.08. Compressor Soft Start Option

If an ActronAir compressor soft starter (sold separately) will be installed, it is necessary to enable this in OD Board Menu. However, if the soft starter is already pre-installed with the unit (“-Z Option”), no set up is necessary.

Procedure:

- Using the **MENU** and the **ENTER** buttons, navigate to **Set** (Settings) → **SoFt** (Soft Start Settings).
- If required, press **MENU** to navigate to **YES**. By default, this is set to **no**.

15.04.09. Run and Fault Indication Output

Run Output is configurable to indicate that the unit is running. There are two configurations in which this can be set

- Either the compressor or the Indoor Fan only is running
- Only Compressor is running.

By default, this is set to **no**, where indicator will turn on when either on ID Fan Only Operation mode or Compressor is running. To set up to compressor run indication only, in OD Board Menu follow below steps.

Procedure:

- Using the **MENU** and the **ENTER** buttons, navigate to **Set** (Settings) → **run** (Unit Operation Indicator Settings).
- If required, press **MENU** to navigate to **YES**.

16. Optional Output/Input Relay

16.01. Filter Indication Relay Output (CMI Board)

Allows for optional connection for Filter Indication Relay (10A/240V). Option to use either normally open or normally close relay.

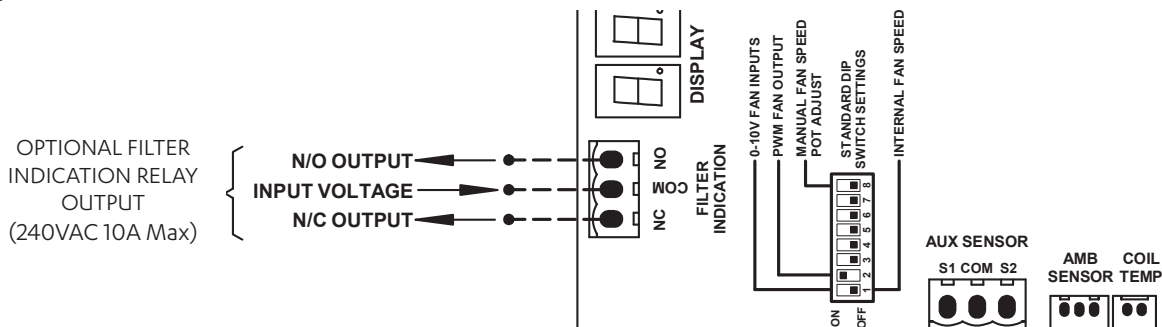

NOTE

To reset the alarm notification via Outdoor Board when using third party control, set the time again to clear/reset the filter alarm output.

16.02. Fan Run Indication Output (CMI Board)

Allows for optional Fan Run Indication (12VDC).

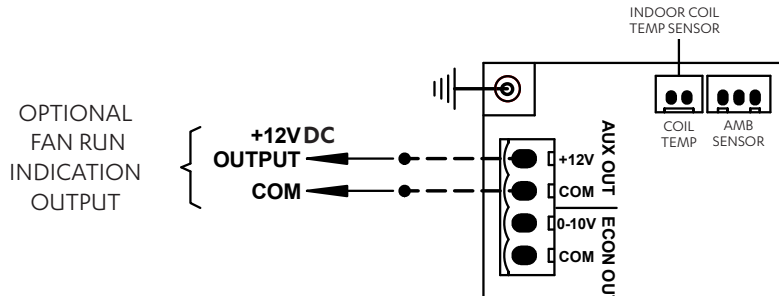

16.03. Optional Outside Air Damper Control Output (CMI Board)

This feature allows to set the optional outside air damper opening (0-10V). To set-up, see 15.04.06 (Outside Air Damper).

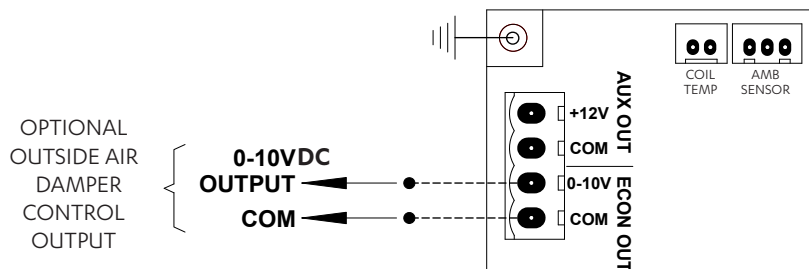

16.04. Third Party Control Input (CMI Board and/or Outdoor)

This option allows Fan, Compressor and Reversing Valve to be controlled by a Third Party Controller. There are two ways on how the Indoor Fan may be controlled, using 0-10V Analogue Input or Fixed Indoor Fan Speed.

To configure the Outdoor board and Indoor Board DIP switch setting, see 15.04.01 Option3 : Third Party Control.

NOTE

Demand Response Management (DRM) is not available if Third Party Control Option is used.

16.04.01. 0-10V Analogue Input for Compressor and Indoor Fan

Fan Connection (CMI Board)

On the Indoor Board, set the first dip switch to **ON**.

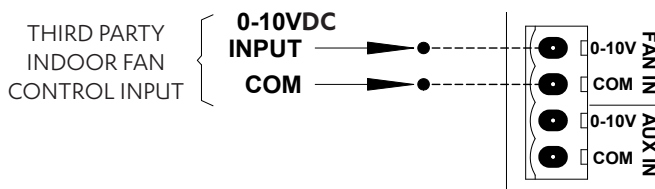

Input (DC)	Output	Fan Status
0.0V to 0.99V	0%	Off
1.0V to 1.49V	0 or 20%	Off or On
1.5V to 9.5V	20% to 100%	On
9.5V to 10V	100%	On

Compressor and Reversing Valve Connection (Outdoor Board)

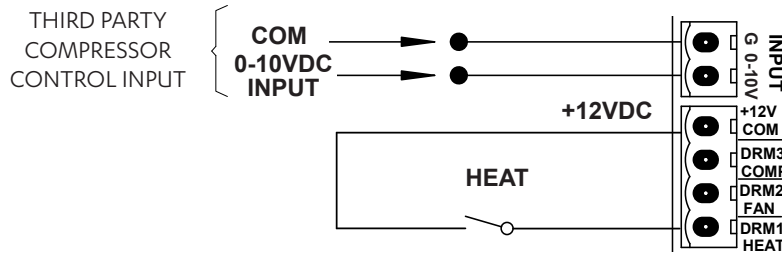

Input	Output	Compressor Status
0 - 0.99 V	0%	Off
1 - 1.49 V	0 or 20%	Off/On (hysteresis)
1.5 - 9.5 V	20% to 100%	On
9.5 - 10 V	100%	On

NOTE

- As the compressor turns ON and the Indoor fan signal is not available then indoor fan will start to run on medium PWM speed.
- If the compressor turn ON, during reduced fan operation, the controller will increase the fan speed to the “low PWM fan limit” if it is running less than the low PWM Limits.
- Indoor fan low and high PWM limits depends upon the model. Refer to Section 17 for more details.
- The Voltage can be linearly interpolated using the above table to determine the desired PWM or unit output.

16.04.02. 0-10V Analogue Input for Compressor with Fixed Indoor Fan Speed

This feature allows for the Indoor Fan to be controlled externally (ON/OFF only).

Fan, Compressor and Reversing Valve Connection (Outdoor Board)

On the indoor board ensure dip switch ONE is **OFF**.



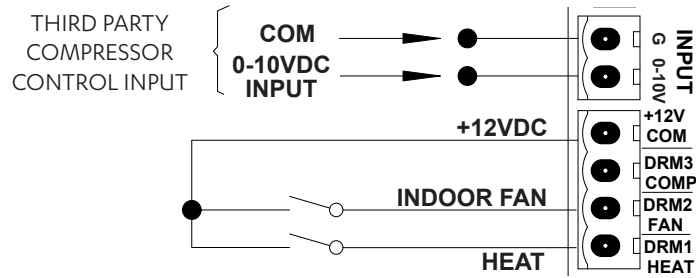

NOTE

- As the compressor turns ON and the Indoor fan signal is not available then indoor fan will start to run on medium PWM speed.
- Indoor fan operation when fan signal is available:
 - Compressor ON : Indoor fan will run on medium speed.
 - Compressor OFF : Indoor fan will run on reduce airflow operation.

16.04.03. Analogue Input for Fixed Compressor with Fixed Indoor Fan Speed

This feature allows for both Compressor and Indoor Fan to be controlled externally (ON/OFF only).

Fan, Compressor and Reversing Valve Connection (Outdoor Board)

On the indoor board ensure dip switch ONE is **OFF**.

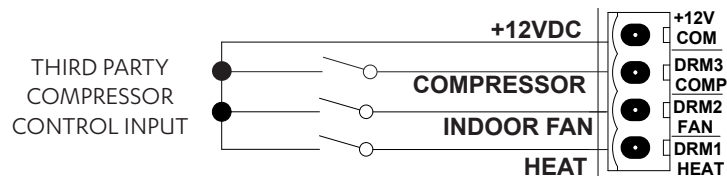
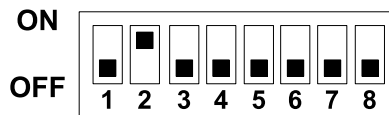

NOTES

- As the compressor turns ON and the Indoor fan signal is not available then indoor fan will start to run on medium PWM speed.
- Indoor fan operation when fan signal is available:
 - Compressor ON : Indoor fan will run on medium speed.
 - Compressor OFF : Indoor fan will run on reduce airflow operation.

16.05. Demand Response Management (Outdoor Board)

These products are compliant to AS/NZS 4755.3.1:2012

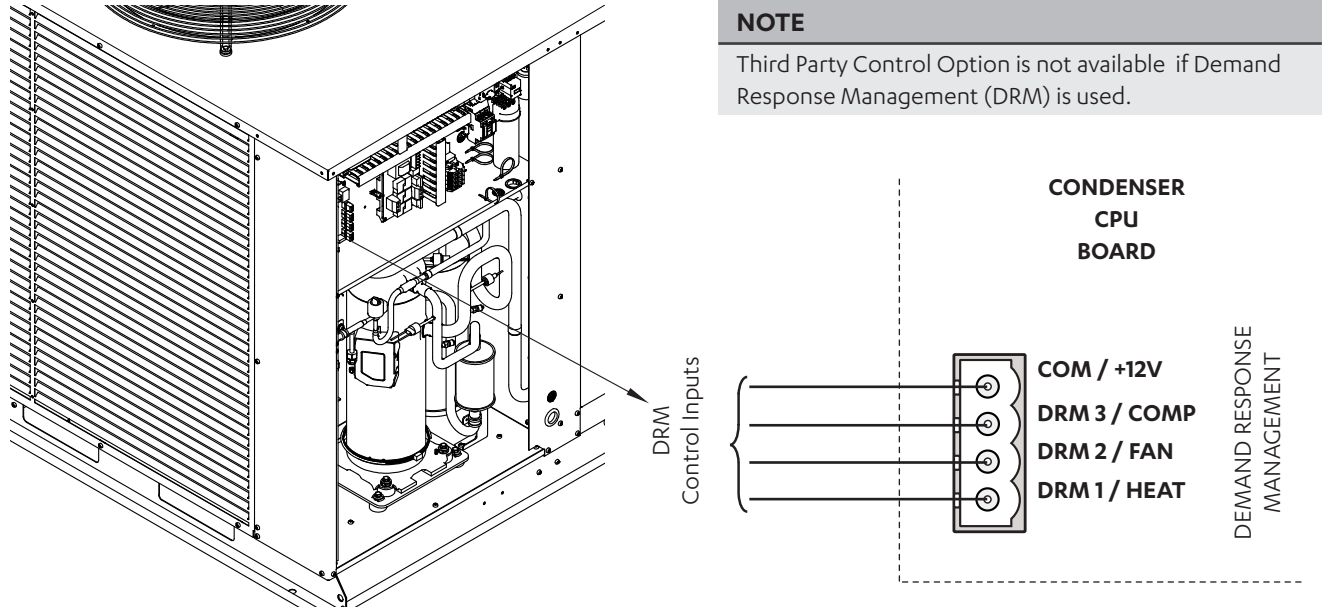

1. Thread and Route DRM input cables into the Unit (as per previous wiring installation procedure) .
2. Connect cables into terminals (as shown above and as per wiring diagram provided with the unit).

DEMAND RESPONSE ENABLING DEVICE (DRED) CIRCUIT DIAGRAM

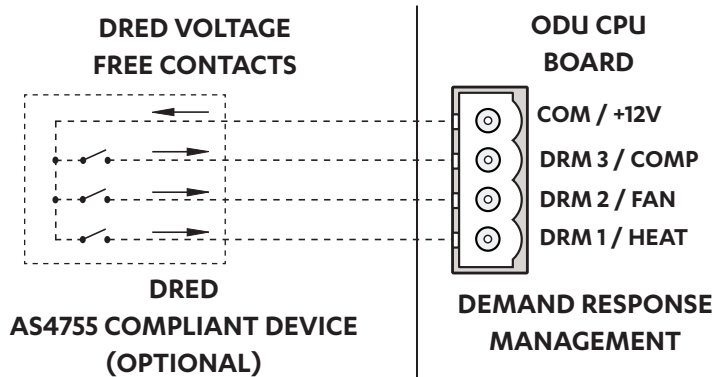

Demand Management Mode	Description Of Mode Allowable Range (%)	Operating Mode
DRM1	Compressor Off Mode	Compressor ONLY will cycle OFF and remain off for the entire Demand Response event. All other functions will operate as normal (i.e. Indoor Fan)
DRM2	Maximum 50% power use mode with 0 to <50% allowable power use range	Compressor 0 to <50% operation range for the total Demand Response event.
DRM3	Maximum 75% power use mode with 0 to <75% allowable power use range	Compressor 0 to <75% operation range for the total Demand Response event.

16.06. Run and Fault Indication Output (Outdoor Board)

To activate, the unit must be wired as illustrated below. See Section 15.04.09 for configuration. If required, a fault output connection terminal is also available to show any error/fault with the a/c system.

RUN/FAULT relay outputs (230VAC/5A MAX) connection

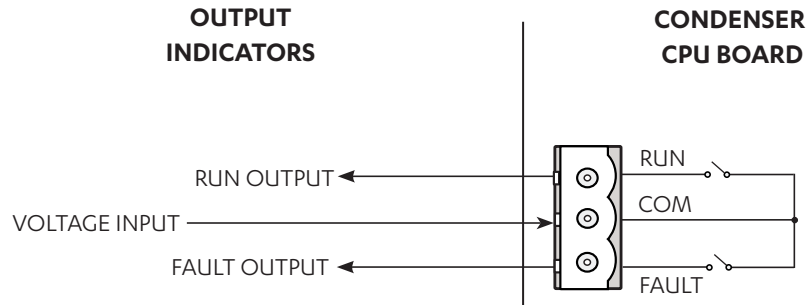

16.07. Remote ON/OFF

To activate, the unit must be wired as illustrated below. This will enable unit to be turned ON and OFF from the Outdoor board.

NOTE

The system must be operating in Wall Controller only (control mode 1) or BMS + Wall Controller (control mode 3) for this function to work.

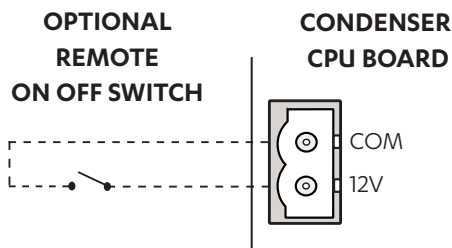

Turning the system On and Off by remote method	
Turning the system On	Status 1: The system is Off and the remote switch/relay has been left in the open position. 1. Close remote switch/relay. 2. System will start in approximately 1 minute.
	Status 2: The system is Off and the remote switch/relay has been left in the closed position. 1. Open remote switch/relay for a minimum of 5 seconds. 2. Close remote switch/relay. 3. System will start in approximately 30 seconds.
Turning the system Off	Status 3: The system is On and the remote switch/relay has been left in the closed position. 1. Open remote switch/relay. 2. System will turn Off in approximately 1 minute.
	Status 4: The system is On and the remote switch/relay has been left in the open position. 1. Close remote switch/relay for a minimum of 5 seconds. 2. Open remote switch/relay. 3. System will turn Off in approximately 30 seconds.

17. Indoor Fan Table And Fan Curve

17.01. PKV290T-T

APPLICATION RANGE (COMPRESSOR ON)												
AIRFLOW (l/s)	EXTERNAL STATIC PRESSURE (Pa)											
	50		100		150		200		250		300	
	% PWM	W	% PWM	W	% PWM	W	% PWM	W	% PWM	W	% PWM	W
1200	33	333	38	452	42	557	46	668	50	787	54	905
1250	36	380	40	480	44	585	48	698	52	821	56	950
1300	38	408	42	508	47	642	51	760	54	859	60	1003
1350	40	434	45	559	49	670	53	794	57	919	62	1069
1400	43	484	47	587	51	700	55	826	60	981	66	1107
1450	45	507	50	639	54	763	58	886	63	1037	71	1171
1500	48	559	52	671	57	822	61	943	66	1091	74	1225
1550	51	612	55	730	59	848	64	1000	69	1156	78	1292
1600	53	641	58	785	62	903	67	1060	72	1205	83	1355
1650	56	694	61	838	66	989	70	1121	75	1276	88	1426
1700	59	750	64	890	69	1048	73	1181	79	1344	93	1500
1750	62	797	67	945	72	1106	77	1271	83	1414	99	1551
1800	66	877	70	1000	75	1163	79	1316	88	1497		

REDUCED AIRFLOW * (COMPRESSOR OFF)													
AIRFLOW (l/s)	EXTERNAL STATIC PRESSURE (Pa)												
	50		100		150		200		250		300		
	% PWM	W	% PWM	W	% PWM	W	% PWM	W	% PWM	W	% PWM	W	
350											21	333	
400									20	295	23	372	
450									22	331	24	381	
500							21	291	23	340	26	408	
550							22	301	25	371	28	439	
600						20	242	23	310	27	406	30	480
650						22	274	25	341	28	418	32	521
700						23	282	26	351	30	452	34	555
750						24	290	28	385	31	460	35	561
800						26	320	30	416	33	493	37	592
850	20	179	24	260	28	351	31	423	35	524	39	621	
900	21	186	25	265	29	357	33	454	37	563	41	675	
950	23	212	27	294	31	386	35	483	40	622	43	710	
1000	25	235	29	321	33	414	38	542	42	656	45	744	
1050	27	261	31	347	35	440	40	574	44	689	48	804	
1100	29	286	33	374	37	472	42	606	46	719	50	831	
1150	31	310	35	398	39	502	44	637	48	754	52	874	

NOTES:

*Reduced fan airflow is the airflow during compressor OFF operation (optional feature)

W = Indoor Fan Power, Watts

PWM = Pulse Width Modulation Setting, % PWM (Adjustable through NEO / LC7-2 Control Interface or Outdoor Board)

Default Fan Speed Value at 100 Pa	
Speed	Default PWM
High PWM (%)	70 (adjustable)
Medium PWM (%)	52 (adjustable)
Low PWM (%)	38 (adjustable)

Indoor Fan PWM Limits	
High PWM (%)	99
Low PWM (%)	33

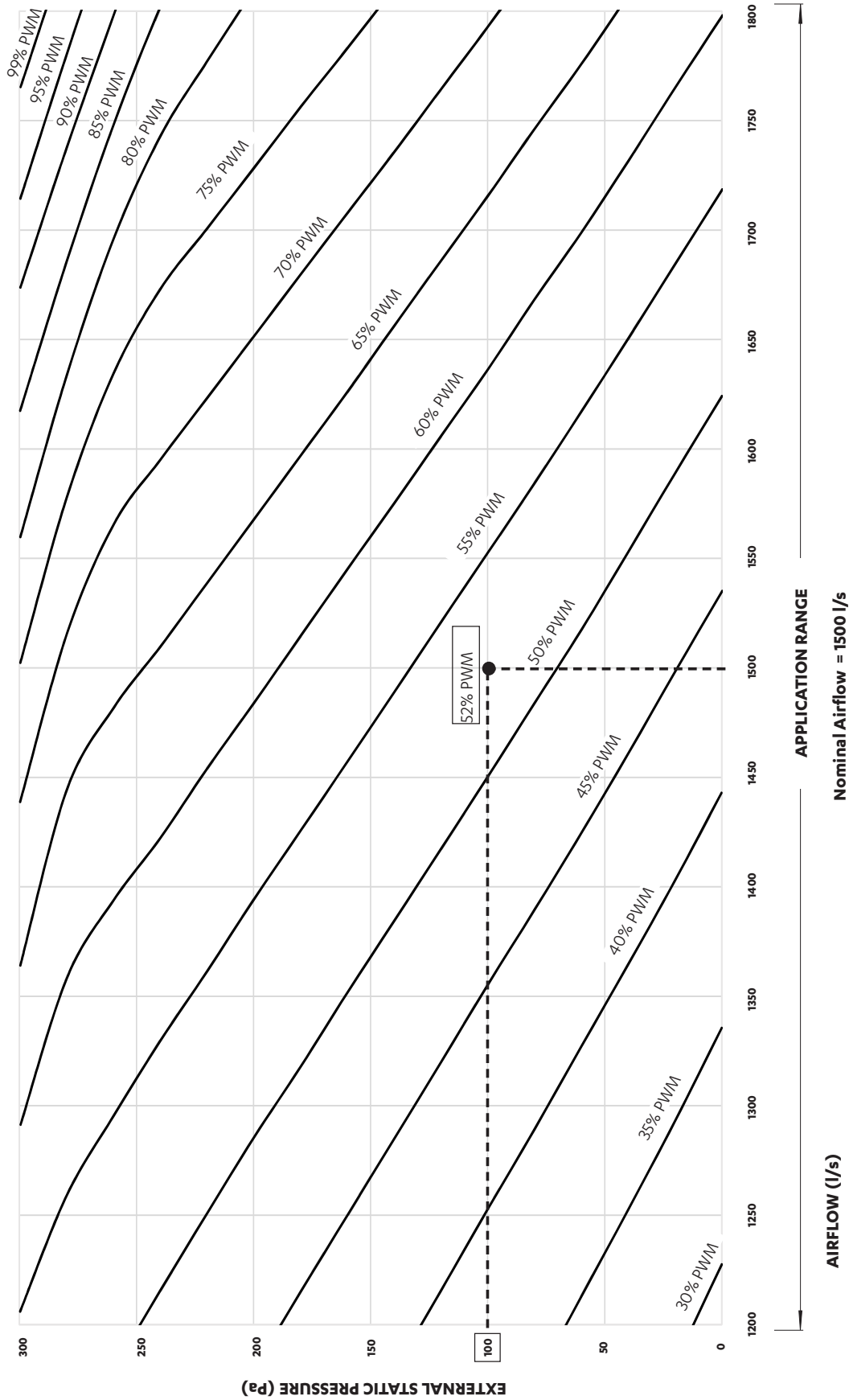

Notes:

1. Performance Fan Curve shown is at Dry Coil Condition.
2. Airflow should be reduced with respect to the moisture content in the air.
3. All data provided does not include filters. Please review filter manufacturer for application.
4. 2.5 m/s face velocity point will occur at 2150 l/s.

17.02. PKV330T-T

APPLICATION RANGE (COMPRESSOR ON)												
AIRFLOW (l/s)	EXTERNAL STATIC PRESSURE (Pa)											
	50		100		150		200		250		300	
	% PWM	W	% PWM	W	% PWM	W	% PWM	W	% PWM	W	% PWM	W
1400	42	463	47	589	51	707	54	835	59	961	71	1118
1450	45	509	49	630	53	755	58	896	62	1011	74	1172
1500	48	559	52	677	55	800	60	935	65	1075	78	1225
1550	50	601	54	725	59	853	63	992	68	1112	82	1288
1600	53	649	57	776	62	908	66	1045	70	1184	85	1354
1650	55	695	61	831	65	965	69	1104	74	1243	90	1419
1700	58	733	64	888	68	1026	72	1167	78	1316	95	1506
1750	62	803	67	947	71	1087	75	1235	83	1401	99	1564
1800	65	862	70	1006	74	1154	78	1308	88	1474	MOTOR / BLOWER LIMIT	
1850	69	926	73	1076	78	1228	82	1376	93	1557		
1900	72	988	77	1148	81	1305	86	1457	98	1639		
1950	75	1058	80	1223	85	1389	89	1533	MOTOR / BLOWER LIMIT			
2000	79	1134	84	1305	89	1468	94	1624				
2050	83	1206	88	1387	92	1556	99	1721				
2100	87	1304	92	1474	96	1638						

REDUCED AIRFLOW * (COMPRESSOR OFF)																
AIRFLOW (l/s)	EXTERNAL STATIC PRESSURE (Pa)															
	50		100		150		200		250		300					
	% PWM	W	% PWM	W	% PWM	W	% PWM	W	% PWM	W	% PWM	W				
350	MOTOR / BLOWER LIMIT										12	174				
400											20	289	23	347		
450											22	322	25	393		
500											21	287	23	337	26	403
550											22	297	25	370	28	431
600	MOTOR / BLOWER LIMIT		20	236	23	307	26	378	30	476						
650			21	247	25	338	28	415	32	499						
700	MOTOR / BLOWER LIMIT		23	278	26	347	30	446	34	532						
750			21	217	24	286	28	380	31	454	35	561				
800	MOTOR / BLOWER LIMIT		22	230	26	316	30	410	33	492	37	580				
850			20	176	24	257	27	323	31	418	35	524	39	615		
900	21	183	25	263	29	352	33	453	37	561	42	665				
950	23	209	27	291	31	383	35	486	38	568	44	714				
1000	25	232	29	318	33	415	36	492	40	600	47	763				
1050	27	259	31	345	34	420	38	524	43	669	50	804				
1100	29	282	33	375	36	449	41	585	46	727	52	845				
1150	31	308	35	402	39	503	43	618	48	764	55	887				
1200	33	335	37	431	41	536	46	678	50	794	57	929				
1250	35	361	39	457	44	594	48	708	52	832	60	969				
1300	37	387	42	513	46	623	50	737	54	888	64	1024				
1350	40	426	44	541	48	659	52	780	56	918	67	1065				

NOTES:

*Reduced fan airflow is the airflow during compressor OFF operation (optional feature)

W = Indoor Fan Power, Watts

PWM = Pulse Width Modulation Setting, % PWM (Adjustable through NEO / LC7-2 Control Interface or Outdoor Board)

Default Fan Speed Value at 100 Pa	
Speed	Default PWM
High PWM (%)	92 (adjustable)
Medium PWM (%)	67 (adjustable)
Low PWM (%)	47 (adjustable)

Indoor Fan PWM Limits	
High PWM (%)	99
Low PWM (%)	42

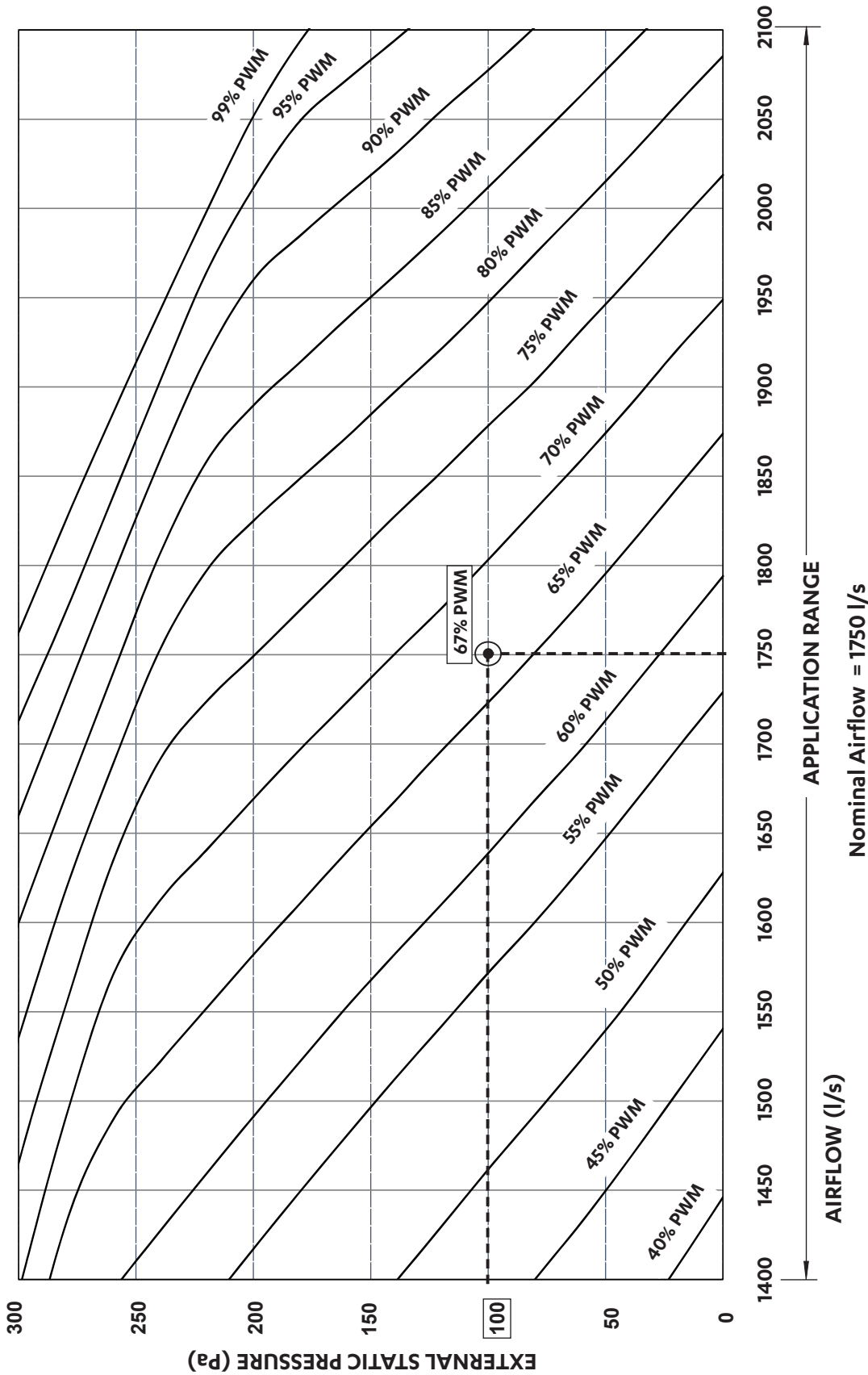

Notes:

1. Performance Fan Curve shown is at Dry Coil Condition.
2. Airflow should be reduced with respect to the moisture content in the air.
3. All data provided does not include filters. Please review filter manufacturer for application.
4. 2.5 m/s face velocity point will occur at 2150 l/s.

17.03. PKV290T-L/R

APPLICATION RANGE (COMPRESSOR ON)												
AIRFLOW (l/s)	EXTERNAL STATIC PRESSURE (Pa)											
	50		100		150		200		250		300	
	% PWM	W	% PWM	W	% PWM	W	% PWM	W	% PWM	W	% PWM	W
1200	34	327	38	417	42	519	46	631	50	741	55	884
1250	36	350	41	470	44	551	48	658	53	799	57	914
1300	39	398	43	499	47	603	51	710	55	823	59	959
1350	41	423	45	526	49	627	54	763	58	892	62	1004
1400	43	449	48	574	52	679	56	793	60	922	64	1039
1450	46	498	51	622	55	728	59	856	63	983	67	1102
1500	49	543	54	671	58	792	62	915	66	1041	70	1178
1550	52	589	56	697	60	821	65	970	69	1106	73	1221
1600	55	635	59	756	63	874	67	1000	71	1136	76	1290
1650	58	693	62	810	66	930	70	1063	75	1231	78	1317
1700	61	745	65	860	70	1020	74	1152	78	1293	84	1438
1750	64	795	68	916	73	1076	77	1211	81	1348	88	1505
1800	67	847	72	1003	76	1133	81	1305	85	1454	93	1582

REDUCED AIRFLOW (COMPRESSOR OFF)												
AIRFLOW (l/s)	EXTERNAL STATIC PRESSURE (Pa)											
	50		100		150		200		250		300	
	% PWM	W	% PWM	W	% PWM	W	% PWM	W	% PWM	W	% PWM	W
350	MOTOR / BLOWER LIMIT										21	266
400											23	297
450											24	366
500											26	390
550											28	431
600											29	437
650											31	466
700											33	501
750											35	532
800											37	565
850	20	164	25	254	29	342	33	438	36	516	39	598
900	22	188	26	261	31	370	35	469	38	548	42	655
950	24	209	28	287	32	375	36	473	40	579	44	699
1000	26	232	30	311	34	403	38	505	42	615	46	724
1050	28	256	32	340	36	431	40	533	44	650	48	766
1100	30	279	34	366	38	460	42	567	46	683	51	823
1150	32	304	36	391	40	486	44	600	48	714	53	853

NOTES:

*Reduced fan airflow is the airflow during compressor OFF operation (optional feature)

W = Indoor Fan Power, Watts

PWM = Pulse Width Modulation Setting, % PWM (Adjustable through NEO / LC7-2 Control Interface or Outdoor Board)

Default Fan Speed Value	
Speed	Default PWM
High PWM (%)	70 (adjustable)
Medium PWM (%)	52 (adjustable)
Low PWM (%)	38 (adjustable)

Indoor Fan PWM Limits	
High PWM (%)	99
Low PWM (%)	33

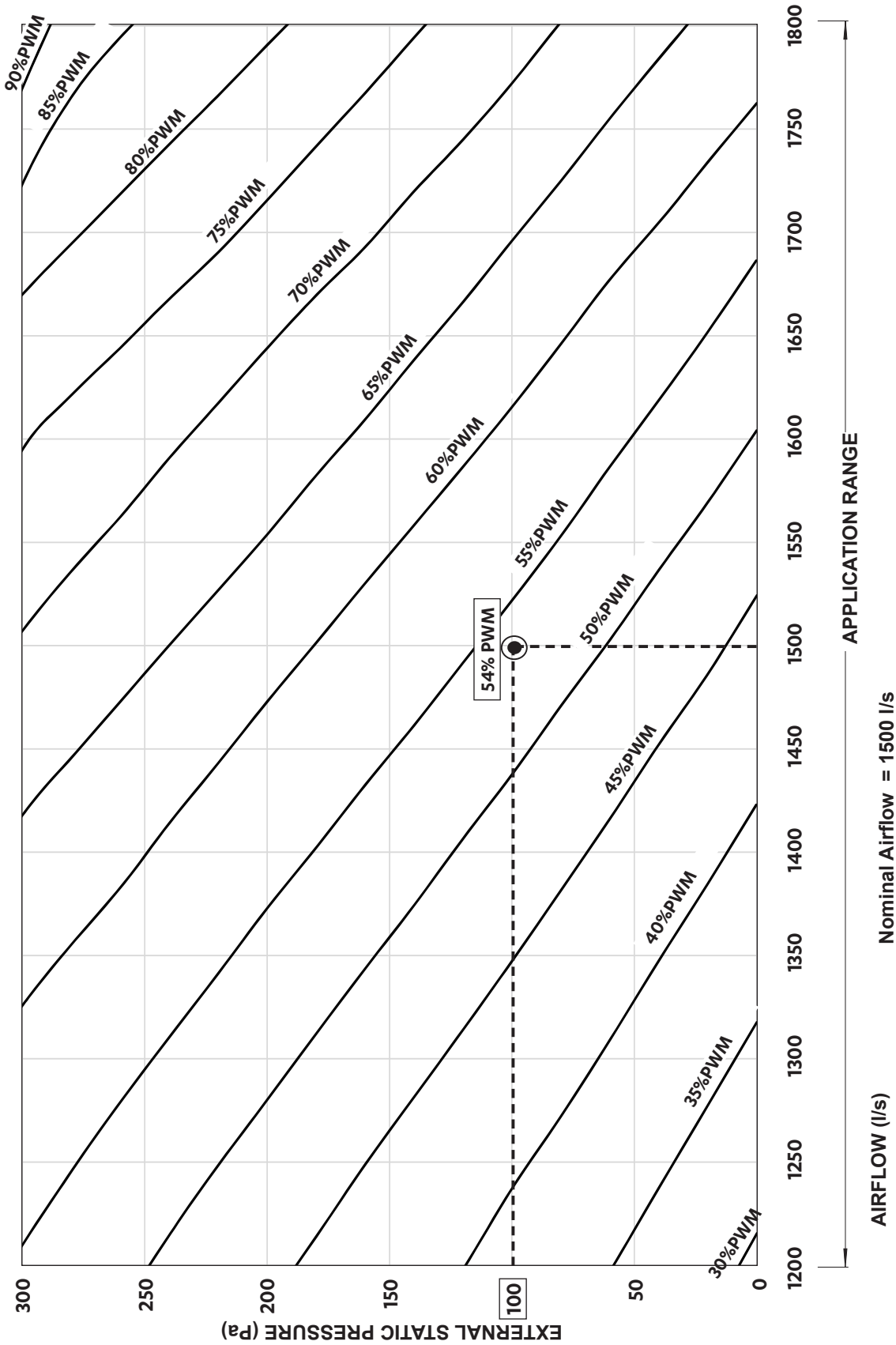

Notes:

1. Performance Fan Curve shown is at Dry Coil Condition.
2. Airflow should be reduced with respect to the moisture content in the air.
3. All data provided does not include filters. Please review filter manufacturer for application.
4. 2.5 m/s face velocity point will occur at 2100 l/s.

17.04. PKV330T-L/R

APPLICATION RANGE (COMPRESSOR ON)												
AIRFLOW (l/s)	EXTERNAL STATIC PRESSURE (Pa)											
	50		100		150		200		250		300	
	% PWM	W	% PWM	W	% PWM	W	% PWM	W	% PWM	W	% PWM	W
1400	46	536	50	640	55	780	58	876	62	1002	71	1168
1450	49	587	53	694	57	810	61	939	65	1081	76	1239
1500	52	637	56	747	60	867	64	1005	68	1128	79	1294
1550	55	686	59	801	63	933	67	1068	71	1190	83	1355
1600	58	739	62	862	66	995	70	1125	74	1257	89	1430
1650	61	792	65	925	69	1051	73	1188	78	1330	93	1504
1700	64	855	68	980	73	1143	77	1275	83	1420	97	1579
1750	67	912	72	1067	76	1198	81	1357	87	1494		
1800	71	993	75	1122	80	1,282	84	1431	93	1583		
1850	74	1047	79	1205	83	1349	88	1513	99	1682		
1900	78	1129	82	1265	87	1450	93	1619				
1950	82	1218	86	1365	91	1542	97	1703				
2000	84	1247	90	1458	95	1634						
2050	89	1373	94	1544								
2100	93	1457	99	1660								

MOTOR / BLOWER LIMIT

REDUCED AIRFLOW (COMPRESSOR OFF)													
AIRFLOW (l/s)	EXTERNAL STATIC PRESSURE (Pa)												
	50		100		150		200		250		300		
	% PWM	W	% PWM	W	% PWM	W	% PWM	W	% PWM	W	% PWM	W	
350											21	326	
400									20	293	22	338	
450									21	302	24	379	
500							20	261	23	335	26	406	
550							22	295	25	365	27	420	
600						20	235	24	324	26	373	29	454
650						22	265	25	329	28	406	31	481
700						24	293	27	363	30	435	33	517
750						25	299	29	391	32	468	35	549
800						27	329	31	423	34	501	37	584
850	21	192	25	268	29	357	33	454	36	533	39	619	
900	23	216	27	297	31	386	35	482	38	567	42	675	
950	25	238	29	323	33	414	37	516	41	628	44	712	
1000	27	264	31	349	36	467	39	548	43	659	47	762	
1050	29	288	33	374	38	498	41	580	45	690	50	818	
1100	31	312	36	424	40	529	44	638	48	742	53	862	
1150	34	357	38	454	42	559	46	666	51	798	55	914	
1200	36	383	40	482	44	588	49	719	53	841	58	946	
1250	38	411	42	511	47	641	51	751	55	874	60	983	
1300	41	461	45	562	49	668	54	813	57	903	64	1049	
1350	43	487	48	615	52	725	56	844	59	944	67	1103	

NOTES:

*Reduced fan airflow is the airflow during compressor OFF operation (optional feature)

W = Indoor Fan Power, Watts

PWM = Pulse Width Modulation Setting, % PWM (Adjustable through NEO / LC7-2 Control Interface or Outdoor Board)

Default Fan Speed Value	
Speed	Default PWM
High PWM (%)	92 (adjustable)
Medium PWM (%)	67 (adjustable)
Low PWM (%)	47 (adjustable)

Indoor Fan PWM Limits	
High PWM (%)	99
Low PWM (%)	42

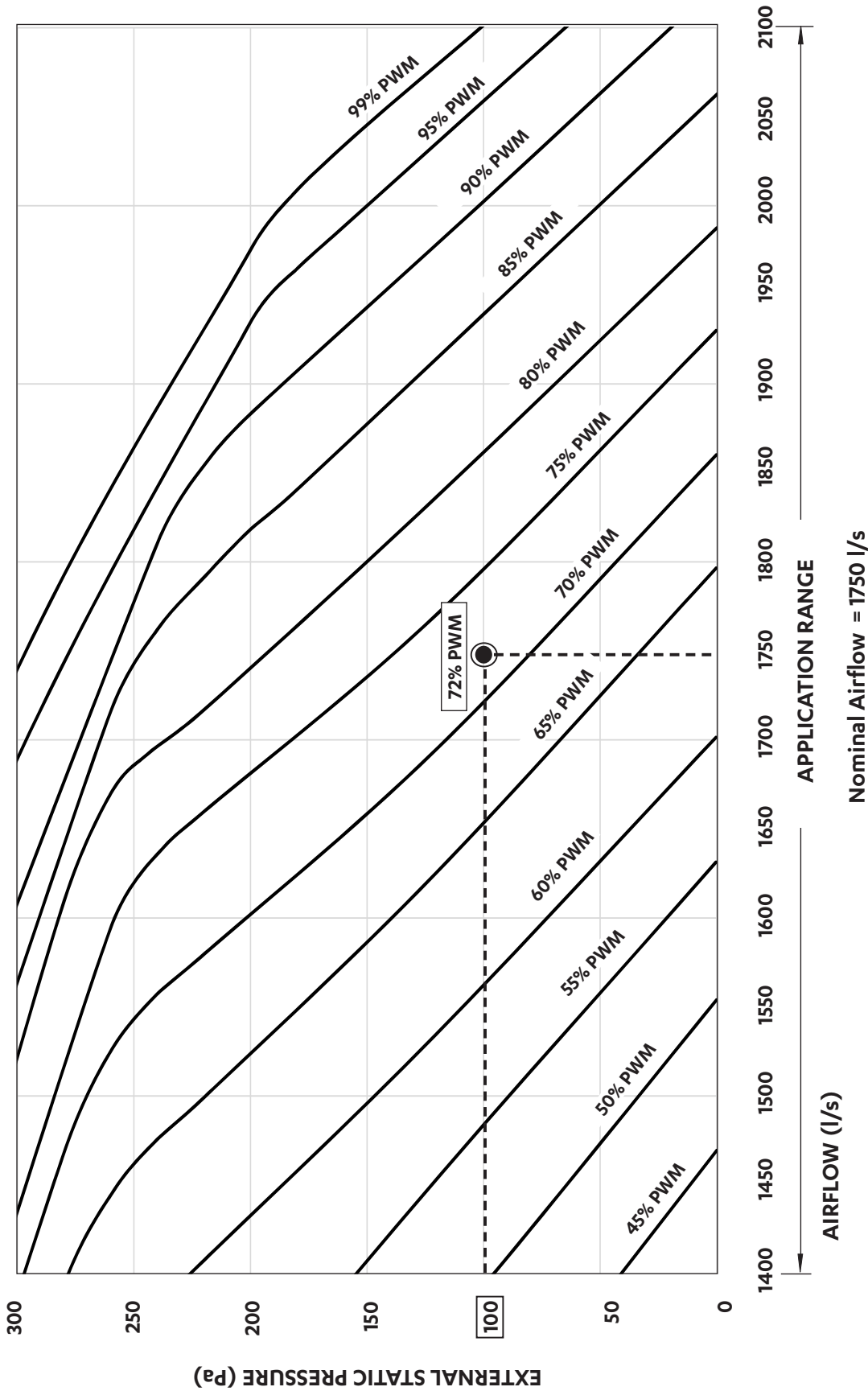

Notes:

1. Performance Fan Curve shown is at Dry Coil Condition.
2. Airflow should be reduced with respect to the moisture content in the air.
3. All data provided does not include filters. Please review filter manufacturer for application.
4. 2.5 m/s face velocity point will occur at 2100 l/s.

18. Refrigerant Charging

- The units detailed on this guide are factory charged with R-410A refrigerant. Should there be need to add or remove refrigerant, it is recommended to follow the charging method explained below.
- Never allow R-410A refrigerant to vent into the atmosphere. It is an offence to release refrigerant in Australia. Always reclaim refrigerant using equipment and container dedicated for R-410A system use only.
- All work must be carried out in accordance with Australia and New Zealand refrigerant handling code of practice.
- Only qualified technicians are allowed to perform any work described in this guide and specifically work related to addition or removal of refrigerant.
- R-410A refrigerant must always be charged in liquid state.
- Only during the compressor running condition the system can be charged through the suction service port on the compressor suction line.
- Changes in refrigerant charge must be noted to a label that is fixed to the unit for future reference.

CAUTION

The system of this unit operates with POE oil that rapidly absorbs moisture. The maximum time any system can be opened to atmosphere is 15 minutes.

REFRIGERANT CHARGE DETAILS (R-410A)	
Model	Refrigerant Charge (g)
PKV290T-T	8,500
PKV330T-T	10,800
PKV290T-L/R	9,000
PKV330T-L/R	12,600

SUBCOOLING AND SUPERHEAT CHARGING METHOD

Parameters:

LLT = Liquid Line Temperature

SLT = Suction Line Temperature

SCT = Saturated Condensing Temperature

SST = Saturated Suction Temperature

Cooling and Heating Operation:

Adjust the refrigerant charge to obtain the correct superheat and subcooling for optimal performance as follows:

1. Ensure that air filters are fitted and total system airflow is achieved. (Air filters are not supplied with the unit, it is the responsibility of the installing contractor to provide and fit adequate return air and outside air filters).
2. Connect service gauges to the schrader valves.
3. Start the unit in cool mode ensuring that compressors are in 100% operation before taking service gauges reading. Allow the system to stabilize for next 15-30 minutes before recording.

Record the discharge pressure, suction pressure, liquid line temperature and suction line temperature for all of the refrigeration circuits:

Discharge Pressure:	kPa
Liquid Line Temperature (LLT):	°C
Suction Pressure:	kPa
Suction Line Temperature (SLT)	°C

NOTES

- Accurate pressure and temperature measuring tools should be used to achieve satisfactory results.
- The sensor of a thermocouple must be in good contact with the area being measured and must be insulated in order to obtain correct reading.

Checking for Subcooling:

1. From the R-410A Pressure/Temperature Chart record the corresponding Saturated Condensing Temperature (**SCT**) at the given discharge pressure.
2. Calculate the system subcooling using the formula below:

$$\text{Subcooling} = \text{SCT} - \text{LLT}$$

3. If subcooling is within the range (see charging table below), there is no need to add/remove refrigerant.
 - If subcooling is lower than minimum, the system is undercharged, it is necessary to add refrigerant.
 - If subcooling is higher than maximum, the system is over charged, It is necessary to remove the refrigerant.

Allow the systems to stabilise (15-30 mins) and repeat the step 1-3 until subcooling falls within the range specified in the table below.

Checking for Superheat:

Maintaining the correct superheat is important for ensuring the evaporator is achieving maximum capacity and avoiding excessive liquid refrigerant returning to the compressor.

1. From the R-410A Pressure/Temperature Chart record the corresponding Saturated Suction Temperature (**SST**) at the given suction pressure.
2. Calculate the system superheat using the formula below:

$$\text{Superheat} = \text{SLT} - \text{SST}$$

3. If superheat is within the range (see charging table below), there is no need to add/remove refrigerant.
 - If superheat is lower than minimum, it means that liquid refrigerant may be returning to compressor. It is necessary to remove refrigerant or check EEV settings (EEV used in ESP models only).
 - If superheat is higher than maximum, it means that refrigeration capability of evaporator is not fully maximised. It is necessary to add refrigerant charge or check EEV settings (EEV used in ESP models only).

Allow the systems to stabilise (15-30 mins) and repeat the step 1-3 until superheat falls within the range specified in the table below.

SUBCOOLING / SUPERHEAT				
Models	COOLING		HEATING	
	Subcooling	Superheat	Subcooling	Superheat
PKV290T-T	7 ±1	3 ±1	12 ±1	2 ±1
PKV330T-T	8 ±1	4 ±1	13 ±1	6 ±1
PKV290T-L/R	8 ±1	4 ±1	14 ±1	2 ±1
PKV330T-L/R	9 ±1	7 ±1	14 ±1	1 ±1

NOTE

The above subcooling and superheat recommendations are based on the following rated conditions:

- Cooling: 35°C DB outdoor, air entering indoor at 27°C DB / 19°C WB.
- Heating: 7°C DB / 6°C WB outdoor, air entering indoor at 20°C DB Nominal indoor airflow.

R-410A PRESSURE / TEMPERATURE CHART

Temp °C	Pressure kPa	Temp °C	Pressure kPa	Temp °C	Pressure kPa	Temp °C	Pressure kPa
-60	-34.4	-28	194.9	4	805.9	36	2090.7
-59	-30.7	-27	206.9	5	834.1	37	2145.5
-58	-26.8	-26	219.2	6	862.9	38	2201.3
-57	-22.8	-25	231.9	7	892.6	39	2258.2
-56	-18.6	-24	245.1	8	922.8	40	2316.1
-55	-14.2	-23	258.7	9	953.8	41	2375.1
-54	-9.6	-22	272.6	10	985.4	42	2435.1
-53	-4.8	-21	286.9	11	1017.8	43	2496.2
-52	0.8	-20	301.7	12	1050.9	44	2558.5
-51	5.3	-19	316.9	13	1084.7	45	2621.8
-50	10.7	-18	332.6	14	1119.2	46	2686.2
-49	16.3	-17	348.7	15	1154.6	47	2751.8
-48	22.2	-16	365.2	16	1190.7	48	2818.5
-47	28.2	-15	382.3	17	1227.5	49	2886.4
-46	34.0	-14	399.7	18	1265.2	50	2955.5
-45	40.9	-13	417.7	19	1303.6	51	3025.7
-44	47.8	-12	436.2	20	1342.9	52	3097.2
-43	54.8	-11	455.1	21	1382.9	53	3169.9
-42	62.1	-10	474.6	22	1423.9	54	3243.7
-41	69.6	-9	494.6	23	1465.7	55	3318.9
-40	77.4	-8	515.1	24	1508.3	56	3395.2
-39	85.5	-7	536.2	25	1551.8	57	3472.9
-38	93.9	-6	557.8	26	1596.2	58	3551.8
-37	102.5	-5	579.8	27	1641.4	59	3631.9
-36	111.5	-4	602.6	28	1687.6	60	3713.5
-35	120.8	-3	625.9	29	1734.6	61	3796.3
-34	130.4	-2	649.8	30	1782.6	62	3880.5
-33	140.3	-1	674.3	31	1831.6	63	3965.9
-32	150.5	0	699.4	32	1881.5	64	4052.8
-31	161.1	1	724.9	33	1932.3	65	4140.9
-30	171.9	2	751.3	34	1984.1	66	4230.6
-29	183.3	3	778.3	35	2036.9	67	4321.5

19. Maintenance Procedures

This section describes the procedure that must be performed as a part of normal maintenance program. Regular servicing of equipment by licensed technician is highly recommended. Regular servicing of your unit helps in maintaining its optimum performance and reliability. **The checklist and service periods provided on this manual are guides only, as some sites may require more frequent servicing.**

Always disconnect electrical power to the unit before performing maintenance. It is always a safe practice to observe all safety warnings and cautions when conducting maintenance tasks.

DANGER

Live Electrical Connections !

It may be necessary to work with live electrical components on certain maintenance tasks. Only qualified technicians are allowed to perform these tasks.

WARNING

Hazardous Voltage !

Always make sure that all power supply, including remote controls, are disconnected before performing maintenance. Observe proper LOCK-OUT / TAG-OUT procedures to ensure that power cannot be inadvertently energised. Failure to disconnect power before maintenance procedures can result in serious injury and/or death.

Annual Maintenance Checklists

- Perform general maintenance inspections.
- Perform scheduled start-up checks.
- Leak test refrigerant circuits.
- Inspect contacts of all contactors and relays. Replace all worn contacts as required.
- Inspect, clean and tighten all electrical connections.
- Check fans for balanced operation. Make sure that there are no loose screws / bolts, no fan blades interference and no damage to the fans and guards.
- Inspect the air filters, clean or replace as required.
- Clean and repaint any corroded panel section.
- Ensure no blockage of airflow through variable speed drive and drive fan is operating correctly.

Cleaning the Condenser Coils

Clean the coils at least once a year or more frequently if the unit is located in a dusty and dirty environment, in order to maintain your system's proper operating performance. High discharge pressures are good indication that the coils need cleaning. When using detergent or solvents to clean the coils, follow the manufacturer's instructions to avoid potential damage to the coils and to the unit.

To clean the refrigerant coils, use a soft brush and water spray, such as garden hose or pressure washer with low pressure nozzle.

CAUTION

Do Not Use High Alkaline Detergent !

When using detergent for coil cleaning, ensure that the alkaline level is no higher than 8.5, which can cause corrosion damage to the coils.

No Water into the Drive!

Ensure consideration is given to the possibility of water entering the electrical compartments during cleaning of the condenser coil.

Coil Cleaning Procedures

- Disconnect power to the unit.
- Remove the louvered panels from the unit to gain access to the air inlet side of the coils.
- Use a soft brush to remove loose dirt and debris from both sides of the coils.
- Straighten bent coil fins with fin comb.
- Prepare the detergent solutions according to the manufacturer's instructions.
- Spray solution at a 90° angle to the coils, keeping a minimum nozzle spray angle of 15°, with at least a 1800mm distance from the coils and 600 psi pressure.
- Spray leaving air side of the coils first then the air inlet side. Allow the solution to stand on the coils for five minutes.
- Rinse both sides of the coils with cool clean water.
- Inspect the coils, if they are still dirty, repeat the cleaning procedure.
- Clean and wipe dry the outer and inner sides of the unit, the refrigerating parts and other components.
- Ensure that the condensate drain lines are not blocked.
- Reinstall all unit panels, covers and guards.
- Restore electrical power to the unit.



Be Careful Not to Spray Water into the Electrical Components !

20. Maintenance Frequency Checklist

Electrical											
Parts	Service Period					Detail of Service Check	Service Methods				
	1 Mth	3 Mth	6 Mth	1 Yr	2 Yrs			3 Yrs	4 Yrs	5 Yrs	
Printed Circuit Boards				✓						Visual Inspection	Tighten Terminals as necessary on printed circuit boards
Electrical Connections				✓						Check all electrical terminals, mains, communications, etc	Re-tighten if loose.
Magnetic Contactor				✓						Check for loose terminal connections.	Tighten electrical terminals. Remove any dust.

Indoor Section											
Parts	Service Period					Detail of Service Check	Service Methods				
	1 Mth	3 Mth	6 Mth	1 Yr	2 Yrs			3 Yrs	4 Yrs	5 Yrs	
Casing / Panels and Frames				✓						Visual check for damage, rust and dust accumulation.	For highly corrosive environment, wash panels quarterly with water and neutral detergent solution. Wax panels. Repair / re-paint where required.
Insulation				✓						Visual check for insulation conditions.	Repair / replace insulation material.
Fan				✓						Visual check for run out of balance and dust attached	Clean off dust as necessary to negate possibility of fan running out of balance
Motor				✓ Ω						Visual check on wiring. Insulation resistance check to be carried out annually	Measure insulation resistance to earth with insulation tester. Insulation resistance should be more than 1MΩ.
Heat Exchanger				✓						Check for clogging by dust. Check for leaks / damage.	Clean air inlet side as necessary. Straighten any bent fins using fins comb.
Drain Pan/ Condensation line				✓						Check for obstructions and free flow of water	Clean to eliminate obstructions/ sludge and check condition of pan. Pour water to ensure free flow.
Filter *	✓									Check for clogging by dust.	Clean Filter
Temperature Readings				✓						Measure air on and air off	Place temperature probe in return and supply air of unit.
Ducting				✓						Inspect duct works for air gaps.	Re-tape any loose ducts.

* 1-3 month, subject to operating conditions and environment.

Outdoor Section										
Parts	Service Period					Detail of Service Check	Service Methods			
	1 Mth	3 Mth	6 Mth	1 Yr	2 Yrs			3 Yrs	4 Yrs	5 Yrs
Casing / Panels and Frames				✓					Visual check for damage, rust and dust accumulation.	For highly corrosive environment, wash panels quarterly with water and neutral detergent solution. Wax panels. Repair / re-paint where required.
Insulation				✓					Visual check for insulation conditions.	Repair / replace insulation material.
Fan				✓					Visual check for run out of balance and dust attached.	Clean off dust as necessary to negate possibility of fan running out of balance.
Motor				✓ Ω					Visual check on wiring. Insulation resistance check to be carried out annually.	Measure insulation resistance to earth with insulation tester. Insulation resistance should be more than 1MΩ.
Heat Exchanger				✓					Check for clogging by dust. Check for leaks / damage.	Clean air inlet side as necessary. Straighten any bent fins using fins comb.
Condensate Drain Line (if available)				✓					Check for obstructions and free flow of water.	Clean to eliminate obstructions / sludge and check condition of drain line. Pour water to ensure free flow.
Compressor				✓ Ω					Check for high / low pressure. Measure insulation resistance. Check compressor for abnormal noise/vibrations.	Measure insulation resistance. Should be more than 1MΩ.
Refrigeration Operational Readings				✓					Make note of operational reading in test cool/heat.	Check operating pressures, record superheat and subcooling values.
Safety Devices				✓					Check calibration of safety devices such as HP and LP controls, sensors, etc.	Check resistance of sensors, pressure cut in / cut out of pressure controls.
Faults				✓					Check for any previous fault history on unit.	Investigate any causes for previous faults, reset fault history.
Outdoor Fan Speed Capacitor				✓					Check for any bulge on the capacitors & capacitance.	Make it electrically safe prior to measure the capacitor capacitance. Measured capacitance should be within the printed tolerances on the capacitor.

21. Start Up and Commissioning Report

INSTALLATION INFORMATION			
CUSTOMER	Name:		Tel. Number:
	Address:		
INSTALLER	Name:		Tel. Number:
	Address:		
Site Address:			Date Installed:

Model:	Serial Number:
--------	----------------

CIRCUIT TEMPERATURE SETTINGS AND AMBIENT TEMPERATURE			
SYSTEM 1		SYSTEM 2	
Supply Air Temperature	°C	Supply Air Temperature	°C
Return Air Temperature	°C	Return Air Temperature	°C
Suction Temperature	°C	Suction Temperature	°C
Discharge Temperature	°C	Discharge Temperature	°C
Condenser Coil Temperature	°C	Condenser Coil Temperature	°C

Ambient Temperature	°C
---------------------	----

INDOOR FAN SETTINGS			
Indoor Fan Current	Amps	Outdoor Fan Current	Amps
Indoor Fan Airflow	l/s		
Set Static	Pa		

Check No Active Error Codes on the Unit	Checked:	<input type="checkbox"/>	Date Checked:	
---	----------	--------------------------	---------------	--

NOTE

Ensure to record operational settings on this table for future reference. Keep this manual in a safe place and readily available for service technicians.

THIS PAGE WAS INTENTIONALLY LEFT BLANK

THIS PAGE WAS INTENTIONALLY LEFT BLANK



©Copyright 2019 Actron Engineering Pty Limited ABN 34 002767240. ®Registered Trade Marks of Actron Engineering Pty Limited. ActronAir is constantly seeking ways to improve the design of its products, therefore specifications are subject to change without notice.