

# ADVANCE

## Split Ducted Unit

Installation and Commissioning Guide - Indoor Units (R-410A)

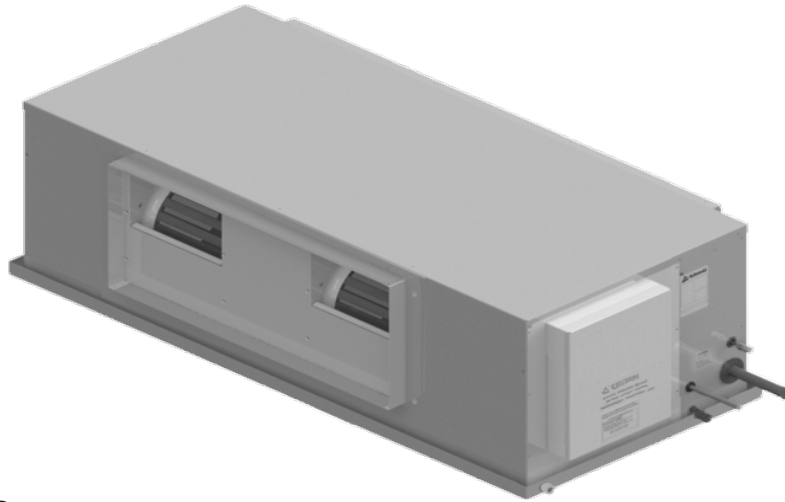

### Model Numbers

Single Fan Coil	Split Fan Coil*
EVV140S	EAA140S & EFV140S
EVV160S	EAA160S & EFV160S
EVV180S	EAA180S & EFV180S
EVV210S	EAA210S & EFV210S
EVV240S	EAA240S & EFV240S

\*Split Fan Coil has a separate coil and fan section

### **IMPORTANT NOTE:**

Please read this manual carefully before installing or operating your air conditioning unit.



## Table of Contents

<b>Introduction</b> .....	<b>4</b>
<b>Safety Instructions</b> .....	<b>5</b>
<b>Components Overview</b> .....	<b>6</b>
Indoor Unit Components Overview	6
Indoor Unit Electrical Panel Overview	6
<b>Unit Dimensions and Clearances</b> .....	<b>7</b>
EVV140S / EVV160S	7
EVV180S	8
EVV210S/EVV240S	9
<b>Two-Piece Fan Coil</b> .....	<b>10</b>
Coil Section	10
Fan Section	13
<b>Installation Instructions</b> .....	<b>15</b>
<b>Airflow Application Guidelines</b> .....	<b>17</b>
Duct Static Pressure	17
Final and Return Air Duct Sizes	17
Return Air Grille Sizes	18
Other Guidelines	18
Variable Airflow Test	18
<b>Unit Lifting Procedures</b> .....	<b>19</b>
Crane Lifting Method	19
Fork Lift Method	20
<b>Pallet Dimensions</b> .....	<b>21</b>
<b>Safety Drain Tray</b> .....	<b>22</b>
<b>Electrical Installation</b> .....	<b>23</b>
<b>Wiring Diagram</b> .....	<b>24</b>
<b>Electrical Connection</b> .....	<b>25</b>
<b>Data Cable Shielding Instructions</b> .....	<b>26</b>
<b>Circuit Breaker Size and Cable Size Requirement</b> .....	<b>27</b>
<b>Wall Controller Options</b> .....	<b>28</b>
Wall Controller Options	28
Wiring Configuration : Recommended	29
Wiring Configuration : Alternate	30
<b>Cable Length - Zoning</b> .....	<b>31</b>
Neo Zone Controller / Neo Zone Sensor	31
LR7-1 / LR7-2	32
<b>Wiring Connections</b> .....	<b>33</b>
LR7-1 and LC7-2 Wall Control Wiring Connections	33
NEO Wall Control Wiring Connections	33
LM-RS-2 Optional Sensor Wiring Connections	34
AERSS Optional Duct Sensor Wiring Connections	34
<b>Indoor Commissioning Guide</b> .....	<b>35</b>

**Zone Commissioning ..... 36**  
**Maintenance Frequency Checklist ..... 37**  
**Version History ..... 38**

## Introduction

**CONGRATULATIONS** on your purchase of an ActronAir air conditioning system! This unit has been designed and engineered to provide optimum air conditioning and to achieve maximum energy efficiency.

Your air conditioning system has been manufactured from the highest quality materials. Numerous “in house” and “external” inspection and test procedures were conducted to your air conditioner to ensure satisfactory operation.

### Information About This Guide

This guide provides installation instructions, specific to your ducted unit. Read this manual thoroughly and take into consideration all specifications and instructions to ensure correct installation and safe operation of your air conditioning system.

#### NOTE

Print a copy of this document and keep it for future reference. Ensure all technicians that work on the unit can refer to this manual at any time.

### Product Inspections

Check your air conditioning unit and all items against the invoice upon receiving your shipment. Inspect the unit, components and accessories for any sign of damage. If there is any damage to the unit, contact ActronAir Customer Care Department immediately on: **1300 522 722** to obtain a Goods Return Number.

Check the unit nameplate to verify the model, serial number, electrical rated specifications are correct.

### Codes, Regulations And Standards

The installer and/or contractor assumes responsibility to ensure that unit installation complies with the relevant council, state / federal codes, regulations and building code standards. All electrical wiring must be in accordance with current electrical authority regulations and all wiring connections to be as per electrical diagram provided with the unit

## Safety Instructions

- Only licensed HVAC technicians\* should install and service air conditioning equipment. Improper service or alteration by an unqualified technician could result in significant and major damage to the product or property which may render your warranty null and void. Such unqualified service could also lead to severe physical injury or death. Follow all safety instructions in this literature and all warning labels that are attached to the equipment.
- Prevailing WH&S regulations must be observed and will take precedence to the safety instructions contained on this manual. Safe work practices and environment must be the paramount importance in the performance of all the service procedures.
- Ensure that unit installation complies with relevant council regulations and building code standards.
- All electrical wiring must be in accordance with current electrical authority regulations and all wiring connections to be as per electrical diagram provided.
- Secure the fans against accidental contact. Beware of pinch point and sharp edges which can cause cutting injury.
- Always wear appropriate PPE, remove any dangling jewelery and protect long hair by wearing a cap.
- Make sure that safety guards and panel covers are always firmly secured and not damaged before and during operation of unit.
- This appliance is not intended for use by young children or infirm persons unless they have been adequately supervised by a responsible person to ensure that they can use the appliance safely. Young children should be supervised to ensure that they do not play with the appliance.
- Installer must incorporate a means of electrical disconnection (isolator) in the sub mains fixed wiring in accordance with the latest edition of the AS/NZS 3000 (also known as Australian Wiring Rules).
- Secure the power cords and control cables that goes in/out the unit. Use the cable ties provided in the control box.

\*Qualifications required will be appropriate Electrical, Refrigeration and Refrigerant Handling License and Training dependent on local State/Territory regulations.

### DANGER

#### **Hazardous Voltage - Risk of Electrocutation.**

TURN-OFF the power from main isolator before proceeding with any service work of the unit. Observe proper LOCK-OUT/TAG-OUT (LOTO) procedures for electrical appliances in order to prevent accidental switching-on of the power supply.

### WARNING

EC Motors and Compressor Drives are fitted with high power capacitors and can have dangerous residual voltages at motor/drive terminals after power has been isolated. Wait at least 5 minutes after power isolation and test for any residual voltage before beginning service work.

### CAUTION

#### **Beware of Rotating Fans !**

Ensure that indoor and outdoor fans are isolated and have come to a complete stand still before servicing the equipment. Beware of pinch point and sharp edges which can cause cutting injury. Secure the fans against accidental contact. Always wear appropriate PPE and remove any dangling jewellery and protect long hair by wearing a cap. Ensure that no loose clothing can be caught / entangled in moving parts.

### **VISUAL INSPECTION AND WORK ASSESSMENT**

Work areas and conditions must first be assessed and evaluated for any potential hazardous conditions. It is also important to be familiar with the unit parts and components before proceeding with any service task.

## Components Overview

### Indoor Unit Components Overview

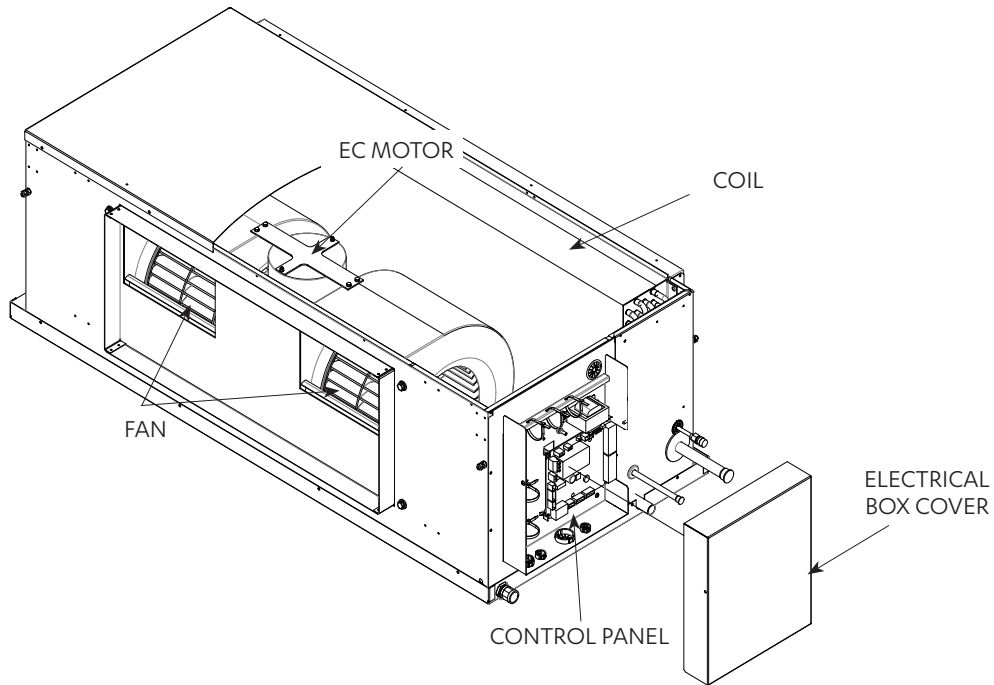

### Indoor Unit Electrical Panel Overview

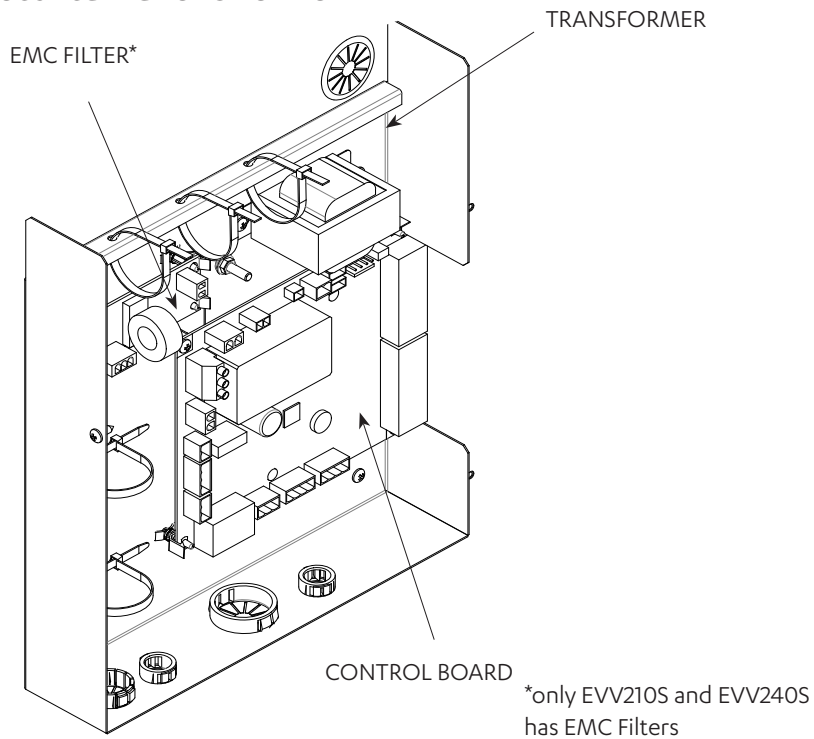

**Unit Dimensions and Clearances**

**EVV140S / EVV160S**

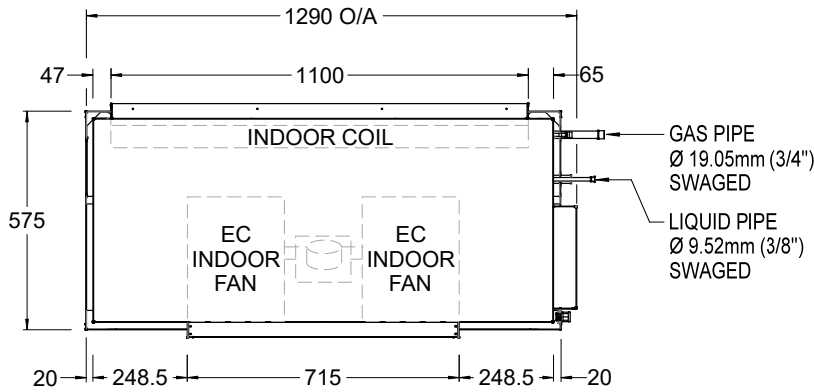

**TOP VIEW**

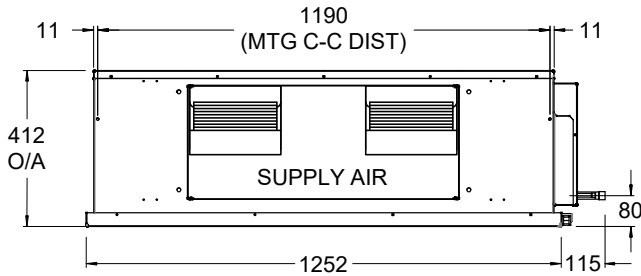

**FRONT VIEW**

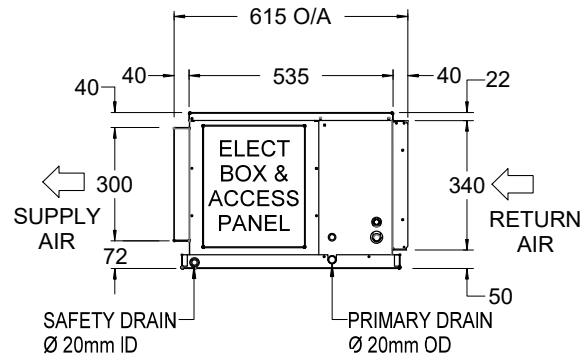

**SIDE VIEW**

OVERALL NOMINAL DIMENSION (H X W X D)  
 = 412 X 1290 X 615  
 SUPPLY DUCT (H X W) = 300 X 715  
 RETURN DUCT = 340 X 1100  
 CONDENSATE DRAIN CONNECTION = 20mm OD

UNIT MODEL NUMBER	UNIT WEIGHT (kg)
EVV140S	53
EVV160S	56

**MINIMUM SERVICE ACCESS AREAS AND AIRFLOW CLEARANCES**

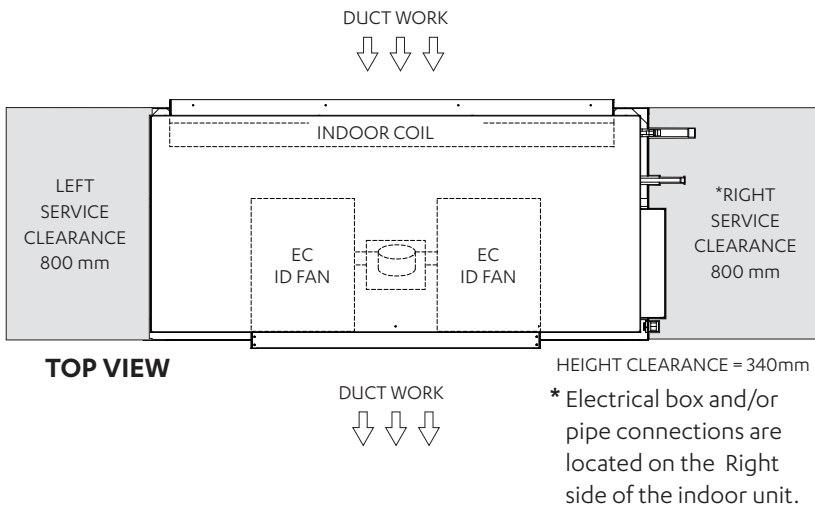

**TOP VIEW**

**NOTES:**

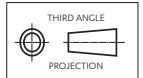

- Do not scale drawing. All dimensions are in mm unless specified.
- Service Clearances given are suggested minimum based on the condition that the spaces around the units are free from any obstructions and a walkway passage of 1000mm between the units or between the unit and the outside perimeter is available.
- Minimum service access clearances are responsibilities of the installer, ActronAir will not be held liable for any extra charges incurred due to lack of access.
  - Left Service Clearance can be 100mm minimum if Right Service Clearance is applicable.
  - Right Service Clearance can be 600mm minimum if Left Service Clearance is applicable.
  - Height Service Clearance can be 100mm minimum if Right Service Clearance is applicable.

**EVV180S**

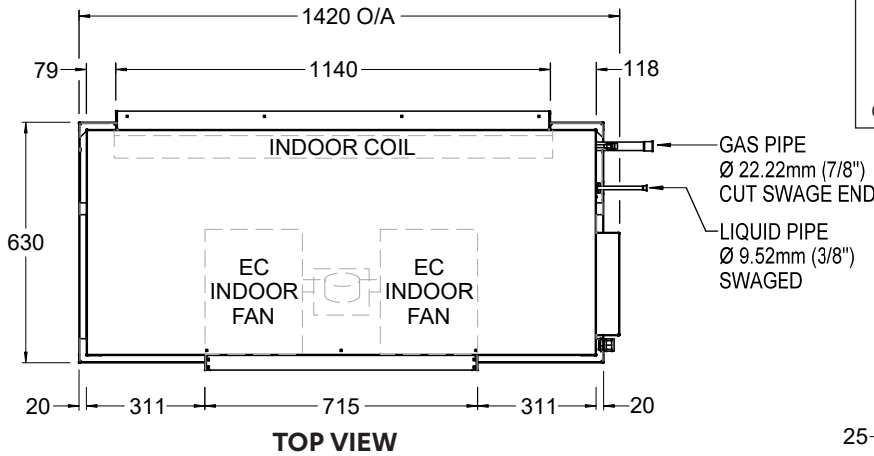

**TOP VIEW**

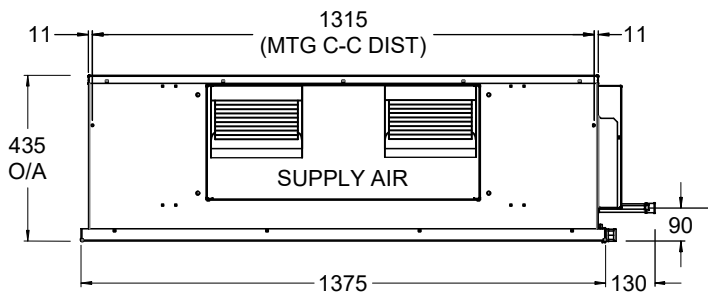

**FRONT VIEW**

OVERALL NOMINAL DIMENSION (H X W X D)  
= 435 X 1420 X 680  
SUPPLY DUCT (H X W) = 300 X 715  
RETURN DUCT = 360 X 1140  
CONDENSATE DRAIN CONNECTION = 20mm OD

UNIT MODEL NUMBER	UNIT WEIGHT (kg)
EVV180S	69

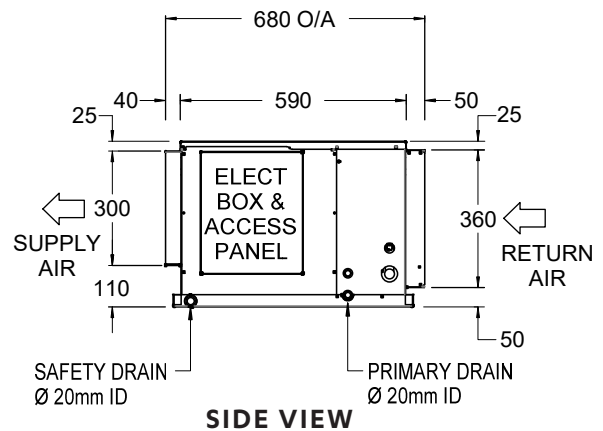

**SIDE VIEW**

**MINIMUM SERVICE ACCESS AREAS AND AIRFLOW CLEARANCES**

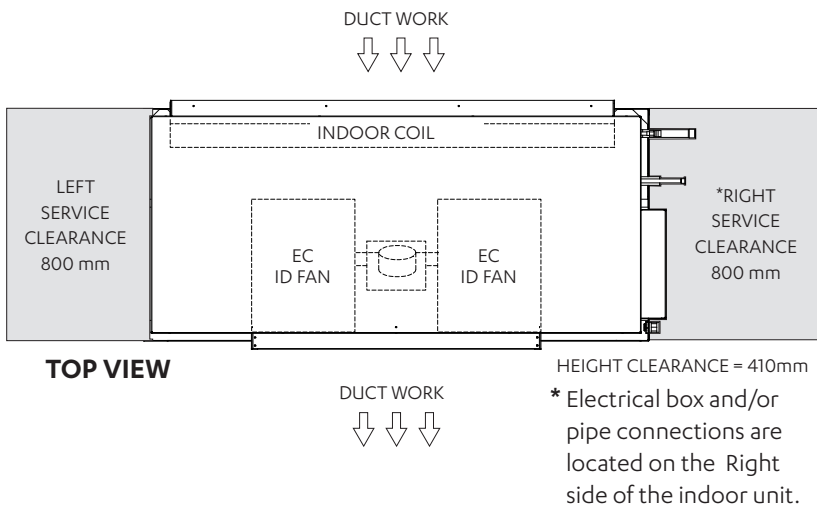

**TOP VIEW**

**NOTES:**

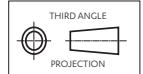

- Do not scale drawing.  
All dimensions are in mm unless specified.
- Service Clearances given are suggested minimum based on the condition that the spaces around the units are free from any obstructions and a walkway passage of 1000mm between the units or between the unit and the outside perimeter is available.
- Minimum service access clearances are responsibilities of the installer, ActronAir will not be held liable for any extra charges incurred due to lack of access.
  - Left Service Clearance can be 100mm minimum if Right Service Clearance is applicable.
  - Right Service Clearance can be 600mm minimum if Left Service Clearance is applicable.
  - Height Service Clearance can be 100mm minimum if Right Service Clearance is applicable.



## EVV210S/EVV240S

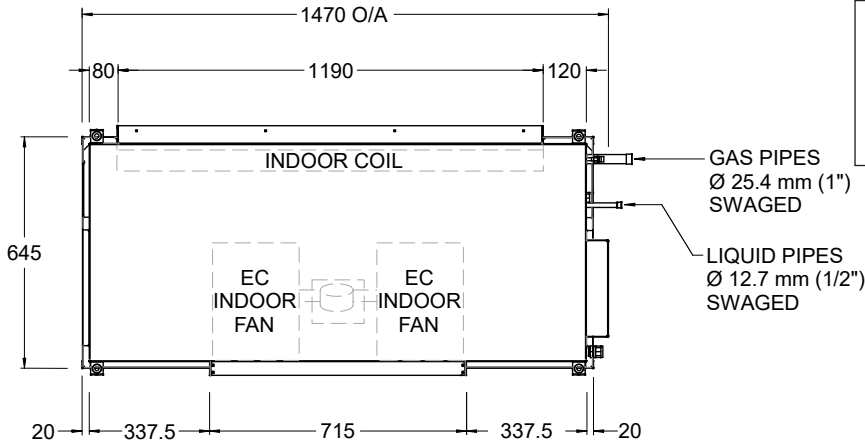

**TOP VIEW**

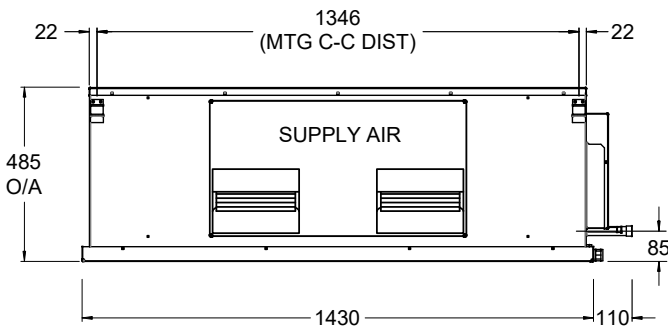

**FRONT VIEW**

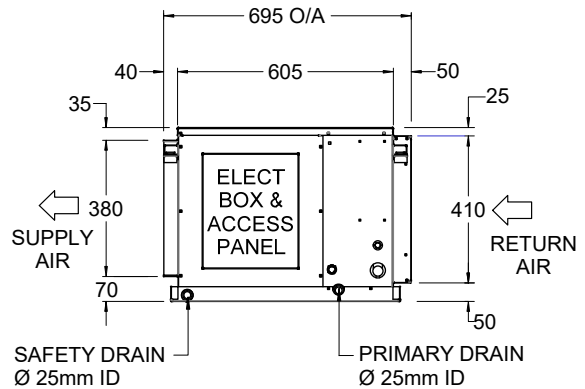

**SIDE VIEW**

OVERALL NOMINAL DIMENSION (H X W X D)  
 = 485 X 1470 X 695  
 SUPPLY DUCT (H X W) = 380 X 715  
 RETURN DUCT = 410 X 1190  
 CONDENSATE DRAIN CONNECTION = 20mm OD

UNIT MODEL NUMBER	UNIT WEIGHT (kg)
EVV210S	75
EVV240S	78

### MINIMUM SERVICE ACCESS AREAS AND AIRFLOW CLEARANCES

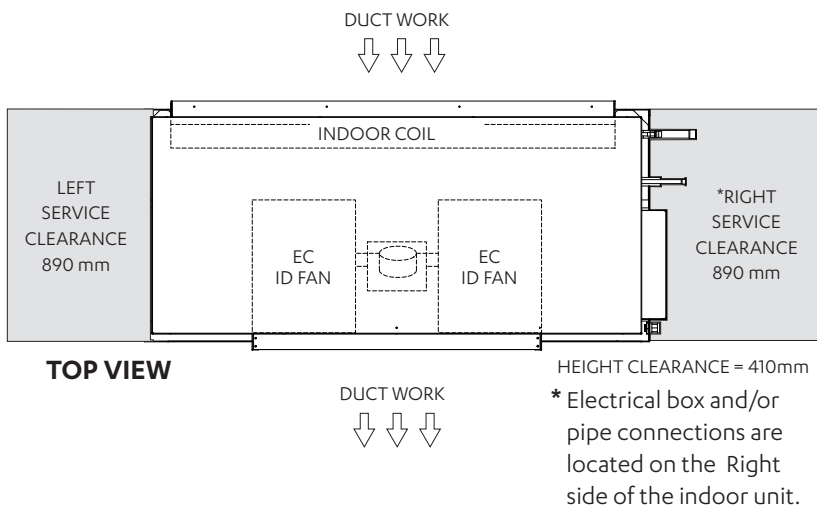

**TOP VIEW**

### NOTES:

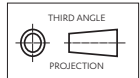

- Do not scale drawing.  
All dimensions are in mm unless specified.
- Service Clearances given are suggested minimum based on the condition that the spaces around the units are free from any obstructions and a walkway passage of 1000mm between the units or between the unit and the outside perimeter is available.
- Minimum service access clearances are responsibilities of the installer, ActronAir will not be held liable for any extra charges incurred due to lack of access.
  - Left Service Clearance can be 100mm minimum if Right Service Clearance is applicable.
  - Right Service Clearance can be 600mm minimum if Left Service Clearance is applicable.
  - Height Service Clearance can be 100mm minimum if Right Service Clearance is applicable.

## Two-Piece Fan Coil

### Coil Section

EAA140S / EAA160S

OVERALL NOMINAL DIMENSION (H X W X D)  
 = 410 X 1252 X 342  
 SUPPLY DUCT (H X W) = 345 X 900  
 RETURN DUCT = 345 X 900

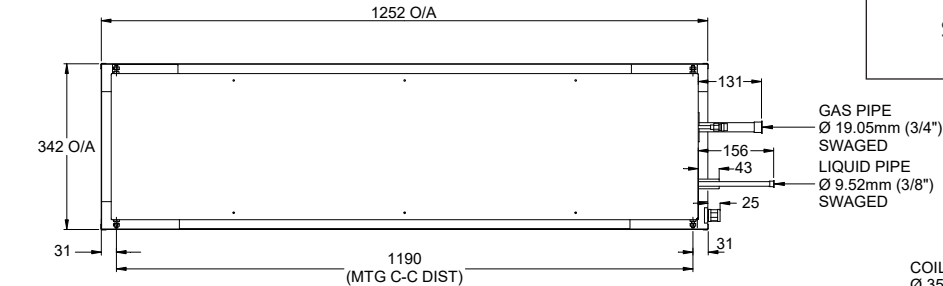

TOP VIEW

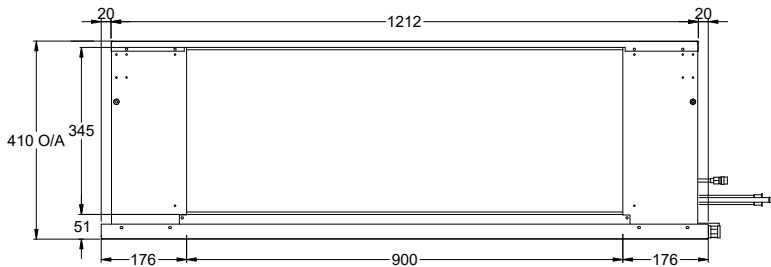

FRONT VIEW - SUPPLY AIR

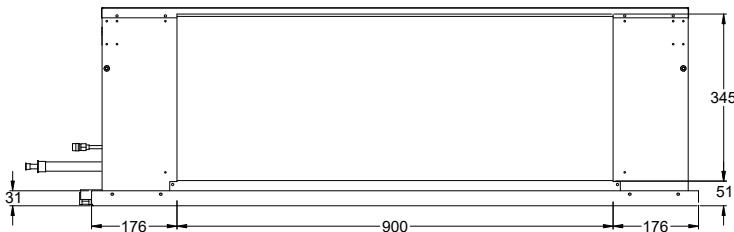

REAR VIEW - RETURN AIR

GAS PIPE  
 Ø 19.05mm (3/4")  
 SWAGED  
 LIQUID PIPE  
 Ø 9.52mm (3/8")  
 SWAGED

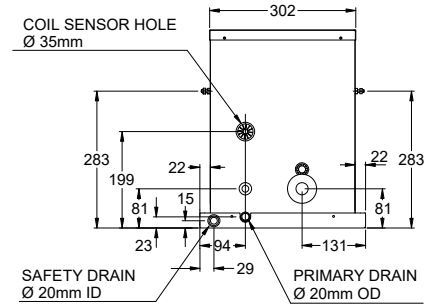

SIDE VIEW

UNIT MODEL NUMBER	UNIT WEIGHT (kg)
EAA140S	27
EAA160S	29

### MINIMUM SERVICE ACCESS AREAS AND AIRFLOW CLEARANCES

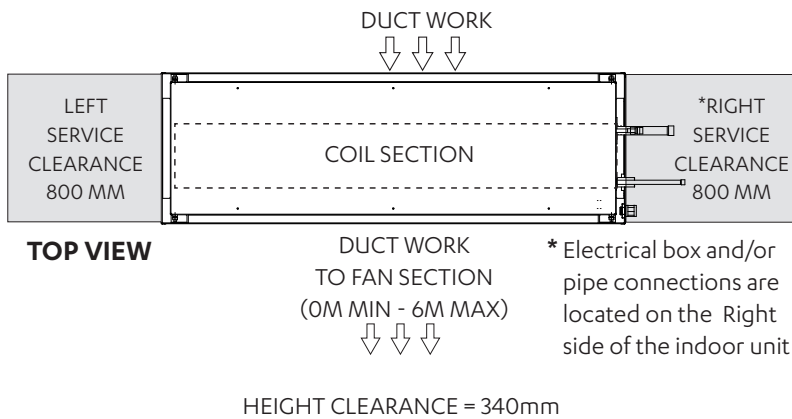

TOP VIEW

### NOTES:

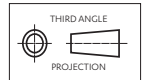

- Do not scale drawing.  
All dimensions are in mm unless specified.
- Service Clearances given are suggested minimum based on the condition that the spaces around the units are free from any obstructions and a walkway passage of 1000mm between the units or between the unit and the outside perimeter is available.
- Minimum service access clearances are responsibilities of the installer, ActronAir will not be held liable for any extra charges incurred due to lack of access.
  - Left Service Clearance can be 100mm minimum if Right Service Clearance is applicable.
  - Right Service Clearance can be 600mm minimum if Left Service Clearance is applicable.
  - Height Service Clearance can be 100mm minimum if Right Service Clearance is applicable.

## EAA180S

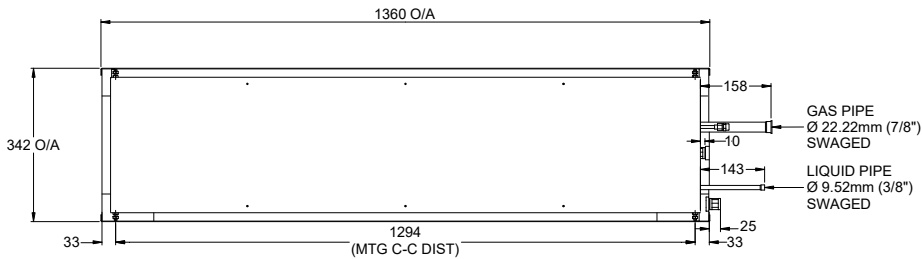

**TOP VIEW**

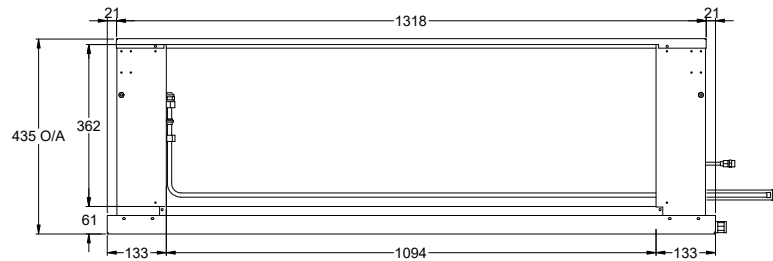

**FRONT VIEW - SUPPLY AIR**

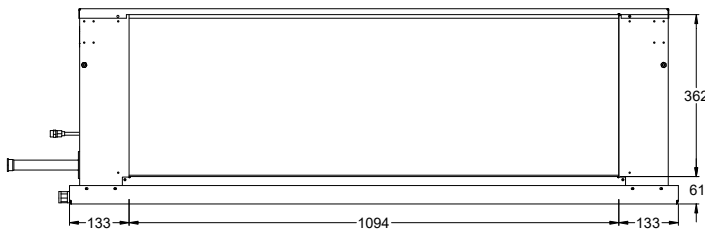

**REAR VIEW - RETURN AIR**

OVERALL NOMINAL DIMENSION (H X W X D)  
= 435 X 1360 X 342  
SUPPLY DUCT (H X W) = 362 X 1094  
RETURN DUCT = 362 X 1094

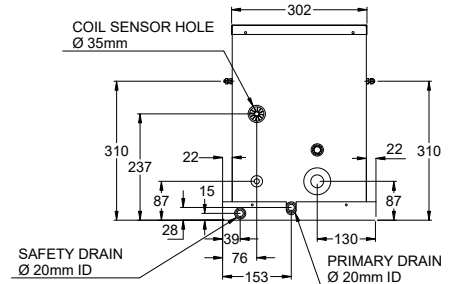

**SIDE VIEW**

UNIT MODEL NUMBER	UNIT WEIGHT (kg)
EAA180S	39

### MINIMUM SERVICE ACCESS AREAS AND AIRFLOW CLEARANCES

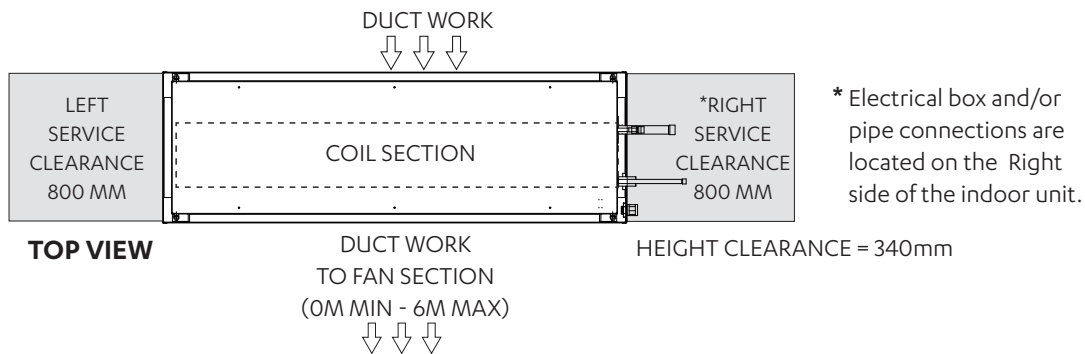

### NOTES:

- Do not scale drawing. All dimensions are in mm unless specified.
- Service Clearances given are suggested minimum based on the condition that the spaces around the units are free from any obstructions and a walkway passage of 1000mm between the units or between the unit and the outside perimeter is available.
- Minimum service access clearances are responsibilities of the installer, ActronAir will not be held liable for any extra charges incurred due to lack of access.
  - Left Service Clearance can be 100mm minimum if Right Service Clearance is applicable.
  - Right Service Clearance can be 600mm minimum if Left Service Clearance is applicable.
  - Height Service Clearance can be 100mm minimum if Right Service Clearance is applicable.

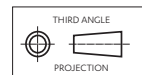

## EAA210S / EAA240S

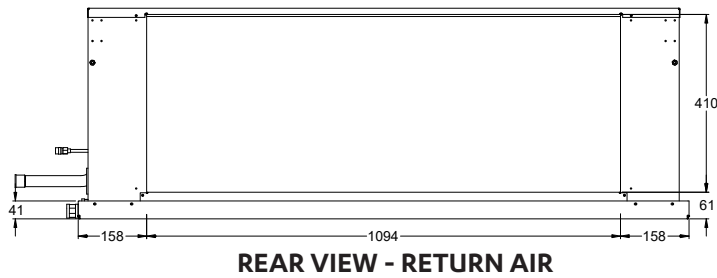
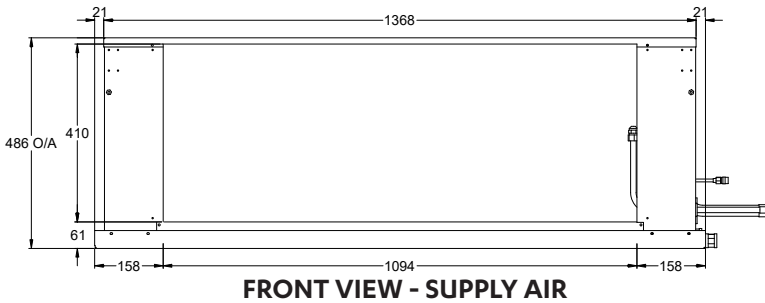
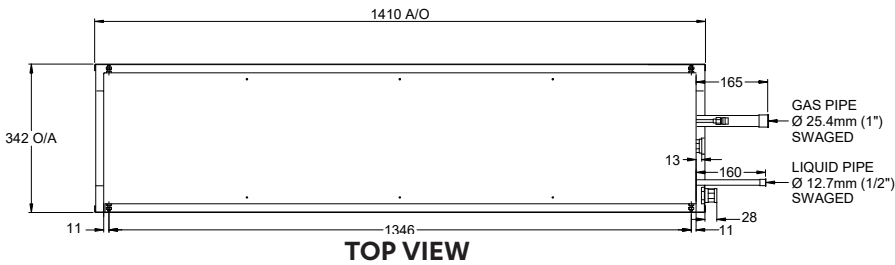

OVERALL NOMINAL DIMENSION (H X W X D)  
= 486 X 1410 X 342  
SUPPLY DUCT (H X W) = 410 X 1094  
RETURN DUCT = 410 X 1094

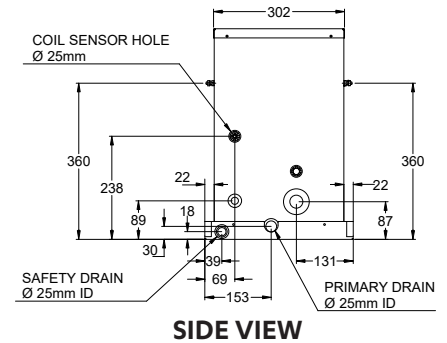

UNIT MODEL NUMBER	UNIT WEIGHT (kg)
EAA210S	40
EAA240S	43

### MINIMUM SERVICE ACCESS AREAS AND AIRFLOW CLEARANCES

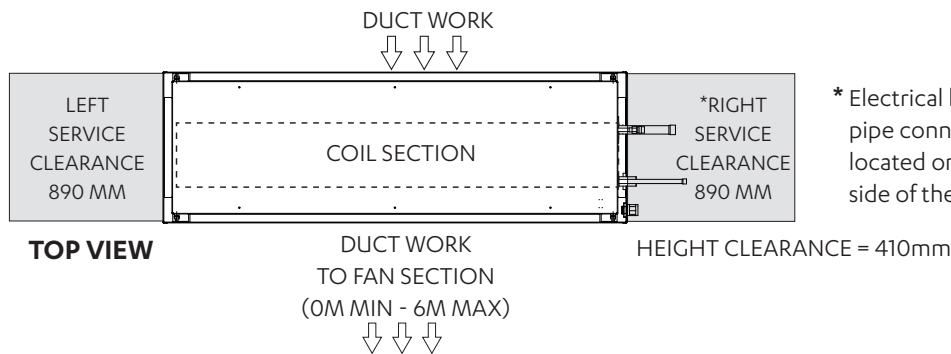

\* Electrical box and/or pipe connections are located on the Right side of the indoor unit.

### NOTES:

- Do not scale drawing. All dimensions are in mm unless specified.
- Service Clearances given are suggested minimum based on the condition that the spaces around the units are free from any obstructions and a walkway passage of 1000mm between the units or between the unit and the outside perimeter is available.
- Minimum service access clearances are responsibilities of the installer, ActronAir will not be held liable for any extra charges incurred due to lack of access.
  - Left Service Clearance can be 100mm minimum if Right Service Clearance is applicable.
  - Right Service Clearance can be 600mm minimum if Left Service Clearance is applicable.
  - Height Service Clearance can be 100mm minimum if Right Service Clearance is applicable.

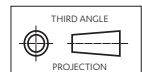

**Fan Section**

EFV140S / EFV160S / EFV180S

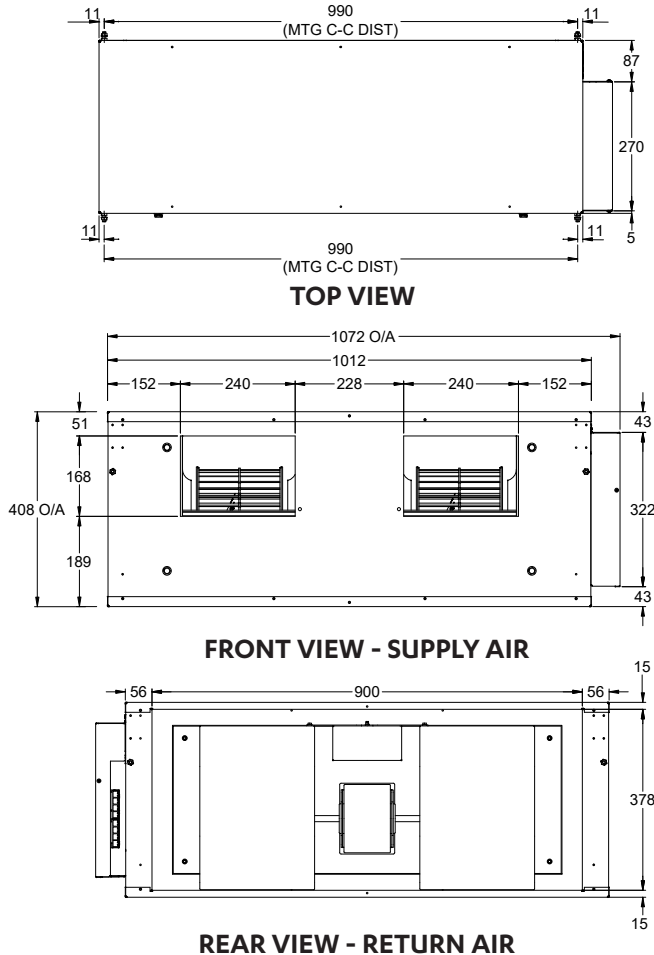

OVERALL NOMINAL DIMENSION (H X W X D)  
= 408 X 1072 X 362  
SUPPLY DUCT (H X W) = 168 X 707  
RETURN DUCT = 378 X 900

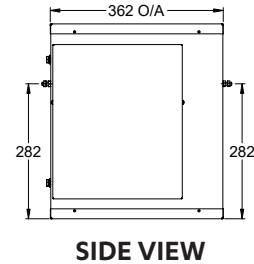

UNIT MODEL NUMBER	UNIT WEIGHT (kg)
EFV140S / EFV160S / EFV180S	31

**NOTES:**

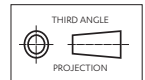

- Do not scale drawing. All dimensions are in mm unless specified.
- Service Clearances given are suggested minimum based on the condition that the spaces around the units are free from any obstructions and a walkway passage of 1000mm between the units or between the unit and the outside perimeter is available.
- Minimum service access clearances are responsibilities of the installer, ActronAir will not be held liable for any extra charges incurred due to lack of access.
  - Left Service Clearance can be 100mm minimum if Right Service Clearance is applicable.
  - Right Service Clearance can be 600mm minimum if Left Service Clearance is applicable.
  - Height Service Clearance can be 100mm minimum if Right Service Clearance is applicable.

**MINIMUM SERVICE ACCESS AREAS AND AIRFLOW CLEARANCES**

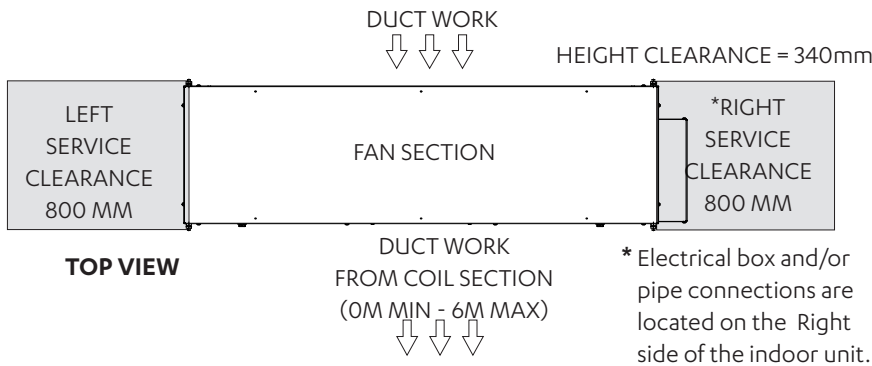

## EFV210S / EFV240S

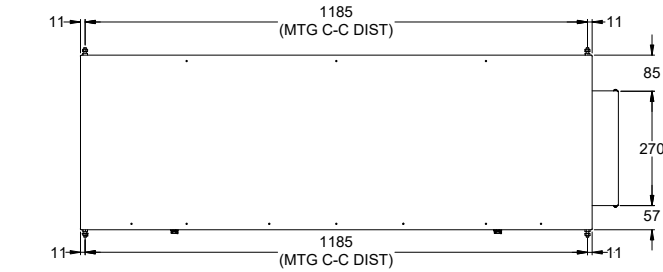

**TOP VIEW**

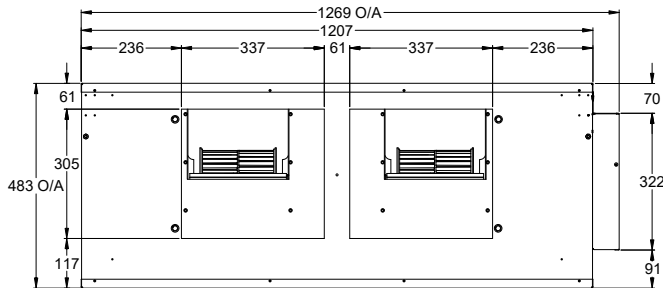

**FRONT VIEW - SUPPLY AIR**

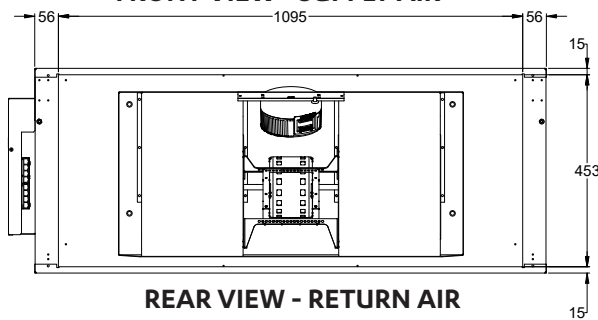

**REAR VIEW - RETURN AIR**

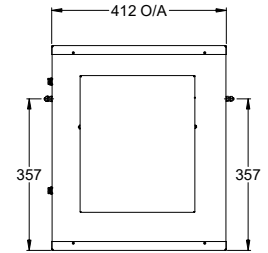

**SIDE VIEW**

OVERALL NOMINAL DIMENSION (H X W X D)  
= 483 X 1269 X 412  
SUPPLY DUCT (H X W) = 305 X 734  
RETURN DUCT = 453 X 1095

UNIT MODEL NUMBER	UNIT WEIGHT (kg)
EFV210S / EFV240S	43

**NOTES:**

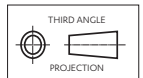

- Do not scale drawing. All dimensions are in mm unless specified.
- Service Clearances given are suggested minimum based on the condition that the spaces around the units are free from any obstructions and a walkway passage of 1000mm between the units or between the unit and the outside perimeter is available.
- Minimum service access clearances are responsibilities of the installer, ActronAir will not be held liable for any extra charges incurred due to lack of access.
  - Left Service Clearance can be 100mm minimum if Right Service Clearance is applicable.
  - Right Service Clearance can be 600mm minimum if Left Service Clearance is applicable.
  - Height Service Clearance can be 100mm minimum if Right Service Clearance is applicable.

**MINIMUM SERVICE ACCESS AREAS AND AIRFLOW CLEARANCES**

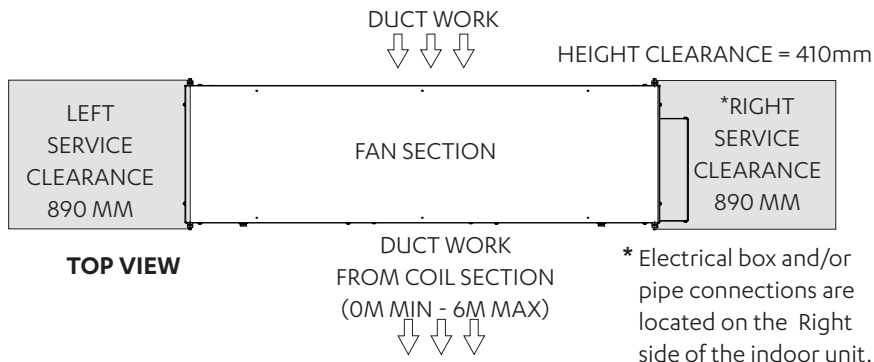

**TOP VIEW**

## Installation Instructions

The installation instructions provided below are intended as a guide only and does not supersede the relevant council, state and federal codes, regulations and building code standards. Compliance and consultation with the authorities having jurisdiction with the installation of this equipment is the responsibility of the installer. ActronAir will not be held liable for any damages or costs as a result of the installer's failure to comply. Please refer to the matching outdoor unit Installation and Commissioning Guide for further information and details.

### Lifting The Unit

The installation instructions provided, in Unit Lifting Procedures, adhere to WH&S regulations for safe and secure lifting practices in order to prevent physical injury. The suggested lifting procedures are outlined as reference guide to safely lift and transport the unit, however, this does not over rule the industry WH&S practices.

### Location

This unit is intended for indoor installation only. It is highly recommended that this indoor unit and accessories, particularly zone barrels, be mounted in the roof cavity.

Mount the unit in a stable and rigid support wherein the weight is properly distributed, such as roof joist and rafters. Take into consideration the minimum service access clearances provided in the unit drawings.

Locate the indoor unit away from the areas where noise is a critical factor. Use rubber mounting pad (not supplied) in order to minimize the transfer of noise and vibration into building structures.

An optional hanging bracket assembly and rubber grommet (supplied as standard with some models) is also available to secure the indoor unit into the roof rafters. This installation configuration is most suitable for installation that require the unit to be rigidly secured up from the roof joist.

### NOTE

In locations where high humidity is expected, additional insulation shall be applied to the indoor unit.

### Condensate and Safety Tray Drainage

An integrated safety drain tray is provided as a standard inclusion to your indoor unit in order to reduce the potential of condensate damage to the roof. Drain Kit (not included in some models) is provided for the condensate drain to be externally trapped from the indoor unit. Suggested condensate and safety tray drainage instructions are provided at the proceeding page for your reference.

### NOTE

The included safety tray is provided for collection of internal condensation and for back up in case of main drain blockage. In locations where high humidity is expected, additional insulation or safety tray may be required to provide protection for externally formed condensation.

### Supply Air and Return Air Duct

The indoor unit is supplied with duct flange as standard in order to facilitate the system's duct connection into the unit. Supply and return air duct works must be adequately sized to meet the system's air flow and static pressure requirements. Refer to the unit drawing for supply air and return air duct dimensions, specific to your requirement.

### NOTES

In locations where high humidity is expected, ensure appropriate duct insulation level is considered for the environment. Inadequate insulation can result in condensation forming on the ductwork's surface, potentially leading to dripping condensation on the ceiling.

Ducted work should be adequately supported in order to prevent cold bridging.

Fit a flexible duct connection in between the unit and the duct system, where noise and vibration is a critical consideration.

**Return Air Filter**

Air filters must be provided in the return air side of the unit to maintain the efficiency and prolong the operation of the unit. These are also paramount to satisfy requirement for a clean and hygienic room condition. Return Air filters must be placed in an easily accessible location for service and maintenance.

**NOTES**

- Return Air filters are not supplied with the unit as individual air filtration requirements vary.
- Ensure that filters are cleaned / replaced regularly.

**Air Plenums / Duct Plates (Optional)**

Supply Air and Return Air plenums and duct plates (twin-spigot) are available as an option in order to facilitate your duct system connection to the indoor unit. The supply air plenums come in 1-way, 2-way and 3-way options, which offer a wider solutions to your different air distribution requirements.

**NOTE**

All exposed metal surfaces of the duct spigots should be adequately insulated when connecting ductwork to ensure performance and reduce the risk of condensation. All air gaps shall be appropriately sealed.

**Split Fan Coil System (Optional)**

The ActronAir innovative 2-piece fan coil system provides a solution to your difficult and tight roof space installation requirement. This versatile system has a separate fan and coil sections. Each of the compact and lightweight section is simply installed in two separate locations and joined by flexible duct system. Air ducts are attached to each section of the split fan coil by both of the supply air plenum and the twin spigot duct plate.

**Fan Coil With Vertical Discharge (Optional)**

An upright Fan Coil with vertical supply air discharge is also available wherein installation applications require the placement of the unit down in a closet, basement or garage. Please refer to the Technical Catalogue of your indoor unit for dimensions, installation details and specifications.

**Field Pipe Connections**

Specifications and installation requirements for field pipe connections are contained in the Installation and Commissioning Guide of the outdoor unit that matches your indoor unit. Please refer to this guide and thoroughly understand the procedures for safe and correct indoor and outdoor connection.

**Field Electrical Connection**

The power supply and control communication data to the indoor unit are supplied via the outdoor unit. Please refer to the wiring diagram supplied with the outdoor unit for specifications.

All electrical work must be performed by a licensed electrician and must conform with the wiring diagram and all relevant electrical authorities.

**NOTES**

This indoor unit is designed to match only with an ActronAir Series outdoor unit as specified in the Technical Selection Catalogue.

The unit is supplied with factory charged dry air. Be aware of the pressurised air charge when purging. Remove the caps from the connection points and purge the system only when the field pipe connections are ready to be completed.



## Airflow Application Guidelines

ActronAir Advance systems are designed with a self-learning function to sense the installation zoning of a system to deliver the required balanced airflow. The following are some recommendations to make this system work to its optimum design.

### Duct Static Pressure

The ideal system design is for a duct with a TI Static pressure of 125Pa. This design static for the VAF (variable air flow) system allows for the optimal combination for duct sizing and energy efficiency of the system. This compares with 150 to 250 Pa for standard systems.

### Final and Return Air Duct Sizes

There are set parameters for sizing and design of both final duct (from the last take off to the outlet) and return air duct and fittings. The following duct sizes are based on a maximum final duct air velocity of 3 m/s and a maximum return air velocity of 4 m/s.

Other Recommendations are:

- Main duct velocity is recommended to be within 6-7 m/s.
- Branch duct velocity is recommended to be within 4-6 m/s.

Model	Nominal Supply Air Flow (L/s)	Minimum Supply Air Flow (L/s)	Minimum Final Air Duct Sizes	Return Air Duct Sizes
EVV140S / EFV140S	630	220	1 x 300 or 2 x 200	2 x 350
EVV160S / EFV160S	750	250	1 x 300 or 2 x 200	2 x 400
EVV180S / EFV180S	850	300	1 x 300 or 2 x 200	2 x 400
EVV210S / EFV210S	1020	350	1 x 350 or 2 x 250	2 x 450
EVV240S / EFV240S	1130	400	2 x 250	2 x 450

#### NOTE

Above values are designed to minimize noise generation at supply air outlet.

To reduce noise issues at the supply air grilles careful consideration must be taken when designing for minimum air quantity.(See above table) e.g. an EVV180S / EFV180S has a minimum supply air quantity of 300 l/s, this is too much airflow for 1 x outlet to handle and in this instance 2 x outlets correctly sized is recommended.

- On minimum zone selection two outlets should be considered for airflow and noise purpose.
- Systems larger than 13kw it is recommended to have 2 x outlets or more for minimum zones.

When an air balance is carried out, it is recommended that the airflow is adjusted at the branch take off points to each outlet is recommended instead of balancing dampers at the supply air outlet. This will also reduce noise at the supply air outlet/grille and eliminate any excessive static pressure.

#### NOTE

Supply and Return Air Plenums must be as per ActronAir Plenums or equal to, or lower static pressure.

### Return Air Grille Sizes

Careful consideration is to be given to pressure drops through return air grilles, air filters and crimped or tight bends in duct. Grille sizes shown are based on a velocity of 2.5 m/s, sizes shown are free area, please ensure your suppliers are aware of these requirements.

Model	Nominal Supply Air Flow (L/s)	Minimum Return Air Grille Sizes (free area)	Maximum Supply Air Flow (L/s)	Minimum Return Air Grille Sizes (free area)	Recommended Return Air Grilles (For nominal air flow)
EVV140S / EFV140S	630	0.26 m <sup>2</sup>	900	0.36 m <sup>2</sup>	540 x 640 = 0.35 m <sup>2</sup>
EVV160S / EFV160S	750	0.30m <sup>2</sup>	900	0.36m <sup>2</sup>	540 x 740 = 0.40m <sup>2</sup>
EVV180S / EFV180S	850	0.36m <sup>2</sup>	1020	0.41m <sup>2</sup>	540 x 890 = 0.48m <sup>2</sup>
EVV210S / EFV210S	1020	0.40m <sup>2</sup>	1200	0.48m <sup>2</sup>	540 x 890 = 0.48m <sup>2</sup>
EVV240S / EFV240S	1130	0.44m <sup>2</sup>	1320	0.53m <sup>2</sup>	540 x 890 = 0.48m <sup>2</sup>

**NOTE**

To achieve maximum airflow you may need to upsize your return air grille one size larger than our 'Recommended Return Air Grilles' shown above.

Care must be taken to identify return air paths for each zone for minimal static. This may include undercut doors or additional return air duct and grilles.

### Other Guidelines

- Larger master bedrooms or parents retreats may have privacy issues with undercut doors, so a separate return duct or transfer duct may be needed. The use of walk in robes for positioning of return air grilles allows for a better finish.
- Special attention may also be required in home theaters where rooms are sealed for noise breakout. A dedicated return air duct with zone barrel linked to the supply air zone barrel may be required in this case.
- Small critical areas such as a study, which are below the minimum air flow and duct sizing, would need to be coupled with another area.
- Dual Master controllers are also recommended for two storey homes or larger single storey homes.

### Variable Airflow Test

**NOTES**

- Test to be completed on zoned systems after commissioning of the fan is completed.
- Zone 1 has been used as an example. Applications where the system has been designed to cool only selected zones at any one time, airflow may differ. For these applications complete test on a zone selected during the fan commissioning process.

1. Open all available zones and select **AUTO** fan mode on the wall control.
2. Allow 3 minutes for fan to adjust speed.
3. Check airflow at any outlet from Zone 1.
4. Close all zones except Zone 1.
5. Allow 3 minutes for fan to adjust speed.
6. Check airflow at the same outlet.
7. The airflow at this outlet should remain reasonably constant.
8. Switch to the manual mode **HIGH**.
9. A significant increase in airflow should be noted.
10. Switch to medium, then low and note airflow drops accordingly.

## Unit Lifting Procedures

### WARNING

WH&S regulations must be observed and will take precedence during lifting process.  
Do not use pipes or tube coming out from the unit to lift the unit.

### Crane Lifting Method

### DANGER

Make sure rigging equipment, accessories and plant are sufficiently and safely capable to lift the unit in order to prevent potential damage to property, severe personal injury or death. Please check unit weight and weight distribution points on unit drawing dimensions section.

### NOTES

- Crane lifting method is recommended for high rise lifting.
- Refer to catalogue for unit weight before selecting shackles and slings.
- Lifting procedure and unit model shown are suggestions and for illustration purposes only.
- It is highly recommended that installer observe current industry safe rigging and lifting procedure.

### NOTE

All drawings are for illustration purposes only. Actual unit may vary depending on the model.

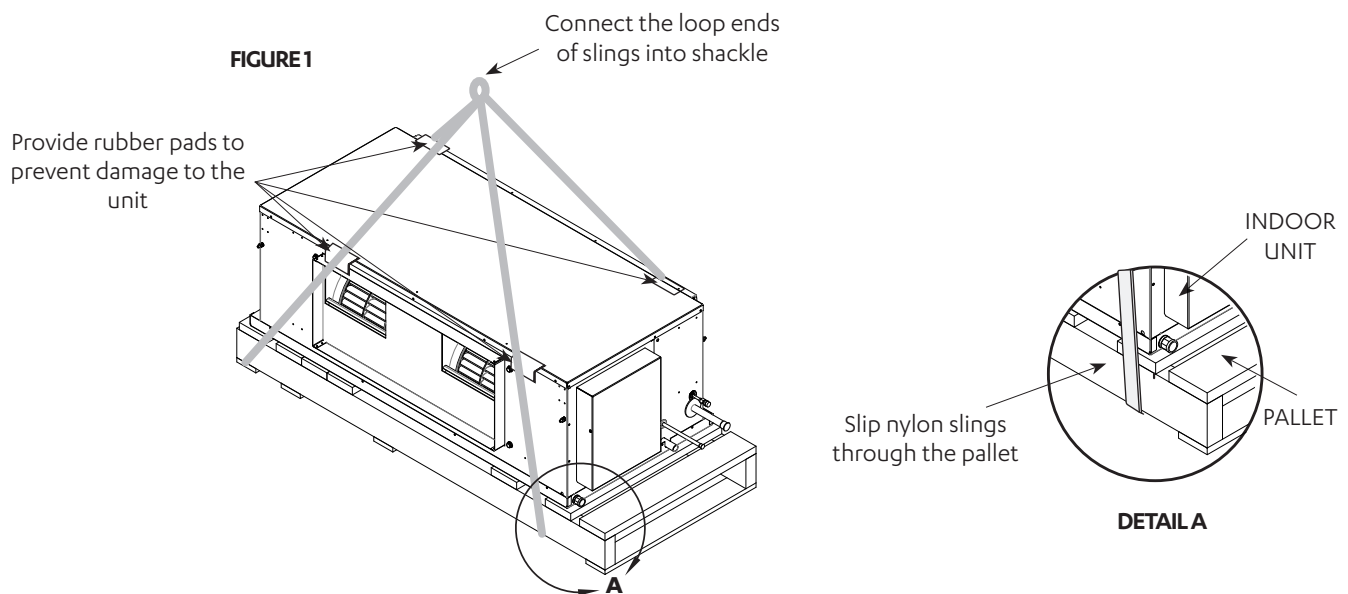

### Equipment Required For Crane Lifting:

- 1 x shackle
- 2 x nylon slings
- 4 x rubber pads

**NOTE**

Refer to catalogue for unit weight before selecting shackles and slings.

**Procedure:**

1. Slip nylon slings through the pallet as shown in Figure 1.
2. Use Bow or Dee shackle to connect the slings.
3. Ensure slings are protected by rubber pads or similar if slings are draped across unit edges, corners, or air grilles . This will prevent the unit from being damaged during lifting.
4. Test lift the unit to determine exact unit balance and stability before hoisting it to the installation location.

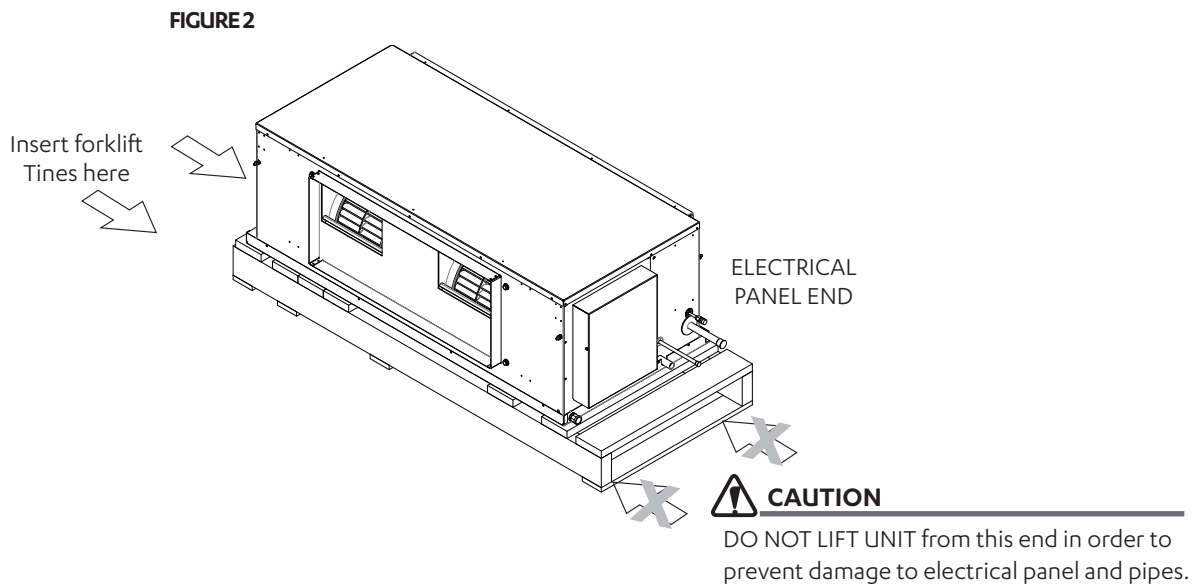
**Fork Lift Method****Procedure:**

1. To move the unit around with a forklift, insert the fork tines through the unit feet assembly, as shown in Figure 2.
2. Do not lift the unit through the electrical panel end of the unit (See illustration for location of electrical panel end).

**CAUTION**

Length of fork lift tines must pass the unit middle section, in order to safely carry the unit.

## Pallet Dimensions

**EVV140-180S**

PALLET FORK LIFTING HOLE DIMENSIONS  
ALL DIMENSIONS IN MM.

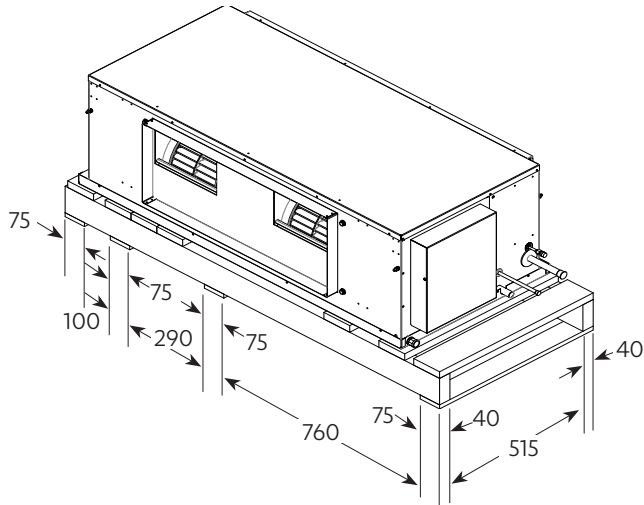

**EVV210-240S**

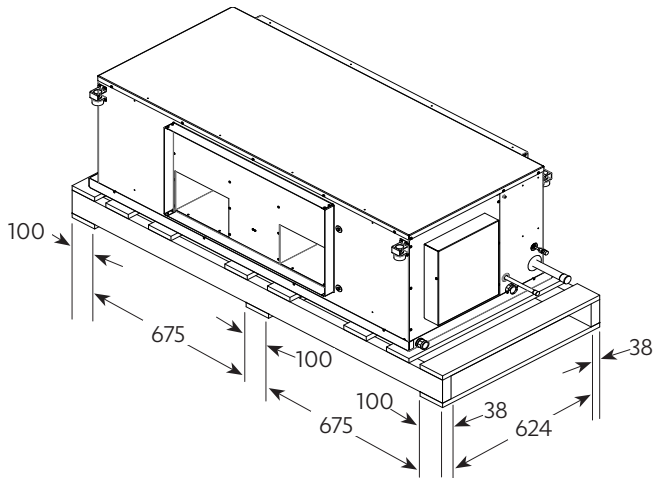

## Safety Drain Tray

### NOTES

- Do not use pipes or tube coming out from the unit to lift the unit.
- Support drain line for long pipe run.
- Refer to unit dimension page for specification of drain connectors.
- To reduce the risk of condensation forming on the drain line, the drain line should be covered with appropriate thermal insulation.
- Test condensate drain installation to ensure that water flows freely and does not leak. Also check that the drain tray does not overflow.
- All drawings are for illustration purposes only. Actual unit may vary depending on the model.

### Suggested Minimum Slope To Ensure Correct Drainage

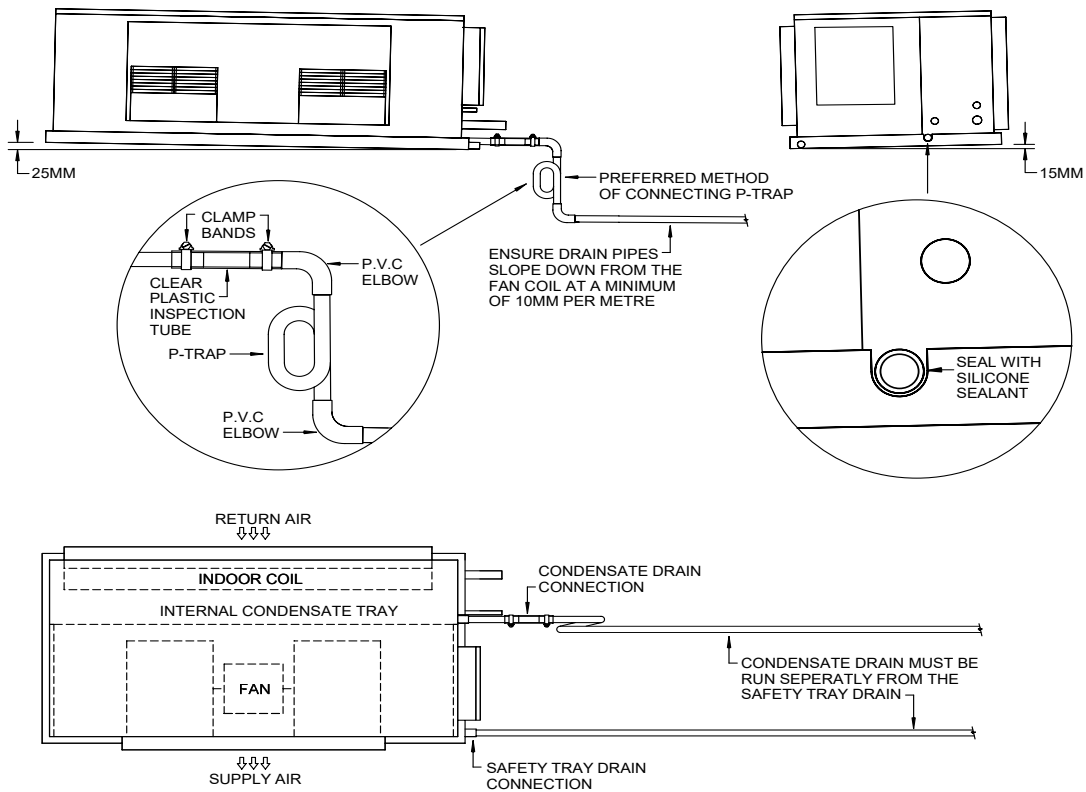

### Suggested P-Trap Connection With Limited Height Clearance

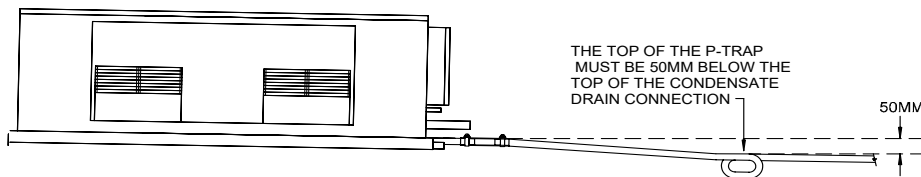

### Suggested P-Trap Connection With Long Drain Runs

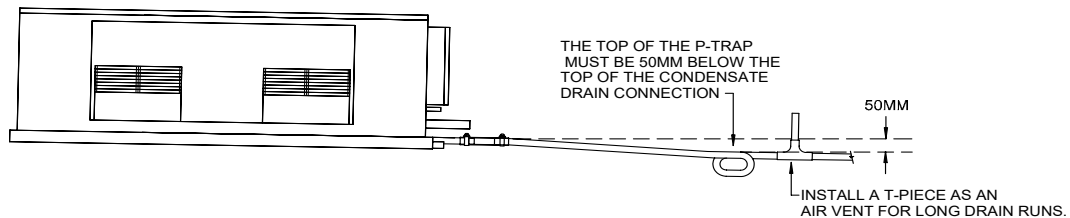

## Electrical Installation

All electrical work must be carried out by a qualified technician. Make sure all wiring is in accordance with local wiring rules. Wiring connections should be made in accordance with the wiring diagram provided.

### DANGER

#### Live Electrical Supply !

- During installation of your air conditioning unit, it may be necessary to work in close proximity to live electricity. Only qualified technicians are allowed to perform these tasks.
- Follow all electrical safety precautions when exposed to live electrical components.
- Always make sure that all power supply, including remote controls, are disconnected before performing maintenance. Observe proper LOCK-OUT / TAG-OUT (LOTO) procedures to ensure that power cannot be inadvertently energised. Failure to disconnect power before maintenance procedure can result in serious injury or death.
- All electrical wiring must be in accordance with the relevant electrical authority rules and regulations.

### CAUTION

#### STATIC SENSITIVE ELECTRONIC DEVICES !

- DO NOT handle electronic devices unless you are wearing an Anti-Static Wrist Strap that is connected to a EARTH. Failure to protect the electronic devices from static electricity may cause unreparable damage.
- Static damaged electronic devices are NOT COVERED for replacement under warranty.

### Wiring Diagram

The wiring diagrams specific for your air conditioning system are located on the inside of the electrical access panel.

Always refer all wiring installation, servicing and troubleshooting of this equipment to this diagram to ensure correct electrical connections are satisfied.

### Supply and Power Requirements Procedure

It is the installer's responsibility to provide power supply wiring to the sub-mains isolator. Wiring should conform to the current electrical authority regulations and all wiring connections to be as per electrical diagram provided with the unit.

- Confirm that the power supply available is compatible with the unit nameplate ratings. The supply power must be within +10% to -6% of the rated voltage as per AS60038.
- Protect electrical service from over current and short circuit conditions in accordance with the latest edition of the AS/ NZS 3000 "Australian / New Zealand Wiring Rules". Protection devices are to be sized accordingly as per to the electrical specifications of the unit.
- Complete the outdoor unit power supply wiring into the sub-mains isolator.
- Secure the power cords and control cables that enters in/exits out the unit. Use the cable ties provided in the electrical panels.
- Provide proper unit earthing in accordance with local and national wiring rules.

## Wiring Diagram

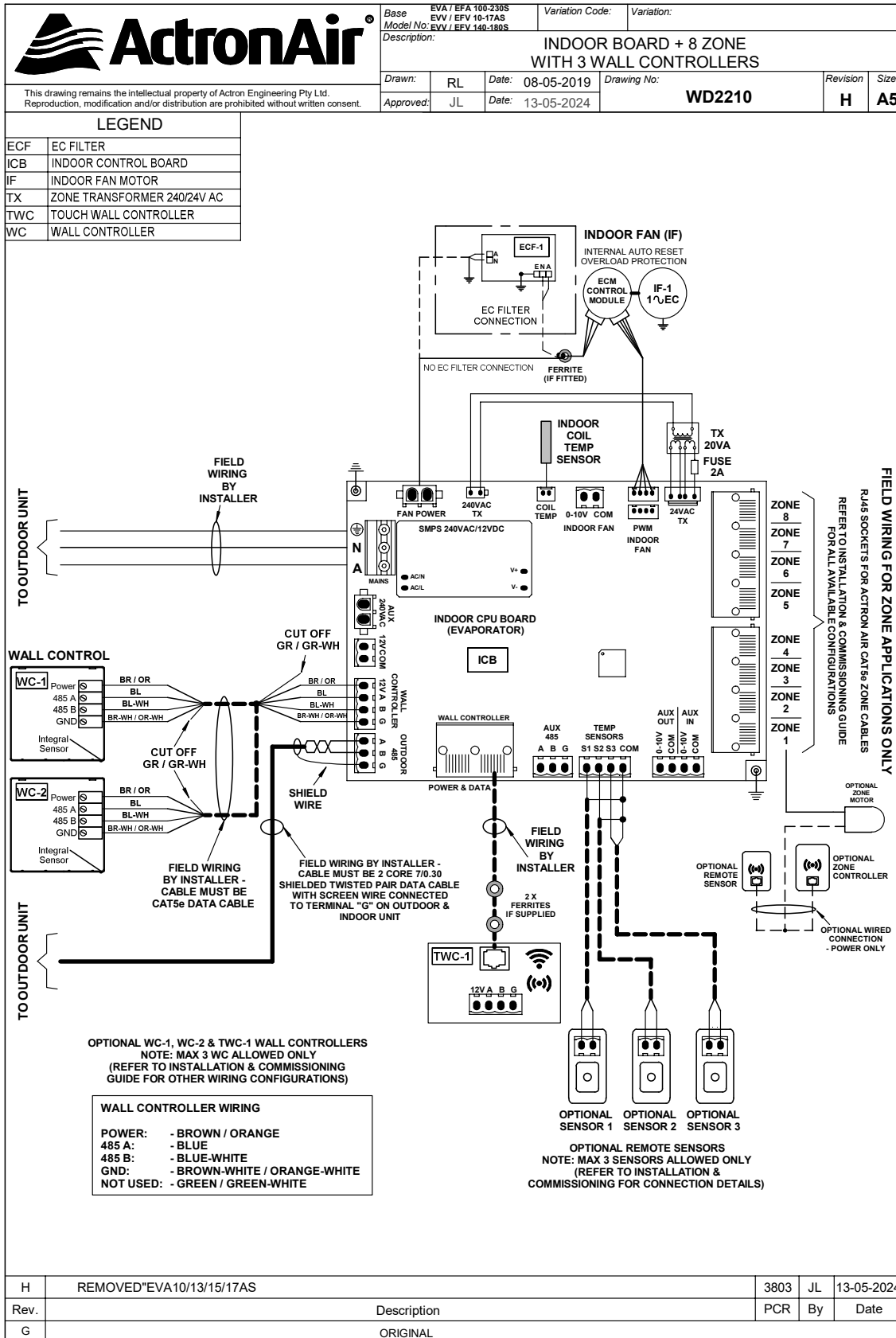

DESIGNS AND SPECIFICATIONS ARE SUBJECT TO CHANGE WITHOUT NOTICE.



## Electrical Connection

### NOTES

- To minimise noise interference, Data and Power cable clearance should be maintained as much as possible.
- All drawings are for illustration purposes only. Actual unit may vary depending on the model.

### DETAILED WIRING DIAGRAM IS PROVIDED WITH THE UNIT.

Outdoor Unit: Located at the back of electrical/compressor access panel.  
Indoor Unit: Located at the back of electrical box cover.

### SPLIT UNIT

- ① MAINS WIRING (230/400VAC)  
(Single Phase + Neutral + Earth) 50Hz  
(Three Phase + Neutral + Earth) 50Hz
- ② INTER-CONNECTING POWER CABLE (230VAC)  
(Single Phase + Neutral + Earth) 50Hz
- ..... ③ DATA CABLE TO WALL CONTROLLER  
(Cat5e UTP (AWG 24) Data Cable)
- - - - ④ EXTRA LOW VOLTAGE DATA CONTROL WIRING  
(2 Core Shielded Twisted Pair 7/0.30 (0.5mm<sup>2</sup>) Data Cable)

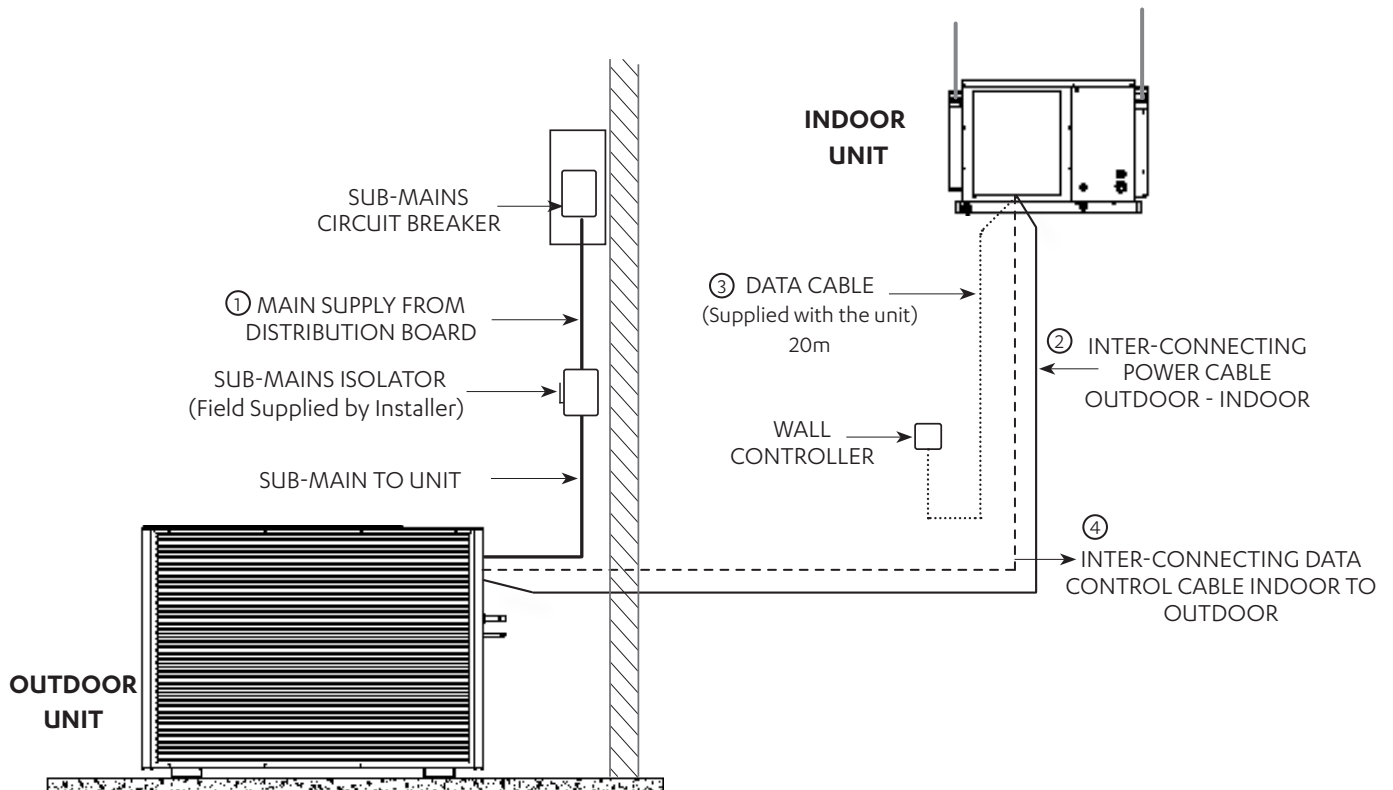

## Data Cable Shielding Instructions

**2 Core Twisted** (ActronAir Part Number: AEDC2)

### NOTES

- Maintain the twist of the core wires up to the Green Terminal Plug.
- Maximum strip length of outer insulation to the Green Terminal Plug is 50mm.
- Make sure the cable colors used for the Data Terminal in Outdoor Unit match the Data Terminal in Indoor unit.

Outdoor Unit Data Terminal (Green Plug)

“Terminal A” - White Wire

“Terminal B” - Black Wire

“Terminal G” - Shield Wire

Indoor Unit Data Terminal (Green Plug)

“Terminal A (+)” - White Wire

“Terminal B (-)” - Black Wire

“Terminal C” - Shield Wire

Insert data cable through the lower snap bushing and first cable tie on the right hand side of the electrical panel.

Connect core wires and shield wire into the Outdoor Board green terminal plug marked “INDOOR A, B and G”.

(Refer to unit wiring diagram for complete wiring connection details).

### NOTE

All drawings are for illustration purposes only. Actual unit may vary depending on the model.

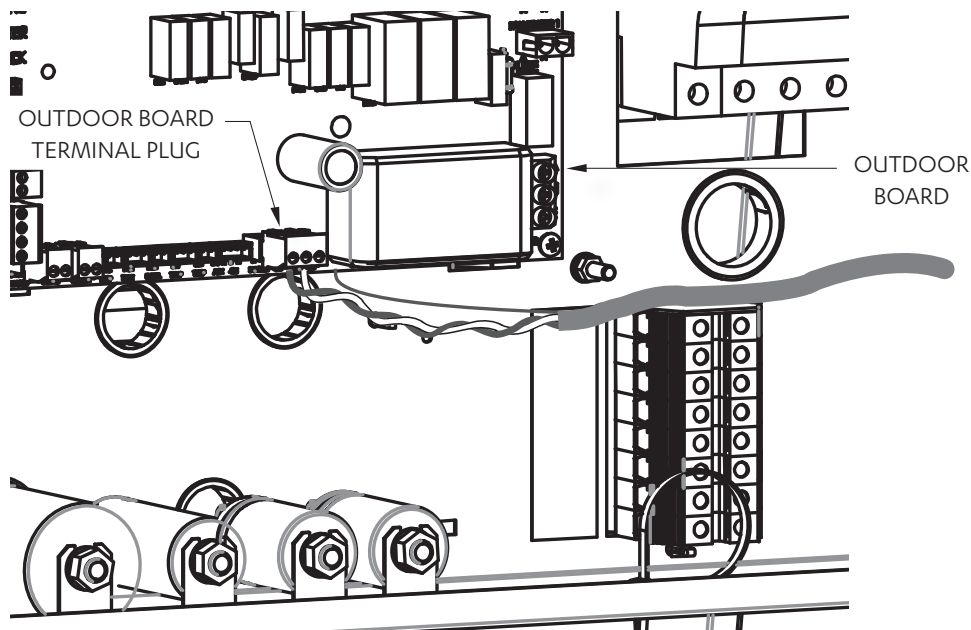

Fig. 3

## Circuit Breaker Size and Cable Size Requirement

Model	Circuit Breaker Size	Cable Size * (mm <sup>2</sup> )	
	Amps	MAIN	O.D. to I.D.
CRV140S/EVV140S	25.0	4.0	1.0
CRV160S/EVV160S	32.0	6.0	1.0
CRV180S/EVV180S	32.0	6.0	1.0
CRV160T/EVV160S	20.0	2.5	1.0
CRV180T/EVV180S	20.0	2.5	1.0
CRV210T/EVV210S	25.0	4.0	1.5
CRV240T/EVV240S	25.0	4.0	1.5

\* Suggested Minimum Cable Size should be used as a guide only, refer to AS/NZS 3000 "Australian / New Zealand Wiring Rules" for more details.

## Wall Controller Options

### Wall Controller Options

A maximum of three (3) wall controllers in the below combinations is allowed per unit. See below table.

Options	Wall Controllers		
	C1	C2	C3
1st Option	NEO		
2nd Option	NEO	NEO	
3rd Option	NEO	NEO	LR7-1 / LC7-2
4th Option	NEO	LR7-1 / LC7-2	
5th Option	NEO	LR7-1 / LC7-2	LR7-1 / LC7-2
6th Option	LR7-1 / LC7-2		
7th Option	LR7-1 / LC7-2	LR7-1 / LC7-2	
8th Option	LR7-1 / LC7-2	LR7-1 / LC7-2	LR7-1 / LC7-2

#### NOTES

- NEO - Available in White (NTW-1000) and Black (NTB-1000).
- LC7-2, LR7-1 and LM-RS-2 - Available in White and Grey.
- In the instance of a combination of NEO and LR7-1 / LC7-2 being connected together, the NEO will always need to be addressed as C1.

## Wiring Configuration : Recommended

### NOTES

- Diagram shown below is a general representation only. Refer to individual unit wiring diagram for complete wiring connection details.
- Long runs beside Mains cables or TV antenna cables should be avoided.
- Wiring configuration for LR7-1 and LC7-2 wall controller is the same.
- Daisy connection is not allowed for the NEO wall controller.
- Two Ferrite Clips\*, if supplied, are to be placed 200mm and 400mm from the NEO controller.

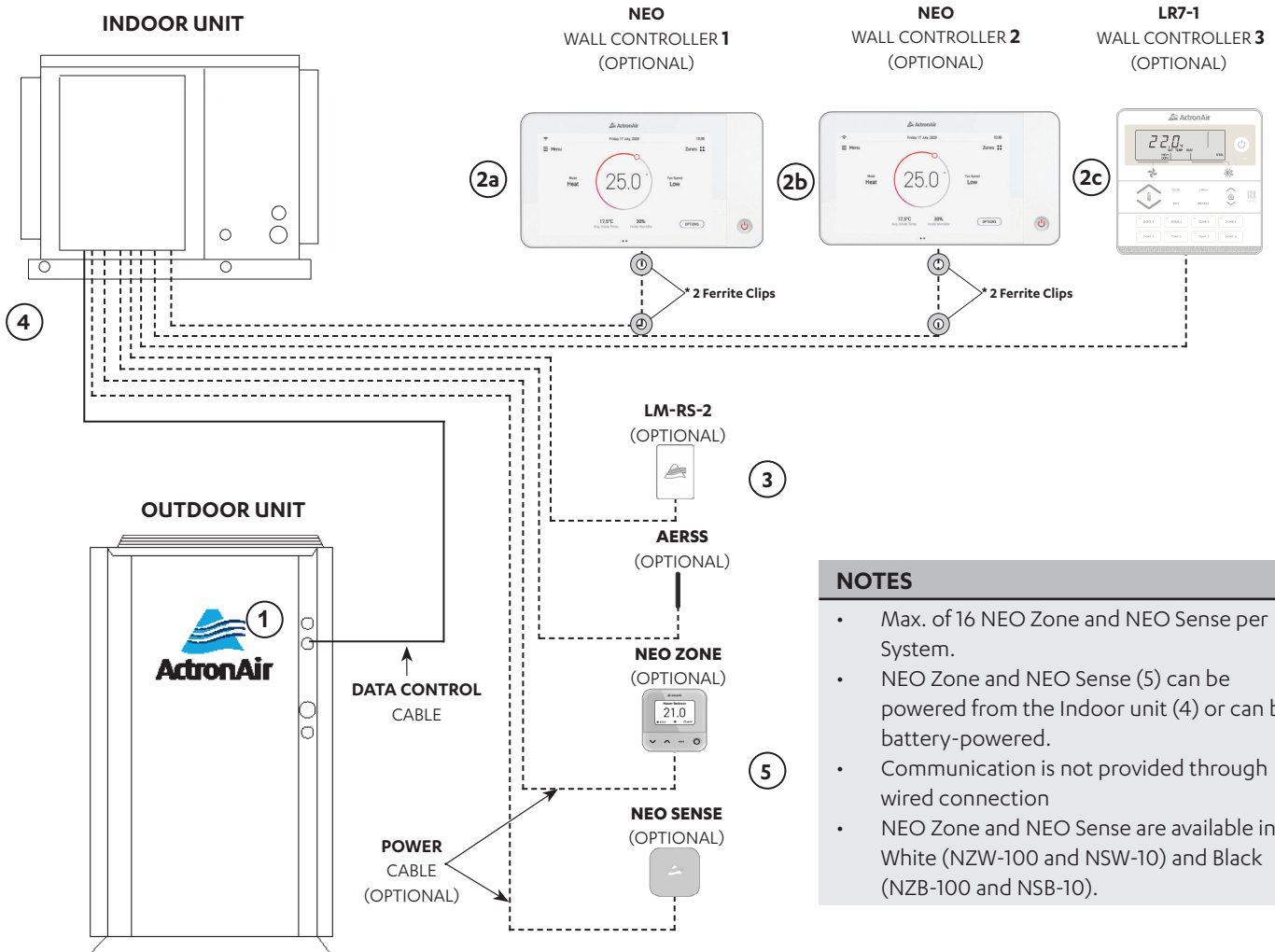

### NOTES

- Max. of 16 NEO Zone and NEO Sense per System.
- NEO Zone and NEO Sense (5) can be powered from the Indoor unit (4) or can be battery-powered.
- Communication is not provided through wired connection
- NEO Zone and NEO Sense are available in White (NZW-100 and NSW-10) and Black (NZB-100 and NSB-10).

Item	Description	Maximum Cable Length
1 to 4	Outdoor PCB to Indoor PCB	100 m
4 to 2a, 4 to 2b	Indoor PCB to Wall Controller	90 m
4 to 2c	Indoor PCB to Wall Controller 3	100 m
4 to 3	Indoor PCB to Remote Sensor	100 m
4 to 5	Indoor PCB to ZC and ZS	100 m

Description	Cable Type
Indoor to Wall Controller	Cat5e UTP (AWG 24) Data Cable
Indoor to Remote Sensor	Cat5e UTP (AWG 24) Data Cable
Indoor to Outdoor Data Cable	2 Core (1 Pair) Twisted Pair, 7/0.30 (0.5mm <sup>2</sup> ) Shielded Data Cable

**Wiring Configuration : Alternate**

**NOTES**

- Diagram shown below is a general representation only. Refer to individual unit wiring diagram for complete wiring connection details.
- Long runs beside Mains cables or TV antenna cables should be avoided.
- Wiring configuration for LR7-1 and LC7-2 wall controller is the same.

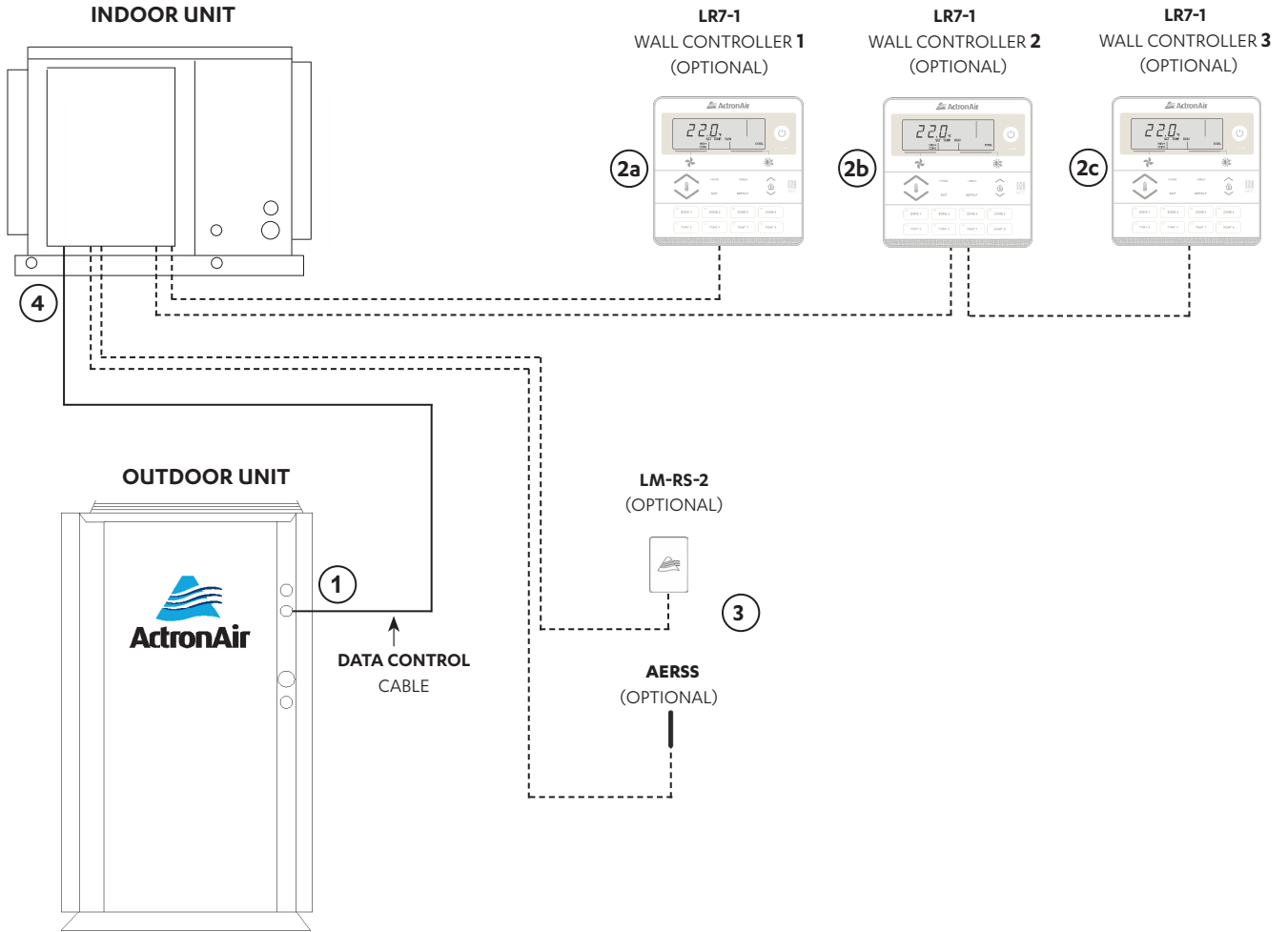

Item	Description	Maximum Cable Length
1 to 4	Outdoor PCB to Indoor PCB	100m
4 to 2a	Indoor PCB to Wall Controller 1	100m
4 to 2c	Indoor PCB to Wall Controller 3 (last controller)	75m total (Daisy Chain)**
4 to 3	Indoor PCB to Remote Sensor	100m

\*\* Maximum Daisy Chain connection is up to 2 wall Controllers.

Description	Cable Type
Indoor to Wall Controller	Cat5e UTP (AWG 24) Data Cable
Indoor to Remote Sensor	Cat5e UTP (AWG 24) Data Cable
Indoor to Outdoor Data Cable	2 Core (1 Pair) Twisted Pair, 7/0.30 (0.5mm <sup>2</sup> ) Shielded Data Cable

## Cable Length - Zoning

### Neo Zone Controller / Neo Zone Sensor

#### NOTES

- All drawings are for illustration purposes only. Actual unit may vary depending on the model.
- Refer to individual unit wiring diagram for complete wiring connection details.
- \* All Zone Device Power Cable : Cat5E Spec Cables with RJ45 Connectors and Cable Boots - Green Colour
- \*\* Total Cumulative length of all the aggregate cable must not exceed 250 meters. Consult ActronAir for longer cable length requirement.

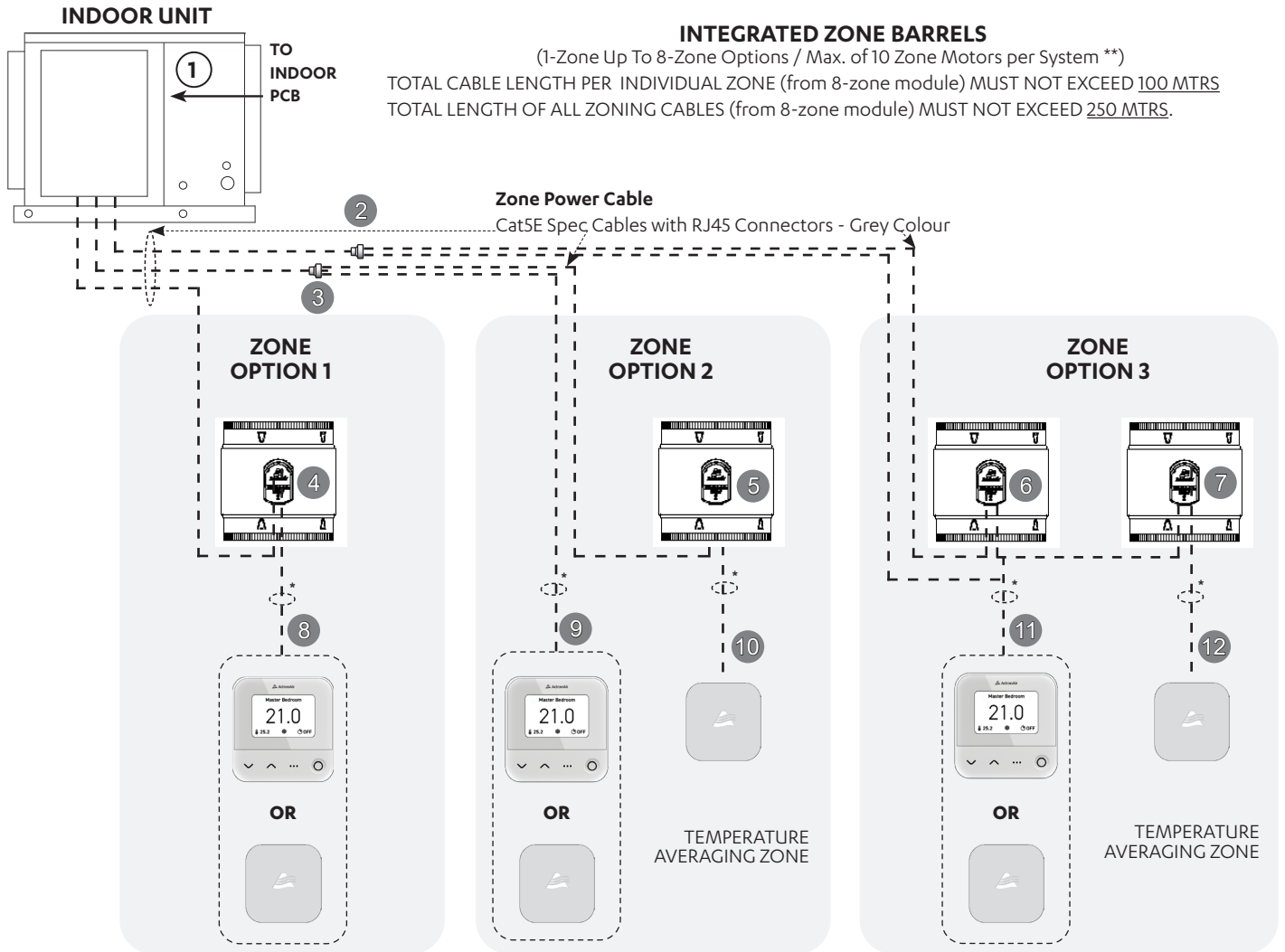

ITEM	DESCRIPTION	MAXIMUM CABLE LENGTH
1 to 2 1 to 3	8-zone module to 3-way cable joiner (P.N. 4070-012)	0.175m
1 to 8	8-zone module to zone controller	100m
4 to 8 5 to 10 7 to 12	zone barrel motor to zone device	50m
3 to 9 2 to 11	3-way cable joiner to zone device	50m

## LR7-1 / LR7-2

### NOTES

- All drawings are for illustration purposes only. Actual unit may vary depending on the model.
- Refer to individual unit wiring diagram for complete wiring connection details.

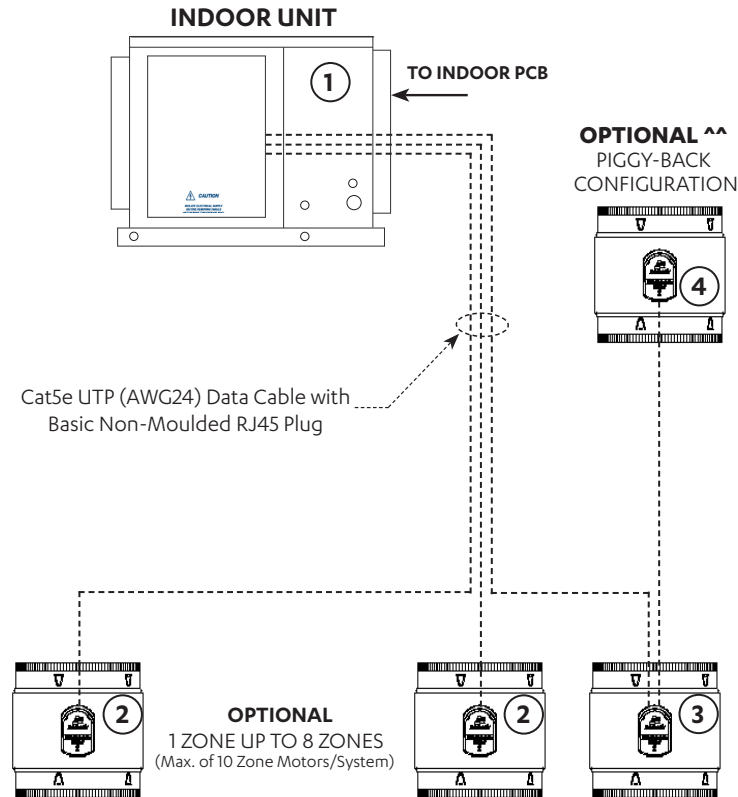

Item	Description	Maximum Cable Length * ^
1 to 2	Indoor PCB to Zone Barrels	100m
1 to 4	Maximum Cumulative Cable Length** (per zone - 8 zone)	100m
3 to 4	Zone Barrel 3 to Zone Barrel 4*** (Piggy Back)	95m

#### \* Suggested Maximum Cable Length

Long runs beside Mains cables or TV antenna cables should be avoided where possible.

\*\* Maximum Cumulative Cable Length per individual zone must not exceed 100 m per zone.

1 to 4 (Optional 4 Zones Piggy-Back Configuration), if 1 to 3 is 75m, then 3 to 4 must be 25m to make a total of 100m.

\*\*\* Recommended maximum cable length, providing total of preceding cable connections are only 5m.

^ **Total Cumulative length of all the aggregate cable must not exceed 500 meters.** Consult ActronAir for longer cable length requirement.

^^ 10 Zone Barrels are allowed and a maximum of 4 Zone Barrels are allowed per individual zone.



## Wiring Connections

### LR7-1 and LC7-2 Wall Control Wiring Connections

#### WALL CONTROL WIRING

POWER: - BROWN / ORANGE  
 485 A: - BLUE  
 485 B: - BLUE-WHITE  
 GND: - BROWN-WHITE / ORANGE-WHITE  
 NOT USED: - GREEN / GREEN-WHITE

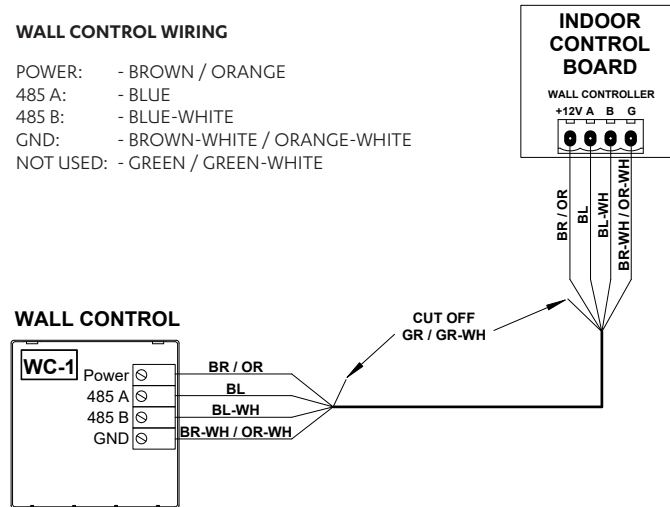

### NEO Wall Control Wiring Connections

#### NOTES

Two FERRITE CLIPS, if supplied, should be installed 200 mm away and FERRITE 2 should be 400 mm away from the Wall Control.

#### NEO Hard Wiring

#### WALL CONTROL WIRING

POWER: - BROWN / ORANGE  
 485 A: - BLUE  
 485 B: - BLUE-WHITE  
 GND: - BROWN-WHITE / ORANGE-WHITE  
 NOT USED: - GREEN / GREEN-WHITE

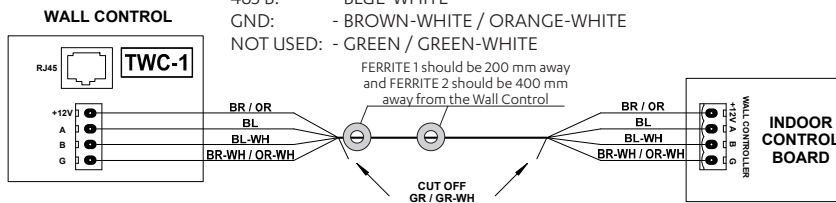

#### NEO RJ45 Wiring

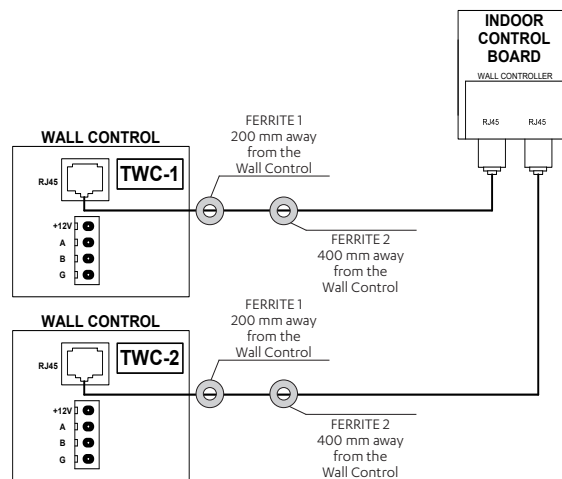

### LM-RS-2 Optional Sensor Wiring Connections

**REMOTE SENSOR WIRING**

- PAIR 1: - BLUE / BLUE-WHITE
- PAIR 2: - ORANGE / ORANGE-WHITE
- PAIR 3: - GREEN / GREEN-WHITE
- PAIR 4: - BROWN / BROWN-WHITE

**NOTE:**

- PAIR 1 AND 2 USED FOR ILLUSTRATION PURPOSES ONLY.
- CUT OFF AND TERMINATE ANY UNUSED PAIRS TO ENSURE NO WIRING IS LEFT EXPOSED.

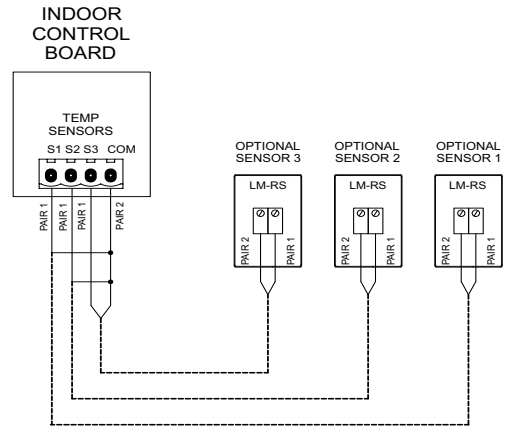

### AERSS Optional Duct Sensor Wiring Connections

**REMOTE SENSOR WIRING**

- PAIR 1: - BLUE / BLUE-WHITE
- PAIR 2: - ORANGE / ORANGE-WHITE
- PAIR 3: - GREEN / GREEN-WHITE
- PAIR 4: - BROWN / BROWN-WHITE

**NOTE:**

- PAIR 1 AND 2 USED FOR ILLUSTRATION PURPOSES ONLY.
- CUT OFF AND TERMINATE ANY UNUSED PAIRS TO ENSURE NO WIRING IS LEFT EXPOSED.

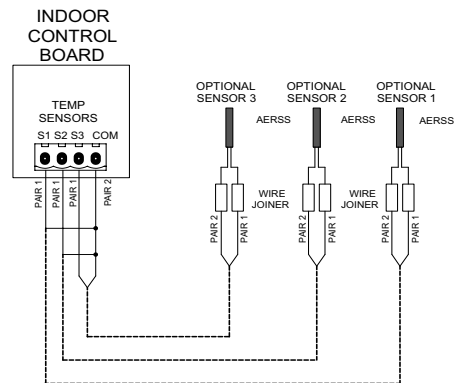

## Indoor Commissioning Guide

Before activating the self-learn mode, ensure the following:

1. System should be in the OFF mode.
2. Ensure all connected zones are able to be turned on. If a connected zone cannot be opened, refer to Troubleshooting guide for more information.
3. Check the following:
  - Return air filter, box and grille are properly installed.
  - All doors or any other restrictions that may obstruct the air path back to the return and grille are open.
  - Adjustable outlets should be in open position and System Air Balance should be complete.

Initiating Self-Learn Mode (LR7-1 or LC7-2 Wall Control)

1. Press and hold the **FAN** button and **ON/OFF** button for 5 seconds or until the word **Lrn** appears on the display and release.
2. Press the **FAN** button once and release.
3. During operation of self-learn mode, **AUTO** will flash on the controller display.

### NOTES

- If a self-learn passes **PAS** will display on the wall control.
- If a self-learn fails, **FAL** will display on the wall control. Refer to service manual for troubleshooting.
- To return to Main Menu, press the **EXIT** button.
- To cancel Self-learn Mode, press **ON/OFF** button or press the **EXIT** button.

### Self-learn process for NEO Wall Controller

Follow the commissioning process in the NEO wall controller to complete self-learn.

### NOTES

- Self-learn Mode should be activated when there are no obstructions in duct system layout.
- Whenever system duct layout will be changed, self-learn mode should be reactivated. This will allow the controller to learn the new duct layout.

## Zone Commissioning

When the unit is powered on, zone detection will automatically start. This will take 2 minutes to complete. A zone detection can also be manually triggered on the LR7-1/LC7-2 controller by pressing the **ON/OFF** button and **Zone 1** button for 3 seconds. If a zone detection is triggered manually, all the Zone LED lights will flash until the zone detection is complete.

If the zone cannot be toggled between open and closed after zone detection is complete, the zone has not been detected. Therefore; zone motor connections and motor will need to be further inspected.

### Automatic zone configuration:

Once the power will reset, Inzone Board will perform the automatic zone detection in three possible installed ways:

#### Case 1: Single zone system (No zone barrel connected)

- All zones should appear as OFF in Wall Control Menu 14.
- Last Zone Protection will be disabled
- All wall control zone lights are OFF.

#### Case 2: Multi zone system (Only zones motors no common zones)

- Only detected zones should appear to be ON, in Wall Control Menu 14.
- Last Zone Protection will be enabled for zone 1 only (unless changed from the Wall Control).
- Only detected zones are toggleable.

#### Case 3: Multi zone system (Common zones and zone barrel)

- Plug zone motors into InZone Board, skipping the number of ports required for common zones. E.g. for a system with 2 common zones and 2 zone motors, plug the zone motors into Zone 3 and Zone 4.
- The Common zones shall appear open but are not toggleable.
- Other zones other than common zones follow the same functionality as the zone motors above.
- User can also assign the sensor to the common or dump zones.

### Manual zone detection:

**Activation:** Hold the **ON/OFF** button and **Zone 1** for 3 seconds.

When zone detection is manually performed all zone lights will flash.

### NOTES

- If **Zone 1** is not detected then zone light will always be ON and will not be allowed to toggle.
- Other than **Zone 1** if any other zone is not detected, then wall control light will remain OFF.
- The unit will remain in standby during a zone detection. After a zone detection is complete, the unit will resume operation in its previous mode.

## Maintenance Frequency Checklist

Regular servicing of equipment by a qualified technician is recommended every 12 months for residential applications and every quarter for commercial applications. Regular servicing of your unit helps in maintaining its optimum performance and reliability. **The following checklist and service periods are provided as a guide only, as some sites may require more frequent servicing.**

ELECTRICAL											
Parts	Service Period					Detail of Service Check	Service Methods				
	1 Mth	3 Mth	6 Mth	1 Yr	2 Yrs			3 Yrs	4 Yrs	5 Yrs	
Printed Circuit Boards				✓						Visual Inspection	Tighten Terminals as necessary on printed circuit boards
Electrical Connections				✓						Check all electrical terminals, mains, communications, etc	Re-tighten if loose.

INDOOR UNIT											
Parts	Service Period					Detail of Service Check	Service Methods				
	1 Mth	3 Mth	6 Mth	1 Yr	2 Yrs			3 Yrs	4 Yrs	5 Yrs	
Casing / Panels and Frames				✓						Visual check for damage, rust and dust accumulation.	For highly corrosive environment, wash panels quarterly with water and neutral detergent solution. Wax panels. Repair / re-paint where required.
Insulation				✓						Visual check for insulation conditions.	Repair / replace insulation material.
Fan				✓						Visual check for run out of balance and dust attached	Clean off dust as necessary to negate possibility of fan running out of balance
Motor				✓ Ω						Visual check on wiring. Insulation resistance check to be carried out annually	Measure insulation resistance. Reading should be more than 1MΩ.
Heat Exchanger				✓						Check for clogging by dust. Check for leaks / damage.	Clean air inlet side as necessary. Straighten any bent fins using fins comb.
Drain Pan/ Condensation line				✓						Check for obstructions and free flow of water	Clean to eliminate obstructions/ sludge and check condition of pan. Pour water to ensure flow
Filter*		✓								Check for clogging by dust.	Clean Filter
Temperature Readings				✓						Measure air on and air off	Place temperature probe in return and supply air of unit.
Damper Motors (if fitted)				✓						Visual inspection of motors open/closing. Ensure no obstructions	Drive motors opened and closed. Ensure correct operation
Duct Works				✓						Inspect duct works for air gaps.	Re-tape any loose ducts.

\* Service period for filter cleaning may vary depending on operating time and surrounding environment.

## Version History

DOCUMENT VERSION	BOM VERSION	UPDATE HISTORY
Ver 2	-0100	Released
Ver 3	-0100	Updated the WD and Wiring Connections with Ferrite Clips and Neo Zone and Neo Sense.
Ver 4	-0100	Updated WD
Ver 5	-0100	Added Safety Precautions Information



©Copyright 2020 Actron Engineering Pty Limited ABN 34 002767240. ®Registered Trade Marks of Actron Engineering Pty Limited. ActronAir is constantly seeking ways to improve the design of its products. Therefore, specifications are subject to change without notice.

Installation and Commissioning Guide - Advance R-410A Split Ducted Indoor Unit  
Doc. No.0525-084 Ver. 5 240813