

ADVANCE

Split Ducted Unit

Installation and Commissioning Guide - Outdoor Units (R-410A)



Model Numbers

CRV140S
CRV160S
CRV180S
CRV160T
CRV180T
CRV210T
CRV240T

IMPORTANT NOTE:

Please read this manual carefully before installing or operating your air conditioning unit.



Table of Contents

Introduction	4
General Information	5
Safety Instructions	7
Installation Information	8
Operation Manual Access	9
Components Overview	10
Control Panel	11
Single Phase (CRV140-180S)	11
Three Phase (CRV160-240T)	11
Unit Dimensions and Clearances	12
CRV140S	12
CRV160S / CRV160T / CRV180S / CRV180T	13
CRV210T / CRV240T	14
Unit Lifting Procedure	15
Outdoor Unit Preparation	17
Field Pipe Connection	19
Piping and Brazing	19
Pressure Testing	22
Evacuation Procedure (Triple Evacuation)	22
Electrical Installation	24
Electrical Connection	25
Split Unit	25
Wall Controller Options	26
Wall Controller Options	26
Wiring Configuration : Recommended	27
Wiring Configuration : Alternate	28
Wiring Connections	29
LR7-1 and LC7-2 Wall Control Wiring Connections	29
NEO Wall Control Wiring Connections	29
LM-RS-2 Optional Sensor Wiring Connections	30
AERSS Optional Duct Sensor Wiring Connections	30
Data Cable Shielding Instructions	31
Circuit Breaker Size and Cable Size Requirement	32
Demand Response Management	33
Configuring and Commissioning Setup	34
Menu and Navigation	34
Configuring Compressor and Capacity(cnFg)	34
Configuring Control Source (CtrS)	34

Table of Contents

Third Party Control Input (Indoor and/or Outdoor Board)	36
0-10V Analogue Input for Compressor and Indoor Fan	36
0-10V Analogue Input for Compressor with Fixed Indoor Fan Speed	37
Input for Fixed Compressor with Fixed Indoor Fan Speed	38
0-10V Analogue Input for Indoor Fan with Fixed Speed Compressor	38
Run and Fault Indication Output (Outdoor Board)	39
Remote On/Off	40
Indoor Fan Commissioning	41
EVV140S / EFV140S	41
EVV160S / EFV160S	44
EVV180S / EFV180S	47
EVV210S / EFV210S	50
EVV240S / EFV240S	53
Refrigerant Charging	56
Specifications for Refrigeration	60
Maintenance	62
Maintenance Frequency Checklist	64
Version History	65

Introduction

CONGRATULATIONS on your purchase of an ActronAir air conditioning system! This unit has been designed and engineered to provide optimum air conditioning and to achieve maximum energy efficiency.

Your air conditioning system has been manufactured from the highest quality materials. Numerous “in house” and “external” inspection and test procedures were conducted to your air conditioner to ensure satisfactory operation.

Information About This Guide

This guide provides installation instructions, specific to your split ducted unit. Read this manual thoroughly and take into consideration all specifications and instructions to ensure correct installation and safe operation of your air conditioning system.

NOTE

Print a copy of this document and keep it for future reference. Ensure all technicians that work on the unit can refer to this manual at any time.

Product Inspections

Check your air conditioning unit and all items against the invoice upon receiving your shipment. Inspect the unit, components and accessories for any sign of damage. If there is any damage to the unit, contact ActronAir Customer Care Department immediately on: **1300 522 722** to obtain a Goods Return Number.

Check the unit nameplate to verify the model, serial number, electrical rated specifications are correct.

Codes, Regulations And Standards

The installer and/or contractor assumes responsibility to ensure that unit installation complies with the relevant council, state / federal codes, regulations and building code standards. All electrical wiring must be in accordance with current electrical authority regulations and all wiring connections to be as per electrical diagram provided with the unit

General Information

The ActronAir Advance Series Ducted air conditioning units are designed for applications where superior performance, high efficiency, reliability, supply air quality and quiet operation are the prime priorities. The units are built with the latest technology, inverter scroll compressor, EC indoor fans, low-noise outdoor fans and an intelligent electronic control.

For optimum efficiency, your air conditioning unit will deliver just the right amount of cooling or heating capacity you demand. Even in extreme conditions, the unit will still supply the required demand at peak performance.

Energy Efficient Refrigeration Circuits

The ActronAir system is designed with a split ducted refrigeration circuit that delivers only the amount of cooling or heating actually required to maintain your desired comfort at the most optimum efficiency.

Each refrigeration circuit consists of:

- High efficiency variable capacity scroll compressor with individual compressor drive.
- Hydrophilic coated condenser coil designed for optimum performance and efficiency with corrugated fins and ruffled tubing.
- Hydrophilic coated evaporator coil designed for optimum performance and efficiency with lanced fins and ruffled tubing.
- Electronic expansion valve (EEV), to maintain efficiency at different operating conditions.

Evaporator Section

The evaporator section has EC fans which deliver just the right amount of airflow, depending on requirements. The fans provide superior performance for your comfort at optimum efficiency:

- Highly efficient variable speed EC motor that uses less energy than the traditional air conditioner.
- Easy variable indoor fan commissioning via intelligent controllers.
- Low noise operation.

Condenser Section

Uses two (2) axial fans and a state of the art inverter scroll compressor, with the following features:

- Efficient Tru-Inverter Compressor and Inverter Drive combination.
- Efficient axial fans with direct drive AC motor.
- Low noise operation.

Electrical Section

The electrical section is composed of a separate panel for controls, protecting the components from the elements.

Durable Design and Construction

ActronAir is an Australian manufacturer with proven high quality air conditioning products. Known for their durability and reliable performance, these products are designed and built to withstand the extreme weather conditions.

The galvanized steel cabinet, with powder coated epoxy enamel finish, resists the toughest conditions. The louvered outdoor coil guard protects the condenser coil from any potential damage brought by hail, stones and other solid objects that may be projected to the unit.

Blue Coat Coil Protection heat exchangers ensures an enhanced heat transfer with increased performance efficiency.

System Flexibility

The ActronAir Advance series of air conditioning units are the first choice for residential, office, schools and other air conditioning facilities applications, both for new construction or retrofitting projects.

Refrigerant Handling and Accountability

ActronAir strongly urges that all service technicians make every effort to eliminate and/or vigorously reduce the emission of refrigerants to the atmosphere. Everyone must act in a responsible manner to conserve refrigerants.

Sustainability and Environmentally Friendly

The air conditioning system is supplied with zero ozone depleting R-410A refrigerant, which has no phase out or replacement concern.

With cooling and heating performance capacity that are among the best in the market, the ActronAir air conditioning units provide the solution for the reduction of energy consumption, CO₂ emission, high fuel dependency and high network grid demand.

Safety Instructions

- Only licensed HVAC technicians* should install and service air conditioning equipment. Improper service or alteration by an unqualified technician could result in significant and major damage to the product or property which may render your warranty null and void. Such unqualified service could also lead to severe physical injury or death. Follow all safety instructions in this literature and all warning labels that are attached to the equipment.
- Prevailing WH&S regulations must be observed and will take precedence to the safety instructions contained on this manual. Safe work practices and environment must be the paramount importance in the performance of all the service procedures.
- Ensure that unit installation complies with relevant council regulations and building code standards.
- All electrical wiring must be in accordance with current electrical authority regulations and all wiring connections to be as per electrical diagram provided.
- Secure the fans against accidental contact. Beware of pinch point and sharp edges which can cause cutting injury.
- Always wear appropriate PPE, remove any dangling jewellery and protect long hair by wearing a cap.
- Make sure that safety guards and panel covers are always firmly secured and not damaged before and during operation of unit.
- This appliance is not intended for use by young children or infirm persons unless they have been adequately supervised by a responsible person to ensure that they can use the appliance safely. Young children should be supervised to ensure that they do not play with the appliance.
- Installer must incorporate a means of electrical disconnection (isolator) in the sub mains fixed wiring in accordance with the latest edition of the AS/NZS 3000 (also known as Australian Wiring Rules).
- Secure the power cords and control cables that goes in/out the unit. Use the cable ties provided in the control box.

*Qualifications required will be appropriate Electrical, Refrigeration and Refrigerant Handling License and Training dependent on local State/Territory regulations.

DANGER

Hazardous Voltage - Risk of Electrocutation.

TURN-OFF the power from main isolator before proceeding with any service work of the unit. Observe proper LOCK-OUT/TAG-OUT (LOTO) procedures for electrical appliances in order to prevent accidental switching-on of the power supply.

WARNING

EC Motors and Compressor Drives are fitted with high power capacitors and can have dangerous residual voltages at motor/drive terminals after power has been isolated. Wait at least 5 minutes after power isolation and test for any residual voltage before beginning service work.

CAUTION

Beware of Rotating Fans !

Ensure that indoor and outdoor fans are isolated and have come to a complete stand still before servicing the equipment. Beware of pinch point and sharp edges which can cause cutting injury. Secure the fans against accidental contact. Always wear appropriate PPE and remove any dangling jewellery and protect long hair by wearing a cap. Ensure that no loose clothing can be caught / entangled in moving parts.

VISUAL INSPECTION AND WORK ASSESSMENT

Work areas and conditions must first be assessed and evaluated for any potential hazardous conditions. It is also important to be familiar with the unit parts and components before proceeding with any service task.

Installation Information

All service technicians handling refrigerant must be licensed to handle refrigerant gases.

Recover and Recycle Refrigerants

Never release refrigerant to the atmosphere! It is an offence in Australia to do so. Always recover, recycle and reuse refrigerants. When removing from the system, properly contain and identify refrigerants in its dedicated container for proper disposal and/or storage. Always consider the recycle or reclaim requirements of the refrigerant before beginning the recovery procedures. Obtain a chemical analysis of the refrigerant if necessary. For the recovered refrigerant and acceptable refrigerant quality, refer to the existing standards and regulations.

Refrigerant Handling and Safety

Consult the refrigerant manufacturer's Material Safety Data Sheet (MSDS) for information on proper handling and to fully understand health, safety, storage and disposal requirements. Use the approved containment vessels and refer to appropriate safety standards. Comply with all applicable transportation standards when shipping refrigerant containers.

Service Equipment and Recovery Procedures

Always use refrigerant reclaiming equipment in order to minimise refrigerant emissions. Use equipment and methods which will pull the lowest possible system vacuum while recovering and condensing refrigerant. Equipment capable of pulling a vacuum of less than 500 microns is required.

Do not open the system to the atmosphere for service work until refrigerant is fully removed and/or recovered. Perform refrigeration system evacuation, prior to charging, in accordance with AIRAH / IRHACE Refrigerant handling code of practice.

Let the unit stand for 1 hour and with the vacuum not rising above 500 microns. A rise above 500 microns indicates a leak from the system and a leak test is required to locate and repair any leak.

CAUTION

A leak test is always required on any repaired section of the refrigeration system.

Charge refrigerant into the system only after the equipment does not leak or contain moisture. Take into consideration the correct amount of refrigerant charge specified for the system to ensure efficient unit operations. When charging is complete, reclaim refrigerant from charging lines into an approved refrigerant container. Seal all used refrigerant containers with approved closure devices to prevent unused refrigerant from escaping to the atmosphere. Take extra care to maintain all service equipment directly supporting refrigerant service work such as gauges, hoses, vacuum pumps and recycling equipment.

INSTALLATION PREPARATION (Pre-Installation considerations)

The following items must be considered before beginning the unit installation:

- Verify the unit capacities and ratings with the unit nameplate.
- Make certain the floor or foundation is level, solid and has sufficient structural strength to support the unit and accessories weight.
- Allow minimum recommended clearances for periodic maintenance and service access.
- Allow sufficient space above the unit for the outdoor air discharge. Condenser air inlet, located on the coil side of the unit, requires sufficient airflow clearance for the optimum unit performance.
- Note the conditioned supply air and return air location. Ensure sufficient spaces are allocated for these purposes.
- For the connection and location of condensate drain in the unit, refer to the drawings and dimensions section of this manual.
- Preferably use anti-vibration rubber pads on residential units (**up to 24kW split ducted**).
 - Install anti-vibration rubber (installer to supply) under **all of the unit's feet** to help reduce noise and minimize vibration transfer through the foundation. Ensure that all anti-vibration rubbers are rated to provide stable support without impairing the unit's structural integrity.
 - Diameter or width of anti-vibration rubber's must be at least equal to the width of the actual feet to prevent deformation overtime.

- Wiring connections must be in accordance with the wiring diagram provided with the unit.
- Make sure all wirings are in accordance with local electricity authority regulations and standards.
- Do not install the unit close to an area where there is a danger of fire due to volatile, explosive, flammable and/or hazardous materials.
- Ensure that spaces around the unit are free from any obstructions for optimum unit performance.
- Installer to ensure correct size/type that main circuit breaker and cable is installed in unit sub-mains to protect the sub-mains and unit wiring.
- Installer to ensure correctly rated residual current device (RCD) is installed as per the latest edition of the AS/NZS 3000 (also known as Australian Wiring Rules).
- Secure the power cords and control cables that goes in/out the unit. Use the cable ties provided in the control box.

 **CAUTION**

This outdoor unit is designed to match only with an ActronAir indoor unit as specified in the Technical Selection Catalogue. The unit is supplied with factory charged refrigerant as stated in the Rating Label. The use other material as a refrigerant may cause explosion and/or personal injury.

Be aware of all the relevant regulations concerning the handling of refrigerant.

For units charged with R-410A

Ensure that R-410A is only charged in liquid form.

For units charged with R-32

R-32 refrigerant (CLASS A2L) is mildly flammable.

Thoroughly read and understand the accompanying R-32 Safety Guide for installation and maintenance instructions.

Installation, service, maintenance, repairs and decommissioning of this unit must be performed by a licensed HVAC technician; qualified to handle R-32 refrigerant.

Appliance shall be installed, operated and stored in a well ventilated area:

- where the room size corresponds to the room area as specific for operation.
- without continuously operating open flames (for example an operating gas appliance) and ignition sources (for example an operating electric heater).
- away from other potential continuously operating sources that known to cause ignition of R-32 refrigerant.

R-32 refrigerant is odorless if the refrigerant gas comes into contact with fire, it may emit a poisonous gas.

Operation Manual Access

Download from website

Operation manuals can be downloaded through our website shown below.

<https://www.actronair.com.au/brochures-manuals/#operating-manuals>

Components Overview

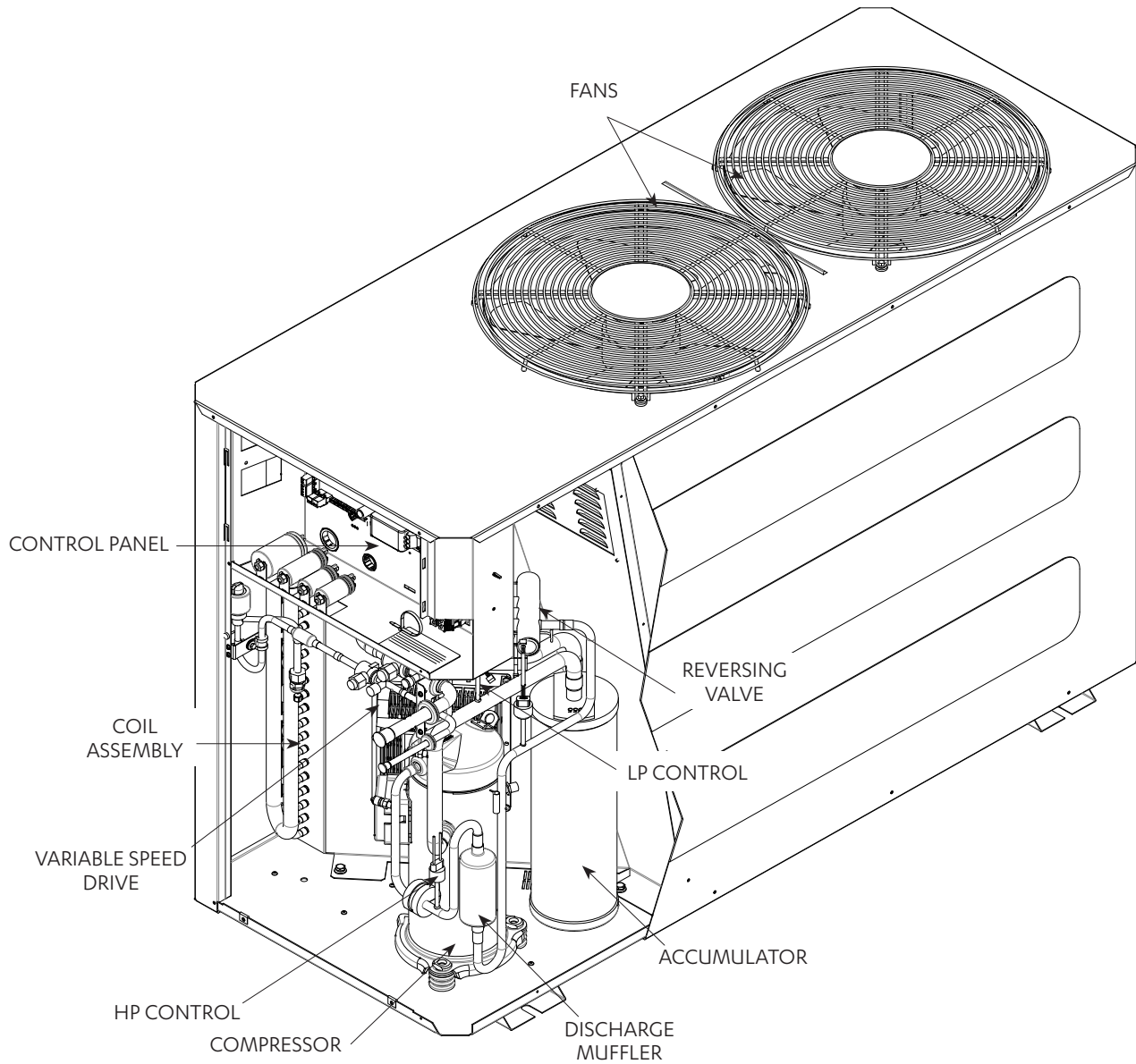

Control Panel

Single Phase (CRV140-180S)

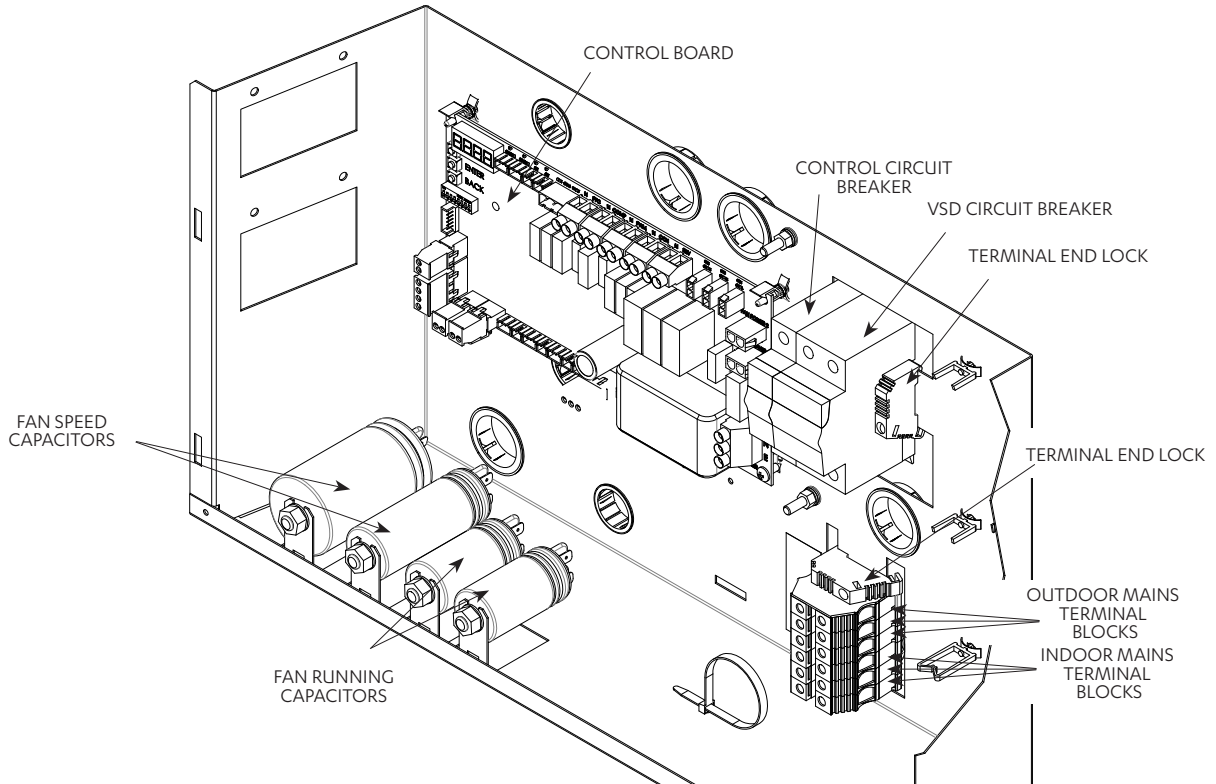

Three Phase (CRV160-240T)

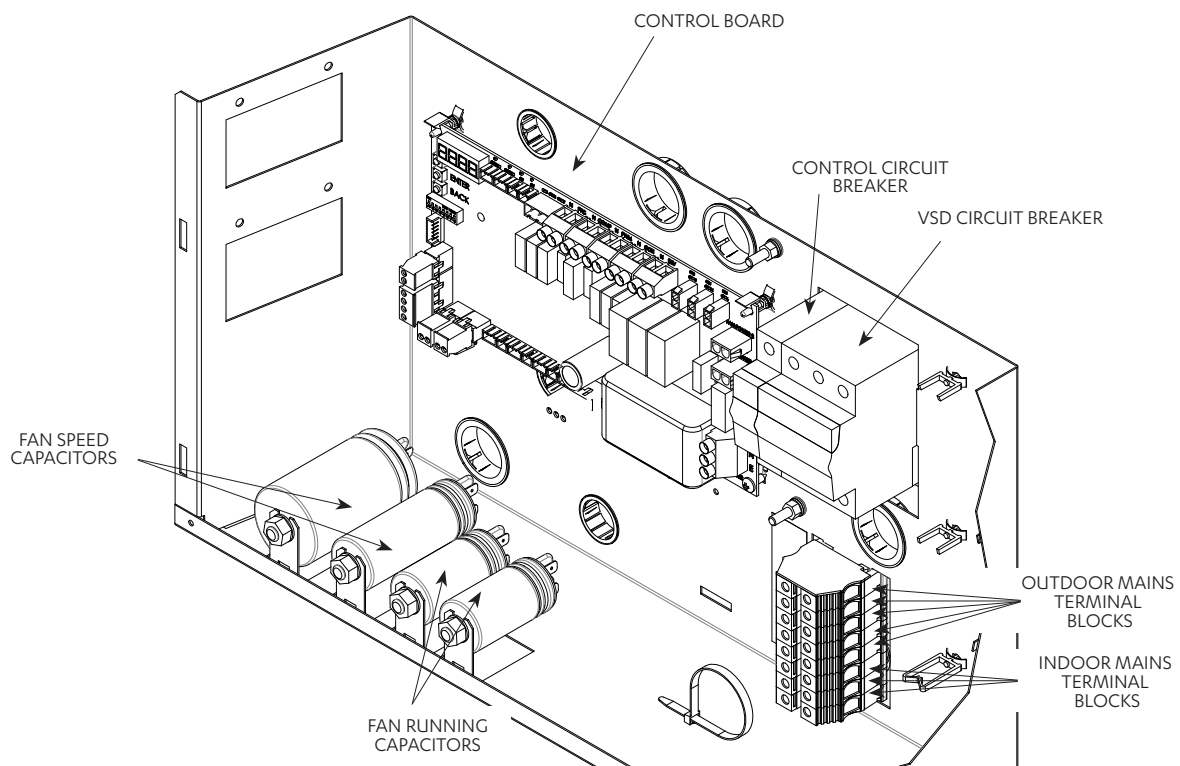

Unit Dimensions and Clearances

CRV140S

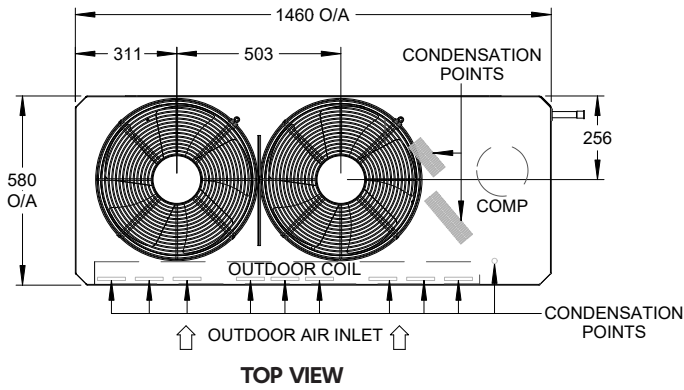

CONDENSATION POINTS ARE DESIGNED TO ENSURE ALL CONDENSATION IS REMOVED EFFICIENTLY TO AVOID WATER POOLING WITHIN THE CONDENSER. IF A SINGLE CONDENSATION DRAIN POINT IS REQUIRED, ACTRONAIR RECOMMENDS THE INSTALLATION OF A CONDENSER TRAY. THESE ARE AVAILABLE AS AN ADDITIONAL ACCESSORY.

** DRAWING IS SUBJECT TO CHANGE WITHOUT NOTICE**

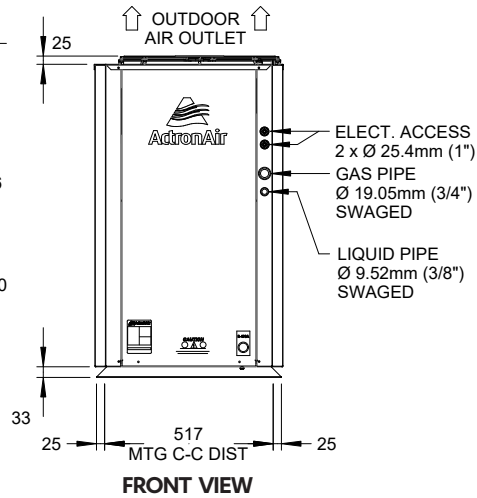
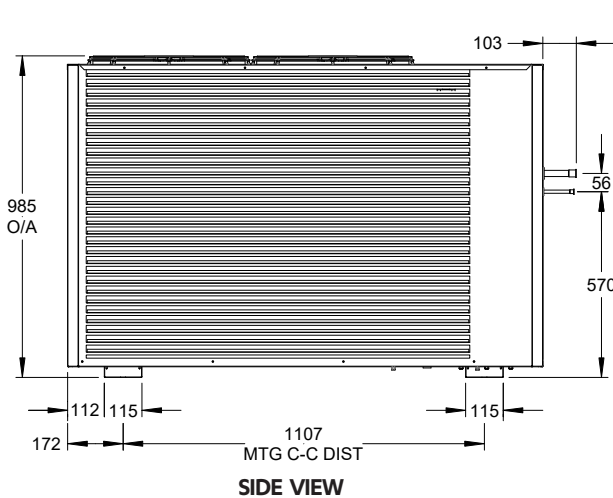

UNIT MODEL NUMBER	UNIT WEIGHT (kg)	CORNER WEIGHTS (kg)			
		A	B	C	D
CRV140S	131	21	34	28	48

MINIMUM SERVICE ACCESS AREAS AND AIRFLOW CLEARANCES

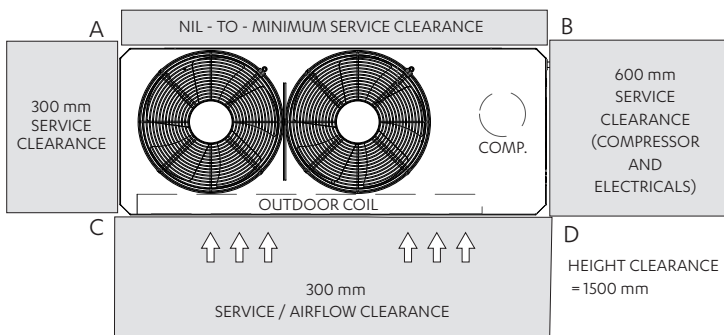

NOTES:

- Do not scale drawing. All dimensions are in mm unless specified. Refer to corresponding unit dimensional drawing for mounting hole details.
- Service Access Areas and Spaces for Airflow Clearances given are suggested minimum based on the condition that the spaces around the units are free from any obstructions and a walkway passage of 1000mm between the units or between the unit and the outside perimeter is available.
- Minimum service access areas and spaces for airflow clearances are responsibilities of the installer, ActronAir will not be held liable for any extra charges incurred due to lack of access and space for airflow.
- Under all circumstances, condenser air must not recirculate back onto condenser coil. Keep all clearance free of any obstructions.
- Maximum External Static of Outdoor Fans is 5 Pa.
- STACKING OF UNITS: Ensure that minimum airflow and clearances are met.
- Refer to pipe Connection Details on Specifications Sheet.
- MTG C-C DIST = Mounting Centre to Centre Distance.
- Use M12 bolt for feet mounting.

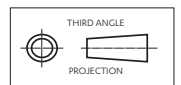

CRV160S / CRV160T / CRV180S / CRV180T

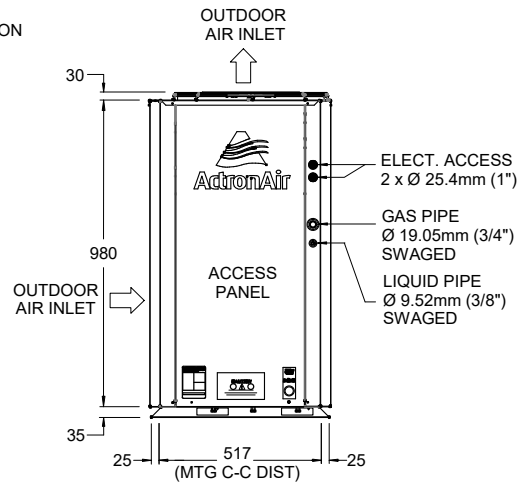
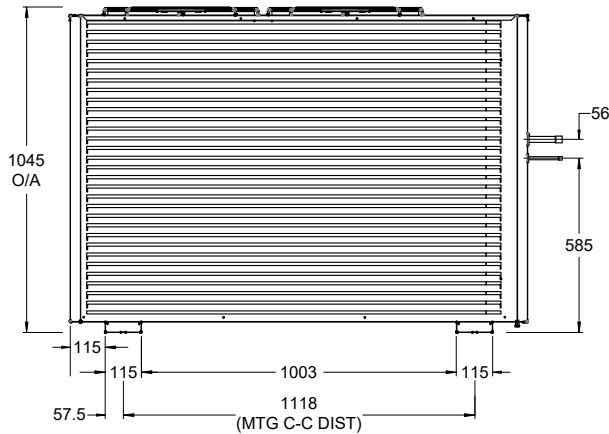
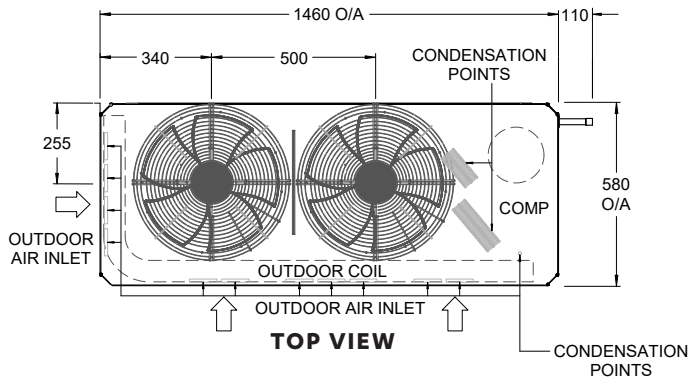

UNIT MODEL NUMBER	UNIT WEIGHT (kg)	CORNER WEIGHTS (kg)			
		A	B	C	D
CRV160S	144	22	36	34	52
CRV160T	150	22	41	34	53
CRV180S	152	22	43	34	53
CRV180T	155	23	44	35	53

MINIMUM SERVICE ACCESS AREAS AND AIRFLOW CLEARANCES

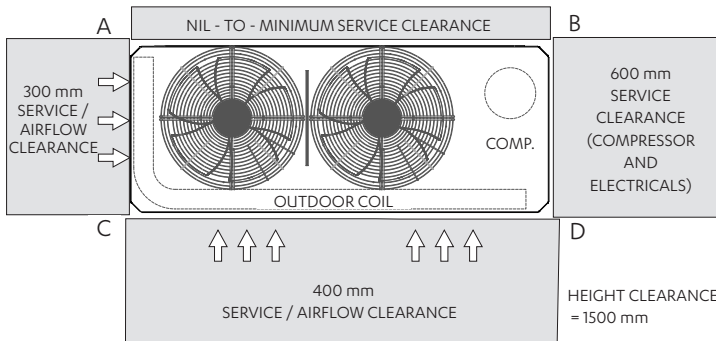

NOTES:

- Do not scale drawing. All dimensions are in mm unless specified. Refer to corresponding unit dimensional drawing for mounting hole details.
- Service Access Areas and Spaces for Airflow Clearances given are suggested minimum based on the condition that the spaces around the units are free from any obstructions and a walkway passage of 1000mm between the units or between the unit and the outside perimeter is available.
- Minimum service access areas and spaces for airflow clearances are responsibilities of the installer, ActronAir will not be held liable for any extra charges incurred due to lack of access and space for airflow.
- Under all circumstances, condenser air must not recirculate back onto condenser coil. Keep all clearance free of any obstructions.
- Maximum External Static of Outdoor Fans is 5 Pa.
- STACKING OF UNITS: Ensure that minimum airflow and clearances are met.
- Refer to pipe Connection Details on Specifications Sheet.
- MTG C-C DIST = Mounting Centre to Centre Distance.
- Use M12 bolt for feet mounting.

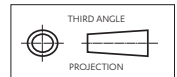

CRV210T / CRV240T

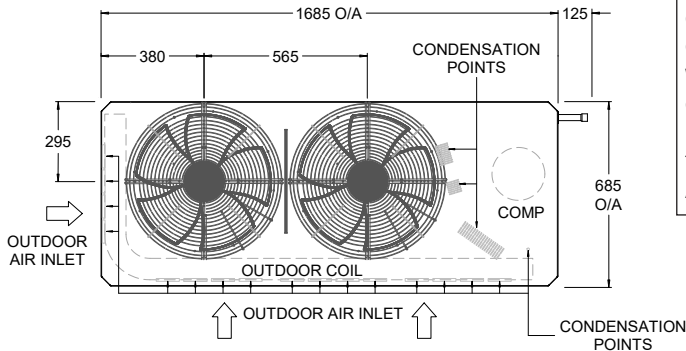

TOP VIEW

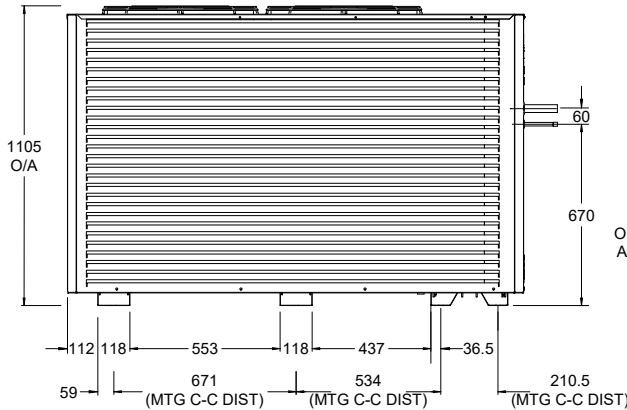

SIDE VIEW

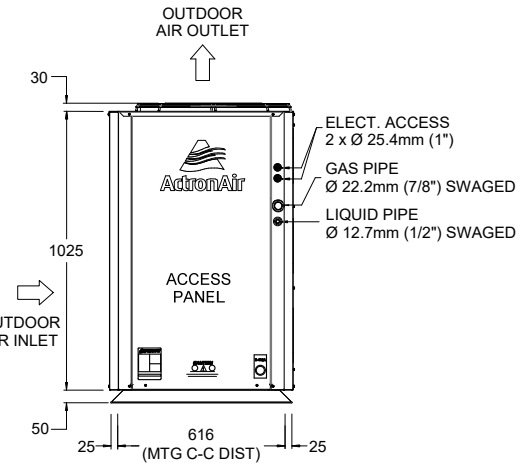

FRONT VIEW

CONDENSATION POINTS ARE DESIGNED TO ENSURE ALL CONDENSATION IS REMOVED EFFICIENTLY TO AVOID WATER POOLING WITHIN THE CONDENSER. IF A SINGLE CONDENSATION DRAIN POINT IS REQUIRED, ACTRONAIR RECOMMENDS THE INSTALLATION OF A CONDENSER TRAY. THESE ARE AVAILABLE AS AN ADDITIONAL ACCESSORY.

** DRAWING IS SUBJECT TO CHANGE WITHOUT NOTICE**

UNIT MODEL NUMBER	UNIT WEIGHT (kg)	CORNER WEIGHTS (kg)			
		A	B	C	D
CRV210T	200	27	53	48	72
CRV240T	209	28	56	51	74

MINIMUM SERVICE ACCESS AREAS AND AIRFLOW CLEARANCES

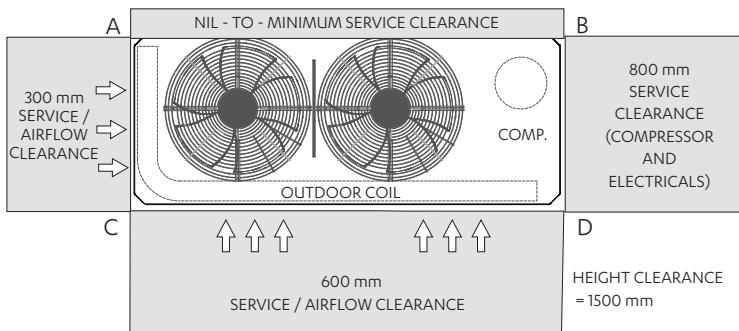

NOTES:

- Do not scale drawing. All dimensions are in mm unless specified. Refer to corresponding unit dimensional drawing for mounting hole details.
- Service Access Areas and Spaces for Airflow Clearances given are suggested minimum based on the condition that the spaces around the units are free from any obstructions and a walkway passage of 1000mm between the units or between the unit and the outside perimeter is available.
- Minimum service access areas and spaces for airflow clearances are responsibilities of the installer, ActronAir will not be held liable for any extra charges incurred due to lack of access and space for airflow.
- Under all circumstances, condenser air must not recirculate back onto condenser coil. Keep all clearance free of any obstructions.
- Maximum External Static of Outdoor Fans is 5 Pa.
- STACKING OF UNITS: Ensure that minimum airflow and clearances are met.
- Refer to pipe Connection Details on Specifications Sheet.
- MTG C-C DIST = Mounting Centre to Centre Distance.
- Use M12 bolt for feet mounting.

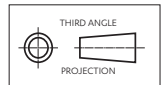

Unit Lifting Procedure

WARNING

WH&S regulations must be observed and will take precedence during lifting process.

NOTE

All drawings are for illustration purposes only. Actual unit may vary depending on the model.

Crane Lifting Method

Crane lifting method is recommended for high rise lifting.

Provide rubber pads under spreader bar to prevent damage to the unit

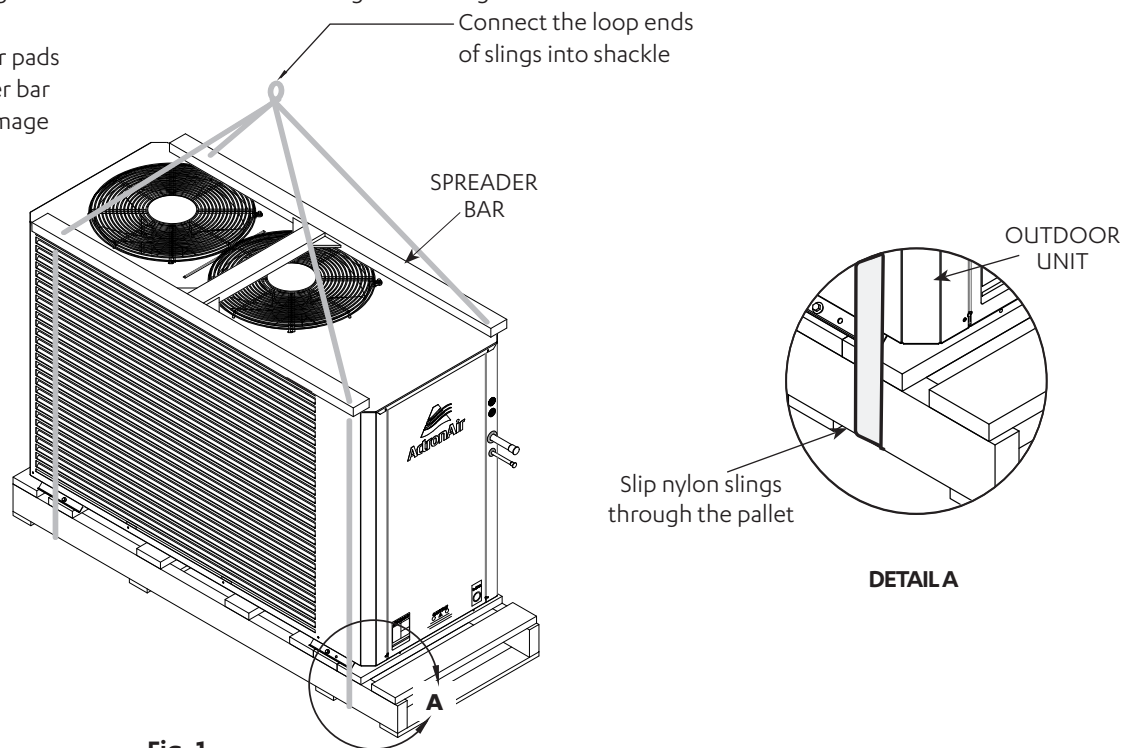

Equipment Required For Crane Lifting:

- 1 Shackle
- 2 x Nylon Slings
- Spreader bars

Refer to catalogue for unit weight before selecting shackles and slings.

NOTE

Refer to Unit Dimensions and Clearances section for unit weight before selecting shackle and slings.

Procedure:

1. Slip nylon slings through the pallet as shown in Fig. 1.
2. Use a Bow or Dee shackle to connect the slings.
3. Ensure slings are protected by rubber pads or similar if slings are draped across unit edges, corners, or air grilles . This will prevent the unit from being damaged during lifting.

4. SPREADER BARS must be used when lifting the unit.
5. Test lift the unit to determine exact unit balance and stability before hoisting it to the installation location.

Fork Lift Method

DANGER

Make sure rigging equipment, accessories and plant are sufficiently and safely capable to lift the unit in order to prevent potential damage to property, severe personal injury or death. Please check unit weight and weight distribution points as shown in the unit drawing dimensions section.

Procedure:

1. To move the unit around with a forklift, insert the fork tines through the pallet, as shown in Fig. 2.
2. Only fork the unit through compressor end or side of the unit. (See illustration for location of compressor end)

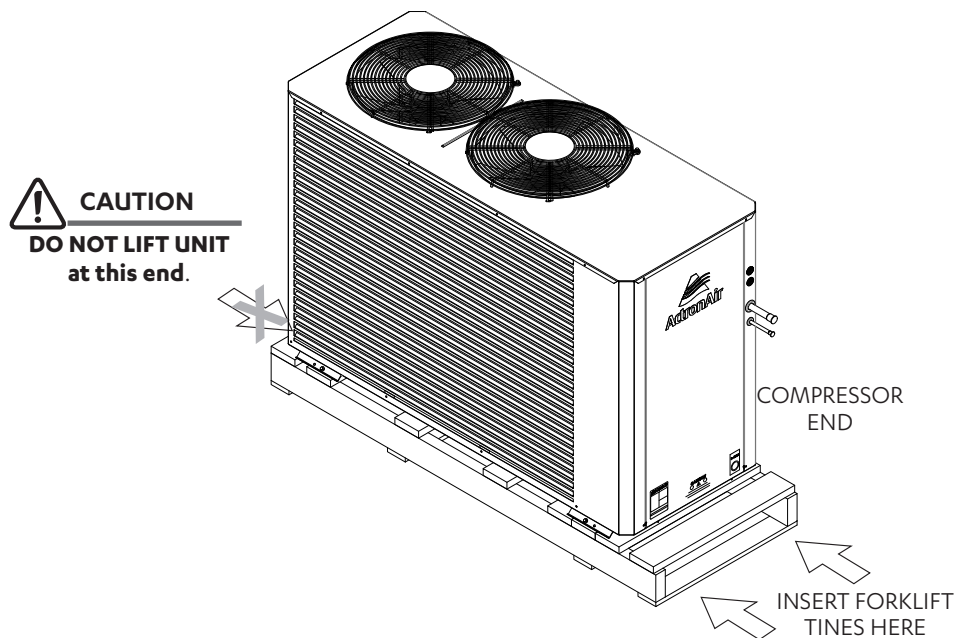

FIG.2

CAUTION

Length of fork lift tines must pass the unit middle section, in order to safely carry the unit.

Outdoor Unit Preparation

1. Remove mounting screws, as shown:

NOTES

All drawings are for illustration purposes only. Actual unit may vary depending on the model.

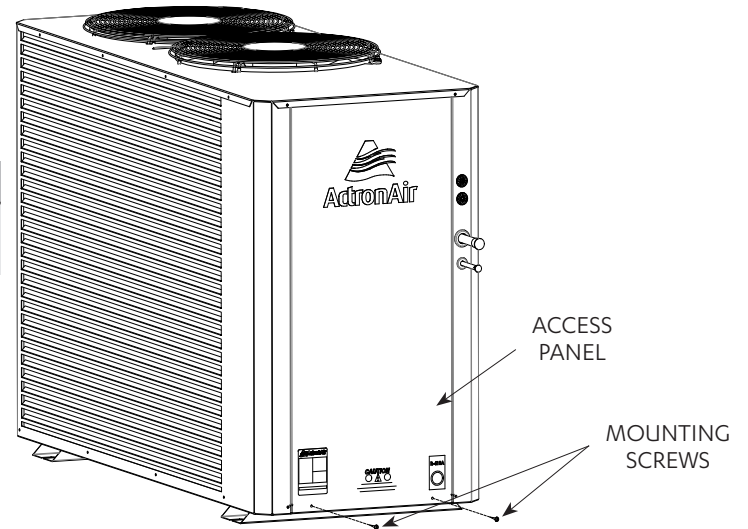

2. Remove Access Panel.

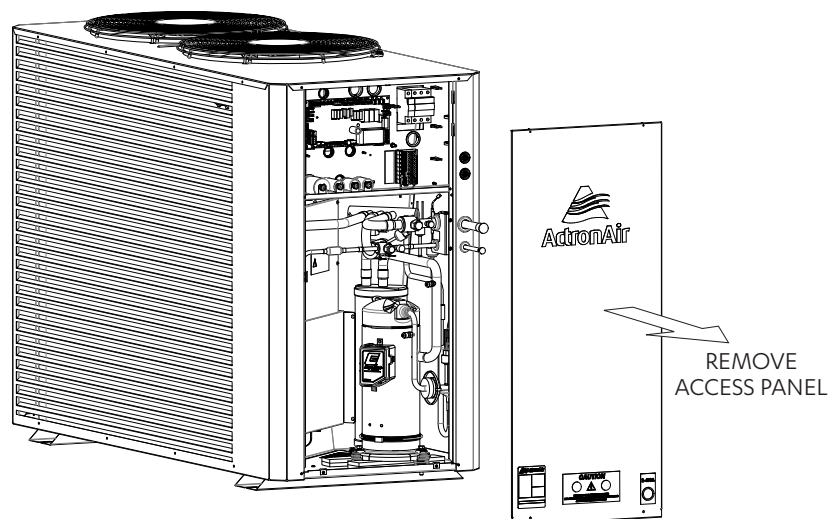
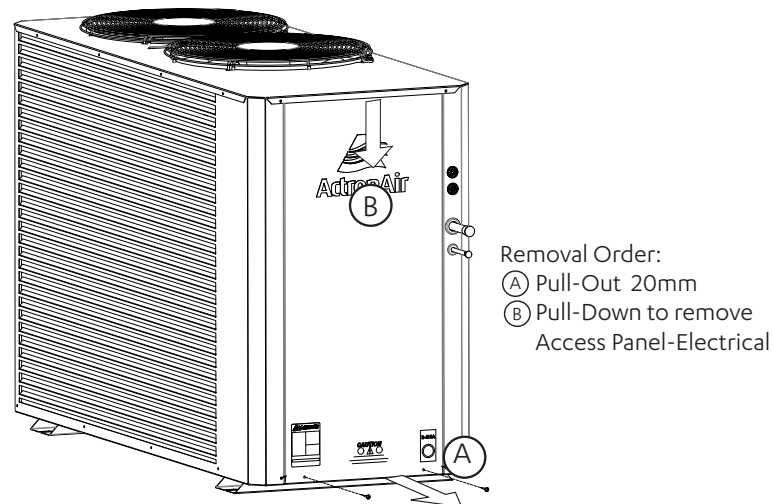

3. Remove the Shipping Blocks before installing Interconnection Field Pipes.

Loosen the set bolts that hold the compressors down onto the unit (3 pcs)

Remove Shipping blocks as shown below.

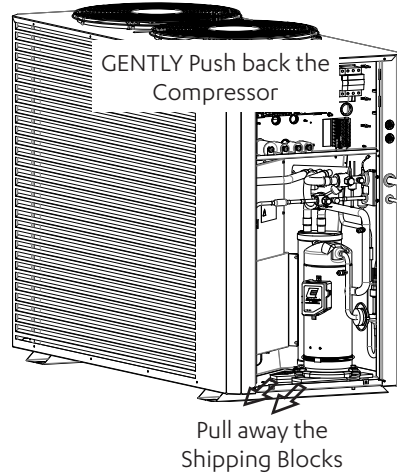
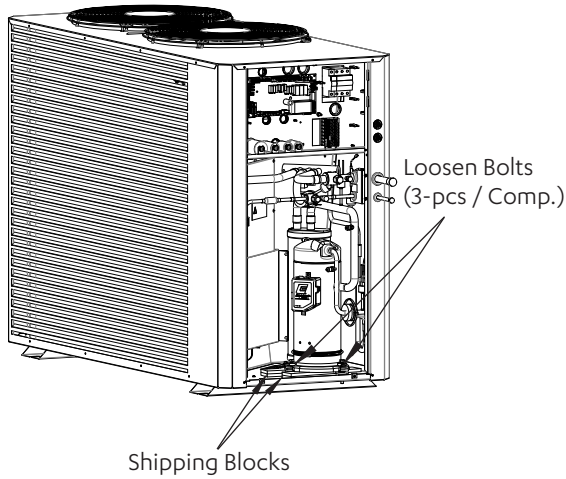

Tighten back the set bolts that hold the compressors down onto the unit (3 pcs)

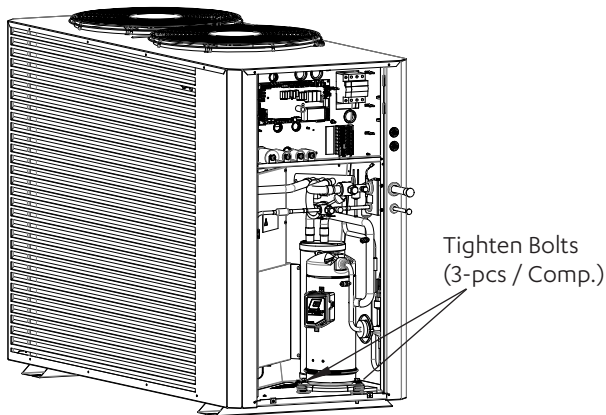

4. Install Interconnecting Field Pipes

- Braze refrigeration piping. Refer to Section on Field Pipe Connection for details of field pipe sizes and piping installation procedure.

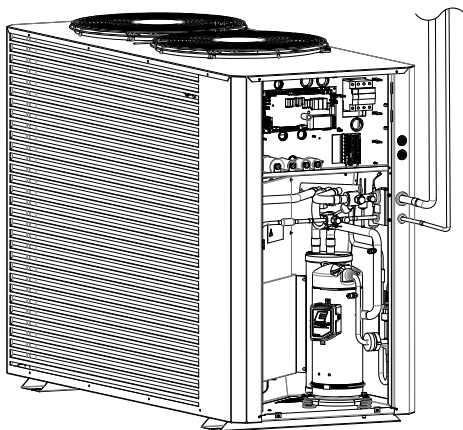

WARNING

Live electrical within enclosure. Isolate electrical supply before removing panels. Authorised technicians access only.

Field Pipe Connection

Piping and Brazing



CAUTION

This outdoor unit described in this guide is designed to match only with an ActronAir indoor unit as specified in the Technical Selection Catalogue.

- The unit is supplied with factory charged refrigerant as stated in the Rating Label. The use of other material as a refrigerant may cause explosion and/or personal injury.
- Be aware of all the relevant regulations concerning the handling of refrigerant.
- The system of this unit operates with Polyolester (POE-46)* oil.
- The maximum time any system can be opened to atmosphere is 15 minutes.
- It is important to work with absolute cleanliness.
- Secure Hot Work Permit as required.
- Brazing must be done with the use of Nitrogen to avoid carbon deposits into the pipes.
- The system must be evacuated thoroughly to 500 microns (see evacuation procedure).
- Never allow refrigerant to vent into the atmosphere. It is an offence to release refrigerant in Australia.
- Always reclaim refrigerant using equipment and container dedicated for the refrigerant used in the system.
- Only qualified technicians are allowed to perform any work described in this guide and all work must be carried out in accordance with Australia and New Zealand refrigerant handling code of practice.

*CRQ Single Phase models use Polyvinylether (PVE) oil.

Maximum allowable total equivalent field pipe length is 60 metres, see diagram on the next page. This includes all the equivalent pipe fitting losses and vertical height difference. Vertical height difference must not exceed 20 metres. Table below shows the equivalent straight pipe length of elbow fittings.

TABLE : EQUIVALENT STRAIGHT PIPE LENGTH OF ELBOW FITTINGS (METRES)				
Pipe size Nominal Diameter	90° Long Radius Elbow	90° Short Radius Elbow	45° Long Radius Elbow	45° Short Radius Elbow
9.52 (3/8")	0.24	0.36	0.09	0.14
12.7 (1/2")	0.27	0.41	0.12	0.19
15.88 (5/8")	0.30	0.45	0.15	0.23
19.05 (3/4")	0.40	0.60	0.18	0.27
22.22 (7/8")	0.46	0.69	0.21	0.32
25.4 (1")	0.52	0.78	0.24	0.36
28.58 (1-1/8")	0.55	0.83	0.27	0.41

Selected field pipe sizes must match the recommended sizes in Tables on Refrigeration Piping in the Specification for Refrigeration Section. If the installation requires different field pipe diameter due to different application condition other than recommended, contact ActronAir for advice.

Most of unit pipe connections are factory swaged to easily fit to the recommended field pipe diameter.

When it is required to install other refrigeration devices, such as refrigerant drier, solenoid valve and the like, include the equivalent straight pipe length of the device in the calculation of total equivalent field pipe length and mechanical connections shall be accessible for maintenance purposes.

Both pipes are required to be insulated.

Improper insulation can result in condensation forming on the pipework's surface, potentially leading to dripping condensation.

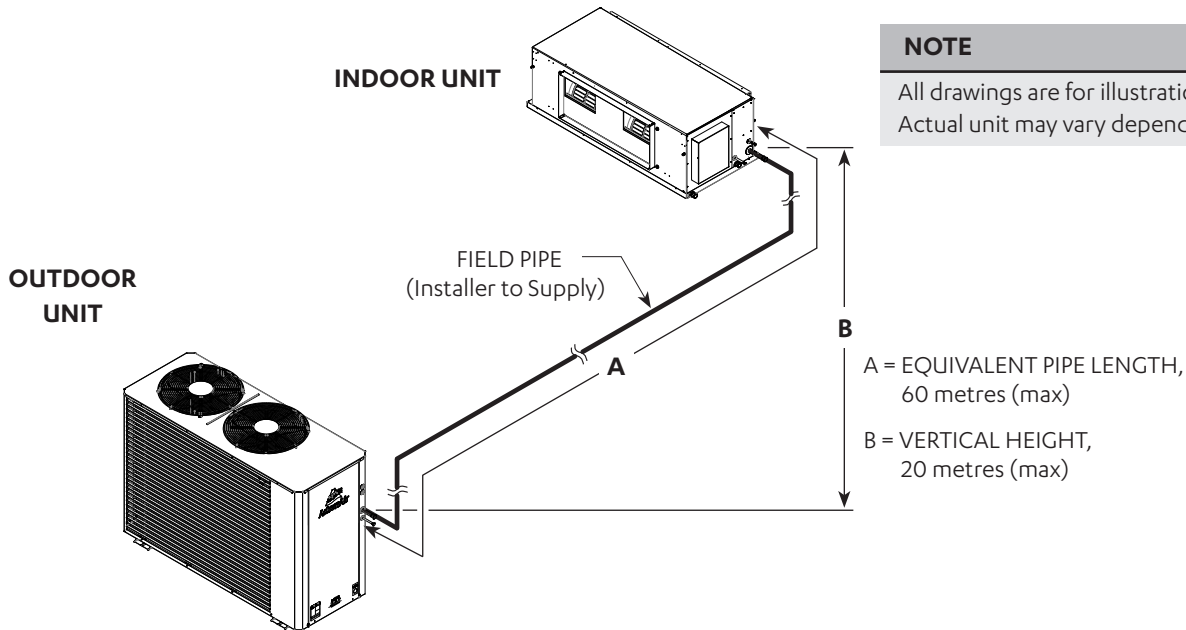

NOTE

All drawings are for illustration purposes only. Actual unit may vary depending on the model.

A = EQUIVALENT PIPE LENGTH, 60 metres (max)
 B = VERTICAL HEIGHT, 20 metres (max)

Example of Total Equivalent Field Pipe Length Calculations

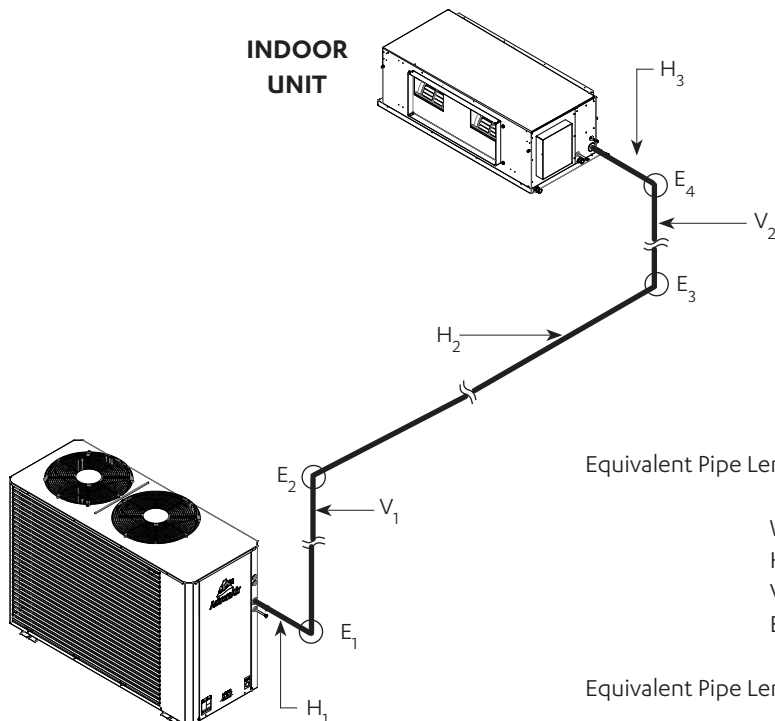

CAUTION

Above illustration shown as calculation examples only. It is the responsibility of the Installer to design an efficient refrigeration piping lay out for optimum unit performance.

Equivalent Pipe Length = Total Horizontal Length + Total Vertical Length + Total Losses from Elbows

Where:
 H = Horizontal Length
 V = Vertical Length
 E = Elbow Losses

$$\text{Equivalent Pipe Length} = (H_1 + H_2 + H_3) + (V_1 + V_2) + (E_1 + E_2 + E_3 + E_4)$$

CAUTION

Brazed joints should only be made while purging Nitrogen through the system. Failure to do so will cause carbon deposit to be left on the internal pipe surface, that in turn can cause system failure and void warranty.

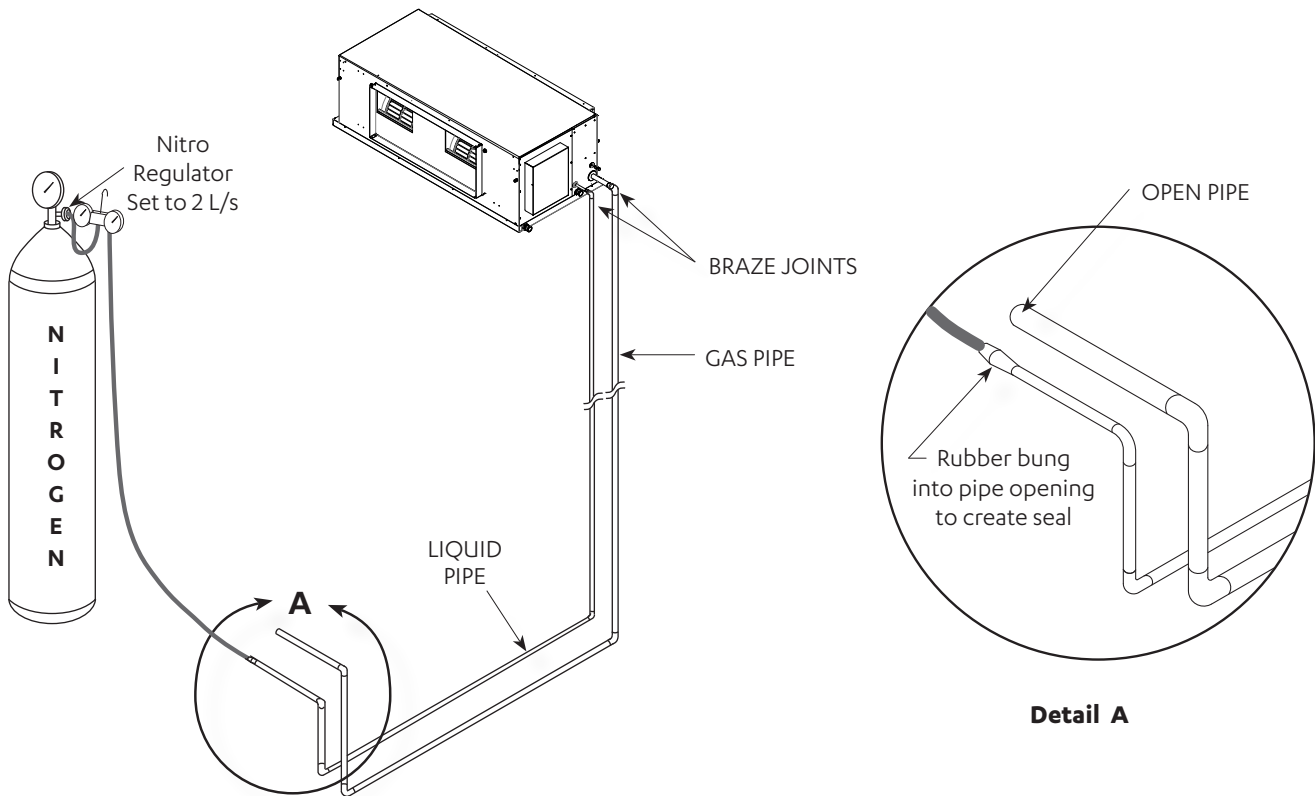

Installing interconnecting pipe work to indoor, nitrogen bleed procedure (First fit or rough in stage only)

1. Run interconnecting pipe work from condenser location to evaporator.
2. Release pressure in evaporator and remove caps.
3. Fit copper tube into tail, set nitro bottle and regulator up at condenser end of pipe work.
4. Fit nitrogen line into liquid line with rubber bung to seal the connection. The seal will prevent air being sucked into pipe work.
5. Leave suction line open, set nitro regulator for nitrogen to flow through pipe work at 2 l/s flow rate @20kPa.
6. Braze required joints as quick as possible. **See Diagram Above.**

Installing interconnecting pipe work to outdoor, nitrogen bleed procedure (First fit or rough in stage only)

1. Starting with circuit 1 system, remove piping caps from the condenser and fit pipe work into tails.
2. Fit nitro hose onto suction ball valve and fit open hose onto liquid line post valve.
3. Set nitrogen regulator to 2 l/s flow rate through pipe work and evaporator.
4. Braze remaining joints as quick as possible.
5. Allow the brazed joints to cool and conduct leak test in the connections.

Pressure Testing

Pressure test the system between 2500kPa and the system's maximum kPa as determined in **AS/NZS 5149.2:2016, Clause 5.2.2.1 Maximum Allowable Pressure**. Ensure pressure is held for no less than 1 hour.

NOTES

Importance of Evacuation:

- Any non-condensable product left in the system can cause the pressure in the high side of the system to increase and in turn, the compression temperature to rise.
- Moisture will result in adverse reaction in the refrigerant circuit.
- To prevent chemical reactions in the system, any moisture must be removed at all costs.
- Oxygen (air) reacts with the compressor oil and can lead to faults such as compressor failure.

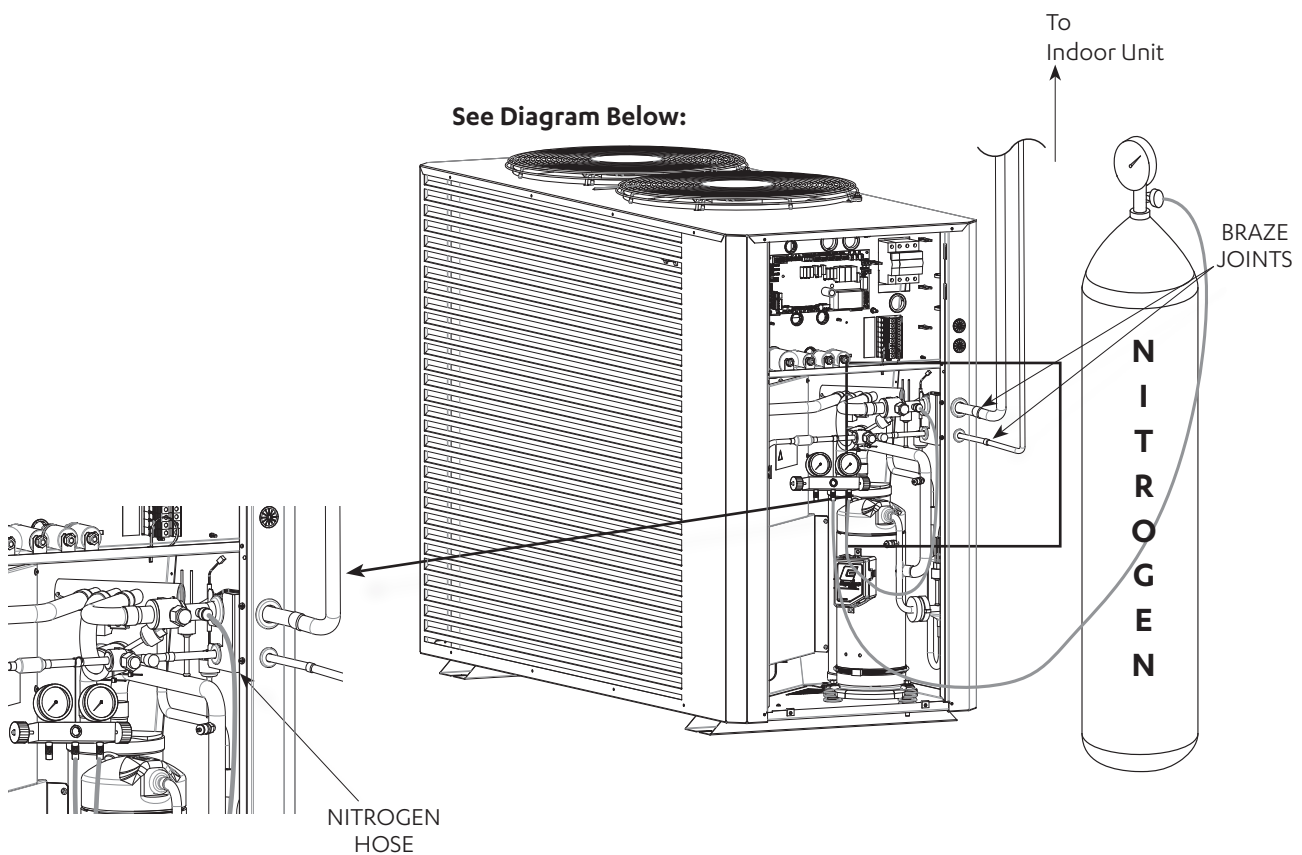

Evacuation Procedure (Triple Evacuation)

1. Fit service gauges to the ball valves (liquid line service valve and suction line service valve).
2. Evacuate the system to 1000 microns.
3. Check vacuum with vacu stat. Break the vacuum with dry Nitrogen to 100kPa.
4. Release Nitrogen pressure. Evacuate to 500 microns.
5. Check vacuum with vacu stat. Break the vacuum with dry Nitrogen to 100kPa.
6. Release Nitrogen pressure. Evacuate to 500 microns.
7. Check vacuum with vacu stat. Let the unit stand for 1 hour and with the vacuum not rising above 500 microns.
8. Open valve.

CLOSE
(As Shipped Position)

OPEN
(Operating Position)

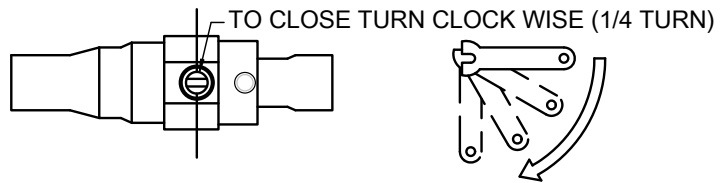
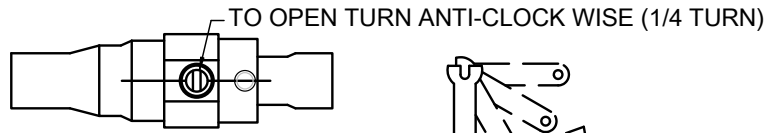

Electrical Installation

All electrical work must be carried out by a qualified technician. Make sure all wiring is in accordance with local wiring rules. Wiring connections should be made in accordance with the wiring diagram provided.

DANGER

Live Electrical Supply !

- During installation of your air conditioning unit, it may be necessary to work in close proximity to live electricity. Only qualified technicians are allowed to perform these tasks.
- Follow all electrical safety precautions when exposed to live electrical components.
- Always make sure that all power supply, including remote controls, are disconnected before performing maintenance. Observe proper LOCK-OUT / TAG-OUT (LOTO) procedures to ensure that power cannot be inadvertently energised. Failure to disconnect power before maintenance procedure can result in serious injury or death.
- All electrical wiring must be in accordance with the relevant electrical authority rules and regulations.

CAUTION

STATIC SENSITIVE ELECTRONIC DEVICES !

- DO NOT handle electronic devices unless you are wearing an Anti-Static Wrist Strap that is connected to a EARTH. Failure to protect the electronic devices from static electricity may cause unrepairable damage.
- Static damaged electronic devices are NOT COVERED for replacement under warranty.

Wiring Diagram

The wiring diagrams specific for your air conditioning system are located on the inside of the electrical access panel.

Always refer all wiring installation, servicing and troubleshooting of this equipment to this diagram to ensure correct electrical connections are satisfied.

Supply and Power Requirements Procedure

It is the installer's responsibility to provide power supply wiring to the sub-mains isolator. Wiring should conform to the current electrical authority regulations and all wiring connections to be as per electrical diagram provided with the unit.

- Confirm that the power supply available is compatible with the unit nameplate ratings. The supply power must be within +10% to -6% of the rated voltage as per AS60038.
- Protect electrical service from over current and short circuit conditions in accordance with the latest edition of the AS/ NZS 3000 "Australian / New Zealand Wiring Rules". Protection devices are to be sized accordingly as per to the electrical specifications of the unit.
- Complete the outdoor unit power supply wiring into the sub-mains isolator.
- Secure the power cords and control cables that enters in/exits out the unit. Use the cable ties provided in the electrical panels.
- Provide proper unit earthing in accordance with local and national wiring rules.
- Installer to connect an appropriate load break (AC3) isolator in sub mains wiring.

Compressor Voltage Balance Requirement

Check the voltage at the mains supply terminals to determine if it is balanced. Voltage imbalance on three phase systems can cause motor overheating and premature failure. The maximum allowable imbalance is + 2.0% should voltage imbalance exceed this value, check unit wiring connections to locate and rectify faults or contact local supply authority.

Crankcase Heater

Crankcase Heater is to be disconnected for pipe lengths 8m or less.

Electrical Connection

NOTES

- To minimise noise interference, Data and Power cable clearance should be maintained as much as possible.
- All drawings are for illustration purposes only. Actual unit may vary depending on the model.

DETAILED WIRING DIAGRAM IS PROVIDED WITH THE UNIT.

Outdoor Unit: Located at the back of electrical/compressor access panel.
 Indoor Unit: Located at the back of electrical box cover.

Split Unit

- ① MAINS WIRING (230/400VAC)
 (Single Phase + Neutral + Earth) 50Hz
 (Three Phase + Neutral + Earth) 50Hz
- ② INTER-CONNECTING POWER CABLE (230VAC)
 (Single Phase + Neutral + Earth) 50Hz
- ③ DATA CABLE TO WALL CONTROLLER
 (Cat5e UTP (AWG 24) Data Cable)
- - - - ④ EXTRA LOW VOLTAGE DATA CONTROL WIRING
 (2 Core Shielded Twisted Pair 7/0.30 (0.5mm²) Data Cable)

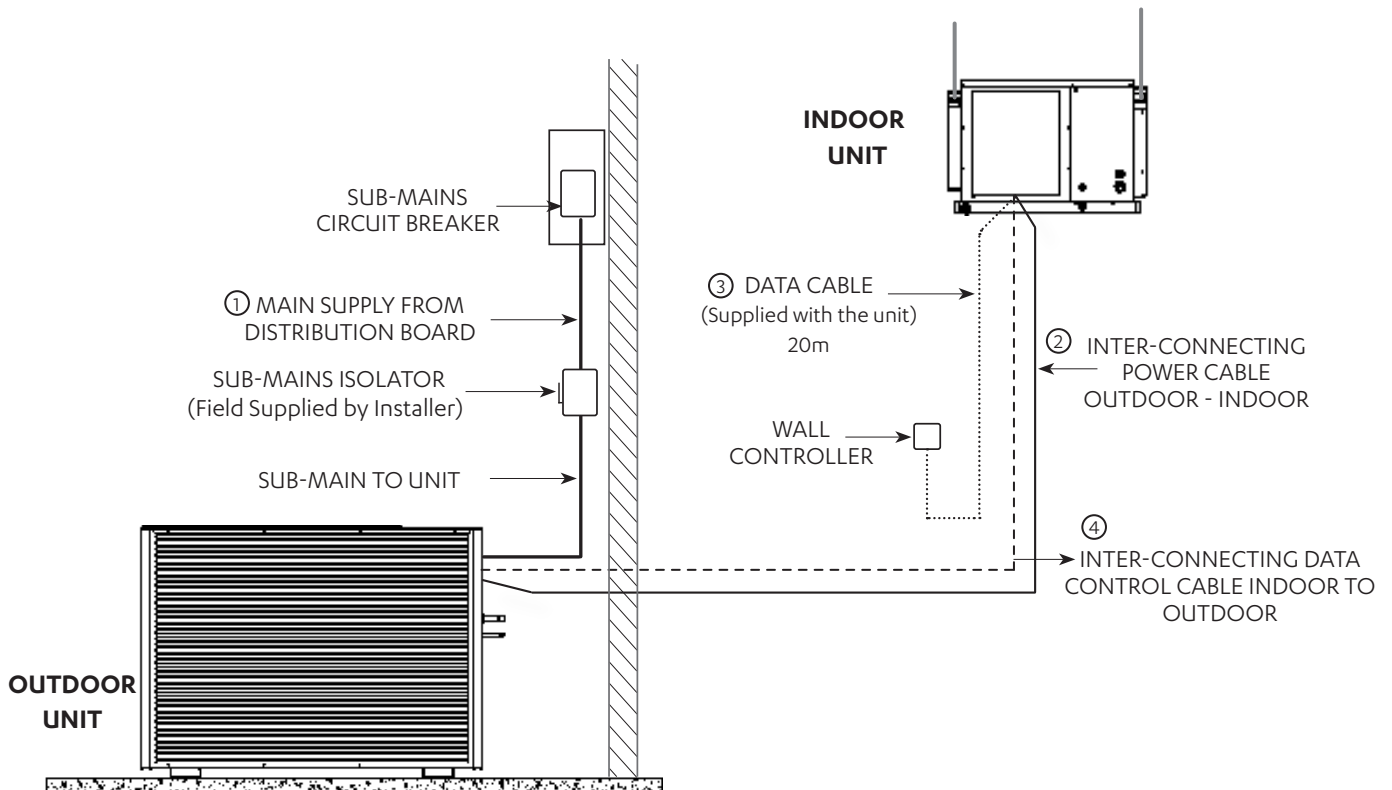

Wall Controller Options

Wall Controller Options

A maximum of three (3) wall controllers in the below combinations is allowed per unit. See below table.

Options	Wall Controllers		
	C1	C2	C3
1st Option	NEO		
2nd Option	NEO	NEO	
3rd Option	NEO	NEO	LR7-1 / LC7-2
4th Option	NEO	LR7-1 / LC7-2	
5th Option	NEO	LR7-1 / LC7-2	LR7-1 / LC7-2
6th Option	LR7-1 / LC7-2		
7th Option	LR7-1 / LC7-2	LR7-1 / LC7-2	
8th Option	LR7-1 / LC7-2	LR7-1 / LC7-2	LR7-1 / LC7-2

NOTES

- NEO - Available in White (NTW-1000) and Black (NTB-1000).
- LC7-2, LR7-1 and LM-RS-2 - Available in White and Grey.
- In the instance of a combination of NEO and LR7-1 / LC7-2 being connected together, the NEO will always need to be addressed as C1.

Wiring Configuration : Recommended

NOTES

- Diagram shown below is a general representation only. Refer to individual unit wiring diagram for complete wiring connection details.
- Long runs beside Mains cables or TV antenna cables should be avoided.
- Wiring configuration for LR7-1 and LC7-2 wall controller is the same.
- Daisy connection is not allowed for the NEO wall controller.
- Two Ferrite Clips*, if supplied, are to be placed 200mm and 400mm from the NEO controller.

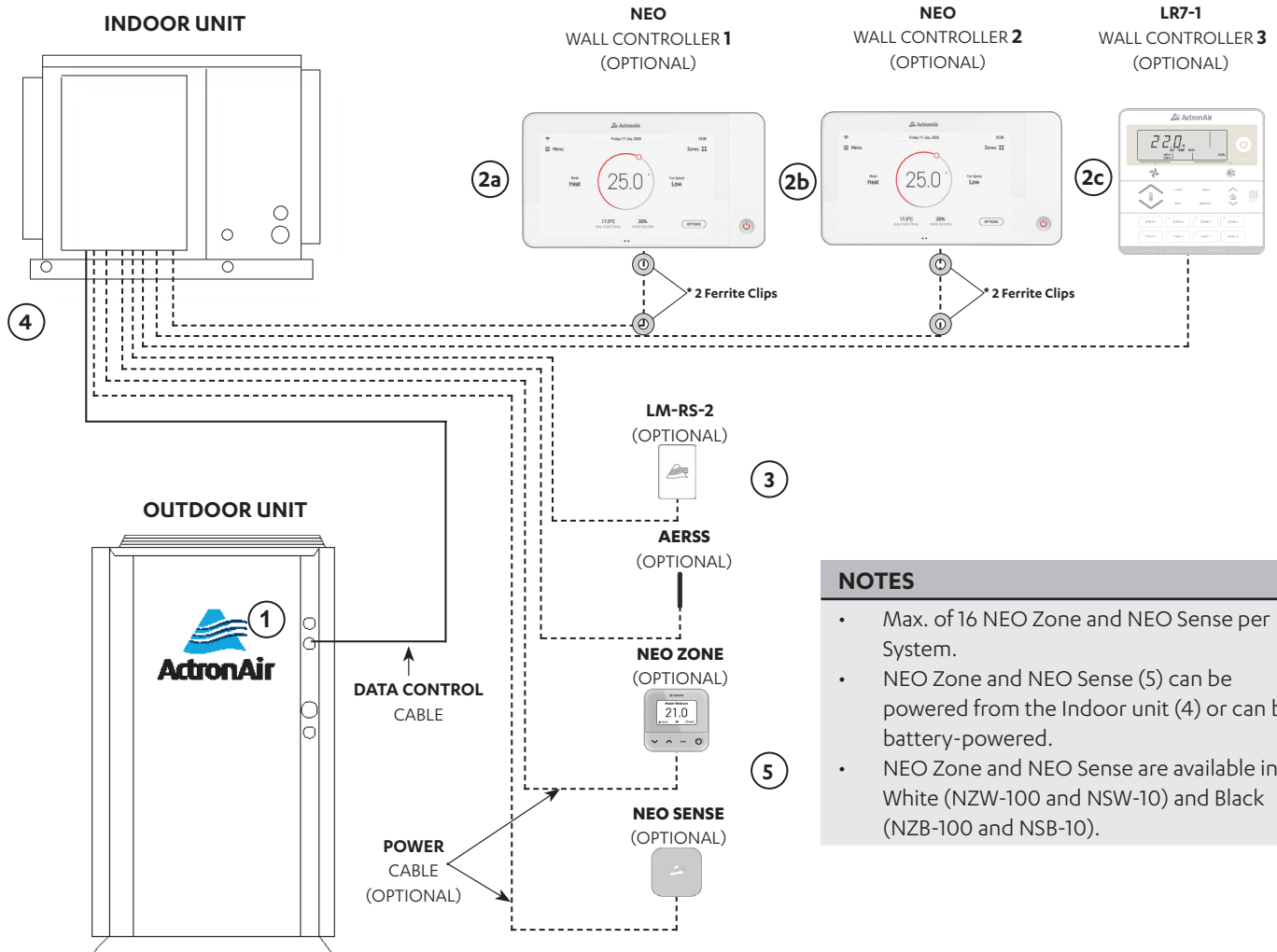

NOTES

- Max. of 16 NEO Zone and NEO Sense per System.
- NEO Zone and NEO Sense (5) can be powered from the Indoor unit (4) or can be battery-powered.
- NEO Zone and NEO Sense are available in White (NZW-100 and NSW-10) and Black (NZB-100 and NSB-10).

Item	Description	Maximum Cable Length
1 to 4	Outdoor PCB to Indoor PCB	100 m
4 to 2a, 4 to 2b	Indoor PCB to Wall Controller	90 m
4 to 2c	Indoor PCB to Wall Controller 3	100 m
4 to 3	Indoor PCB to Remote Sensor	100 m
4 to 5	Indoor PCB to ZC and ZS	100 m

Description	Cable Type
Indoor to Wall Controller	Cat5e UTP (AWG 24) Data Cable
Indoor to Remote Sensor	Cat5e UTP (AWG 24) Data Cable
Indoor to Outdoor Data Cable	2 Core (1 Pair) Twisted Pair, 7/0.30 (0.5mm ²) Shielded Data Cable

Wiring Configuration : Alternate

NOTES

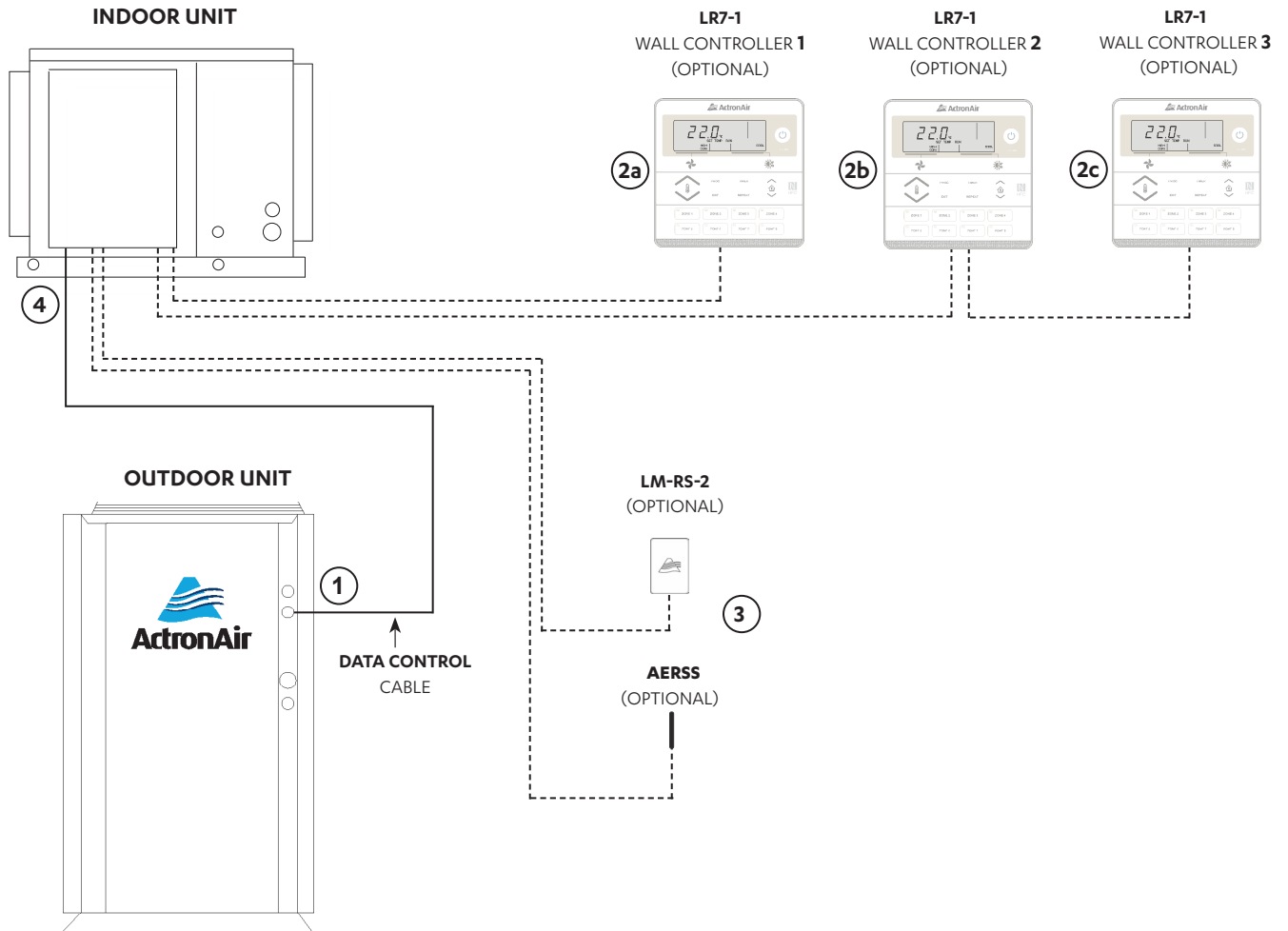

Item	Description	Maximum Cable Length
1 to 4	Outdoor PCB to Indoor PCB	100m
4 to 2a	Indoor PCB to Wall Controller 1	100m
4 to 2c	Indoor PCB to Wall Controller 3 (last controller)	75m total (Daisy Chain)**
4 to 3	Indoor PCB to Remote Sensor	100m

** Maximum Daisy Chain connection is up to 2 wall Controllers.

Description	Cable Type
Indoor to Wall Controller	Cat5e UTP (AWG 24) Data Cable
Indoor to Remote Sensor	Cat5e UTP (AWG 24) Data Cable
Indoor to Outdoor Data Cable	2 Core (1 Pair) Twisted Pair, 7/0.30 (0.5mm ²) Shielded Data Cable

Wiring Connections

LR7-1 and LC7-2 Wall Control Wiring Connections

WALL CONTROL WIRING

POWER: - BROWN / ORANGE
 485 A: - BLUE
 485 B: - BLUE-WHITE
 GND: - BROWN-WHITE / ORANGE-WHITE
 NOT USED: - GREEN / GREEN-WHITE

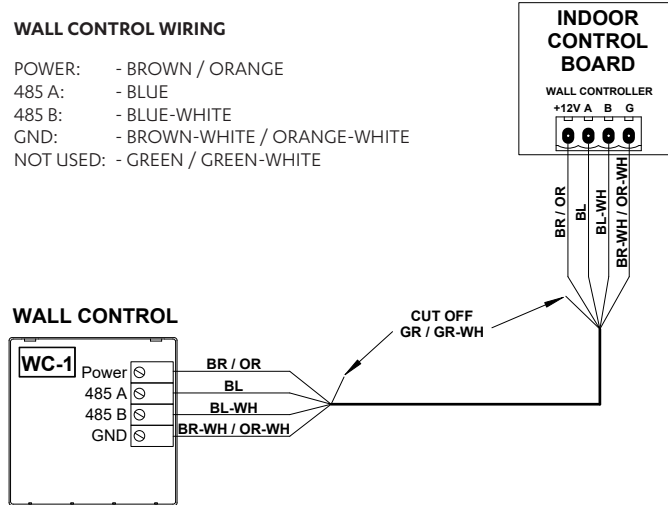

NEO Wall Control Wiring Connections

NOTES

Two FERRITE CLIPS, if supplied, should be installed 200 mm away and FERRITE 2 should be 400 mm away from the Wall Control.

NEO Hard Wiring

WALL CONTROL WIRING

POWER: - BROWN / ORANGE
 485 A: - BLUE
 485 B: - BLUE-WHITE
 GND: - BROWN-WHITE / ORANGE-WHITE
 NOT USED: - GREEN / GREEN-WHITE

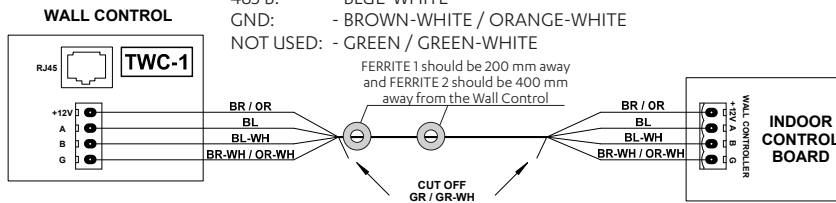

NEO RJ45 Wiring

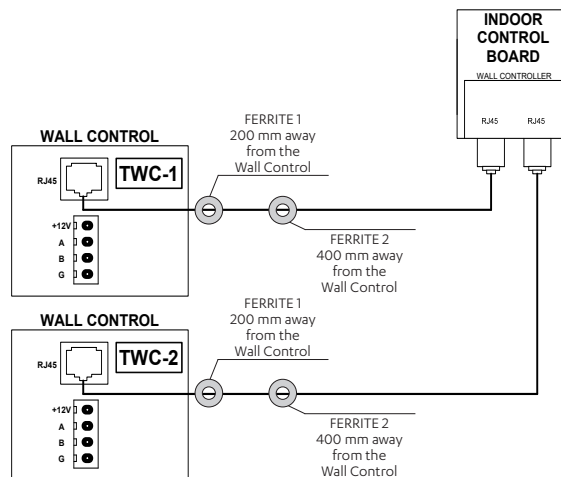

LM-RS-2 Optional Sensor Wiring Connections

REMOTE SENSOR WIRING

- PAIR 1: - BLUE / BLUE-WHITE
- PAIR 2: - ORANGE / ORANGE-WHITE
- PAIR 3: - GREEN / GREEN-WHITE
- PAIR 4: - BROWN / BROWN-WHITE

NOTE:

- PAIR 1 AND 2 USED FOR ILLUSTRATION PURPOSES ONLY.
- CUT OFF AND TERMINATE ANY UNUSED PAIRS TO ENSURE NO WIRING IS LEFT EXPOSED.

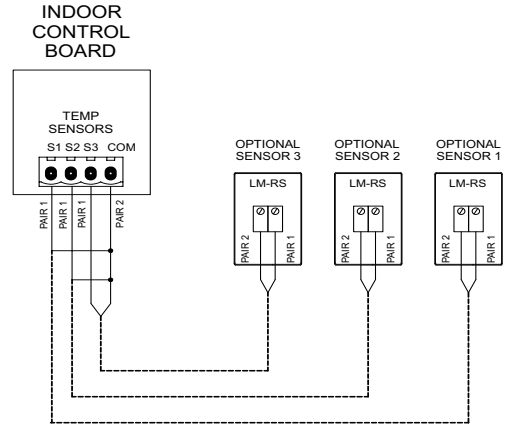

AERSS Optional Duct Sensor Wiring Connections

REMOTE SENSOR WIRING

- PAIR 1: - BLUE / BLUE-WHITE
- PAIR 2: - ORANGE / ORANGE-WHITE
- PAIR 3: - GREEN / GREEN-WHITE
- PAIR 4: - BROWN / BROWN-WHITE

NOTE:

- PAIR 1 AND 2 USED FOR ILLUSTRATION PURPOSES ONLY.
- CUT OFF AND TERMINATE ANY UNUSED PAIRS TO ENSURE NO WIRING IS LEFT EXPOSED.

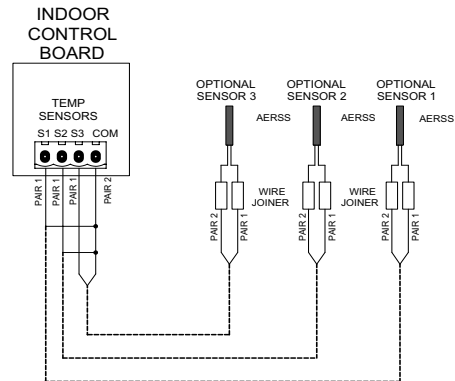

Data Cable Shielding Instructions

2 Core Twisted (ActronAir Part Number: AEDC2)

NOTES

- Maintain the twist of the core wires up to the Green Terminal Plug.
- Maximum strip length of outer insulation to the Green Terminal Plug is 50mm.
- Make sure the cable colors used for the Data Terminal in Outdoor Unit match the Data Terminal in Indoor unit.

Outdoor Unit Data Terminal (Green Plug)

“Terminal A” - White Wire

“Terminal B” - Black Wire

“Terminal G” - Shield Wire

Indoor Unit Data Terminal (Green Plug)

“Terminal A (+)” - White Wire

“Terminal B (-)” - Black Wire

“Terminal G” - Shield Wire

Insert data cable through the lower snap bushing and first cable tie on the right hand side of the electrical panel.

Connect core wires and shield wire into the Outdoor Board green terminal plug marked “INDOOR A, B and G”.

(Refer to unit wiring diagram for complete wiring connection details).

NOTE

All drawings are for illustration purposes only. Actual unit may vary depending on the model.

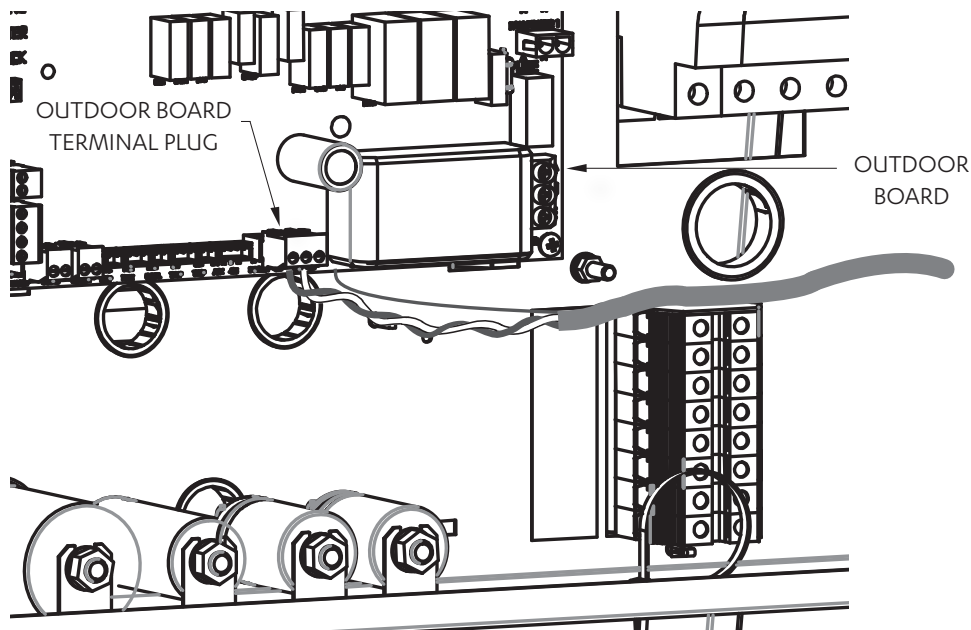

Fig. 3

Circuit Breaker Size and Cable Size Requirement

Model	Circuit Breaker Size	Cable Size * (mm ²)	
	Amps	MAIN	O.D. to I.D.
CRV140S/EVV140S	25.0	4.0	1.0
CRV160S/EVV160S	32.0	6.0	1.0
CRV180S/EVV180S	32.0	6.0	1.0
CRV160T/EVV160S	20.0	2.5	1.0
CRV180T/EVV180S	20.0	2.5	1.0
CRV210T/EVV210S	25.0	4.0	1.5
CRV240T/EVV240S	25.0	4.0	1.5

* Suggested Minimum Cable Size should be used as a guide only, refer to AS/NZS 3000 "Australian / New Zealand Wiring Rules" for more details.

Demand Response Management

These products are compliant to AS/NZS 4577.3.1:2012

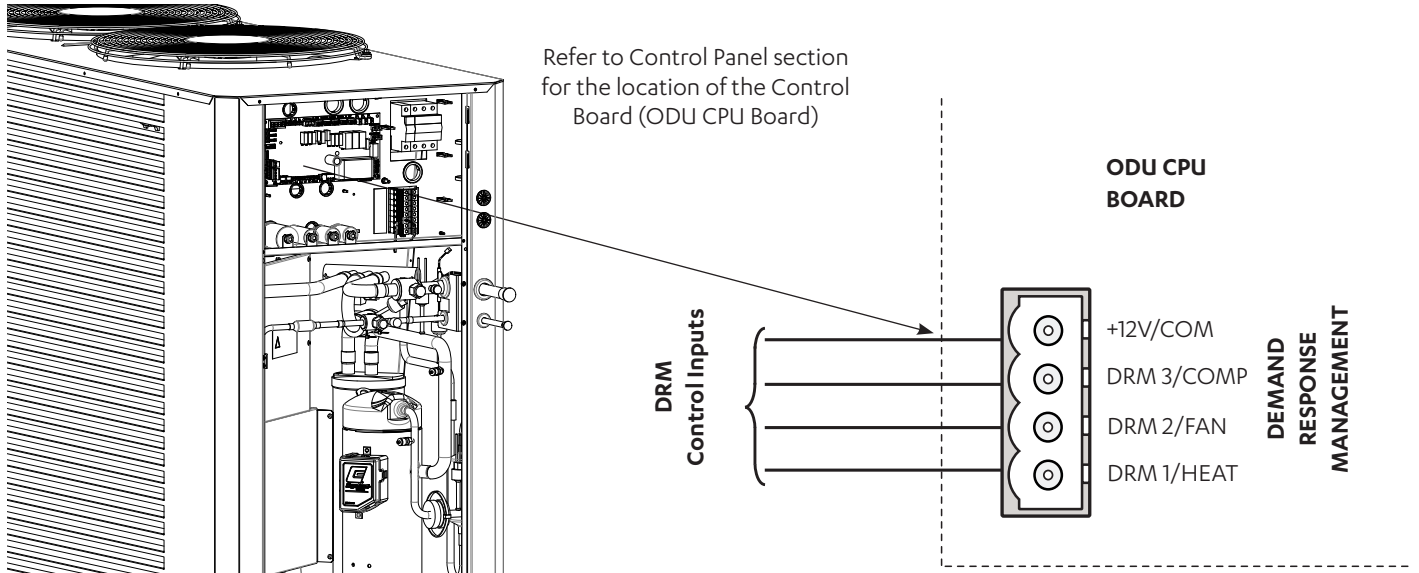

1. Route DRM input cables into the Unit (as per previous wiring installation procedure).
2. Connect cables into terminals (as per wiring diagram provided with the unit).

Demand Management Mode	Description Of Mode Allowable Range (%)	Operating Mode
DRM1	Compressor Off Mode	Compressor <u>ONLY</u> will cycle Off and remain Off for the entire Demand Response event. All other functions will operate as normal (i.e. Indoor Fan)
DRM2	Maximum 50% power use mode with 0 to <50% allowable power use range	Compressor 0 to <50% operation range for the total Demand Response event.
DRM3	Maximum 75% power use mode with 0 to <75% allowable power use range	Compressor 0 to <75% operation range for the total Demand Response event.

DEMAND RESPONSE ENABLING DEVICE CIRCUIT DIAGRAM

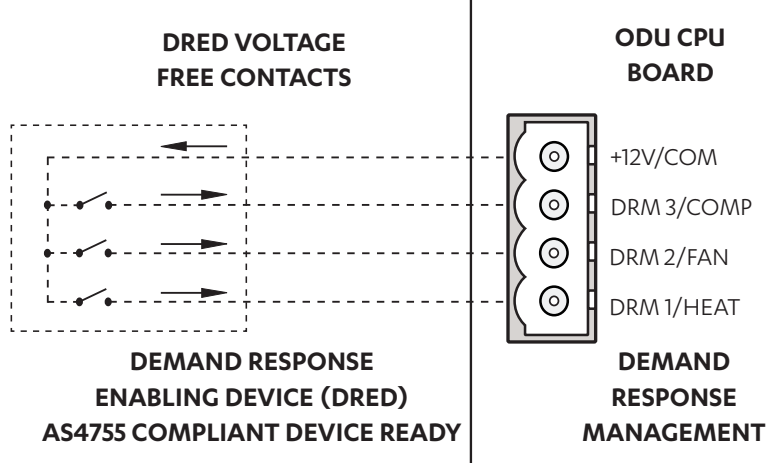

NOTES

- Demand Response Management is not applicable when using third party control.
- Contact your electricity authority to install and activate DRED.
- All drawings are for illustration purposes only. Actual unit may vary depending on the model.

Configuring and Commissioning Setup

Menu and Navigation

diS (Display)	Display system's status and settings	
SEr (Service)	Service use only	
SEt (Settings)	cnFg	04.00 = Family*
		04.24 = Capacity*
	CtrS	Ct. 0 = Third Party
		Ct. 1 = Wall Control (default)
		Ct. 2 = Basic BMS
		Ct. 3 = Wall Control + Basic BMS
		Ct. 4 = Advanced BMS
	iduS	FP1 = IDU Fan Low PWM setting
		FP2 = IDU Fan Med PWM setting
		FP3 = IDU Fan High PWM setting
		Fr1 = IDU Fan Low RPM setting
		Fr2 = IDU Fan Med RPM setting
		Fr3 = IDU Fan High RPM setting
		FPd = IDU Fan Defrost PWM setting
		FPc = IDU Reduced Airflow PWM setting
		FiL = IDU Fan Filter Hours setting
		Econ = IDU Econ 0-10V Output setting
		FnSE = Indoor Fan Setting
	HtSt = HotStart On/Off	
	SoFt	no = Soft Start not enabled (default)
		YES = Soft Start enabled
	run	no = Indoor Fan and Compressor (default)
		YES = Compressor only
	odFs	Hi= High Start-up Speed (default)
		Lo= Low Start-up Speed

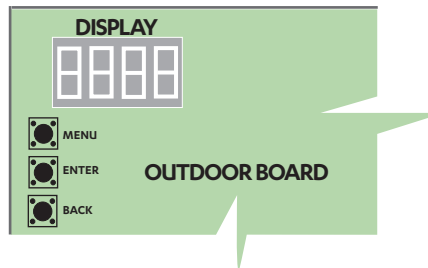

MENU

Scroll through the items at the same menu level.

Increment the value being set.

ENTER

Go into the selected menu.

Lock in selected value.

BACK

Go back to the parent menu.

Press and hold to go back to main menu

* Family and Capacity are the representative values only and may vary depend on the model purchased as seen below table. **Do not change setting.**

Model	CRV140S	CRV160S	CRV180S	CRV160T	CRV180T	CRV210T	CRV240T
Family	Capacity (kW)						
04	-	-	-	16	18	21	24
05	14	16	18	-	-	-	-

Configuring Compressor and Capacity(cnFg)

Configure the compressor type and capacity. The unit is factory configured. **Do not change this setting.**

Configuring Control Source (CtrS)

This commissioning is applicable for BMS and third party control.

Configurable settings are as follows:

Third Party Control

The unit can be controlled by non-ActronAir wall control. To do this, **CtrS** on the Outdoor Board has to be set to **Ct. 0**. For connection details, see the wiring diagram supplied with the outdoor unit.

Wall Control

ActronAir offers NEO, LR7-1 and LC7-2, wall controls that can control the available features and maximise the function and operation of the air conditioner. To do this, CtrS on the Outdoor Board must be set to **Ct. 1**.

Basic BMS

The unit can be connected to a network through a BMS card (ICUNO-MOD). This allows the unit to be operated in the same way the as the NEO, LR7-1 and LC7-2 does. To do this, **CtrS** on the Outdoor Board must be set to **Ct. 2**.

Wall Control + Basic BMS

The unit can be connected to a network (Basic BMS) and at the same time be controlled using the NEO, LR7-1 or LC7-2 controller. Priority will be given to the most recent command. To do this, **CtrS** on the Outdoor Board must be set to **Ct. 3**.

Advanced BMS

The unit can be connected for system that requires customised functions not included in the existing software or logic in the Outdoor Board but still retaining the safety logic. To do this, **CtrS** on the Outdoor Board must be set to **Ct. 4**.

Auto Fan Function

Auto fan function can only be commissioned by ActronAir wall control such as NEO, LR7-1 and LC7-2.

Third Party Control Input (Indoor and/or Outdoor Board)

This option allows Fan, Compressor and Reversing Valve to be controlled by a Third Party Control. There are two ways on how the Indoor Fan may be controlled, using 0-10V Analogue Input or Fixed Indoor Fan Speed.

NOTE

- Demand Response Management (DRM) is not available if Third Party Control Option is used.
- Ensure control source has been configured for Control Mode 0.
 1. On the Outdoor Board, set Control Source to Third Party. Using the MENU and the ENTER buttons, navigate to SEt (Settings) --> CtrS (Control Source).
 2. Use the MENU button to navigate to 0 to select Third Party Control as the control source. Press the ENTER button to save the setting.

0-10V Analogue Input for Compressor and Indoor Fan

Indoor Fan Connection (Indoor Board)

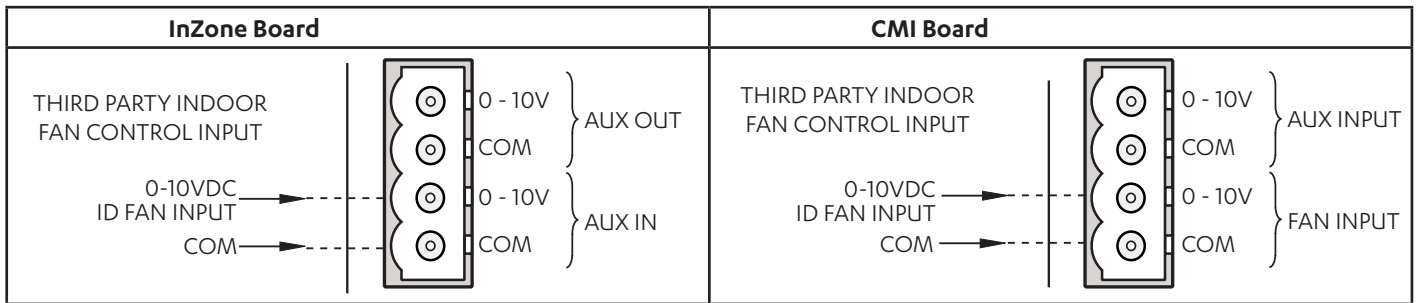

Indoor Fan Setting (Indoor Board)

InZone Board	CMI Board
No additional setting required.	On the indoor board ensure dip switch ONE and TWO are ON .
	<p>ON</p> <p>OFF</p>

Input (DC)	Output	Fan Status
0.0V to 0.99 V	0%	Off
1.0V to 1.49 V	0 or 20%	Off or On
1.5V to 9.5 V	20% to 100%	On
9.5V to 10 V	100%	On

Compressor and Reversing Valve Connection (Outdoor Board)

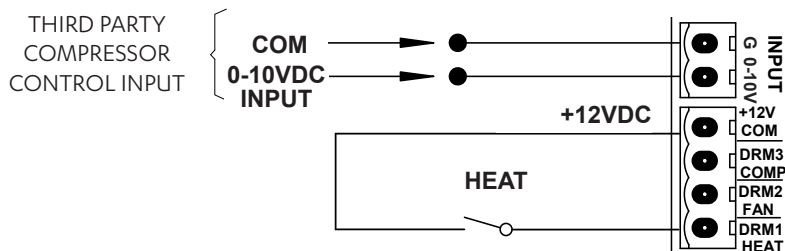

Input (DC)	Output	Compressor Status
0 - 0.99 V	0%	Off
1 - 1.49 V	0 or 20%	Off/On (hysteresis)
1.5 - 9.5 V	20% to 100%	On
9.5 - 10 V	100%	On

NOTES

- As the compressor turns ON and the Indoor fan signal is not available then indoor fan will start to run on medium PWM speed.
- Indoor fan low and high PWM limits depends upon the model. Refer to Indoor Fan Table and Fan Curve Section.
- The Voltage can be linearly interpolated using the above table to determine the desired PWM or unit output.
- Only applicable for CMI board: If the compressor turn ON, during reduced fan operation, the controller will increase the fan speed to the "low PWM fan limit" if it is running less than the low PWM Limits.

0-10V Analogue Input for Compressor with Fixed Indoor Fan Speed

This feature allows for the Indoor Fan to be controlled externally (ON/OFF only).

Indoor Fan Connection (Indoor Board) AS IS

When using fixed speed indoor fan, there would be no wiring onto the InZone nor CMI.

Indoor Fan Setting (Indoor Board)

InZone Board	CMI Board
No additional setting required.	On the indoor board ensure that only dip switch TWO is ON .

Fan, Compressor and Reversing Valve Connection (Outdoor Board)

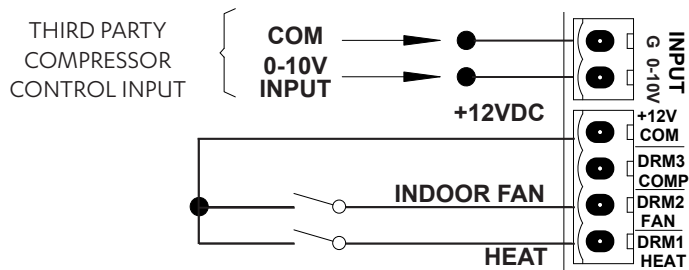

NOTES

- As the compressor turns ON and the Indoor fan signal is not available then indoor fan will start to run on medium PWM speed.
- Indoor fan operation when fan signal is available:
 - Compressor ON : Indoor fan will run on medium speed.
 - Compressor OFF :
 - » CMI: Indoor fan will run on reduce airflow operation.
 - » InZone: Indoor fan is dependent of the controller setting.

Input for Fixed Compressor with Fixed Indoor Fan Speed

This feature allows for both Compressor and Indoor Fan to be controlled externally (ON/OFF only).

Indoor Fan Setting (Indoor Board)

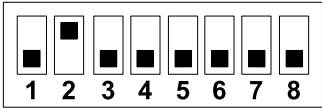
InZone Board	CMI Board
No additional setting required.	On the indoor board ensure that only dip switch TWO is ON .
	<p>ON</p>  <p>OFF</p>

Fan, Compressor and Reversing Valve Connection (Outdoor Board)

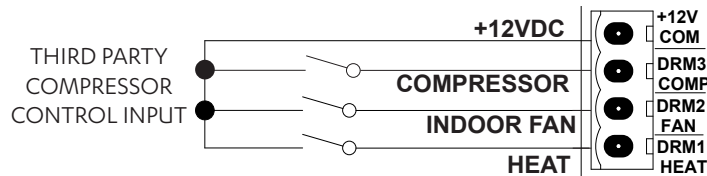

NOTES

- As the compressor turns ON and the Indoor fan signal is not available then indoor fan will start to run on medium PWM speed.
- Indoor fan operation when fan signal is available:
 - Compressor ON : Indoor fan will run on medium speed.
 - Compressor OFF :
 - » CMI: Indoor fan will run on reduce airflow operation
 - » InZone: Indoor fan is dependent of the controller setting.
- Compressor turns on with 100% speed request.
- Although the compressor will have 100% speed request, the speed may vary depending on compressor safety requirements. This will be shown on the outdoor board display.

0-10V Analogue Input for Indoor Fan with Fixed Speed Compressor

This feature allows for the compressor to be controlled externally (ON/OFF only).

Indoor Fan Connection (Indoor Board)

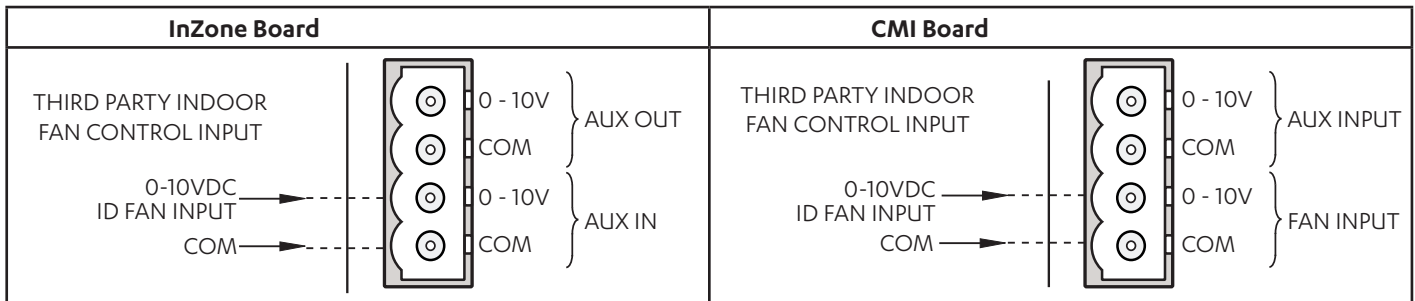

Indoor Fan Setting (Indoor Board)

InZone Board	CMI Board
No additional setting required.	On the indoor board ensure dip switch ONE and TWO are ON .
	<p>ON</p>  <p>OFF</p>

Input (DC)	Output	Fan Status
0.0 V to 0.99 V	0%	Off
1.0 V to 1.49 V	0 or 20%	Off or On
1.5 V to 9.5 V	20% to 100%	On
9.5 V to 10 V	100%	On

Fan, Compressor and Reversing Valve Connection (Outdoor Board)

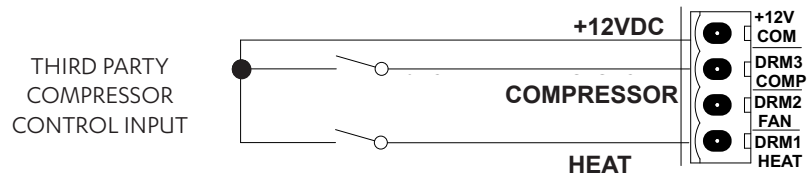

NOTES

- As the compressor turns ON and the Indoor fan signal is not available then indoor fan will start to run on medium PWM speed.
- If the compressor turn ON, during reduced fan operation, the controller will increase the fan speed to the "low PWM fan limit" if it is running less than the low PWM Limits.
- Indoor fan low and high PWM limits depends upon the model.
- The Voltage can be linearly interpolated using the above table to determine the desired PWM or unit output.
- Compressor turns on with 100% speed request.

Run and Fault Indication Output (Outdoor Board)

To activate, the unit must be wired as illustrated below. If required, a fault output connection terminal is also available to show any error/fault with the a/c system. RUN/FAULT relay outputs (230VAC/5A MAX) connection.

Run Indication

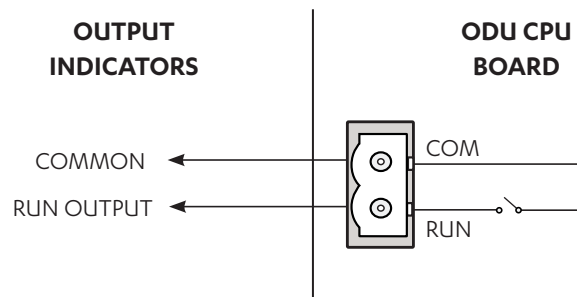

Run Output is configurable to indicate that the unit is running. There are two configurations in which this can be set:

- Either the compressor or the Indoor Fan only is running
- Only Compressor is running.

By default, this is set to turn on when either indoor fan or compressor is operating. To set up to compressor run indication only, in OD Board Menu follow below steps.

1. Using the **MENU** and the **ENTER** Buttons on the outdoor PCB, navigate to **SEt** (Settings) → **run** (Unit Operation Indicator Settings).

- If required, press **MENU** to navigate to **YES**.

Fault Indication

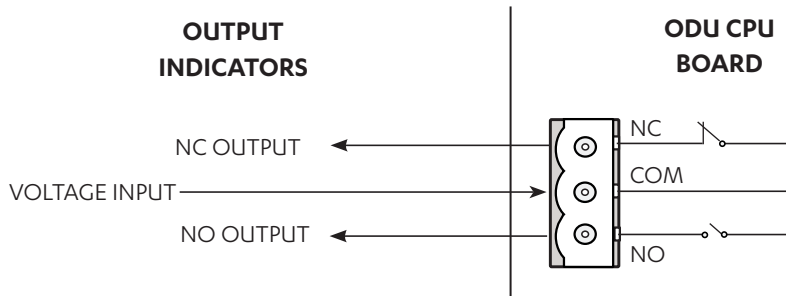

To indicate any system fault, outdoor controller will provide a signal through the Fault Indication relay. An installer can use either NC or NO output as per their requirements.

Remote On/Off

To activate, the unit must be wired as illustrated below. This will enable unit to be turned ON and OFF from the Outdoor board.

NOTES

The system must be operating in Wall Controller only (control mode 1) or BMS + Wall Controller (control mode 3) for this function to work.

- On the Outdoor Board, set Control Source to Third Party. Using the MENU and the ENTER buttons, navigate to SEt (Settings) --> CtrS (Control Source).
- Use the MENU button to navigate to "1" or "3" to select "Wall Controller only" or "BMS + Wall Controller" as the control source. Press the ENTER button to save the setting.

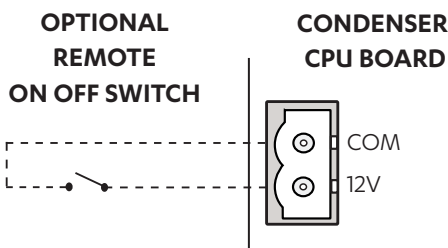

Turning the system On and Off by remote method

Turning the system On	Status 1: The system is Off and the remote switch/relay has been left in the open position. <ol style="list-style-type: none"> Close remote switch/relay. System will start in approximately in 30 seconds.
	Status 2: The system is Off and the remote switch/relay has been left in the closed position. <ol style="list-style-type: none"> Open remote switch/relay for a minimum of 5 seconds. Close remote switch/relay. System will start in approximately in 30 seconds.
Turning the system Off	Status 3: The system is On and the remote switch/relay has been left in the closed position. <ol style="list-style-type: none"> Open remote switch/relay. System will turn Off in approximately in 30 seconds.
	Status 4: The system is On and the remote switch/relay has been left in the open position. <ol style="list-style-type: none"> Close remote switch/relay for a minimum of 5 seconds. Open remote switch/relay. System will turn Off in approximately in 30 seconds.

Indoor Fan Commissioning

EVV140S / EFV140S

APPLICATION RANGE (COMPRESSOR ON) *										
AIRFLOW (l/s)	EXTERNAL STATIC PRESSURE (Pa)									
	50		100		150		200		250	
	% PWM	W	% PWM	W	% PWM	W	% PWM	W	% PWM	W
500	28	100	35	151	40	206	46	268	51	330
550	32	121	39	179	44	227	50	295	55	360
600	37	145	44	207	49	263	54	326	60	394
630	40	162	47	220	52	285	58	351	63	417
650	42	173	48	229	54	299	60	368	65	432
700	47	197	53	260	60	334	65	400	72	480
750	52	227	60	303	66	379	72	449	96	709

NOTES

* Only applicable to Third Party controllers

W = Indoor Fan Power, Watts

PWM = Pulse Width Modulation Setting, % PWM (Adjustable through the LR7-1, LC7-2, NEO or Outdoor Board).

Default Fan Speed Value at 100 Pa	
Speed	Default PWM (adjustable)
High PWM (%)	60
Medium PWM (%)	47
Low PWM (%)	35

Indoor Fan PWM Limits	
High PWM Limit	99
Low PWM Limit	28

EVV140S / EFV140S : Three Speed Application Fan Curve

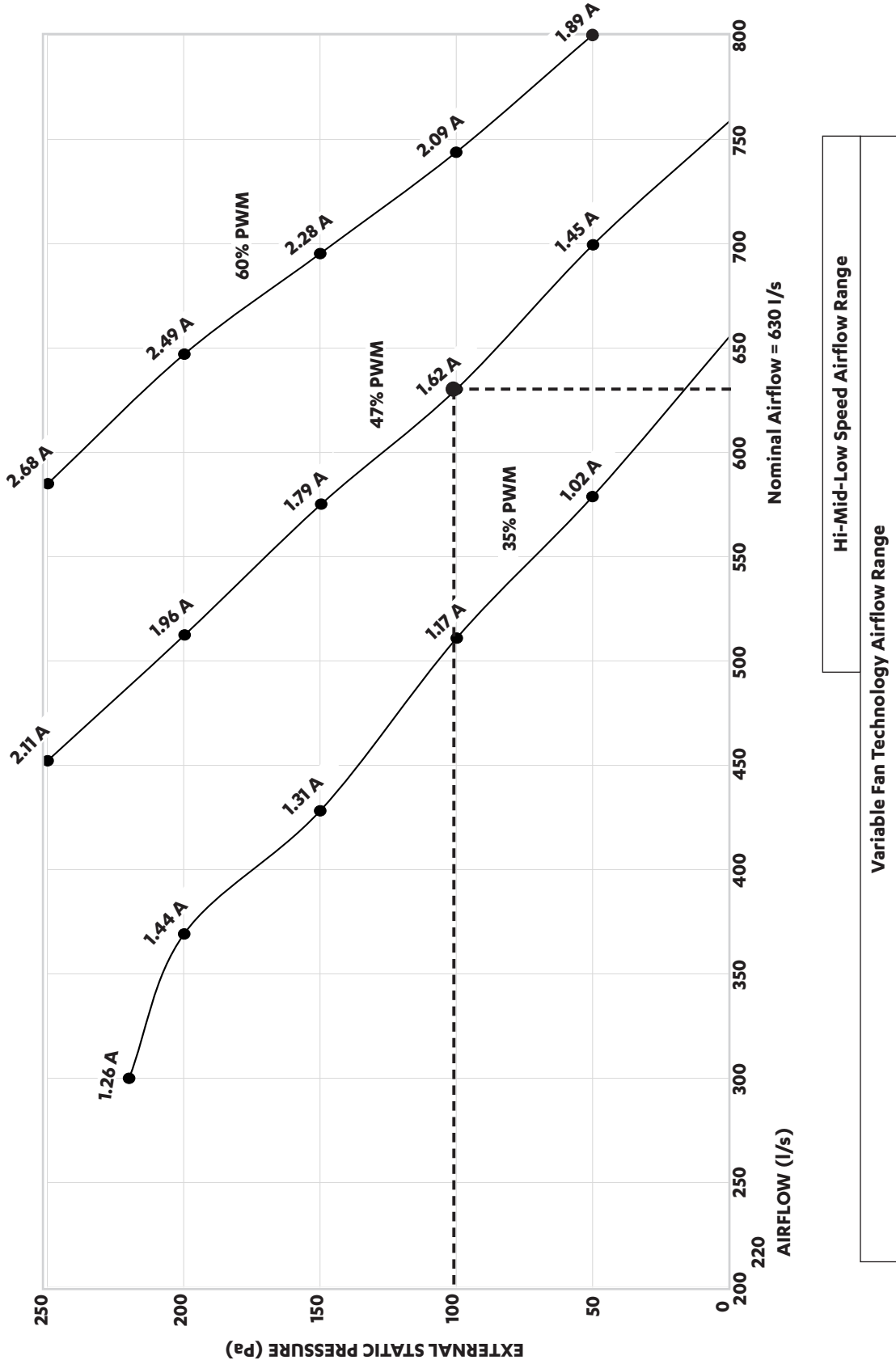

EVV140S / EFV140S : Third Party Application Fan Curve

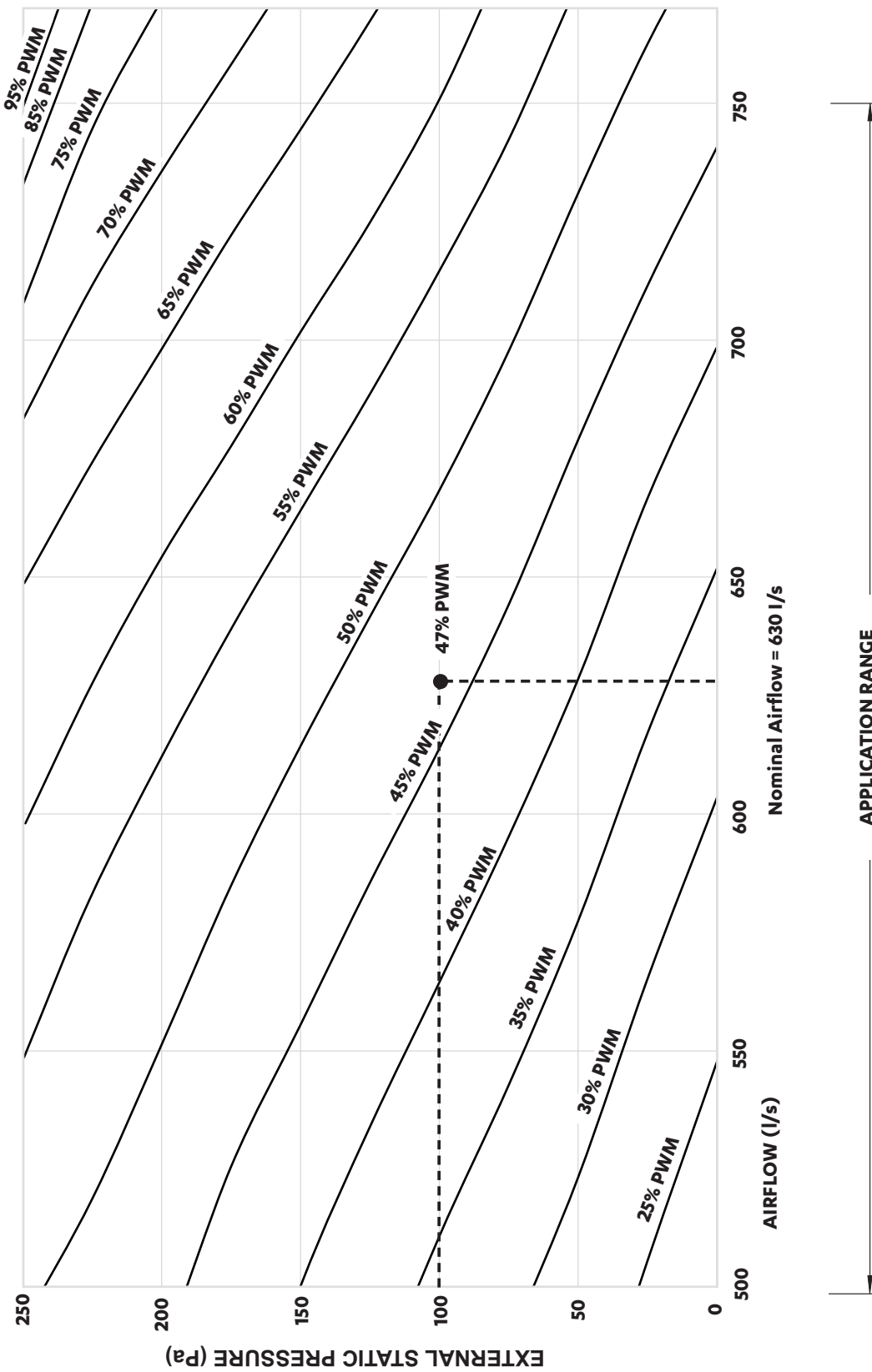

EVV160S / EFV160S

APPLICATION RANGE (COMPRESSOR ON) *										
AIRFLOW (l/s)	EXTERNAL STATIC PRESSURE (Pa)									
	50		100		150		200		250	
	% PWM	W	% PWM	W	% PWM	W	% PWM	W	% PWM	W
600	36	147	42	203	47	257	52	315	57	378
650	41	173	46	225	52	291	58	362	63	423
700	45	192	52	266	58	334	63	400	70	471
750	51	228	58	304	63	372	69	446	MOTOR / BLOWER UNIT	
800	57	262	63	340	69	419	80	505		
850	63	305	69	386	78	482				
900	69	348	77	442	91	538				

NOTES

* Only applicable to Third Party controllers

W = Indoor Fan Power, Watts

PWM = Pulse Width Modulation Setting, % PWM (Adjustable through the LR7-1, LC7-2, NEO or Outdoor Board).

Default Fan Speed Value at 100 Pa	
Speed	Default PWM (adjustable)
High PWM (%)	77
Medium PWM (%)	58
Low PWM (%)	42

Indoor Fan PWM Limits	
High PWM Limit	99
Low PWM Limit	36

EVV160S / EFV160S : Three Speed Application Fan Curve

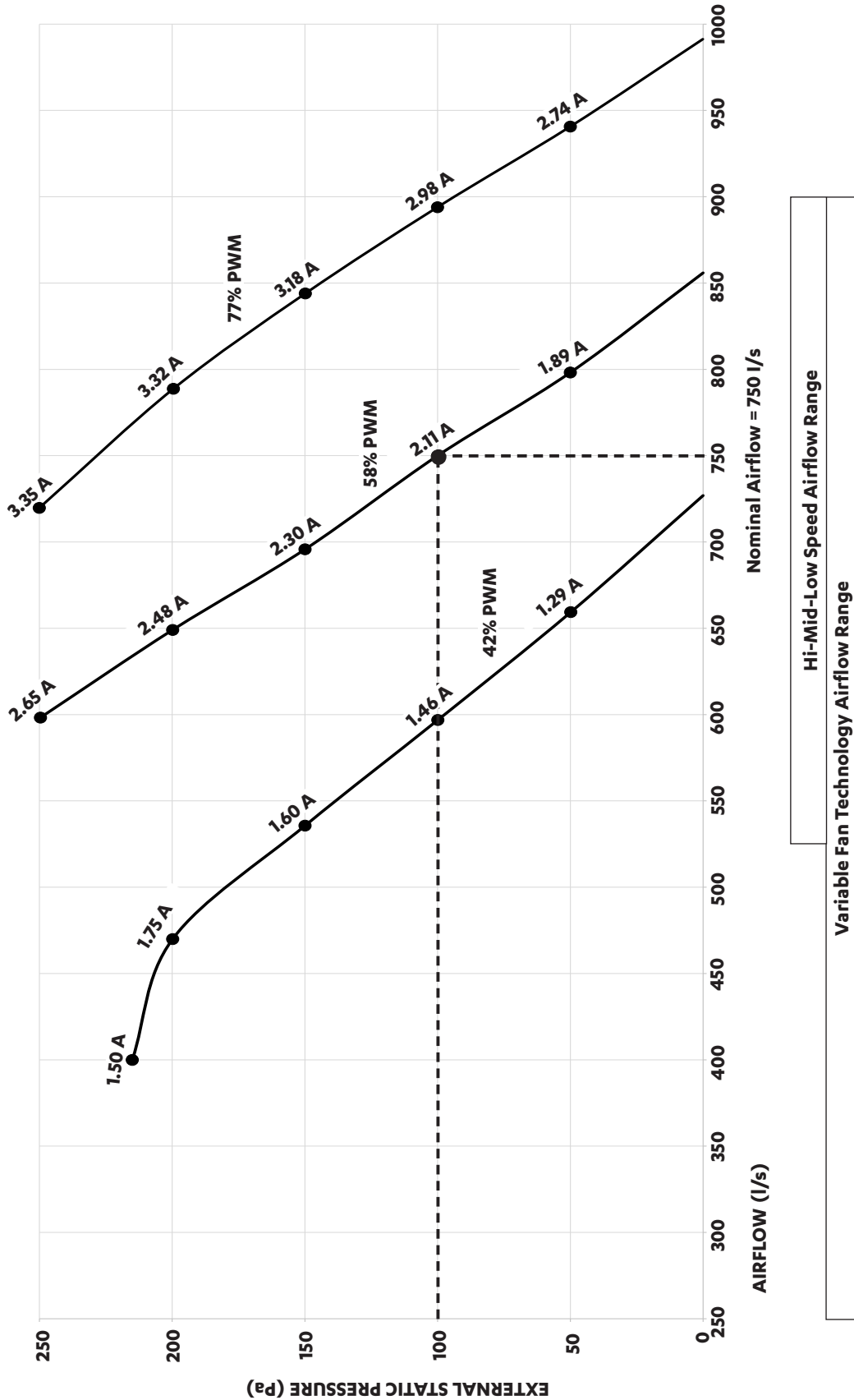

Variable Fan Technology Airflow Range

Hi-Mid-Low Speed Airflow Range

EVV160S / EFV160S : Third Party Application Fan Curve

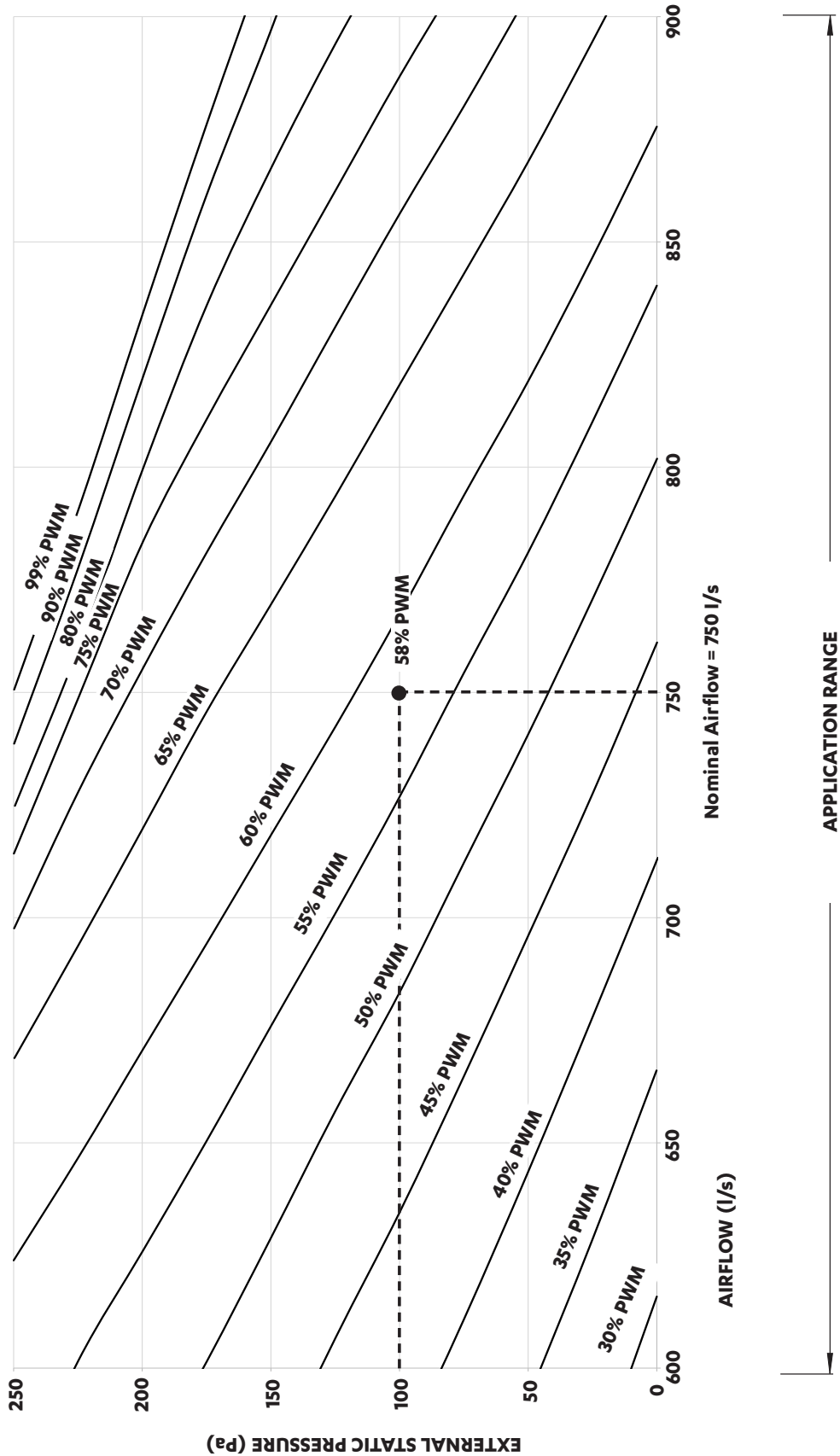

EVV180S / EFV180S

APPLICATION RANGE (COMPRESSOR ON) *										
AIRFLOW (l/s)	EXTERNAL STATIC PRESSURE (Pa)									
	50		100		150		200		250	
	% PWM	W	% PWM	W	% PWM	W	% PWM	W	% PWM	W
680	43	184	50	250	56	317	61	385	67	452
700	45	192	52	266	58	334	63	400	70	471
750	51	228	58	304	63	372	69	446	99	535
800	57	262	63	340	69	419	80	505	MOTOR / BLOWER UNIT	
850	63	305	69	386	78	484				
900	69	348	77	440	91	540				
950	77	404	85	498						
1000	85	461								
1020	89	486								

NOTES

* Only applicable to Third Party controllers

W = Indoor Fan Power, Watts

PWM = Pulse Width Modulation Setting, % PWM (Adjustable through the LR7-1, LC7-2, NEO or Outdoor Board).

Default Fan Speed Value at 100 Pa	
Speed	Default PWM (adjustable)
High PWM (%)	99
Medium PWM (%)	69
Low PWM (%)	50

Indoor Fan PWM Limits	
High PWM Limit	99
Low PWM Limit	43

EVV180S / EFV180S : Three Speed Application Fan Curve

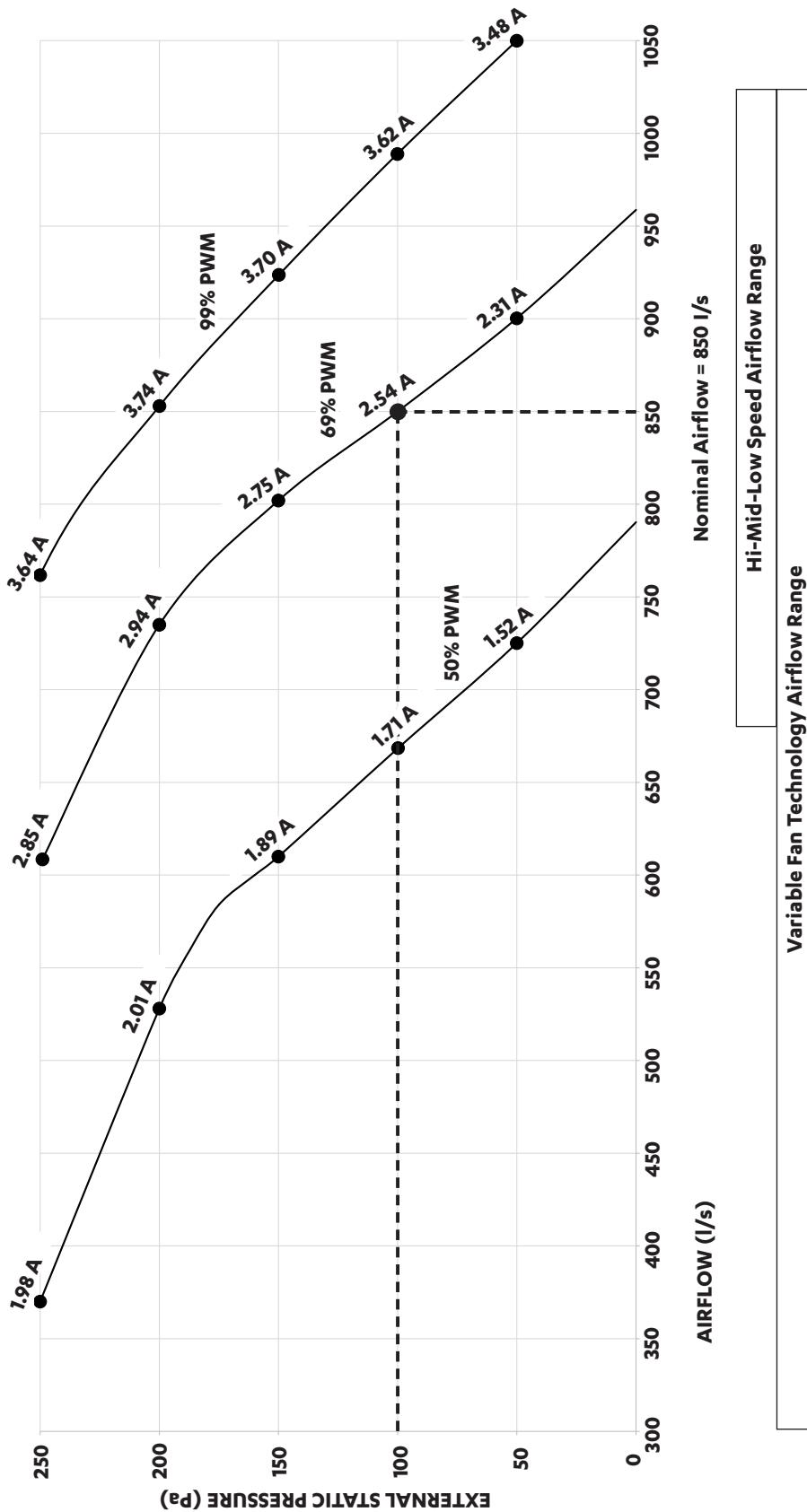

Variable Fan Technology Airflow Range

Hi-Mid-Low Speed Airflow Range

EVV180S / EFV180S : Third Party Application Fan Curve

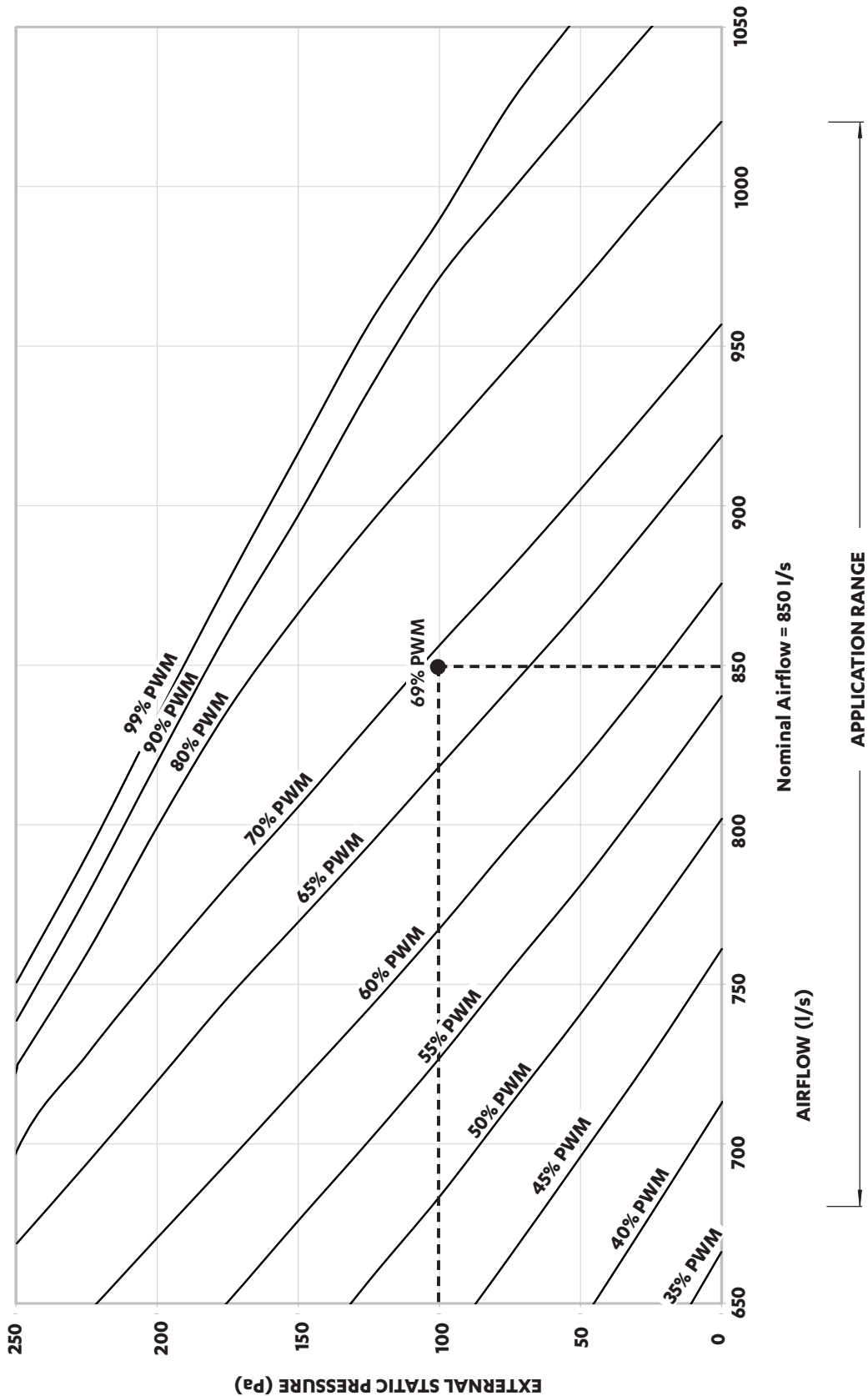

EVV210S / EFV210S

APPLICATION RANGE (COMPRESSOR ON) *												
AIRFLOW (l/s)	EXTERNAL STATIC PRESSURE (Pa)											
	50		100		150		200		250		300	
	% PWM	W	% PWM	W	% PWM	W	% PWM	W	% PWM	W	% PWM	W
810	38	192	43	266	49	333	54	408	59	484	70	561
850	41	214	46	279	51	349	57	437	62	511	74	592
900	45	244	50	313	56	397	61	473	66	548	80	634
950	49	275	54	343	60	431	65	508	71	599	87	688
1000	53	304	59	388	64	464	70	561	75	652	93	739
1020	55	321	61	407	66	485	71	574	77	666	MOTOR / BLOWER UNIT	
1050	58	347	64	436	69	515	73	593	81	694		
1100	63	391	68	467	73	561	79	657	88	750		
1150	68	435	73	527	78	608	84	705	96	817		
1200	72	472	78	571	84	666	90	774				
1230	75	501	82	608	88	710	93	810				

NOTES

* Only applicable to Third Party controllers

W = Indoor Fan Power, Watts

PWM = Pulse Width Modulation Setting, % PWM (Adjustable through the LR7-1, LC7-2, NEO or Outdoor Board).

Default Fan Speed Value at 100 Pa	
Speed	Default PWM (adjustable)
High PWM (%)	82
Medium PWM (%)	61
Low PWM (%)	43

Indoor Fan PWM Limits	
High PWM Limit	99
Low PWM Limit	38

EVV210S / EFV210S : Three Speed Application Fan Curve

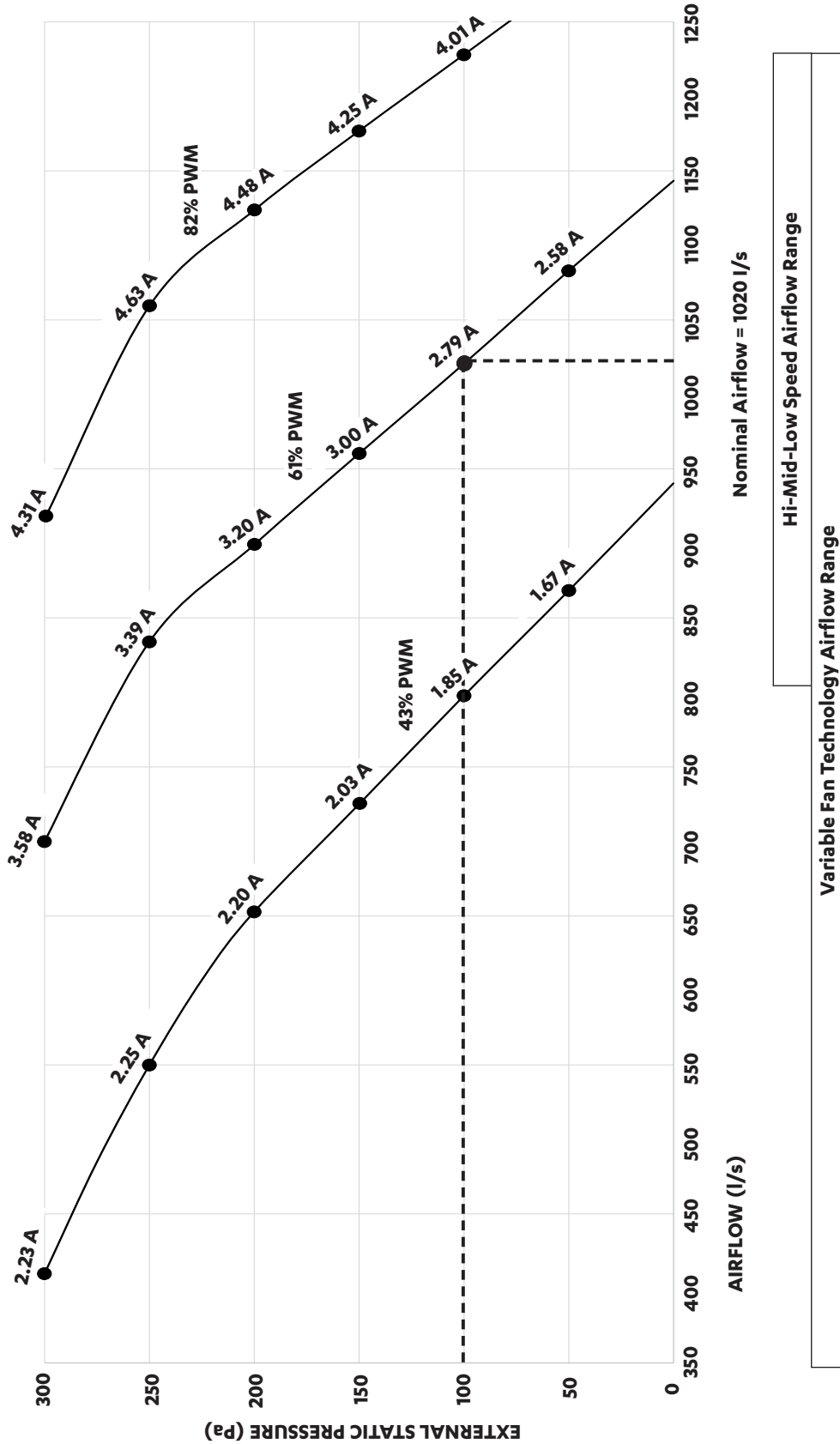

Nominal Airflow = 1020 l/s

Variable Fan Technology Airflow Range

Hi-Mid-Low Speed Airflow Range

EVV210S / EFV210S : Third Party Application Fan Curve

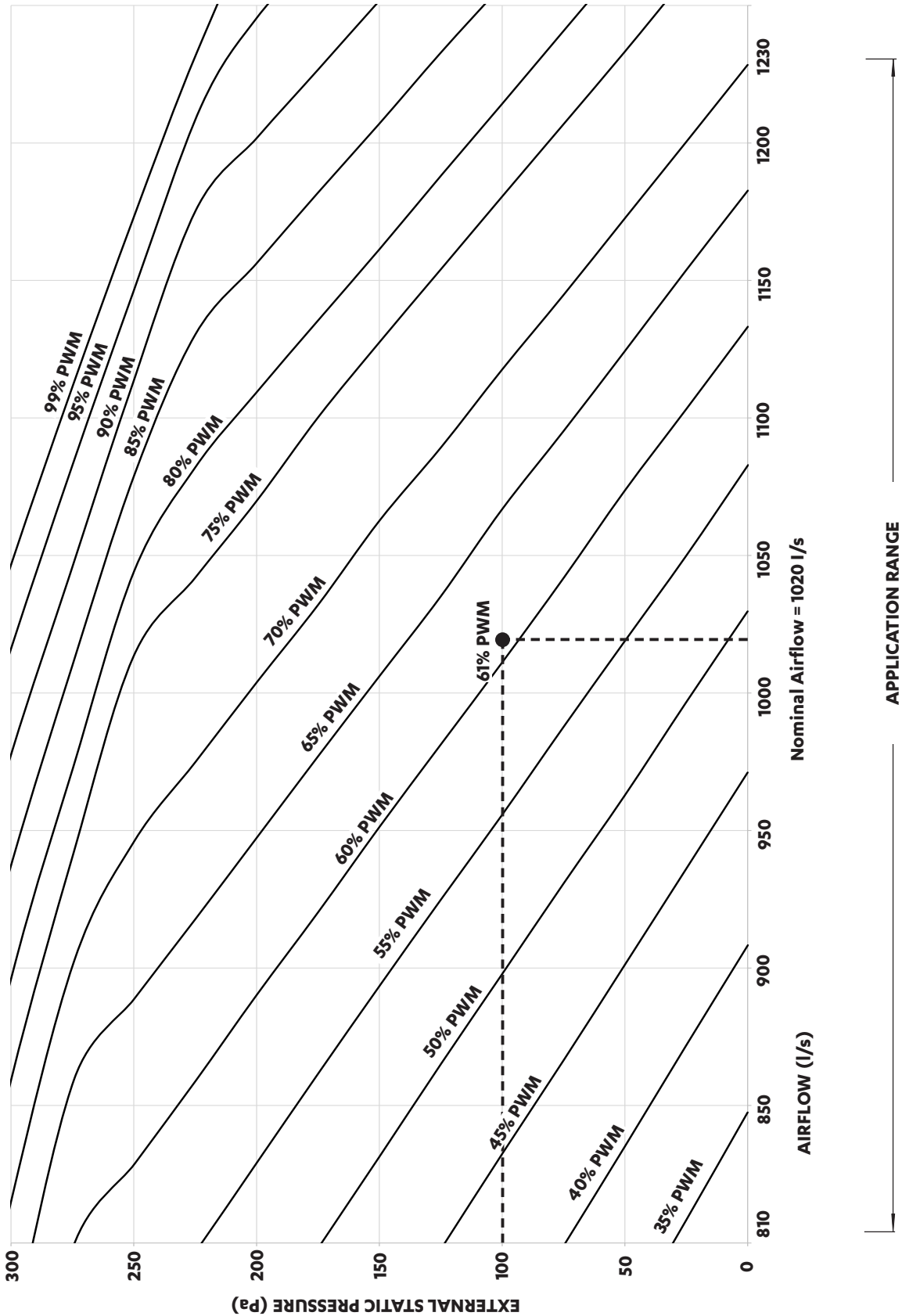

EVV240S / EFV240S

APPLICATION RANGE (COMPRESSOR ON) *														
AIRFLOW (l/s)	EXTERNAL STATIC PRESSURE (Pa)													
	50		100		150		200		250		300		350	
	% PWM	W	% PWM	W	% PWM	W	% PWM	W	% PWM	W	% PWM	W	% PWM	W
900	40	292	44	359	48	440	52	515	59	596	78	684	98	739
950	43	321	47	394	52	491	56	567	66	650	84	741		
1000	47	365	51	441	55	522	59	606	73	707	93	794		
1050	51	410	55	490	59	575	64	669	79	765	99	828		
1100	55	456	59	541	63	629	69	726	87	826				
1130	57	485	62	579	66	673.2	73	767.6	92	861.4				
1150	59	504	63	592	68	703	76	795	96	885				
1200	63	554	68	663	73	771	84	868						
1250	68	622	73	736	78	834	93	924						
1300	73	692	78	810	84	912								
1350	78	762	83	882	92	970								
1360	79	777	84	894	94	989								

MOTOR / BLOWER UNIT

NOTES

* Only applicable to Third Party controllers

W = Indoor Fan Power, Watts

PWM = Pulse Width Modulation Setting, % PWM (Adjustable through the LR7-1, LC7-2, NEO or Outdoor Board).

Default Fan Speed Value at 100 Pa	
Speed	Default PWM (adjustable)
High PWM (%)	84
Medium PWM (%)	62
Low PWM (%)	44

Indoor Fan PWM Limits	
High PWM Limit	99
Low PWM Limit	39

EVV240S / EFV240S : Three Speed Application Fan Curve

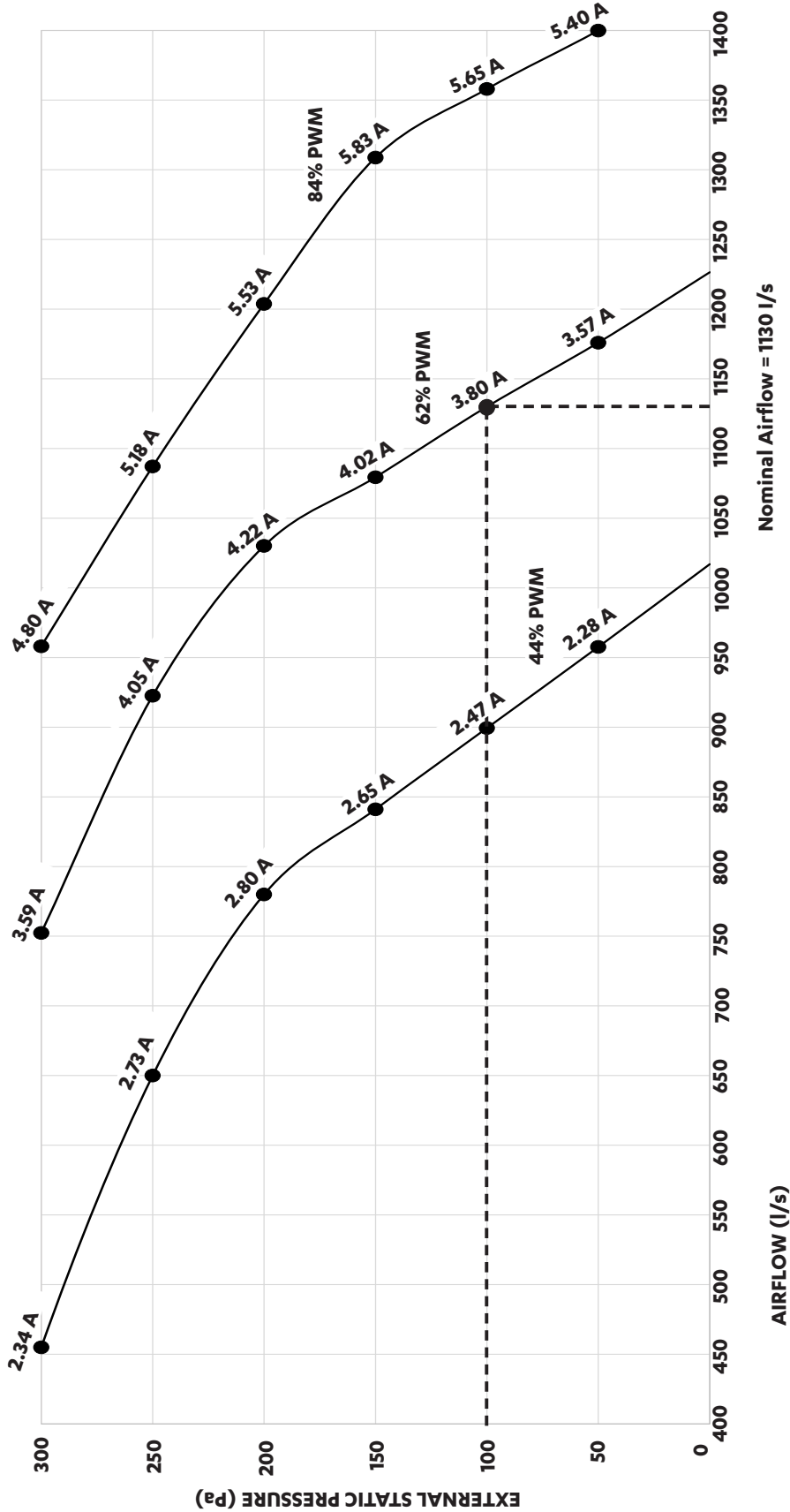

Hi-Mid-Low Speed Airflow Range

Variable Fan Technology Airflow Range

EVV240S / EFV240S : Third Party Application Fan Curve

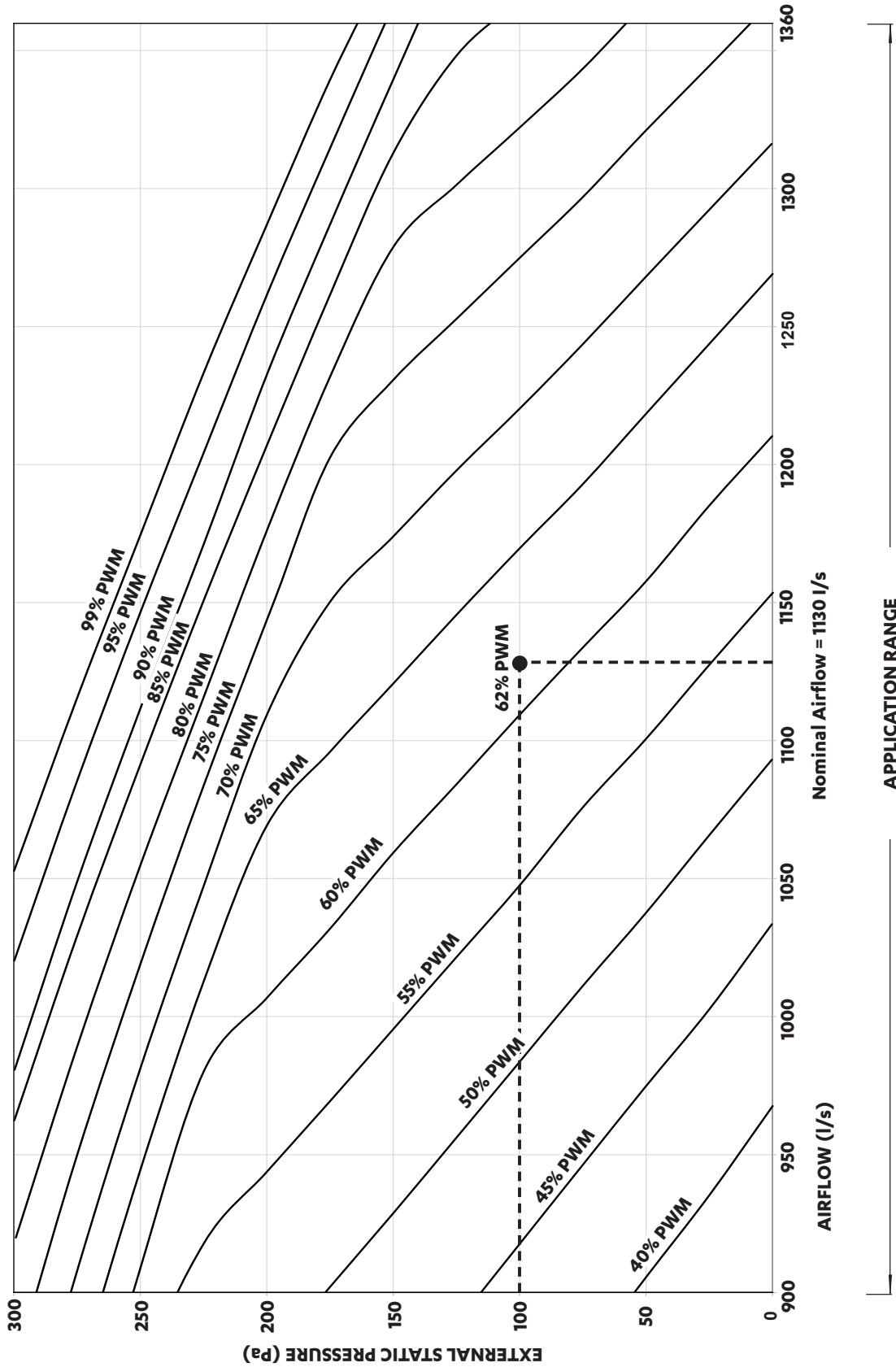

Refrigerant Charging

- The units detailed on this guide are pre-charged with R-410A refrigerant. Should there be a need to add or remove some refrigerant, it is recommended to follow the charging method explained below.
- Never allow R-410A refrigerant to vent into the atmosphere. It is an offence to release refrigerant in Australia. Always reclaim refrigerant using equipment and container dedicated for R-410A system use only.
- All work must be carried out in accordance with Australia and New Zealand refrigerant handling code of practice.
- Only qualified personnel are allowed to perform any work described in this guide and specifically work related to addition or removal of refrigerant.
- R-410A refrigerant must always be charged in liquid state.
- Only during the compressor running condition can the system be charged through the suction service port on the compressor suction line.
- Changes in refrigerant charge must be noted to a label that is fixed to the unit for future reference.

CAUTION

R-410A refrigerant has POE oil that rapidly absorbs moisture. The maximum time any system can be opened to atmosphere is 15 minutes.

Charging Method: Subcooling and Superheat

Parameters:

LLT = Liquid Line Temperature

SLT = Suction Line Temperature

SCT = Saturated Condensing Temperature

SST = Saturated Suction Temperature

Cooling and Heating Operation:

Adjust the refrigerant charge to obtain the correct super heat and sub-cool for optimal performance as follows:

1. Ensure that air filters are fitted and total system airflows are achieved. (Air filters are not supplied with the unit, it is the responsibility of the installing contractor to provide and fit adequate return air and fresh air filters).
2. Connect service gauges to the shut off valves.
3. Start the unit in cool mode ensuring that the compressor is in operation before taking service gauges reading. Allow the system to stabilise for next 15 - 30 minutes before recording.
4. Record the discharge pressure, suction pressure, liquid line temperature and suction line temperature for all the refrigeration circuits.

Discharge Pressure = _____ kPa

Suction Pressure = _____ kPa

Liquid Line Temperature (**LLT**) = _____ °C

Suction Line Temperature (**SLT**) = _____ °C

NOTES

- Accurate pressure and temperature measuring tools should be used to achieve satisfactory results.
- The sensors of thermocouple must be in good contact with the area being measured and must be insulated in order to obtain correct reading.
- For illustration purpose only. Valve location may vary depending on unit model.

See Diagram Below:

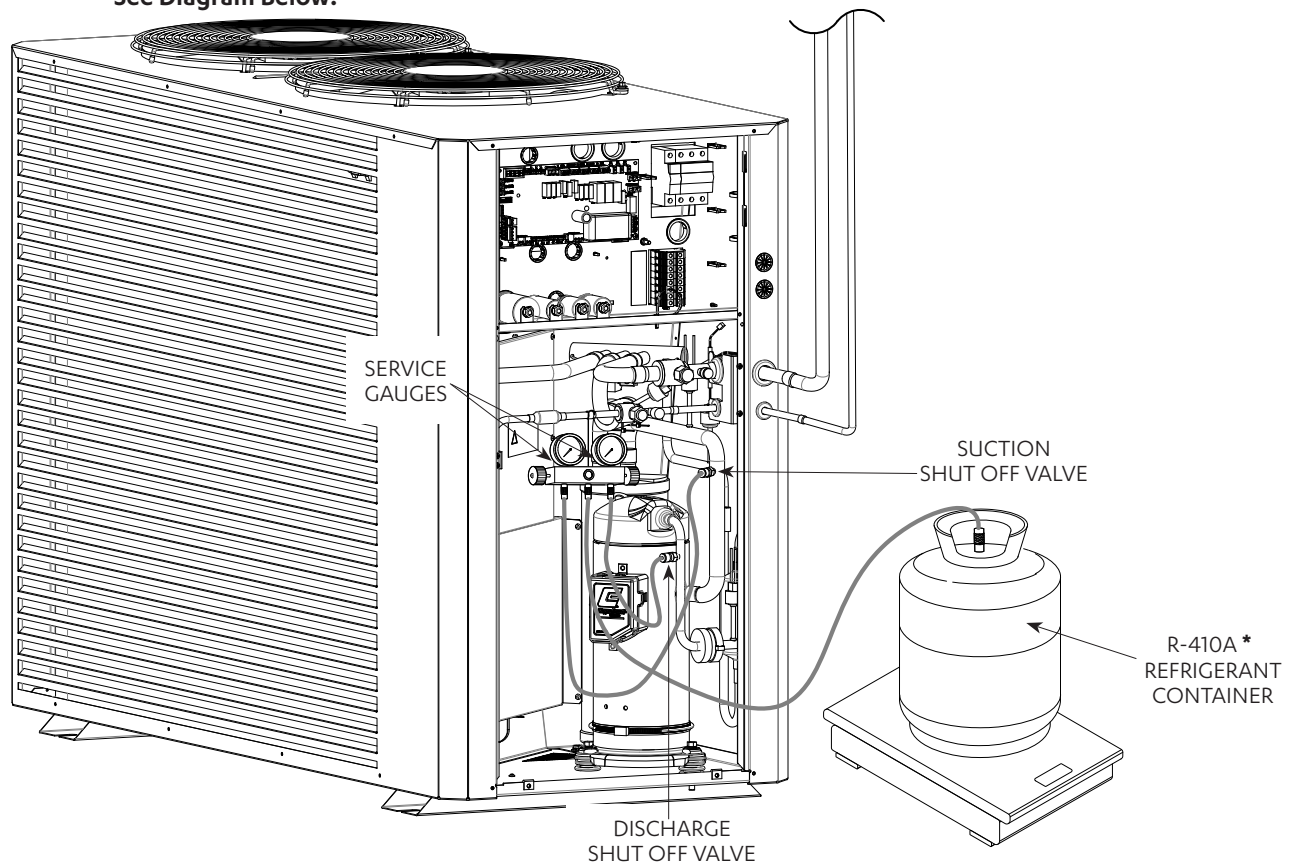

* Use weighing scale when adding or removing refrigerant charge.

Checking for Subcooling

1. From the R-410A Pressure / Temperature Chart record the corresponding Saturated Condensing Temperature (**SCT**) at the given discharge pressure.
2. Calculate the system subcooling using the formula below:

$$\text{Subcooling} = \text{SCT} - \text{LLT}$$
3. If subcooling is within the range (see charging table), there is no need to add/remove refrigerant.
 - If subcooling is lower than minimum, the system is undercharged, it is necessary to add refrigerant.
 - If subcooling is higher than maximum, the system is overcharged, it is necessary to remove refrigerant.

Allow the systems to stabilise (15 - 30 mins) and repeat the steps 1-3 until subcooling falls within the range specified in the Subcooling/Superheat Table below.

Checking for Superheat

Maintaining the correct superheat is important for ensuring the evaporator is achieving maximum capacity and avoiding excessive liquid refrigerant returning to the compressor.

1. From the R-410A Pressure/Temperature Chart record the corresponding Saturated Suction Temperature (**SST**) at the given suction pressure.
2. Calculate the system super heat using the formula below:

Superheat = SLT -SST

3. If superheat is within the range (see charging table), there is no need to add/remove refrigerant.
 - If superheat is lower than minimum, it means that liquid refrigerant may be returning to compressor. It is necessary to remove refrigerant or check EEV settings.
 - If superheat is higher than maximum, it means that refrigeration capability of evaporator is not fully maximised. It is necessary to add refrigerant charge or check EEV settings.

Allow the systems to stabilise (15 - 30 mins) and repeat the steps 1-3 until superheat falls within the range specified in the table below.

Subcooling/Superheat Table			
Cooling		Heating	
Subcooling	Superheat	Subcooling	Superheat
4 - 8	2 - 8	10 - 14	2 - 8

NOTES

The above subcooling and superheat recommendations are based on the following rated conditions:

- Cooling: 35°C DB outdoor, air entering indoor at 27°C DB / 19°C WB.
- Heating: 7°C DB / 6°C WB outdoor, air entering indoor at 20°C DB Nominal indoor airflow.

CHARGING TABLE

Temp °C	Pressure KPa	Temp °C	Pressure KPa	Temp °C	Pressure KPa	Temp °C	Pressure KPa
-60	-34.4	-28	194.9	4	805.9	36	2090.7
-59	-30.7	-27	206.9	5	834.1	37	2145.5
-58	-26.8	-26	219.2	6	862.9	38	2201.3
-57	-22.8	-25	231.9	7	892.6	39	2258.2
-56	-18.6	-24	245.1	8	922.8	40	2316.1
-55	-14.2	-23	258.7	9	953.8	41	2375.1
-54	-9.6	-22	272.6	10	985.4	42	2435.1
-53	-4.8	-21	286.9	11	1017.8	43	2496.2
-52	0.8	-20	301.7	12	1050.9	44	2558.5
-51	5.3	-19	316.9	13	1084.7	45	2621.8
-50	10.7	-18	332.6	14	1119.2	46	2686.2
-49	16.3	-17	348.7	15	1154.6	47	2751.8
-48	22.2	-16	365.2	16	1190.7	48	2818.5
-47	28.2	-15	382.3	17	1227.5	49	2886.4
-46	34.0	-14	399.7	18	1265.2	50	2955.5
-45	40.9	-13	417.7	19	1303.6	51	3025.7
-44	47.8	-12	436.2	20	1342.9	52	3097.2
-43	54.8	-11	455.1	21	1382.9	53	3169.9
-42	62.1	-10	474.6	22	1423.9	54	3243.7
-41	69.6	-9	494.6	23	1465.7	55	3318.9
-40	77.4	-8	515.1	24	1508.3	56	3395.2
-39	85.5	-7	536.2	25	1551.8	57	3472.9
-38	93.9	-6	557.8	26	1596.2	58	3551.8
-37	102.5	-5	579.9	27	1641.4	59	3631.9
-36	111.5	-4	602.6	28	1687.6	60	3713.5
-35	120.8	-3	625.9	29	1734.6	61	3796.3
-34	130.4	-2	649.8	30	1782.6	62	3880.5
-33	140.3	-1	674.3	31	1831.6	63	3965.9
-32	150.5	0	699.4	32	1881.5	64	4052.8
-31	161.1	1	724.9	33	1932.3	65	4140.9
-30	171.9	2	751.3	34	1984.1	66	4230.6
-29	183.3	3	778.3	35	2036.9	67	4321.5

Specifications for Refrigeration

TABLE : REFRIGERATION PIPING - SINGLE PHASE				
Reverse Cycle (Outdoor / Indoor)		CRV140S / EVV140S	CRV160S / EVV160S	CRV180S / EVV180S
Max. Equivalent Pipe Length Range	metres	0 - 60	0 - 60	0 - 60
Max. Vertical Height Differential ⁽¹⁾	metres	20	20	20
Field Pipe Size				
Liquid Line	inch (mm)	3/8 (9.52)	3/8 (9.52)	3/8 (9.52)
Gas Line	inch (mm)	3/4 (19.05)	3/4 (19.05)	3/4 (19.05)
Outdoor Pipe Size				
Liquid Line	inch (mm)	3/8 (9.52) swaged	3/8 (9.52) swaged	3/8 (9.52) swaged
Gas Line	inch (mm)	3/4 (19.05) swaged	3/4 (19.05) swaged	3/4 (19.05) swaged
Indoor Pipe Size				
Liquid Line	inch (mm)	3/8 (9.52) swaged	3/8 (9.52) swaged	3/8 (9.52) swaged
Gas Line	inch (mm)	3/4 (19.05) swaged	3/4 (19.05) swaged	7/8 (22.22) ⁽²⁾ swaged

NOTES

⁽¹⁾ Included in maximum field pipe length.

⁽²⁾ Cut swaged end on the unit to fit field pipe.

TABLE : REFRIGERATION PIPING - THREE PHASE					
Reverse Cycle (Outdoor / Indoor)		CRV160T / EVV160S	CRV180T / EVV180S	CRV210T / EVV210S	CRV240T / EVV240S
Max. Equivalent Pipe Length Range	metres	0 - 60	0 - 60	0 - 60	0 - 60
Max. Vertical Height Differential ⁽¹⁾	metres	20	20	20	20
Field Pipe Size					
Liquid Line	inch (mm)	3/8 (9.52)	3/8 (9.52)	3/8 (9.52) or 1/2 (12.7) ^{(2) (3)}	1/2 (12.7)
Gas Line	inch (mm)	3/4 (19.05)	3/4 (19.05)	7/8 (22.2) or 1 (25.4) ^{(2) (3)}	1 (25.4)
Outdoor Pipe Size					
Liquid Line	inch (mm)	3/8 (9.52) swaged	3/8 (9.52) swaged	1/2 (12.7) ⁽²⁾ swaged	1/2 (12.7) swaged
Gas Line	inch (mm)	3/4 (19.05) swaged	3/4 (19.05) swaged	7/8 (22.2) swaged	7/8 (22.2) swaged
Indoor Pipe Size					
Liquid Line	inch (mm)	3/8 (9.52) swaged	3/8 (9.52) swaged	1/2 (12.7) ⁽²⁾ swaged	1/2 (12.7) swaged
Gas Line	inch (mm)	3/4 (19.05) swaged	7/8 (22.2) ⁽²⁾ swaged	1 (25.4) swaged	1 (25.4) swaged

NOTES

⁽¹⁾ Included in maximum field pipe length.

⁽²⁾ Cut swaged end on the unit to for field pipe, if required.

⁽³⁾ For pipe runs 20-60m 1/2" and 1" pipe must be used.

Refrigerant Charge Details (R-410A)									
Model		CRV140S	CRV160S	CRV180S	CRV160T	CRV180T	CRV210T		CRV240T
Refrigerant Type		R-410A	R-410A	R-410A	R-410A	R-410A	R-410A		R-410A
Factory Charge	gms	5580	6300	7580	6200	7850	7400		9350
Pre- charged Length *	m	15	15	15	15	15	15		15
Additional Refrigerant per charge	gms	50	50	50	50	50	50	100	100
Field Pipe Sizing In.(mm)	LIQ.	3/8" (9.52)	3/8" (9.52)	3/8" (9.52)	3/8" (9.52)	3/8" (9.52)	3/8" (9.52) ⁽¹⁾	1/2"(12.7)	1/2"(12.7)
	GAS	3/4" (19.05)	3/4" (19.05)	3/4" (19.05)	3/4" (19.05)	7/8" (22.22)	7/8" (22.22)	1" (25.4)	1" (25.4)

* **Note:** If the installation is less than 15m, reduce refrigerant charge by 40g per meter.

NOTE

⁽¹⁾ 50grams per meter is only applicable if 3/8" liquid field pipe is used (for field pipe length between 0-20m).

Maintenance

Maintenance Procedures

This section describes the procedures that must be performed as a part of normal maintenance program. Regular servicing of equipment by licensed technician is highly recommended. Regular servicing of your unit helps in maintaining its optimum performance and reliability. **The checklist and service periods provided on this manual are guides only, as some sites may require more frequent servicing.** Always disconnect electrical power to the unit before performing these procedures unless otherwise required. It is always a safe practice to observe all safety warnings and cautions when conducting maintenance tasks.



DANGER

Live Electrical Connections!

It may be necessary to work with live electrical components on certain maintenance tasks. Only licensed electricians and qualified technicians are allowed to perform these tasks.

Beware of Rotating Fan Blades!

Always make sure that all power supplied to the fans are turned Off and isolated.

Observe WH&S safety procedures, do not wear loose clothing and any jewellery when working near the fans.

Wear PPE whenever performing any maintenance procedures.

Observe all necessary procedures when working on a confined space.



WARNING

Hazardous Voltage!

Always make sure that all power supply, including remote controls, are disconnected before performing maintenance.

Observe proper LOCK-OUT/TAG-OUT procedures to ensure that power cannot be inadvertently energised. Failure to disconnect power before maintenance procedures can result in serious injury and/or death.

EC Motors are fitted with high power capacitors and can have dangerous residual voltages at motor terminals after power has been isolated. Wait at least 5 minutes after power isolation and test for any residual voltage before beginning service work.

Annual Maintenance Checklists

- Perform general maintenance inspections.
- Perform scheduled start-up checks.
- Leak test refrigerant circuits.
- Inspect contacts of all contactors and relays. Replace all worn contacts as required.
- Inspect, clean and tighten all electrical connections.
- Check fans for balanced operation. Make sure that there are no loose screws / bolts, no fan blades interference and no damage to the fans and guards.
- Inspect the air filters, clean or replace as required.
- Clean and repaint any corroded panel section.
- Ensure no blockage of airflow through variable speed drive.

Cleaning the Condenser Coils

Clean the coils at least once a year or more frequently if unit is located in a dusty and dirty environment, in order to maintain your system's proper operating performance. High discharge pressures are good indication that the coils need cleaning. When using detergent or solvents to clean the coils, follow the manufacturer's instructions to avoid potential damage to the coils and to the unit.

To clean the refrigerant coils, use a soft brush and water spray, such as garden hose or pressure washer with low pressure nozzle.

 **WARNING****Do Not Use High Alkaline Detergent!**

When using detergent for coil cleaning, ensure that the alkaline level is no higher than 8.5, which can cause corrosion damage to the coils.

 **DANGER****No Water into the Electrical Compartments!**

Ensure consideration is given to the possibility of water entering the electrical compartments during cleaning of the condenser coil.

Coil Cleaning Procedures

- Disconnect power to the unit.
- Remove the louvered panels from the unit to gain access to the air inlet side of the coils.
- Use a soft brush to remove loose dirt and debris from both sides of the coils.
- Straighten bent coil fins with fin comb.
- Prepare the detergent solutions according to the manufacturer's instructions.
- Spray solution at a 90° angle to the coils, keeping a minimum nozzle spray angle of 15°, with at least a 1800mm distance from the coils and 600 psi pressure.
- Spray leaving air side of the coils first then the air inlet side. Allow the solution to stand on the coils for five minutes.
- Rinse both sides of the coils with cool clean water.
- Inspect the coils, if they are still dirty, repeat the cleaning procedure.
- Clean and wipe dry the outer and inner sides of the unit, the refrigerating parts and other components.
- Ensure that the condensate drain lines are not blocked.
- Reinstall all unit panels, covers and guards.
- Restore electrical power to the unit.

Maintenance Frequency Checklist

Regular servicing of equipment by a qualified technician is recommended every 12 months for residential applications and every quarter for commercial applications. Regular servicing of your unit helps in maintaining its optimum performance and reliability. **The following checklist and service periods are provided as a guide only, as some sites may require more frequent servicing.**

ELECTRICAL											
Parts	Service Period					Detail of Service Check	Service Methods				
	1 Mth	3 Mth	6 Mth	1 Yr	2 Yrs			3 Yrs	4 Yrs	5 Yrs	
Printed Circuit Boards				✓						Visual Inspection	Tighten Terminals as necessary on printed circuit boards
Electrical Connections				✓						Check all electrical terminals, mains, communications, etc	Re-tighten if loose.

OUTDOOR UNIT											
Parts	Service Period					Detail of Service Check	Service Methods				
	1 Mth	3 Mth	6 Mth	1 Yr	2 Yrs			3 Yrs	4 Yrs	5 Yrs	
Casing / Panels and Frames				✓						Visual check for damage, rust and dust accumulation.	For highly corrosive environment, wash panels quarterly with water and neutral detergent solution. Wax panels. Repair / re-paint where required.
Insulation				✓						Visual check for insulation conditions.	Repair / replace insulation material.
Fan				✓						Visual check for run out of balance and dust attached	Clean off dust as necessary to negate possibility of fan running out of balance
Motor				✓ Ω						Visual check on wiring. Insulation resistance check to be carried out annually	Measure insulation resistance. Should be more than 1MΩ
Heat Exchanger				✓						Check for clogging by dust. Check for leaks / damage.	Clean air inlet side as necessary. Straighten any bent fins using fins comb.
Condensate Drain Line (if available)				✓						Check for obstructions and free flow of water	Clean to eliminate obstructions/sludge and check condition of drain line. Pour water to ensure free flow.
Compressor				✓ Ω						Check for high / low pressure. Measure insulation resistance. Check compressor for abnormal noise/vibrations	Measure insulation resistance. Should be more than 1MΩ.
Refrigeration Operational Readings				✓						Make note of operational reading in test cool/heat	Check operating pressures, record superheat and subcooling values
Safety Devices				✓						Check calibration of safety devices such as HP and LP controls, sensors, etc	Check resistance of sensors, pressure cut in / cut out of pressure controls
Faults				✓						Check for any previous fault history on unit.	Investigate any causes for previous faults, reset fault history.

Version History

DOCUMENT VERSION	BOM VERSION	MODEL NUMBERS	UPDATE HISTORY
Ver 3	-0100	All	Released
Ver 4	-0100	All	Updated the WD and Wiring Connections with Ferrite Clips and Neo Zone and Neo Sense.
Ver 5	-0100	CRV140-180S CRV160-180T	No change
	-0200	CRV210-240T	Change in VSD
Ver 6	-0100	All	Included note to reduce the refrigerant charge if the installation is less than 15m.
Ver 7	-0100	All	Added Safety Precautions Information and Updated Pressure Testing



©Copyright 2020 Actron Engineering Pty Limited ABN 34 002767240. ®Registered Trade Marks of Actron Engineering Pty Limited.
ActronAir is constantly seeking ways to improve the design of its products. Therefore, specifications are subject to change without notice.