

# Package Tri-Capacity

## Installation and Commissioning Guide

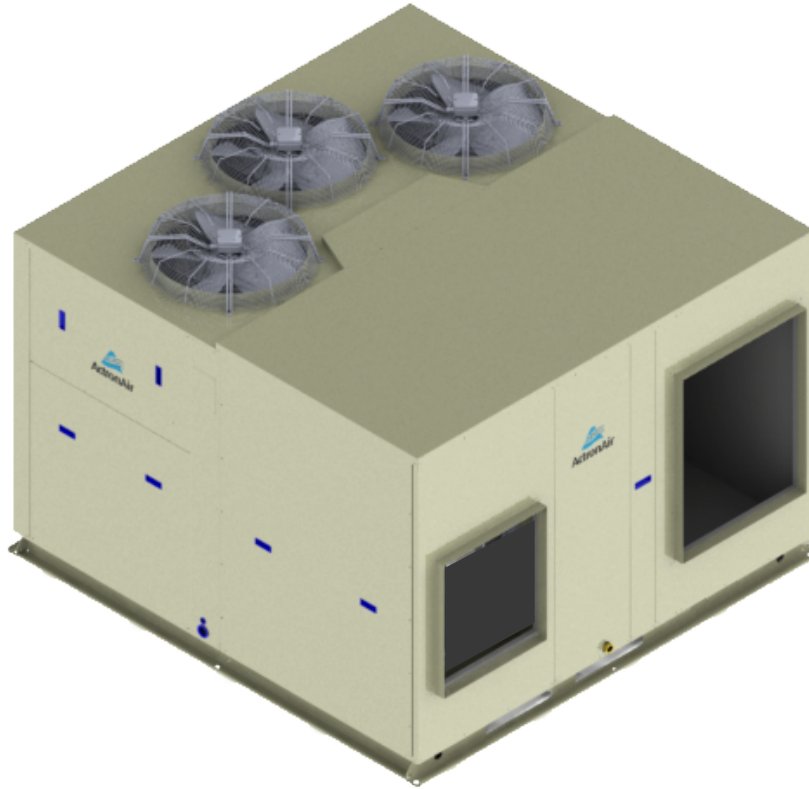

### Model Numbers

PKY500T

PKY620T

PKY700T

### **IMPORTANT NOTE:**

Please read this manual carefully before installing or operating your air conditioning unit.



## TABLE OF CONTENTS

<b>01. INTRODUCTION .....</b>	<b>4</b>
01.01. Product Inspections .....	4
01.02. Codes, Regulations and Standards .....	4
<b>02. GENERAL INFORMATION.....</b>	<b>4</b>
<b>03. SAFETY PRECAUTION .....</b>	<b>6</b>
<b>04. INSTALLATION INFORMATION .....</b>	<b>7</b>
<b>05. UNIT MOUNTING AND LOCATION .....</b>	<b>8</b>
<b>06. INSTALLATION INSTRUCTIONS .....</b>	<b>9</b>
<b>07. COMPONENTS OVERVIEW.....</b>	<b>10</b>
<b>08. UNIT DIMENSIONS.....</b>	<b>11</b>
08.01. PKY500T .....	11
08.02. PKY620T .....	12
08.03. PKY700T .....	13
08.04. Base Mounting Details .....	14
08.05. Service Access Areas and Airflow Clearances .....	15
<b>09. UNIT LIFTING PROCEDURES.....</b>	<b>16</b>
09.01. Crane Lifting Method .....	16
09.02. Fork Lift Method .....	17
<b>10. CONDENSATE DRAINAGE INSTRUCTIONS.....</b>	<b>18</b>
10.01. Suggested Minimum Slope to Ensure Correct Drainage .....	18
10.02. Suggested Drain Trap Details .....	19
<b>11. BANKING OF UNITS .....</b>	<b>20</b>
11.01. End-To-End Configuration .....	20
11.02. Cluster Configuration .....	20
11.03. Side-By-Side Configuration .....	21
11.04. End-To-End Configuration .....	21
11.05. Standard Model .....	22
11.06. Standard Model with Optional 3-Phase Protection Relay .....	22
11.07. Standard Model with Optional 3-Phase Soft Starters .....	23
11.08. With Optional EC Outdoor Fans .....	24
11.09. With Optional EC Outdoor Fans and 3-Phase Protection Relay .....	24
11.10. With Optional EC Outdoor Fans and 3-Phase Soft Starters .....	25
<b>12. UNIT PREPARATION.....</b>	<b>26</b>
12.01. Supply and Return Angle Plate Installation .....	26
12.02. Supply and Return Angle Plate Assembly/Installation .....	27
12.03. Electrical Mains and Isolator Installation .....	28
12.04. Compressor Shipping Blocks Removal .....	29
12.05. Air Filter Installation .....	30
<b>13. ELECTRICAL.....</b>	<b>31</b>
13.01. Package Electrical Connection .....	31
13.02. Maximum Cable Lengths .....	32
13.03. BMS Control Wiring Procedures .....	33
13.04. Return Air - Outside Air - Spill Air Control Wiring Procedures .....	34
13.05. Demand Response Management .....	35
<b>14. CONTROL MENU .....</b>	<b>36</b>
14.01. Menu Navigation .....	36
14.02. Service Password .....	36

**15. MENU TREE ..... 37**  
 15.01. Main/Status Menu 37  
 15.02. Service Menu 38  
 15.03. Manufacturer Menu 40

**16. EXTERNAL INPUT OPERATION ..... 41**  
 16.01. Unit ON/OFF Configuration 41  
 16.02. Indoor Fan External Control 41  
 16.03. Compressor Configuration 43

**17. INTERNAL SENSOR OPERATION.....46**  
 17.01. Unit Control Configuration 46  
 17.02. Unit ON/OFF Configuration 46  
 17.03. Indoor Fan Configuration 49

**18. SETTING UP BMS (REMOTE DEMAND) OPTIONAL ..... 50**

**19. SETTING ECONOMY CYCLE OPERATION ..... 50**  
 19.01. Setting Economy Cycle Type 50

**20. ROOM AIR TEMPERATURE SENSOR INSTALLATION ..... 52**

**21. ROOM AIR TEMPERATURE SETUP IN CONTROL INTERFACE .....53**  
 21.01. Averaging Four Room Air Temperature Sensors (Optional) 53  
 21.02. Setting up the Room Air Temperature 54  
 21.03. Room Temperature Sensor Adjustment Instructions 54

**22. AFTER HOURS LOGIC WITH TIMECLOCK (SCHEDULER) ..... 54**  
 22.01. After Hours wiring to the unit 54  
 22.02. Operational Logic 55

**23. ENABLE / DISABLE AIR FILTER ALARM .....55**

**24. EXTERNAL INPUT WIRING DIAGRAMS..... 56**  
 24.01. 24VAC Relay Output Compressors and Indoor Fans 56  
 24.02. 0-10 Analogue Output Compressor and 24VAC Relay Output Indoor Fans 57  
 24.03. 24VAC Relay Output Compressor and 0-10 Analogue Output Indoor Fans 58  
 24.04. Wiring Diagram 0-10 Analogue Output Compressors and Indoor Fans 59

**25. FAN PERFORMANCE DATA AND CURVE .....60**

**26. REFRIGERANT CHARGING ..... 63**  
 26.01. Charging Method 1: Subcooling and Superheat 63  
 26.02. Charging Method 2: Cooling Charging Curve 67  
 26.03. Thermal Expansion Valve (TXV) Adjustment 68

**27. FAULT DISPLAY CODES..... 69**  
 27.01. Control Fault Code Displays 69  
 27.02. Soft Starter Display Codes 70

**28. MAINTENANCE .....71**

**29. MAINTENANCE FREQUENCY CHECKLIST ..... 73**

**30. SENSOR DETAIL .....75**

**31. START-UP AND COMMISSIONING REPORT ..... 76**

## 01. INTRODUCTION

### 01.01. Product Inspections

Check your air conditioning unit and all items against the invoice upon receiving your shipment. Inspect the unit, components and accessories for any sign of damage. If there is any damage to the unit, contact ActronAir Customer Care Department immediately on: **1300 522 722** to obtain a Return Material Authorisation (RMA).

Check the unit nameplate to verify the model, serial number, electrical rated specifications are correct.

### 01.02. Codes, Regulations and Standards

The installer and/or contractor assumes responsibility to ensure that unit installation complies with the relevant council, state / federal codes, regulations and building code standards. All electrical wiring must be in accordance with current electrical authority regulations and all wiring connections to be as per electrical diagram provided with the unit.

## 02. GENERAL INFORMATION

The ActronAir Ducted air conditioning units are designed for applications where superior performance, high efficiency, reliability, supply air quality and quiet operation are the prime priorities. The units are built with the latest technology, EC indoor fans, low-noise outdoor fans and an intelligent electronic control.

For optimum efficiency, your air conditioning unit will deliver just the right amount of cooling or heating capacity you demand. Even in extreme conditions, the unit will still supply the required demand at peak performance.

### Energy Efficient Refrigeration Circuits

The ActronAir Ducted system is designed with a variable capacity refrigeration circuit that delivers only the amount of cooling or heating actually required to maintain your desired comfort at the most optimum efficiency.

The refrigeration circuit consists of:

- High efficiency scroll compressors
- Hydrophilic coated condenser coil designed for optimum performance and efficiency with corrugated fins and ruffled tubing
- Hydrophilic coated evaporator coil designed for optimum performance and efficiency with lanced fins and ruffled tubing
- Thermal expansion valve (TXV), to maintain efficiency at different operating conditions

### Evaporator Section

The evaporator section has EC fans which deliver just the right amount of airflow, depending on requirements. The fans provide superior performance for your comfort at optimum efficiency:

- Highly efficient variable speed EC motor that uses less energy than the traditional AC motor.
- Capable of high external static pressure application (up to 500 Pa).
- Easy indoor fan commissioning via control interface.
- Low noise operation.

### Condenser Section

- Scroll compressor
- Efficient axial fans with direct drive AC motor
- Low noise operation



## Electrical Section

The electrical section consists of:

- EMC filters
- Switchgears
- 3 Phase motor protection
- 7 Segment Display menu and fault code
- Adjustable indoor airflow pot
- Optional soft start, BMS card, ActronAir Group Control

## Durable Design and Construction

ActronAir is an Australian manufacturer with proven high quality air conditioning products. Known for their durability and reliable performance, these products are designed and built to withstand the extreme weather conditions.

The heavy gauge galvanised steel cabinet, with powder coated Hydrophilic coated finish, resists the toughest conditions. The louvered outdoor coil guard protects the condenser coil from any potential damage brought by hail, stones and other solid objects that may be projected to the unit.

Hydrophilic coated condenser coil fins provide protection to your heat exchangers and enhanced heat transfer with increased performance efficiency.

## System Flexibility

ActronAir units are the first choice for office, schools and other air conditioning facilities applications, both for new construction or retrofitting projects.

## Sustainability and Environmentally Friendly

The air conditioning system is supplied with zero ozone depleting R-410A refrigerant, which has no phase out or replacement concern.

With cooling and heating performance capacity that are among the best in the market, the ActronAir units are the solution for the reduction of energy consumption, CO<sub>2</sub> emission, high fuel dependency and high network grid demand.

## Refrigerant Handling and Accountability

ActronAir strongly urges that all service technicians make every effort possible to reduce the emission of refrigerants to the atmosphere. Everyone must act in a responsible manner to conserve refrigerants in accordance to the industry code of practice.

### 03. SAFETY PRECAUTION

- Only licensed HVAC technicians\* should install and service this air conditioning equipment. Improper service or alteration by an unqualified technician could result in significant and major damage to the product or property which may render your warranty null and void. Such unqualified service could also lead to severe physical injury or death. Follow all safety instructions in this literature and all warning labels that are attached to the equipment.
- Prevailing WH&S regulations must be observed and will take precedence to the safety instructions contained on this manual. Safe work practices and environment must be the paramount importance in the performance of all the service procedures.
- Ensure that unit installation complies with relevant council regulations and building code standards.
- All electrical wiring must be in accordance with current electrical authority regulations and all wiring connections to be as per electrical diagram provided.
- Secure the fans against accidental contact. Beware of pinch point and sharp edges which can cause cutting injury.
- Always wear appropriate PPE, remove any dangling jewellery and protect long hair by wearing a cap.
- Make sure that safety guards and panel covers are always firmly secured and not damaged.
- This appliance is not intended for use by young children or infirm persons unless they have been adequately supervised by a responsible person to ensure that they can use the appliance safely. Young children should be supervised to ensure that they do not play with the appliance.
- Installer must incorporate a means of electrical disconnection (isolator) in the sub mains fixed wiring in accordance with the latest edition of the AS/NZS 3000 (also known as Australian Wiring Rules).
- Secure the power cords and control cables that goes in/out the unit. Use the cable ties provided in the control box.
- This unit is fitted with Indoor EC Motors with high power capacitors, which can have dangerous voltages at terminals for up to 5 minutes after main power has been isolated. Wait at least 5 minutes after power isolation and test for high voltage before performing service work.
- EC Plug Fan fitted to this unit has dual power supplies, i.e. 400V/3Ph/50Hz motor power supply plus 10VDC control power supply. Care must be taken to ensure both are safely isolated to prevent personal injury and damage to the equipment.
- This unit is designed for use with R-410A refrigerant only.

\*Qualifications required will be appropriate Electrical, Refrigeration and Refrigerant Handling License and Training, dependent on local State/Territory regulations.

#### DANGER

##### **Hazardous Voltage - Risk of Electrocution.**

TURN-OFF the power from main isolator before proceeding with any service work of the unit. Observe proper LOCK-OUT/TAG-OUT (LOTO) procedures for electrical appliances in order to prevent accidental switching-on of the power supply.

#### WARNING

EC Motors are fitted with high power capacitors and can have dangerous residual voltages at motor terminals after power has been isolated. Wait at least 5 minutes after power isolation and test for any residual voltage before beginning service work.

#### CAUTION

##### **Beware of Rotating Fans!**

Ensure that indoor and outdoor fans are isolated and have come to a complete stand still before servicing the equipment. Beware of pinch point and sharp edges which can cause cutting injury. Secure the fans against accidental contact. Always wear appropriate PPE and remove any dangling jewellery and protect long hair by wearing a cap. Ensure that no loose clothing can be caught / entangled in moving parts.

#### **VISUAL INSPECTION and WORK ASSESSMENT**

Work areas and conditions must first be assessed and evaluated for any potential hazardous conditions. It is also important to be familiar with the unit parts and components before proceeding with any service task.

## 04. INSTALLATION INFORMATION

All service technicians handling refrigerant must be licensed to handle refrigerant gases.

### Recover and Recycle Refrigerants

Never release refrigerant to the atmosphere! It is an offence in Australia to do so. Always recover, recycle and reuse refrigerants. When removing from the system, properly contain and identify refrigerants in its dedicated container for proper disposal and/or storage. Always consider the recycle or reclaim requirements of the refrigerant before beginning the recovery procedures. Obtain a chemical analysis of the refrigerant if necessary. Refer recovered refrigerant and acceptable refrigerant quality to existing standards and regulations.

### Refrigerant Handling and Safety

Consult the refrigerant manufacturer's Material Safety Data Sheet (MSDS) for information on proper handling and to fully understand health, safety, storage and disposal requirements. Use the approved containment vessels and refer to appropriate safety standards. Comply with all applicable transportation standards when shipping refrigerant containers.

### Service Equipment and Recovery Procedures

Always use refrigerant reclaiming equipment in order to minimise refrigerant emissions. Use equipment and methods which will pull the lowest possible system vacuum while recovering and condensing refrigerant. Equipment capable of pulling a vacuum of less than 500 microns is required.

Do not open the system to the atmosphere for service work until refrigerant is fully removed and/or recovered. Perform refrigeration system evacuation, prior to charging, in accordance with AIRAH / IRHACE Refrigerant handling code of practice.

Let the unit stand for 1 hour and with the vacuum not rising above 500 microns. A rise above 500 microns indicates a leak from the system and a leak test is required to locate and repair any leak.

### CAUTION

A leak test is always required on any repaired section of the refrigeration system.

Charge refrigerant into the system only after the equipment does not leak or contain moisture. Ensure that R-410A is only charged in liquid form. Take into consideration the correct amount of refrigerant charge specified for the system to ensure efficient unit operations. When charging is complete, reclaim refrigerant from charging lines into an approved refrigerant container. Seal all used refrigerant containers with approved closure devices to prevent unused refrigerant from escaping to the atmosphere. Take extra care to maintain all service equipment directly supporting refrigerant service work such as gauges, hoses, vacuum pumps and recycling equipment.

**INSTALLATION PREPARATION (Pre-Installation considerations)**

The following items must be considered before beginning the unit installation:

- Verify the unit capacities and ratings with the unit nameplate
- Make certain the floor or foundation is level, solid and have sufficient structural strength to support the unit and accessories weight.
- Allow minimum recommended clearances for periodic maintenance and service access.
- Allow sufficient space above the unit for the outdoor air discharge. Condenser air inlet, located on the coil side of the unit, requires sufficient airflow clearance for the optimum unit performance.
- Note the conditioned supply air and return air location. Ensure sufficient spaces are allocated for these purposes.
- Refer connection and location of condensate drain in the unit drawing and dimensions section of this manual.
- Wiring connections must be in accordance with the wiring diagram provided with the unit.
- Make sure all wirings are in accordance with local electricity authority regulations and standards.
- Do not install the unit close to an area where there is a danger of fire due to volatile, explosive, flammable and/or hazardous materials.
- Ensure that spaces around the unit are free from any obstructions for optimum unit performance.
- Installer to ensure correct size/type that main circuit breaker and cable is installed in unit sub-mains to protect the sub-mains and unit wiring.
- Installer to ensure correctly rated residual current device (RCD) is installed as per with the latest edition of the AS/NZS 3000 (also known as Australian Wiring Rules).
- Secure the power cords and control cables that goes in/out the unit. Use the cable ties provided in the control box.

## **05. UNIT MOUNTING AND LOCATION**

1. The units must be installed in accordance with relevant authority regulations.
2. Install the unit on a level and strong foundation.
3. Install anti-vibration rubber or isolation mounts (installer to supply) under **all of the unit's feet** to help reduce noise and minimize vibration transfer through the foundation. Ensure that all anti-vibration rubbers are rated to provide stable support without impairing the unit's structural integrity.
4. Diameter or width of anti-vibration rubber's must be at least equal to the width of the actual feet to prevent deformation overtime.
5. Level the unit to ensure good condensate drainage away from the unit.
6. Ample service access areas and minimum space allowance for airflow must be provided.
7. Avoid installing the unit in such a place where there is danger of fire due to leakage of inflammable fluid.
8. Ensure that the spaces around the unit are free from any obstructions for optimum unit performance.

## 06. INSTALLATION INSTRUCTIONS

The installation instructions provided below are intended as a guide only and does not supersede the relevant council, state and federal codes, regulations and building code standards. Compliance and consultation with the authorities having jurisdiction with the installation of this equipment is the responsibility of the installer. ActronAir will not be held liable for any damages or costs as a result of the installer's failure to comply. Please refer to the matching outdoor unit Installation and Commissioning Guide for further information and details.

### Lifting The Unit

Adhere to WH&S regulations for safe and secure lifting practices in order to prevent physical injury.

Suggested lifting procedures are outlined in Section 09 as reference guide to safely lift and transport the unit, however, this does not over rule the industry WH&S practices.

### Location

Mount the unit in a stable and rigid support wherein the weight is properly distributed, such as roof joist and rafters. Take into consideration the minimum service access clearances provided in the unit drawings.

Locate the evaporator section away from the areas where noise is a critical factor. Use rubber mounting pad (not supplied) in order to minimize the transfer of noise and vibration into building structures.

#### NOTE

In locations where high humidity is expected, additional insulation shall be applied to the evaporator section.

### Condensate and Safety Tray Drainage

Suggested condensate and safety tray drainage instructions are provided at the proceeding page for your reference.

#### NOTE

The included safety tray is provided for collection of internal condensate and for back up in case of main drain blockage. In locations where high humidity is expected, additional insulation or safety tray may be required to provide protection for externally formed condensation.

### Supply Air and Return Air Duct

Supply and return air duct works must be adequately sized to meet the system's air flow and static pressure requirements. Refer to the unit drawing for supply air and return air duct dimensions, specific to your requirement.

In locations where high humidity is expected, ensure appropriate duct insulation level is considered for the environment. Inadequate insulation can result in condensate forming on the ductwork's surface, potentially leading to dripping condensation on the ceiling.

Ducted work should be adequately supported in order to prevent cold bridging.

#### NOTE

Fit a flex duct connection in between the unit and the duct system, where noise and vibration is a critical consideration.

### Return Air Filter

Air filters must be provided in the return air side of the unit to maintain the efficiency and prolong the operation of the unit. These are also paramount to satisfy requirement for a clean and hygienic room condition. Return Air filters must be placed in an easily accessible location for service and maintenance.

#### NOTES

- Return Air filters are not supplied with the unit as individual air filtration requirements vary.
- Ensure that filters are cleaned / replaced regularly.
- All exposed metal surfaces of the duct spigots should be adequately insulated when connecting ductwork to ensure performance and reduce the risk of condensation. All air gaps shall be appropriately sealed.

### Field Pipe Connections

Specifications and installation requirements for field pipe connections are contained in the Installation and Commissioning Guide of the outdoor unit that matches your evaporator section. Please refer to this guide and thoroughly understand the procedures for safe and correct indoor and outdoor connection.

### Field Electrical Connection

The power supply and control communication data to the evaporator sections are supplied via the outdoor unit. Please refer to the wiring diagram supplied with the outdoor unit for specifications.

All electrical work must be performed by a licensed electrician and must conform with the wiring diagram and all relevant electrical authorities.

## 07. COMPONENTS OVERVIEW

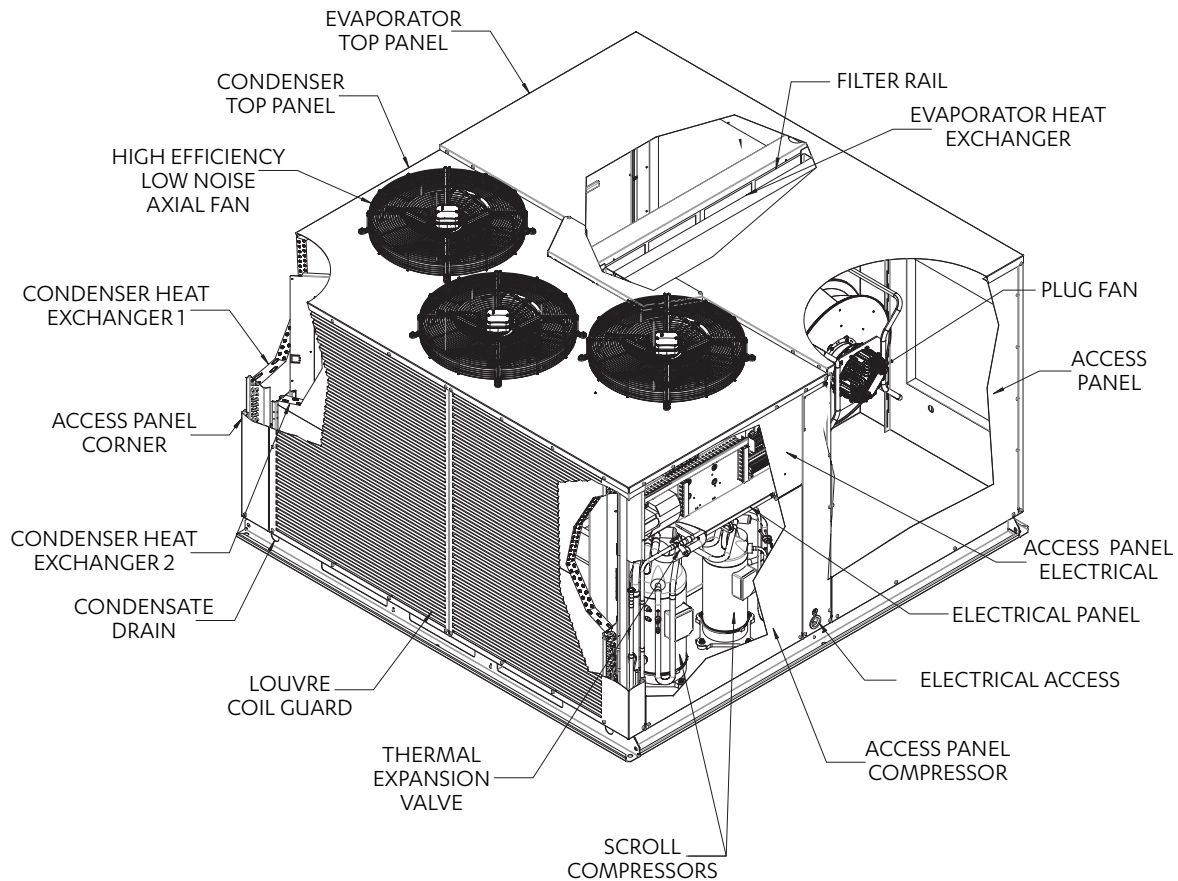

## 08. UNIT DIMENSIONS

### 08.01. PKY500T

DIMENSION (H x W x D) = 1465 x 2305 x 2365  
 SUPPLY DUCT (H x W) = 650 x 580  
 RETURN DUCT (H x W) = 900 x 700

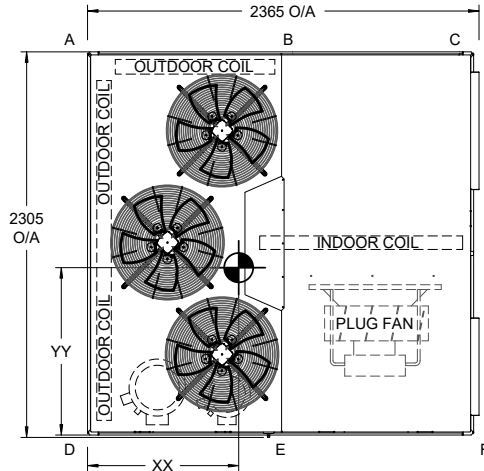
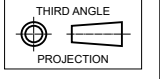

TOP VIEW

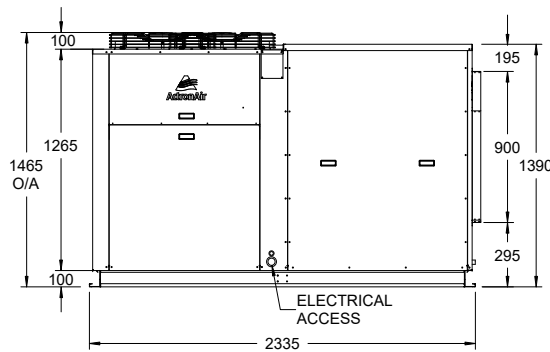
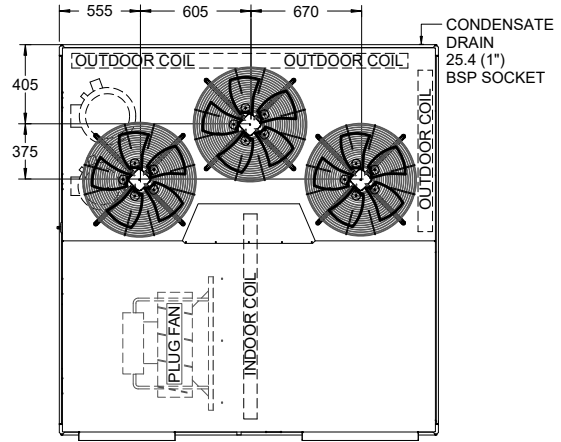

SIDE VIEW

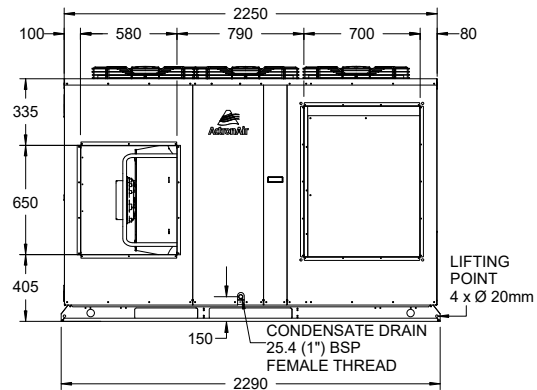

FRONT VIEW

Unit Air Handling Configuration (LH/RH)	Unit Weight	Corner Weights (kg)						Centre Of Gravity Position	
		A	B	C	D	E	F	XX	YY
Left Handing	853	127	171	52	169	254	80	1115	1060
Right Handing	853	118	189	97	175	207	67		

**NOTES:**

- Do not scale drawing. All dimensions are in mm unless specified. Refer to corresponding unit dimensional drawing for mounting hole details.
- LH/RH refers to Left Hand or Right Hand location of supply air.
- Ensure that Service Access Areas and Spaces for Airflow Clearances are met. This is based on the condition that the spaces around the units are free from any obstructions and a walkway passage of 1000 mm between the units or between the unit and the outside perimeter is available.
- Minimum service access areas and spaces for airflow clearances are responsibilities of the installer, ActronAir will not be held liable for any extra charges incurred due to lack of access and space for airflow.
- Under all circumstances, condenser air must not recirculate back onto condenser coil. Keep all clearance free of any obstructions.
- MTG C-C DIST = Mounting Centre to Centre Distance.
- Use M12 bolt for feet mounting.
- Diagrams are left handing.
- For reverse handling, service clearances for plug fan and airflow clearance for hood will be reversed. If the optional hood is not installed, 500mm clearance is required for service access. Airflow configuration shown is LH for illustration purposes only.

## 08.02. PKY620T

DIMENSION (H x W x D) = 1695 x 2305 x 2365  
 SUPPLY DUCT (H x W) = 650 x 580  
 RETURN DUCT (H x W) = 900 x 700

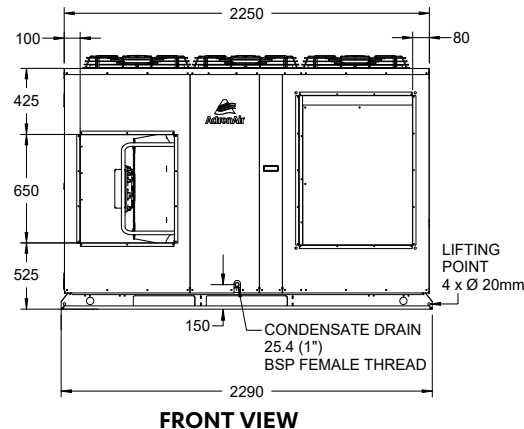
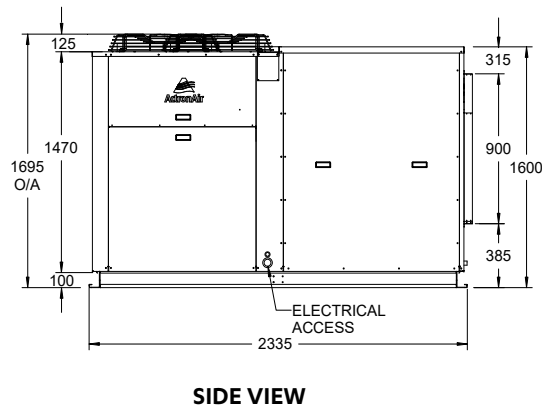
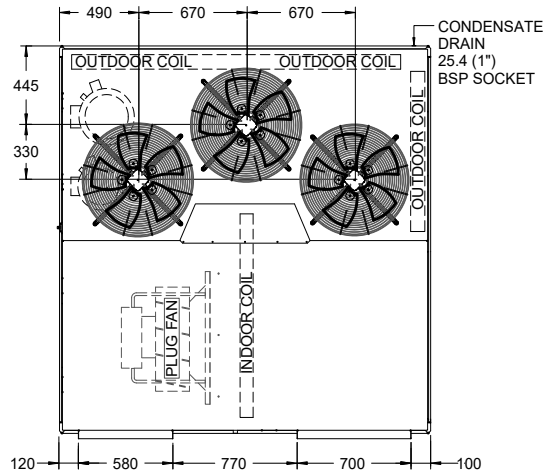
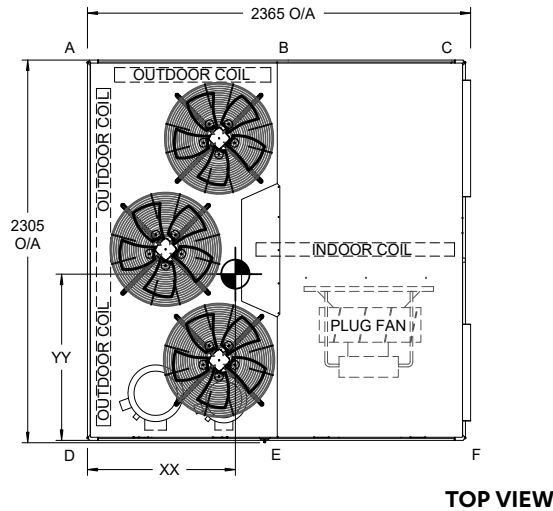
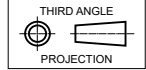

Unit Air Handling Configuration (LH/RH)	Unit Weight	Corner Weights (kg)						Centre Of Gravity Position	
		A	B	C	D	E	F	XX	YY
Left Handing	937	139	188	57	186	279	88	1115	1060
Right Handing	937	130	207	106	192	228	74		

**NOTES:**

- Do not scale drawing. All dimensions are in mm unless specified. Refer to corresponding unit dimensional drawing for mounting hole details.
- LH/RH refers to Left Hand or Right Hand location of supply air.
- Ensure that Service Access Areas and Spaces for Airflow Clearances are met. This is based on the condition that the spaces around the units are free from any obstructions and a walkway passage of 1000 mm between the units or between the unit and the outside perimeter is available.
- Minimum service access areas and spaces for airflow clearances are responsibilities of the installer, ActronAir will not be held liable for any extra charges incurred due to lack of access and space for airflow.
- Under all circumstances, condenser air must not recirculate back onto condenser coil. Keep all clearance free of any obstructions.
- MTG C-C DIST = Mounting Centre to Centre Distance.
- Use M12 bolt for feet mounting.
- Diagrams are left handing.
- For reverse handling, service clearances for plug fan and airflow clearance for hood will be reversed. If the optional hood is not installed, 500mm clearance is required for service access. Airflow configuration shown is LH for illustration purposes only.



## 08.03. PKY700T

DIMENSION (H x W x D) = 1695 x 2305 x 2365  
 SUPPLY DUCT (H x W) = 650 x 580  
 RETURN DUCT (H x W) = 900 x 700

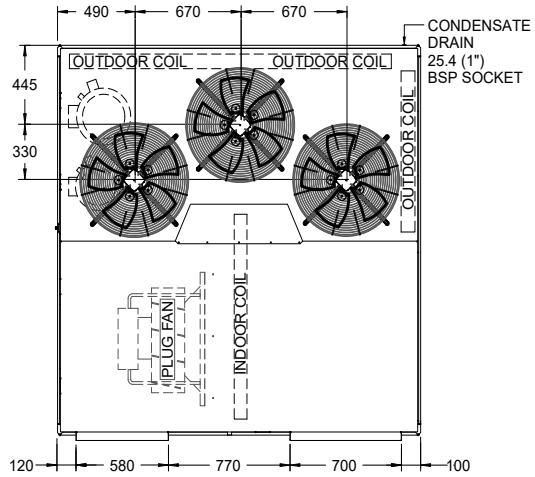
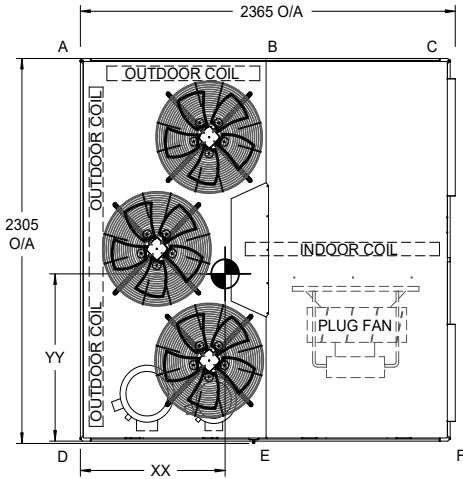
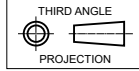

TOP VIEW

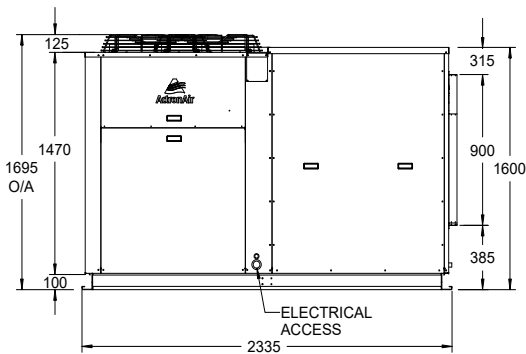

SIDE VIEW

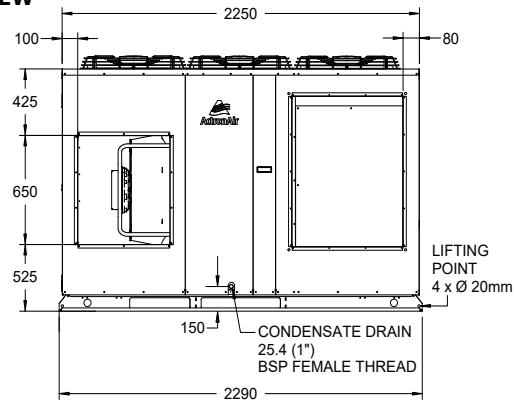

FRONT VIEW

Unit Air Handling Configuration (LH/RH)	Unit Weight	Corner Weights (kg)						Centre Of Gravity Position	
		A	B	C	D	E	F	XX	YY
Left Handing	964	143	194	59	191	287	90	1115	1060
Right Handing	964	134	213	110	197	234	76		

**NOTES:**

- Do not scale drawing. All dimensions are in mm unless specified. Refer to corresponding unit dimensional drawing for mounting hole details.
- LH/RH refers to Left Hand or Right Hand location of supply air.
- Ensure that Service Access Areas and Spaces for Airflow Clearances are met. This is based on the condition that the spaces around the units are free from any obstructions and a walkway passage of 1000 mm between the units or between the unit and the outside perimeter is available.
- Minimum service access areas and spaces for airflow clearances are responsibilities of the installer, ActronAir will not be held liable for any extra charges incurred due to lack of access and space for airflow.
- Under all circumstances, condenser air must not recirculate back onto condenser coil. Keep all clearance free of any obstructions.
- MTG C-C DIST = Mounting Centre to Centre Distance.
- Use M12 bolt for feet mounting.
- Diagrams are left handing.
- For reverse handling, service clearances for plug fan and airflow clearance for hood will be reversed. If the optional hood is not installed, 500mm clearance is required for service access. Airflow configuration shown is LH for illustration purposes only.

## 08.04. Base Mounting Details

PKY500T/PKY620T/PKY700T

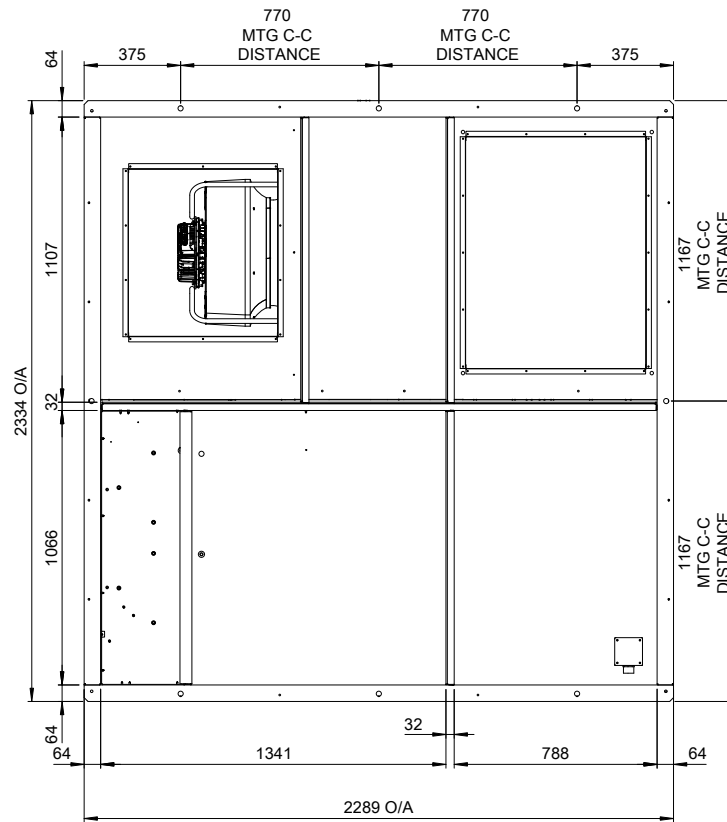

\*Diagram shown above is the base view from the bottom of the unit.

## 08.05. Service Access Areas and Airflow Clearances

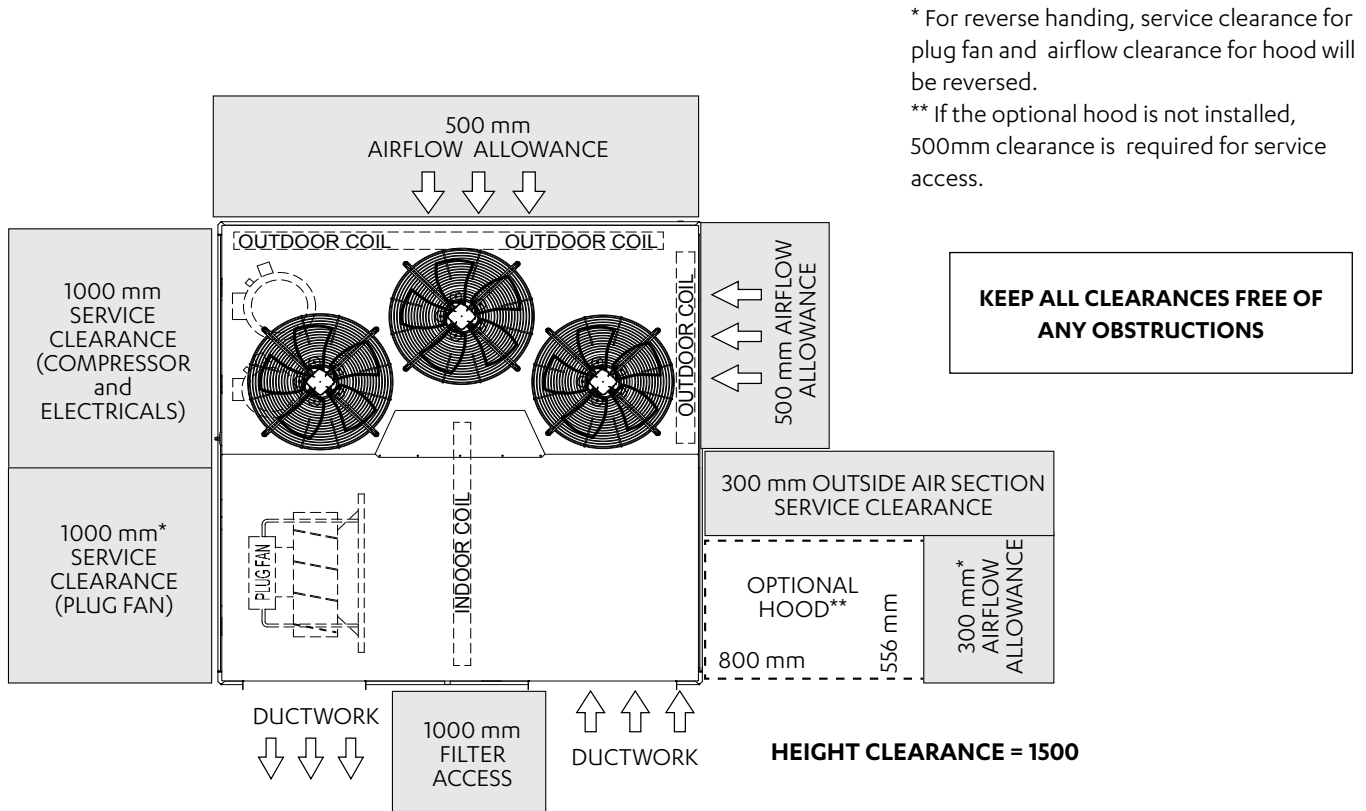

\* For reverse handling, service clearance for plug fan and airflow clearance for hood will be reversed.

\*\* If the optional hood is not installed, 500mm clearance is required for service access.

### NOTES:

1. Do not scale drawing. All dimensions are in mm unless specified. Refer to corresponding unit dimensional drawing for mounting hole details.
2. LH/RH refers to Left Hand or Right Hand location of supply air.
3. Ensure that Service Access Areas and Spaces for Airflow Clearances are met. This is based on the condition that the spaces around the units are free from any obstructions and a walkway passage of 1000 mm between the units or between the unit and the outside perimeter is available.
4. Minimum service access areas and spaces for airflow clearances are responsibilities of the installer, ActronAir will not be held liable for any extra charges incurred due to lack of access and space for airflow.
5. Under all circumstances, condenser air must not recirculate back onto condenser coil. Keep all clearance free of any obstructions.
6. MTG C-C DIST = Mounting Centre to Centre Distance.
7. Use M12 bolt for feet mounting.
8. Diagrams are left handing.
9. For reverse handling, service clearances for plug fan and airflow clearance for hood will be reversed. If the optional hood is not installed, 500mm clearance is required for service access. Airflow configuration shown is LH for illustration purposes only.

## 09. UNIT LIFTING PROCEDURES

### 09.01. Crane Lifting Method

#### NOTE

Crane lifting is recommended over fork lift method.

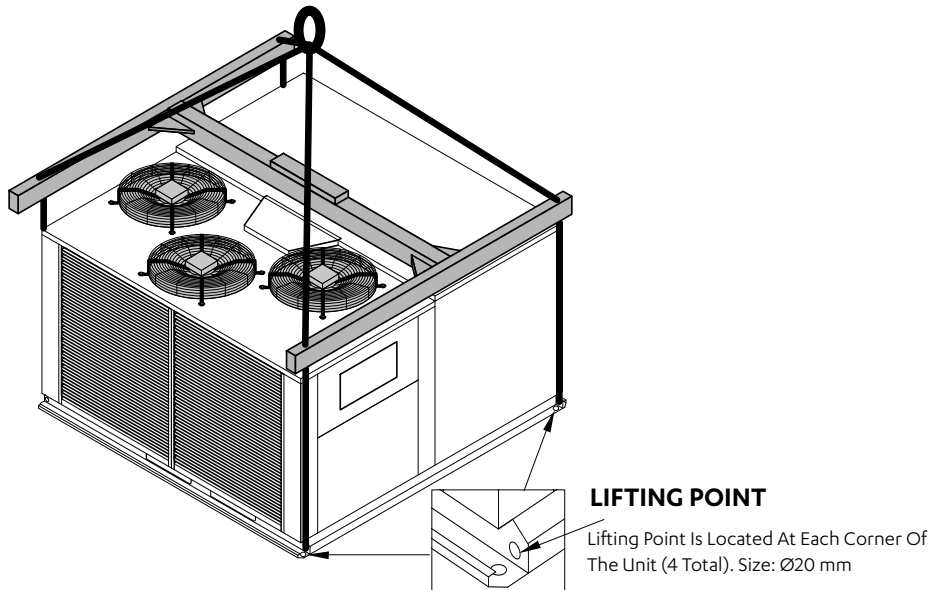

#### CAUTION

WH&S regulations must be observed and will take precedent during lifting process.

#### Equipment required for crane lifting:

- 4 x shackles
- 2 x nylon slings
- Spreader bar

#### NOTE

Refer to catalogue for unit weight before selecting shackles.

#### Procedure:

1. Remove all screws and washers that secure the unit to the timber pallet.
2. Use 4 x Bow or Dee shackles to connect the lifting holes.
3. Slip nylon slings through all shackles.
4. Ensure slings are protected by rubber pads or similar, if slings are draped across unit edges and corners. This will prevent the unit from being damaged during lifting.
5. SPREADER BAR must be used when lifting the unit.

## 09.02. Fork Lift Method

### Procedure:

1. To move the unit around with the pallet, it is required to insert the fork through the pallet (not the unit feet).
2. Only fork the unit through compressor end (see illustration for location of compressor end).

### NOTES

- Ensure that the screws and washers are only removed when it is required to disassemble the unit from the pallet.
- The length of the fork lift tines need to be at least 1365 mm in length in order to carry the unit.
- Before lifting the unit, ensure the tines go past the center line of the unit.

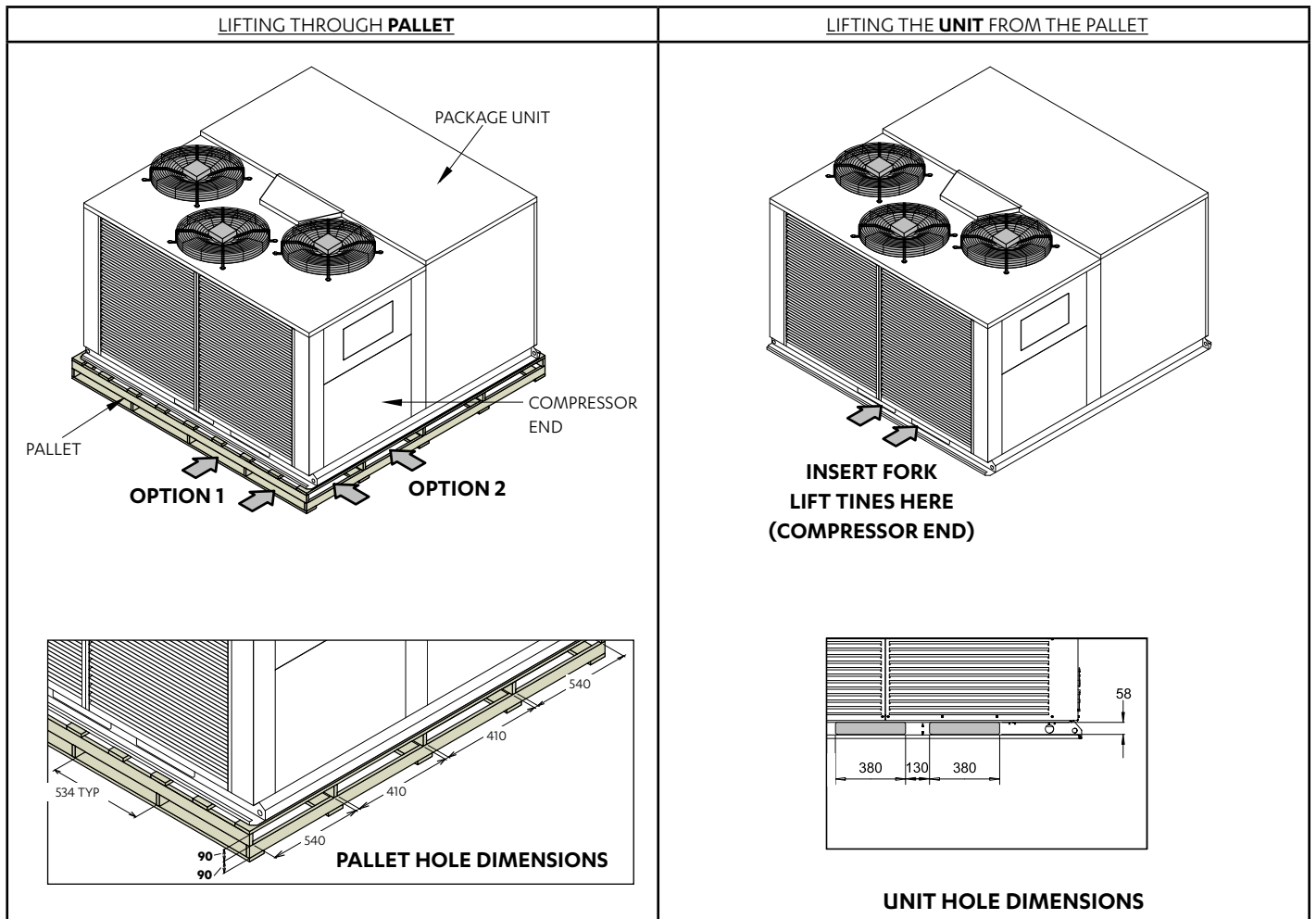

ALL DIMENSIONS ARE IN MM.

## 10. CONDENSATE DRAINAGE INSTRUCTIONS

### 10.01. Suggested Minimum Slope to Ensure Correct Drainage

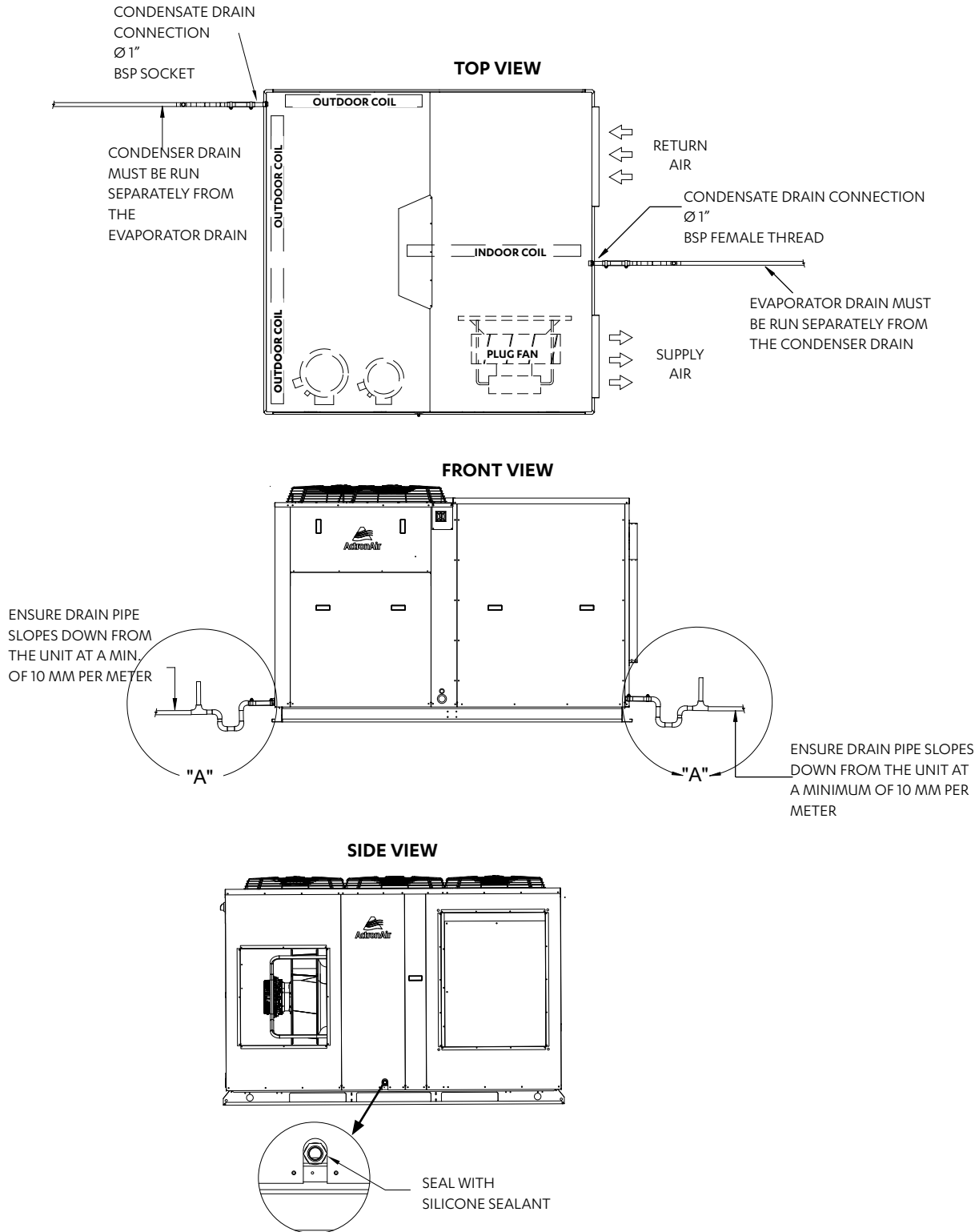

## 10.02. Suggested Drain Trap Details

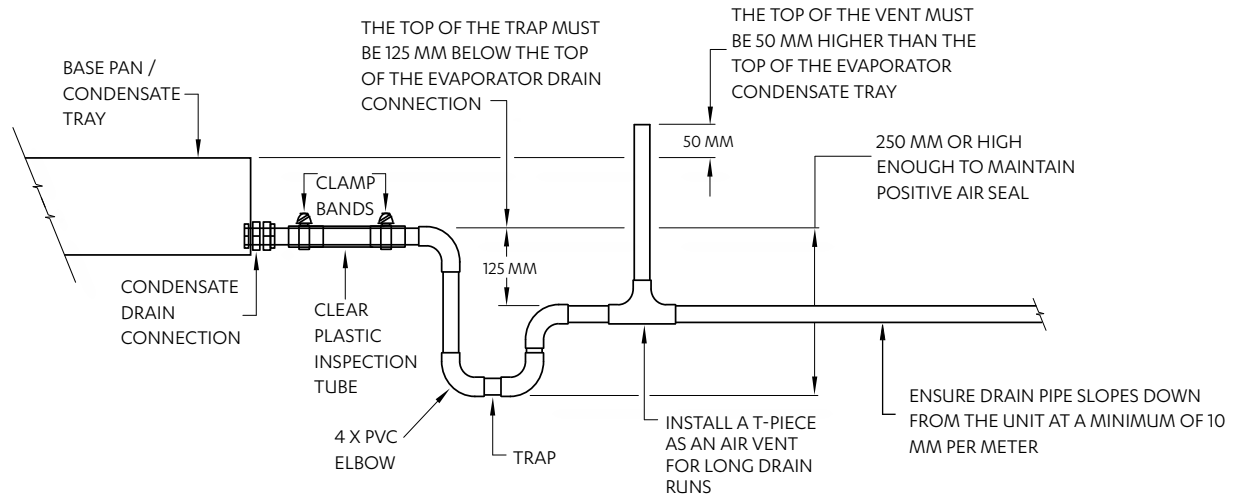

**DETAIL A**

### NOTES

- Parts for the Condensate Trap are not supplied with the unit.
- Refer to Unit Dimensions page of the Technical Selection Catalogue for specifications of drain connectors.

## 11. BANKING OF UNITS

### NOTES

- The suggested Clearance and Airflow Allowances (given above) are the minimum and based on the condition that the spaces around the units are free from any obstructions and walkway passage of 1000 mm between the units or between the unit and the outside perimeter is available.
- Minimum service access areas and spaces for airflow are responsibilities of the installer, ActronAir will not be held responsible for any extra charges incurred due to lack of access and space for airflow.
- Do not scale drawing.

### 11.01. End-To-End Configuration

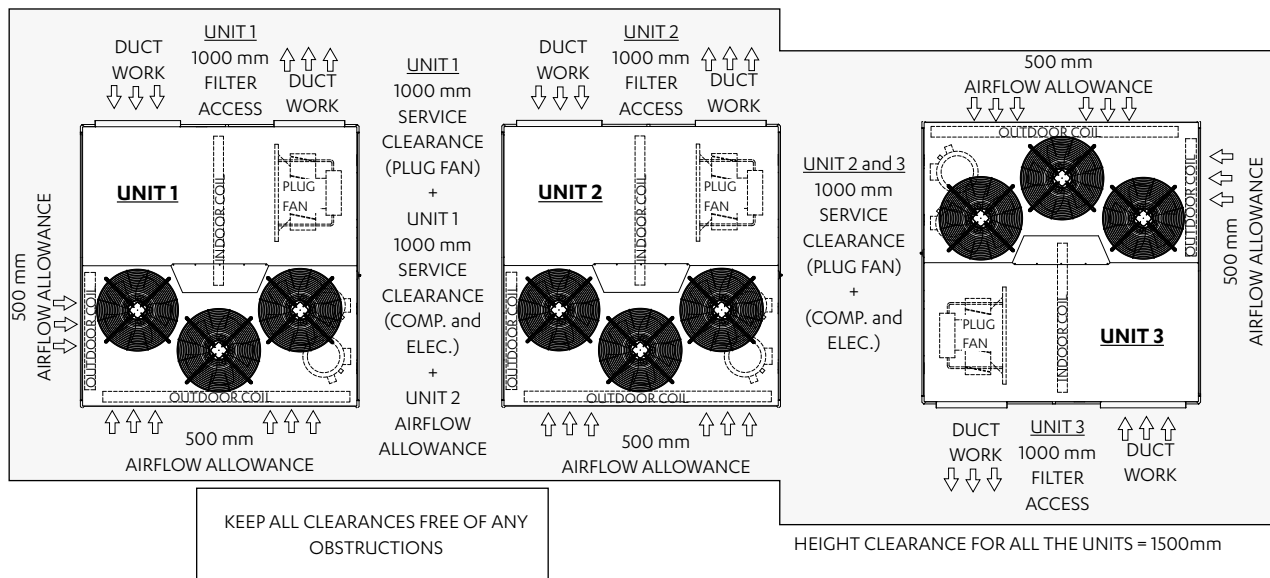

### 11.02. Cluster Configuration

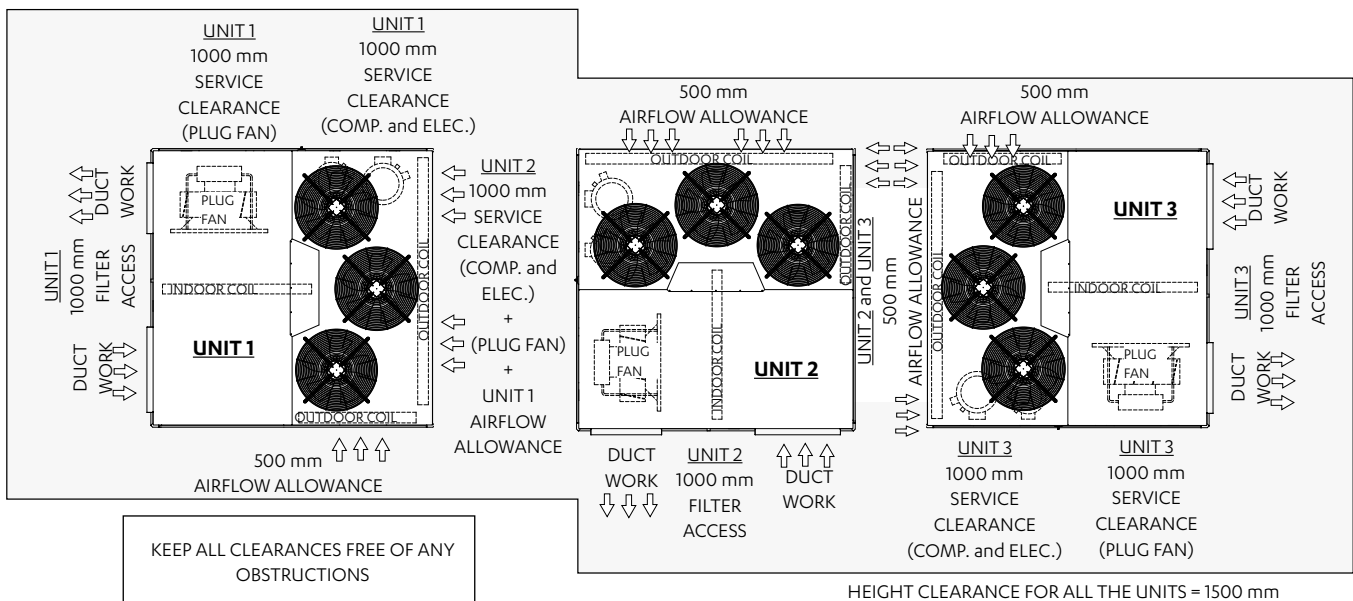





## 11.05. Standard Model

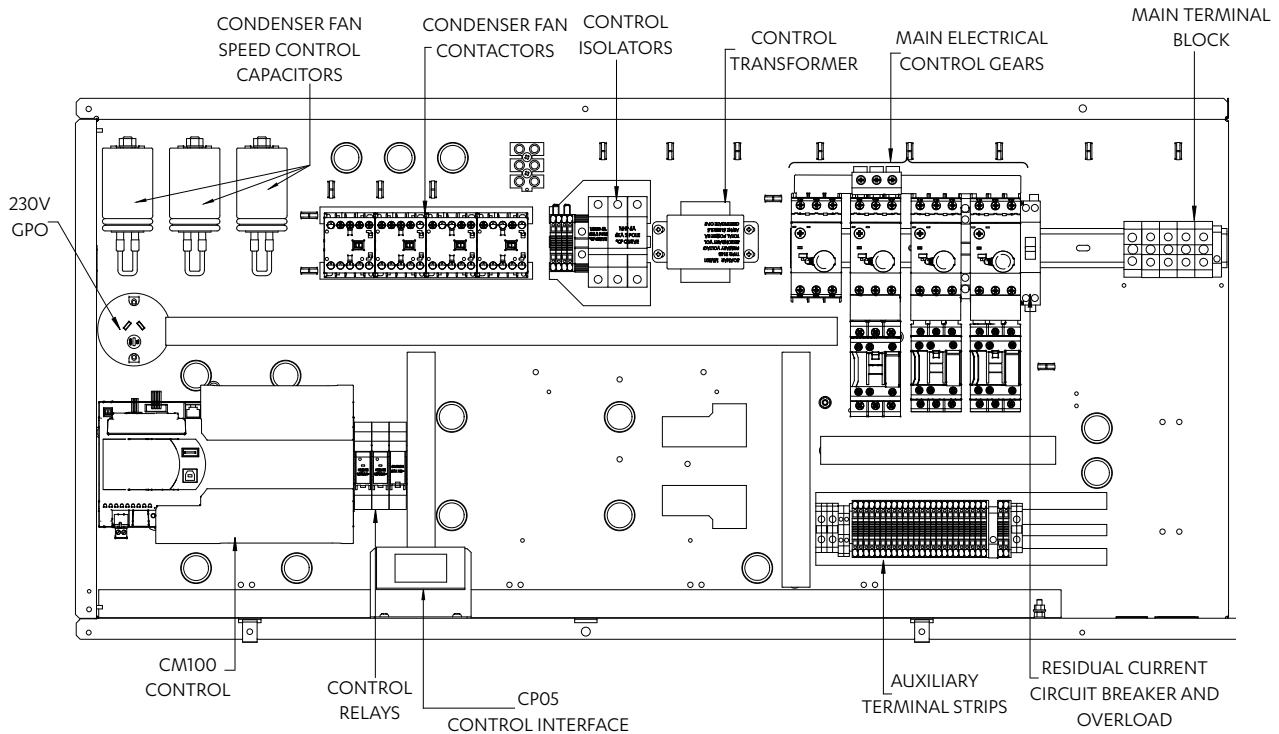

## 11.06. Standard Model with Optional 3-Phase Protection Relay

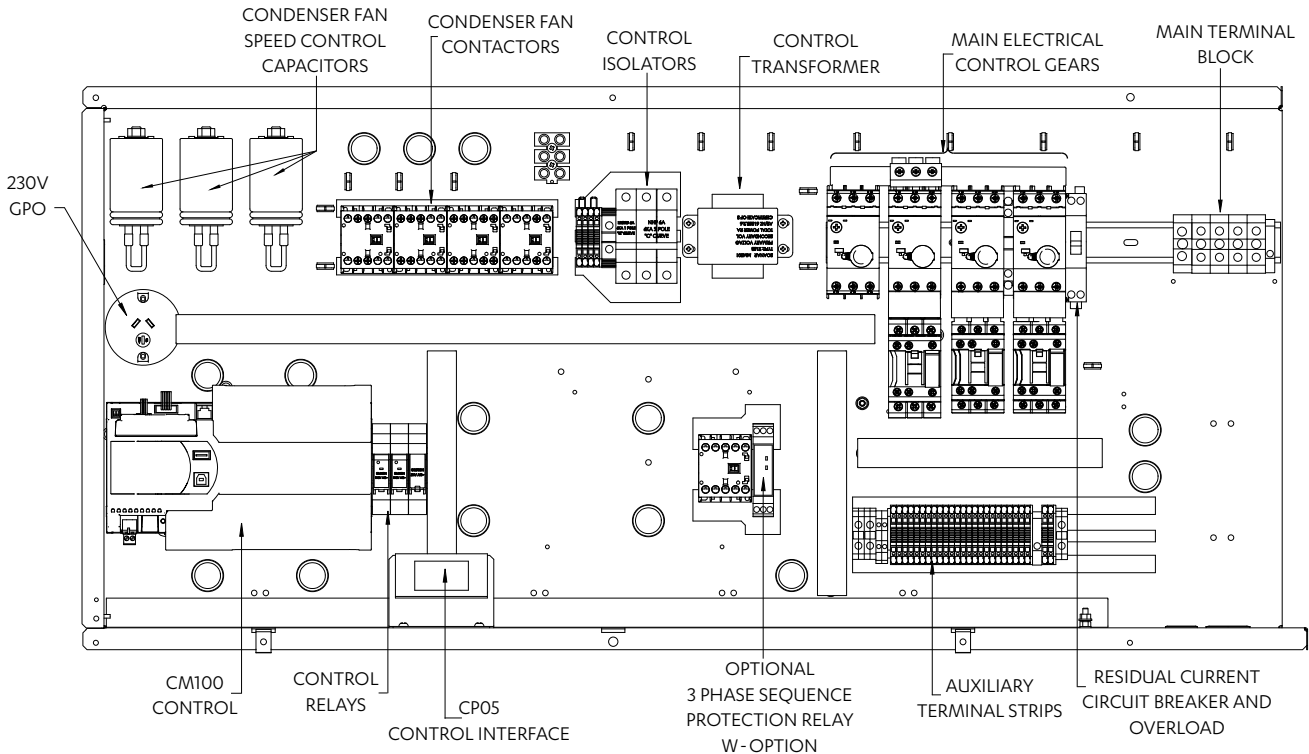

## 11.07. Standard Model with Optional 3-Phase Soft Starters

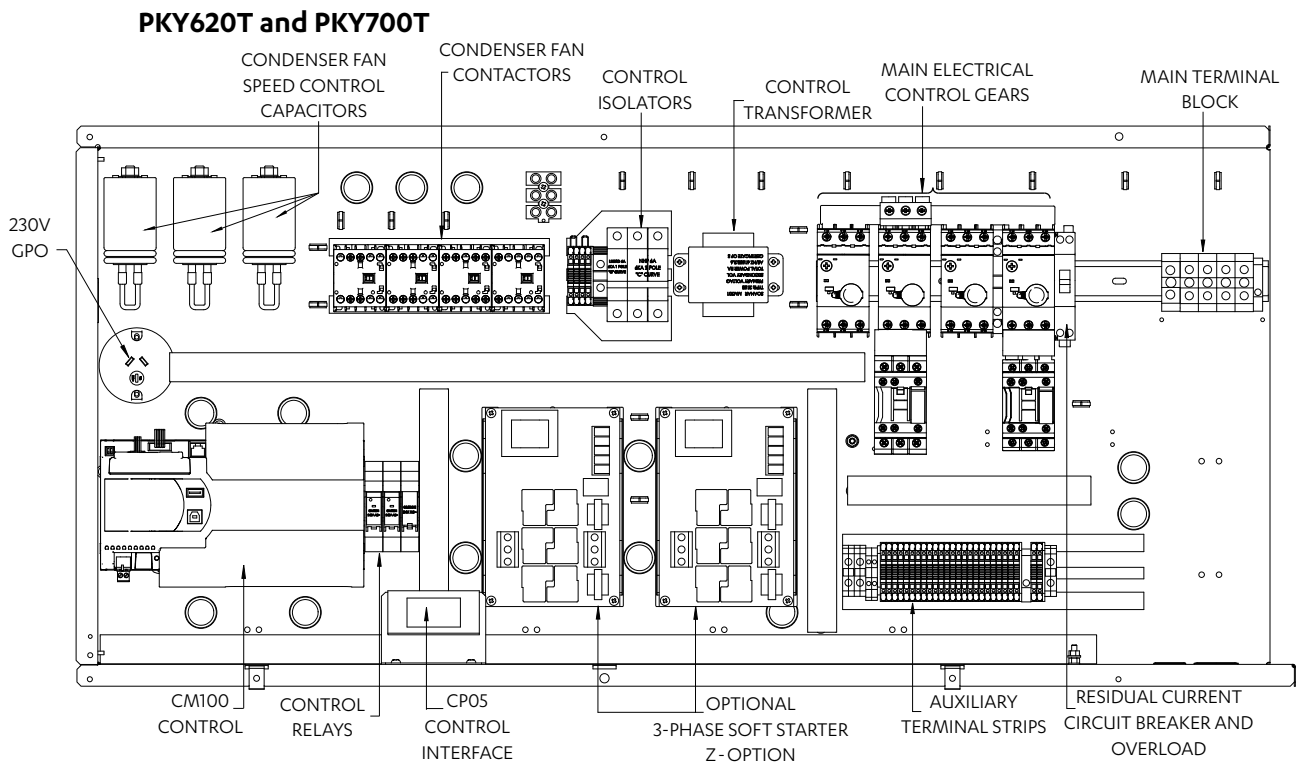
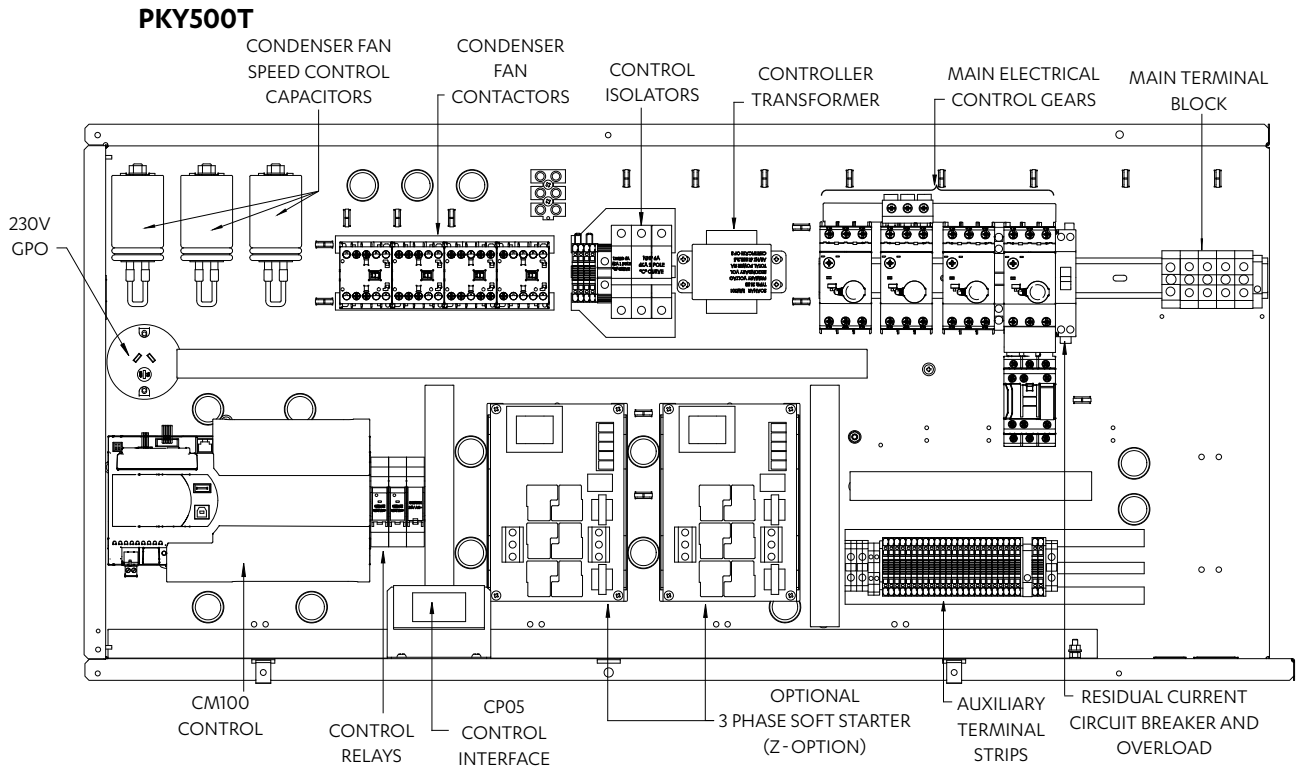

## 11.08. With Optional EC Outdoor Fans

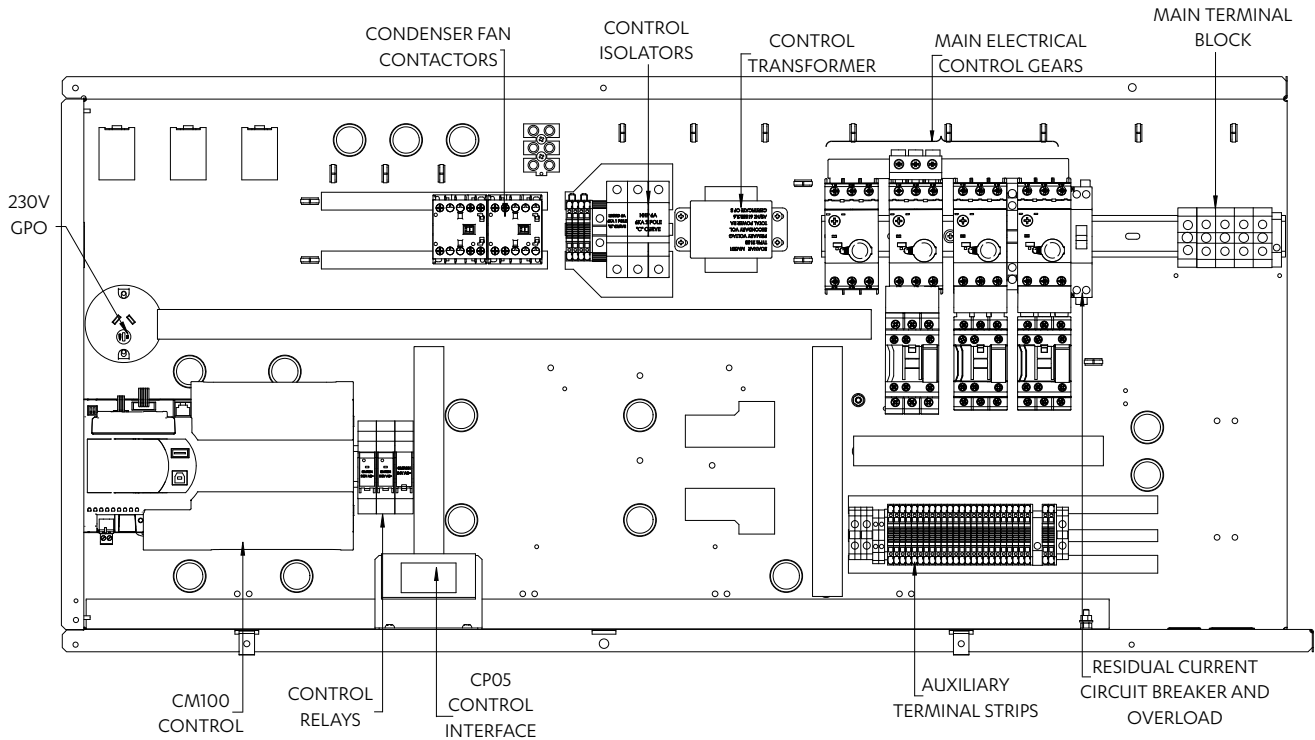

## 11.09. With Optional EC Outdoor Fans and 3-Phase Protection Relay

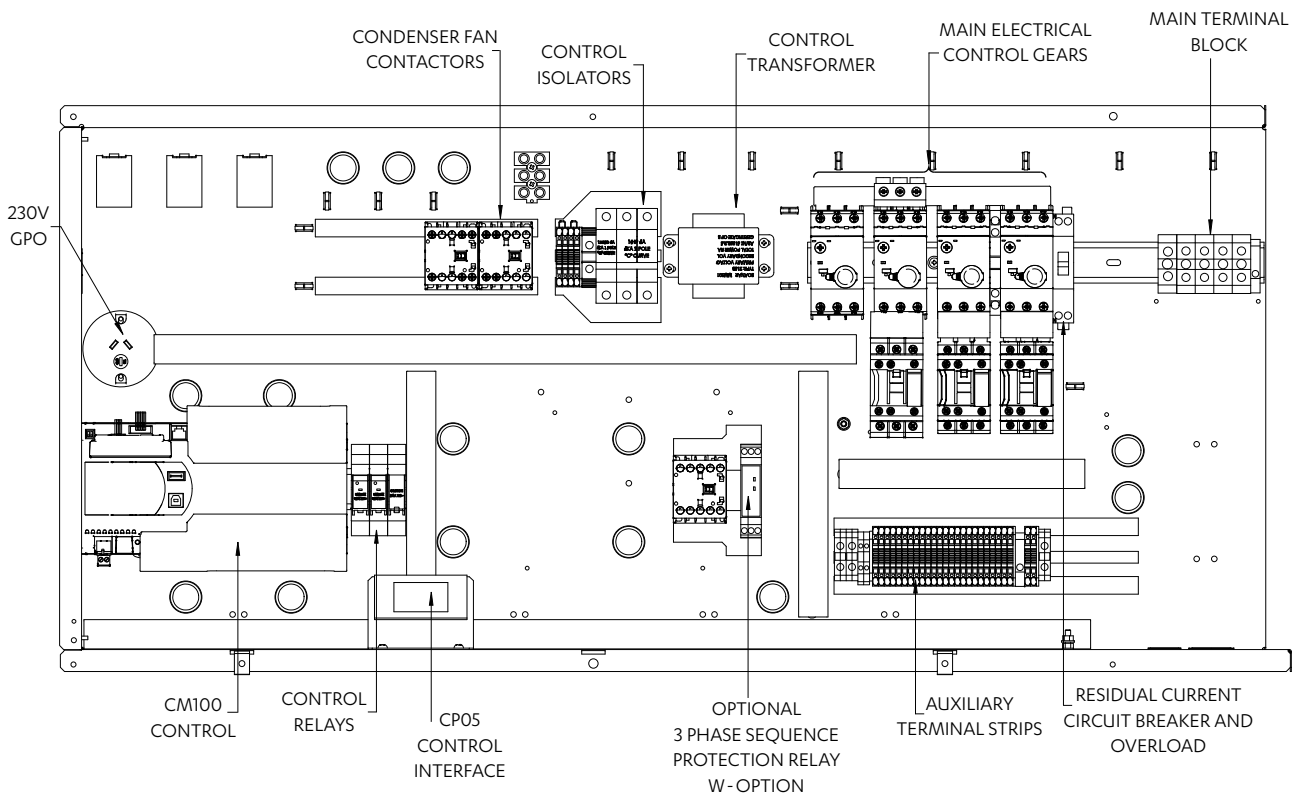

## 11.10. With Optional EC Outdoor Fans and 3-Phase Soft Starters

### PKY500T

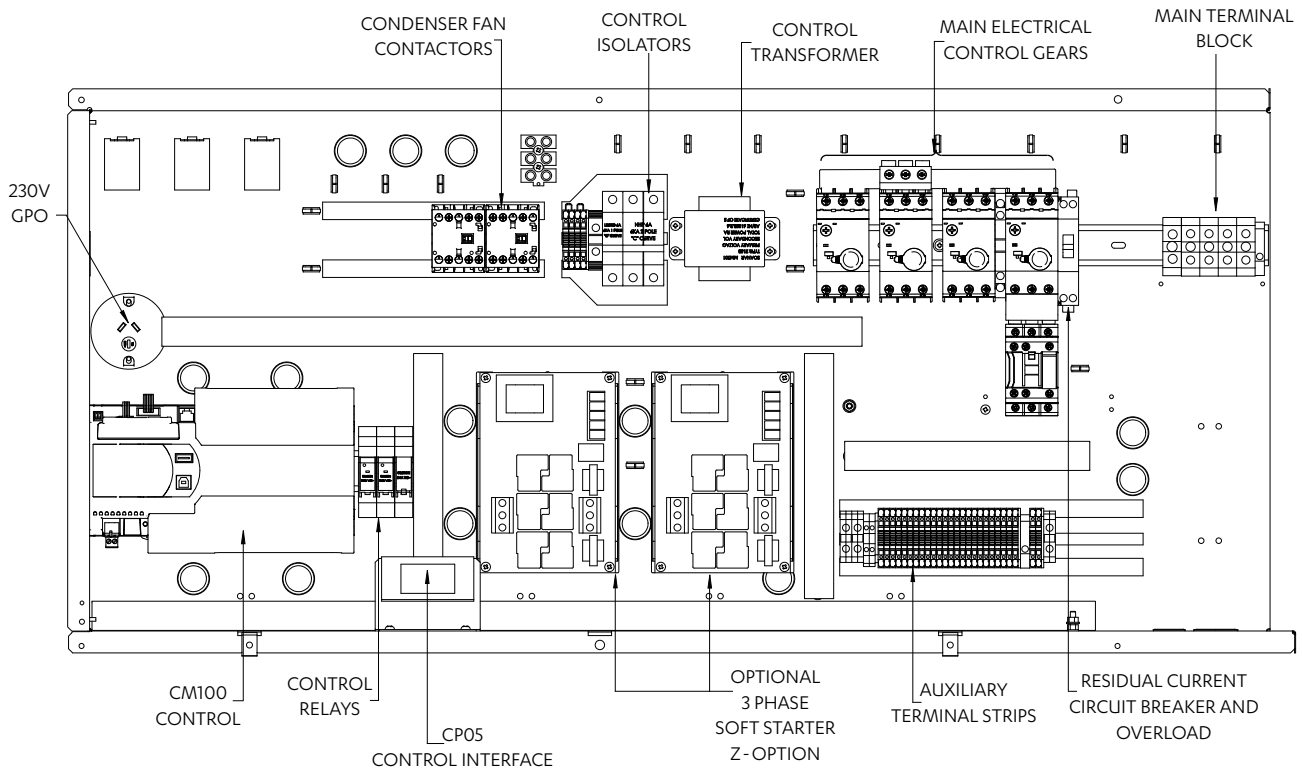

### PKY620T and PKY700T

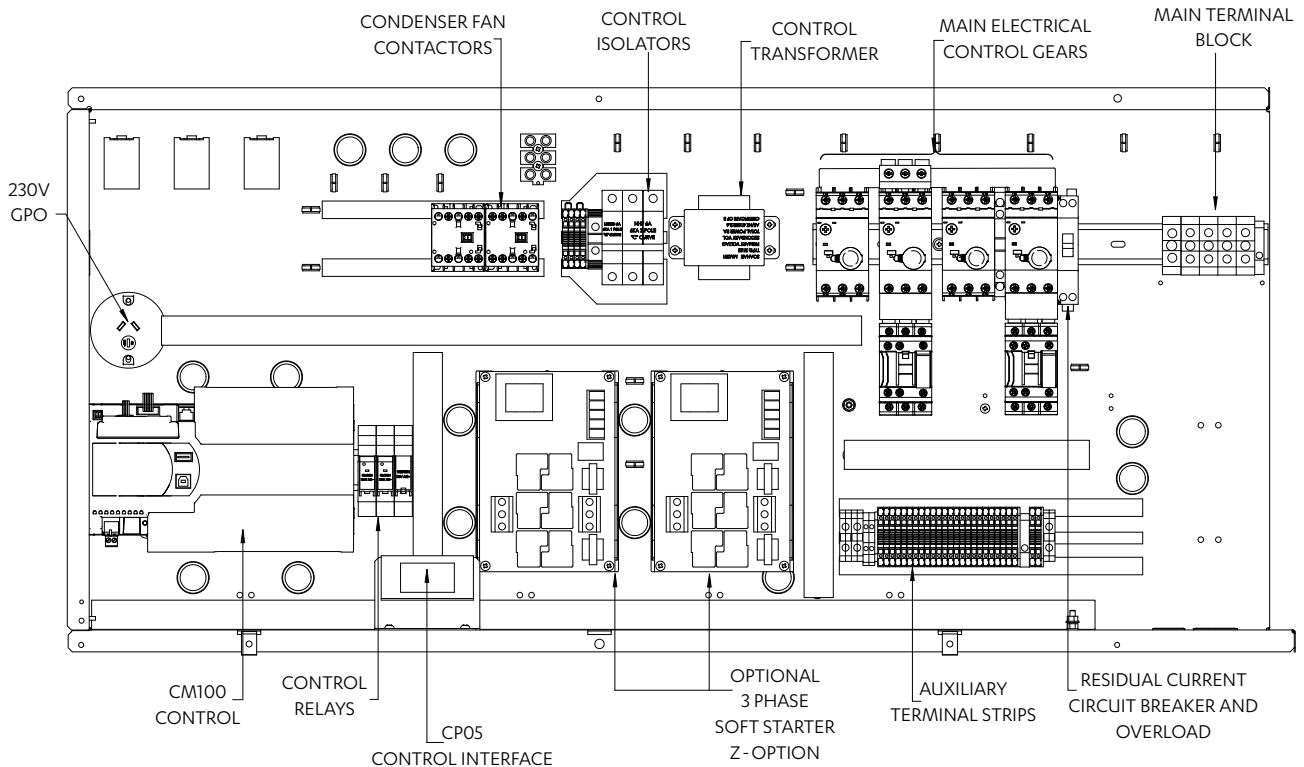

## 12. UNIT PREPARATION

### 12.01. Supply and Return Angle Plate Installation

Supply Angle Assembly

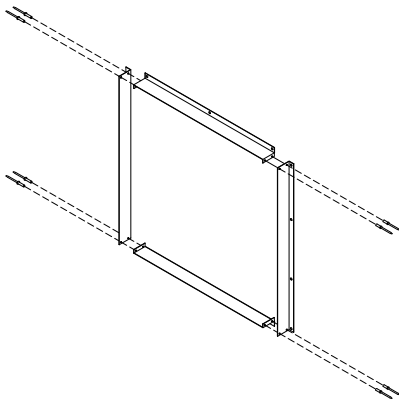

1. Assemble supply angle short plate and supply angle long plate using the provided rivet as shown above.

Materials:

- supply angle short plate x 2 pieces.
- supply angle long plate x 2 pieces.
- rivet x 8 pieces.

2. Attach the supply angle assembly onto supply air opening using provided screws as shown below.

Material:

- stainless steel screw 12G x 5/8 x 14 pieces.

Return Angle Assembly

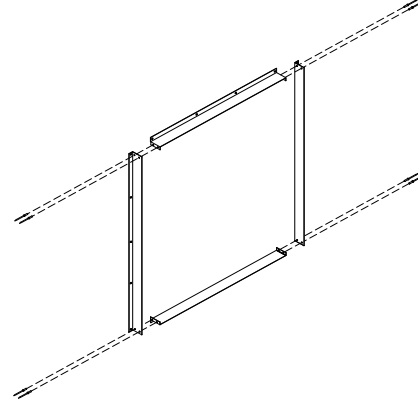

3. Assemble return angle short plate and return angle long plate using the provided rivet as shown above.

Materials:

- return angle short plate x 2 pieces.
- return angle long plate x 2 pieces.
- rivet x 8 pieces.

4. Attach the return angle assembly onto supply air opening using provided screws as shown below.

Material:

- stainless steel screw 12G x 5/8 x 18 pieces.

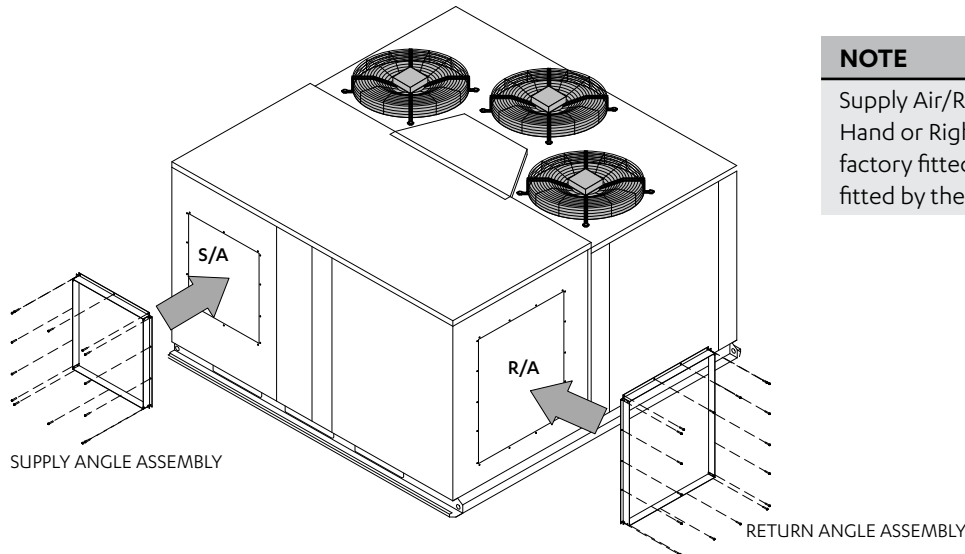

#### NOTE

Supply Air/Return Air angle with optional Left Hand or Right Hand side configuration are not factory fitted. These are to be field assembled and fitted by the installer.

#### NOTES

- All screws, rivets and supply return plates are supplied with the unit.
- All items are packed and located inside return air plenum (either beside indoor plug fan or on the filter rail).
- This assembly instruction is also applicable to the following unit options:
  - (a) supply air side, (b) supply air front, (c) return air side and (d) return air front.
- Tools required (not supplied): rivet gun and Phillips screw driver.

## 12.02. Supply and Return Angle Plate Assembly/Installation

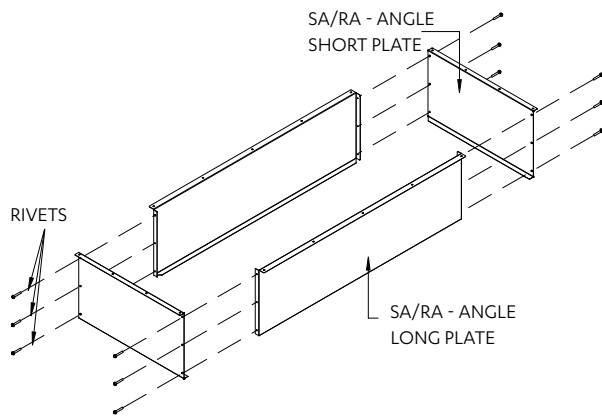

**1. Assemble supply air and return air angle plates using the provided rivet as shown in illustration on left.**

Materials:

- 2 Pieces - Supply Angle Short Plate
- 2 Pieces - Supply Angle Long Plate
- 2 Pieces - Return Angle Short Plate
- 2 Pieces - Return Angle Long Plate
- 24 Pieces - Rivets
- 32 Pieces - 10G x 1/2 Philip Pan Head Screws
- 1 Roll - PVC Closed Cell Tape

**2. Attach the supply angle assembly onto supply air opening by following detail - A procedures below.**

**3. Follow step 2 to attach the return angle assembly.**

### Unit Assembly

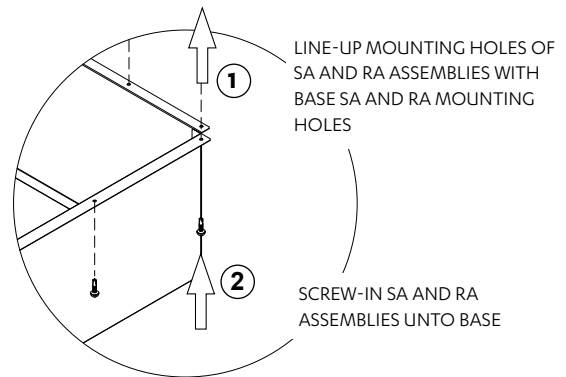
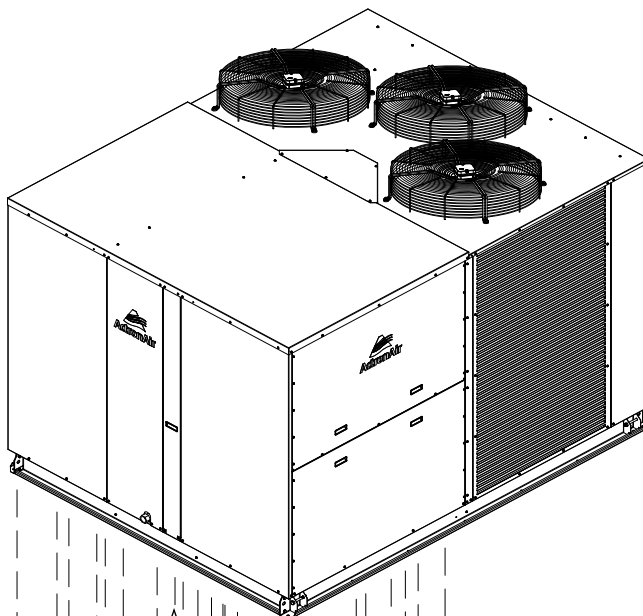

#### DETAIL A

Supply Air/Return Air Assembly Installation Details.

Supply Angle Assembly

Return Angle Assembly

### NOTES

- All bolts, rivets and supply and return plates are supplied with the unit.
- All items are packed and located inside return air plenum (either beside indoor plug fan or on the filter rail)
- Apply PVC closed cell tape (supplied) to adjoining contact edges before fastening bolts to ensure tight air seal.
- Tools required (not supplied): rivet gun and socket wrench.

### NOTE

Bottom Supply Air/Return Air angle options are not factory fitted. These are to be field assembled and fitted by the installer.

## 12.03. Electrical Mains and Isolator Installation

Removal Order:  
 (A) Pull-Out  
 (B) Pull-Down to remove Electrical Panel

**1. Remove Electrical Panel**

- Remove mounting screws (4 pieces).
- Remove Access Panel - Electrical as shown in the above illustration

**2. Remove Electrical Panel - Compressor**

- Remove mounting screws (4 pieces).
- Remove Electrical Panel - Compressor as shown in the above illustration.

Secure the cables firmly using the cables ties and clamp provided in the panels

Main Terminal Block				
E	L1	L2	L3	N
Earth	Line 1	Line 2	Line 3	Neutral

**MAIN LINE**

**3. Connect electrical and control wirings**

- Route electrical mains cable, indoor cable connections and wall control wires as shown above.
- Refer to electrical section for electrical and control connections.



## 12.04. Compressor Shipping Blocks Removal

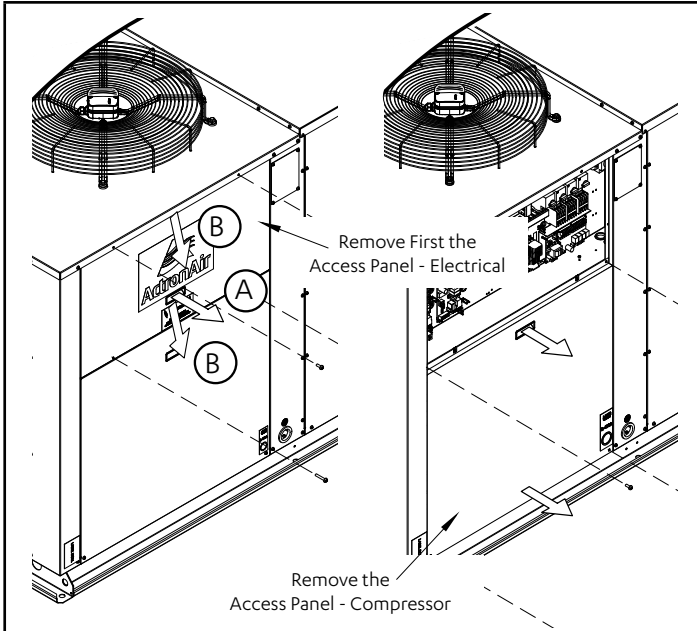

### 1. Remove Access Panel - Compressor

- Remove the Access Panel - Compressor by following the Access Panels removal procedure from previous page.

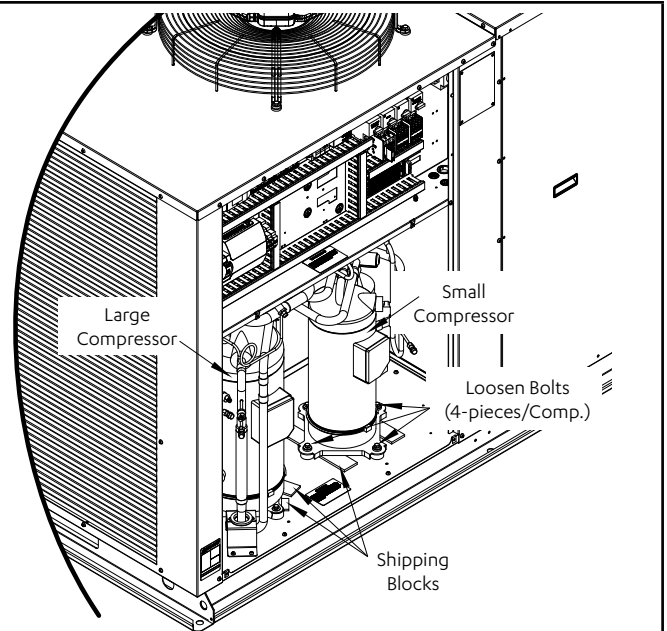

### 2. Loosen the Bolts - Compressor Mounting

- Loosen the bolts that hold the compressors down onto the unit (4 pieces each).

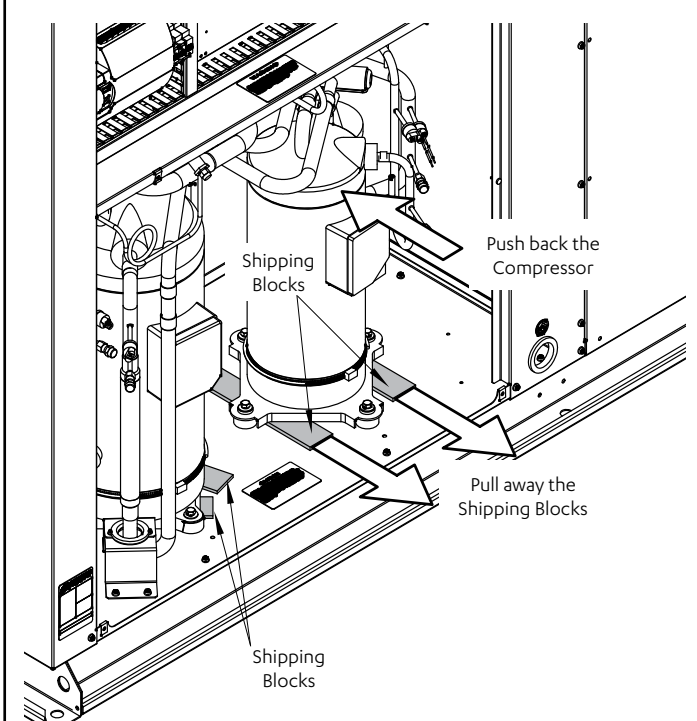

### 3. Remove the Shipping Blocks

- Push the Compressor back, taking care not to exert too much force that may cause damage to the pipes.
- Remove the Shipping Blocks by pulling them away.
- Repeat the same procedure for the 2nd compressor.

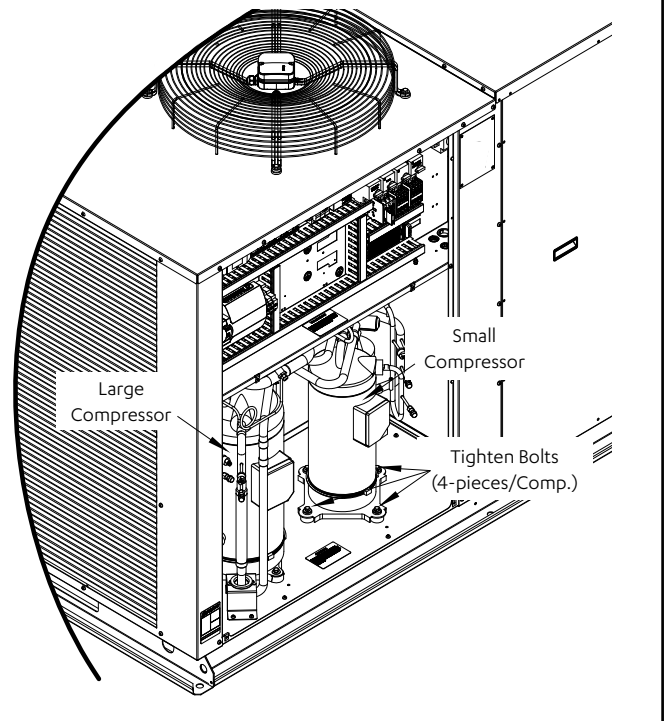

### 4. Tighten back the Bolts

- Firmly tighten the bolts to secure back the compressors onto the unit. Recommended torque is  $13 \pm 1$  Nm. It is critically important for the grommet not to be compressed.
- Check to make sure that there are no damage to the piping systems.

## 12.05. Air Filter Installation

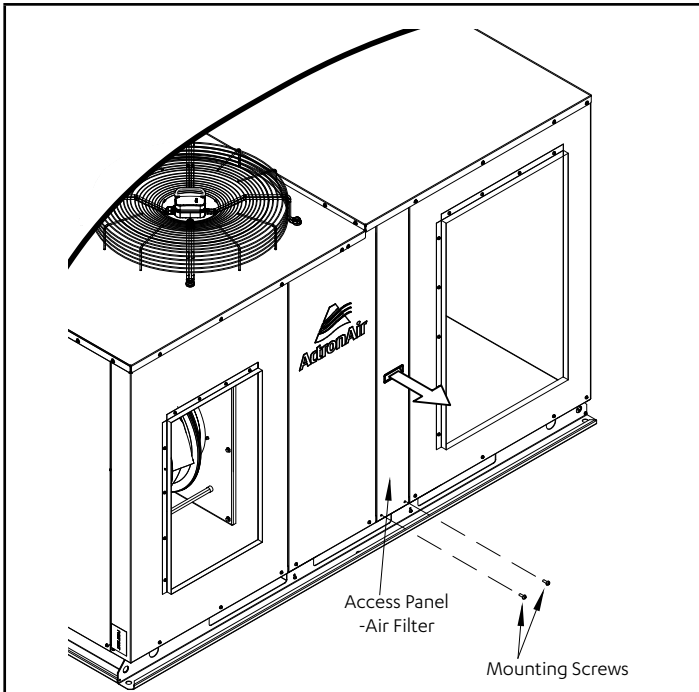

### 1. Remove Access Panel - Air Filter

- Remove mounting screws (2 pieces).
- Remove Access Panel - Air Filter as shown in the above illustration

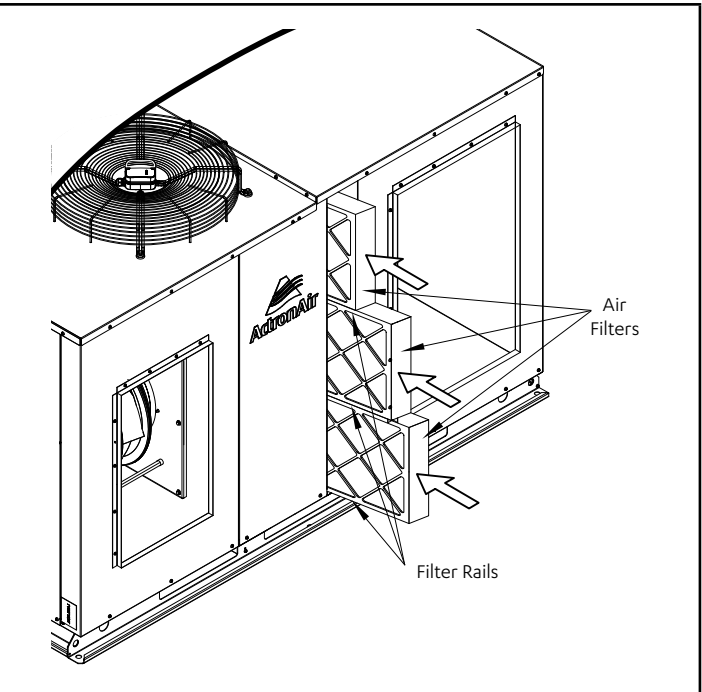

### 2. Install Air Filters

- Install Air Filters (6 pieces required) by sliding the filters one at a time in the provided Filter Rails.
- See notes and specifications below.

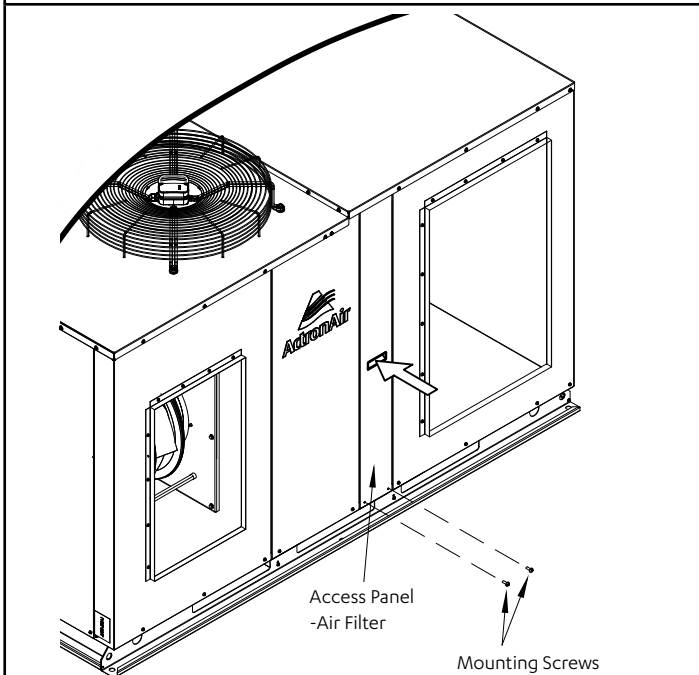

### 3. Replace Access Panel - Air Filter

- Replace Access Panel - Air Filter as shown above.
- Replace mounting screws, clean and tidy up the air conditioning unit.

### NOTES

- Air Filters are not supplied with the unit.
- Adequate Air Filters must be supplied and fitted by the Installing Contractor.

### AIR FILTER SPECIFICATIONS<sup>w</sup>

Models	Qty	Air Filter Sizes (H x W x T - mm)
PKY500T	6	404 X 621 X 100
PKY620T-700T	4	508 x 621 x 100
	2	408 x 621 x 100

### 13. ELECTRICAL

**NOTES**

- All electrical work must be carried out by a qualified technician.
- Make sure all wiring is in accordance with local wiring rules.
- Wiring connections should be made in accordance with the provided wiring diagram.
- The unit wiring diagram is located in the Access Panel - Electrical.

**13.01. Package Electrical Connection**

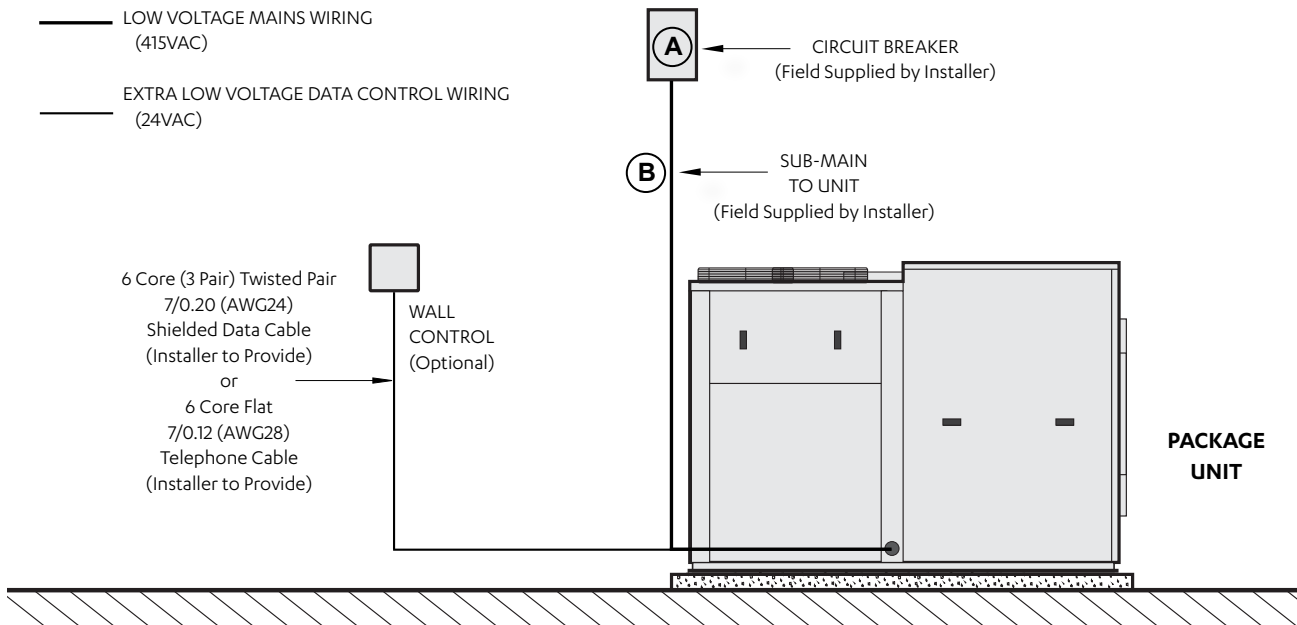

POWER CIRCUIT BREAKER SIZE and CABLE SIZE		
Model	Circuit Breaker Size (A)	Cable Size * MAIN (4 Core +E) (B)
	Amps	mm <sup>2</sup>
PKY500T	50.0	10.0
PKY620T	63.0	16.0
PKY700T	80.0	25.0

\* Suggested Minimum Cable Size should be used as a guide only, refer to AS/NZS 3000 "Australian / New Zealand Wiring Rules" for more details.

WIRING DIAGRAM MATRIX	
Model	Wiring Diagram
PKY500T	0515-8206
PKY620T	0515-8606
PKY700T	0515-8606

## 13.02. Maximum Cable Lengths

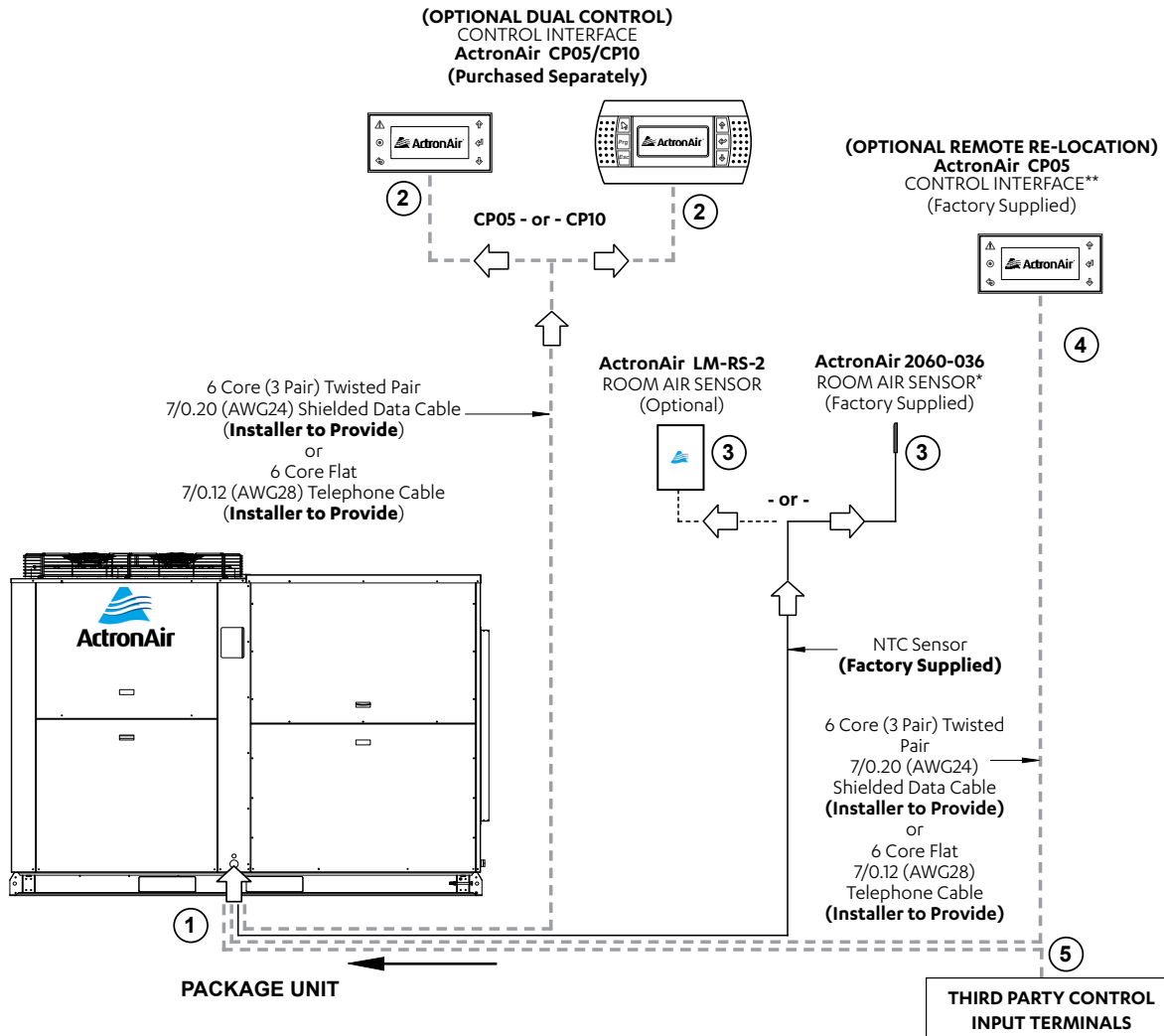

Cable Run	Description	Suggested Maximum Cable Length
1 to 2	Outdoor CM100 to Optional ActronAir CP05/CP10 Control Interface (Dual Control)	50m/200m***
1 to 3	Outdoor CM100 to Return Air Sensor (NTC Sensor Input Cable Size 0.5mm <sup>2</sup> / 1.0mm <sup>2</sup> )	50m/100m
1 to 4	Outdoor CM100 to ActronAir CP05 (Remotely re-located Factory Supplied Control Interface)	50m / 200m***
1 to 5	Outdoor CM100 to Third Party Control	Refer to Third Party Control Supplier

### NOTES

- Diagram shown above is for general representation only. Refer to individual unit wiring diagram for complete wiring connection details.
- Long cable runs beside supply mains or TV antenna cables should be avoided where possible.
- Room Air Sensor needs to be installed by the installer specific to site requirements.
- Suggested Maximum Cable Length: 50m when using Flat Telephone Cable/200m when using 6 Core (3 Pair) Twisted Pair Shielded Data cable.
- For compliance with EMC requirements, connect screen wire to Terminal 22 on the Outdoor Panel.

\* Room Air Sensor is factory supplied with 6m cable as standard. Sensor may need adjustment for longer cable lengths.

\*\* Do not extend the factory supplied data cable when re-locating the Control Interface. Replace the cable with a single length of either of the data cables specified above.

\*\*\* Suggested Maximum Cable Length: 50m when using Flat Telephone Cable/200 m when using 6 Core (3 Pair) Twisted Pair Shielded Data cable.



## 13.04. Return Air - Outside Air - Spill Air Control Wiring Procedures

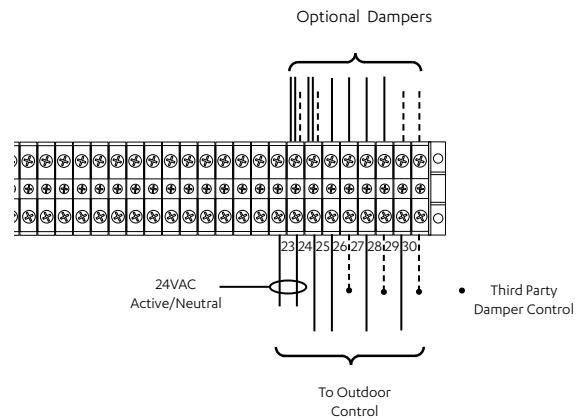
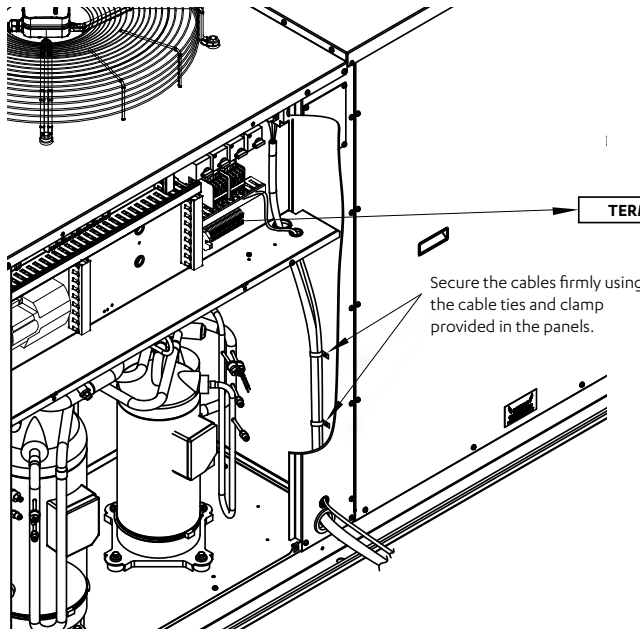

Refer to diagram below for details of DAMPER connections.

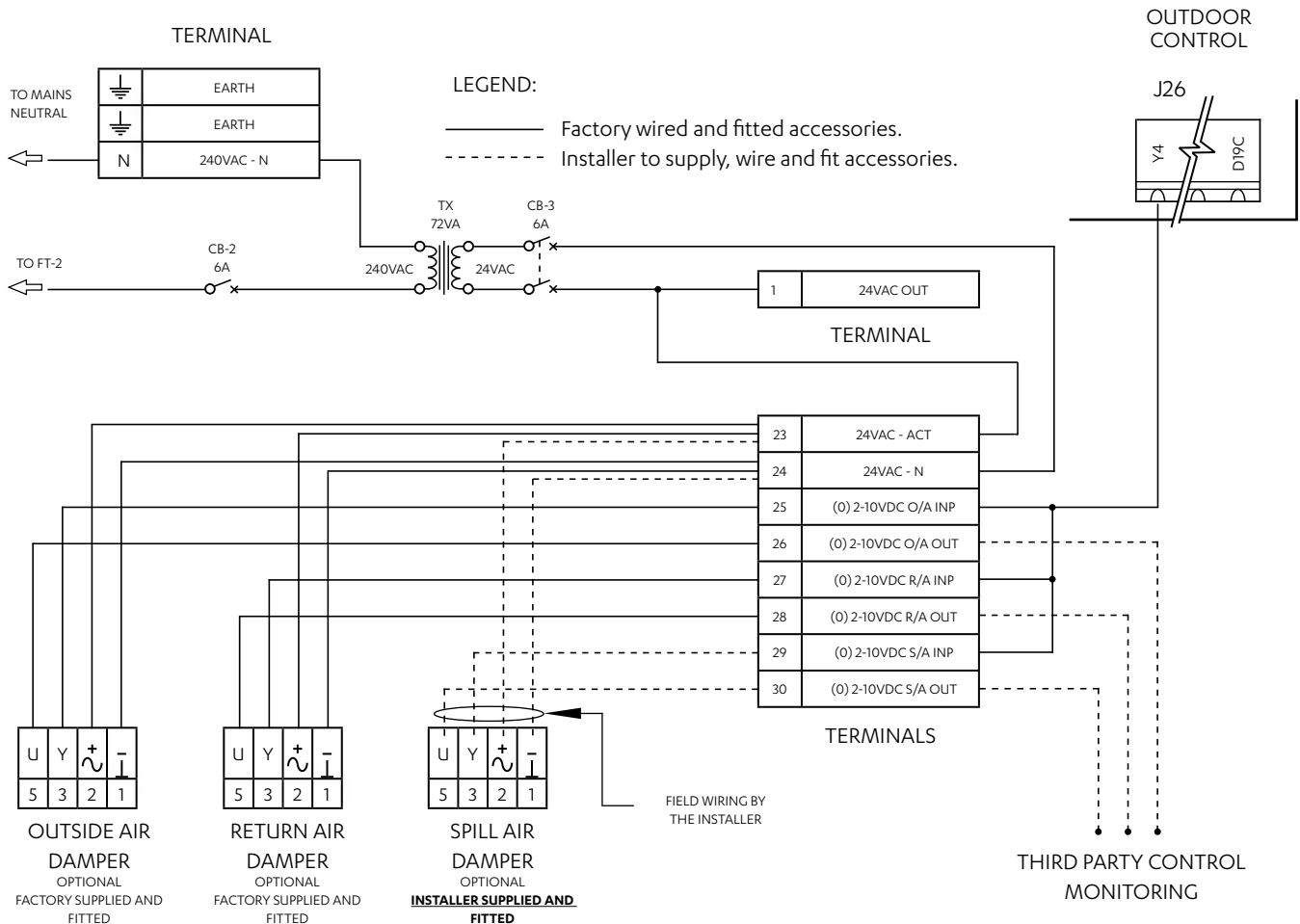

**RETURN AIR - OUTSIDE AIR - SPILL AIR CONTROL CONNECTION DIAGRAM**

## 13.05. Demand Response Management

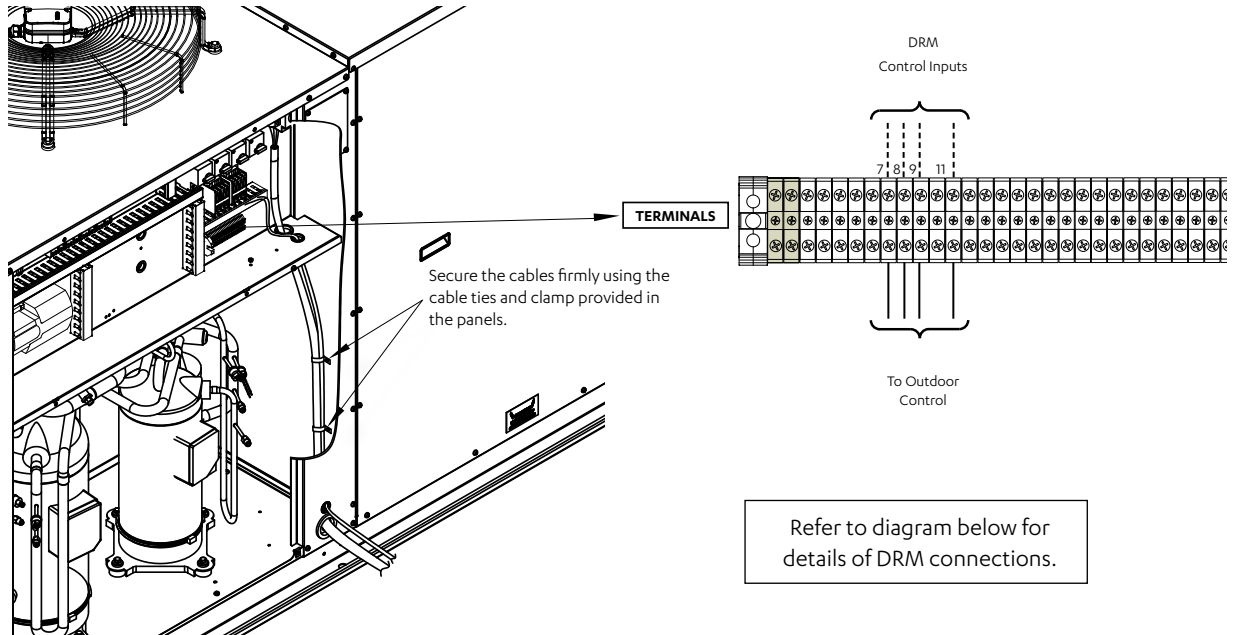

### 1. Thread and Route the DRM input cables into the Unit

- Thread and Route cables as per previous wiring installation procedures.

### 2. Connect cables into the terminals

- Connect cables as shown above and as per wiring diagram provided with the unit.

Demand Management Mode	Description Of Mode	Operating Mode
DRM1	Compressor Off	Compressors ONLY will cycle OFF and remain off for the entire Demand Response Event.
DRM2	Maximum 50% power use mode. (Over each 1/2 hour period)	Compressor 1 operation only for the total Demand Response event.
DRM3	Maximum 75% power use mode. (Over each 1/2 hour period)	Compressor 2 operation only for the total Demand Response event.

OUTDOOR CONTROL

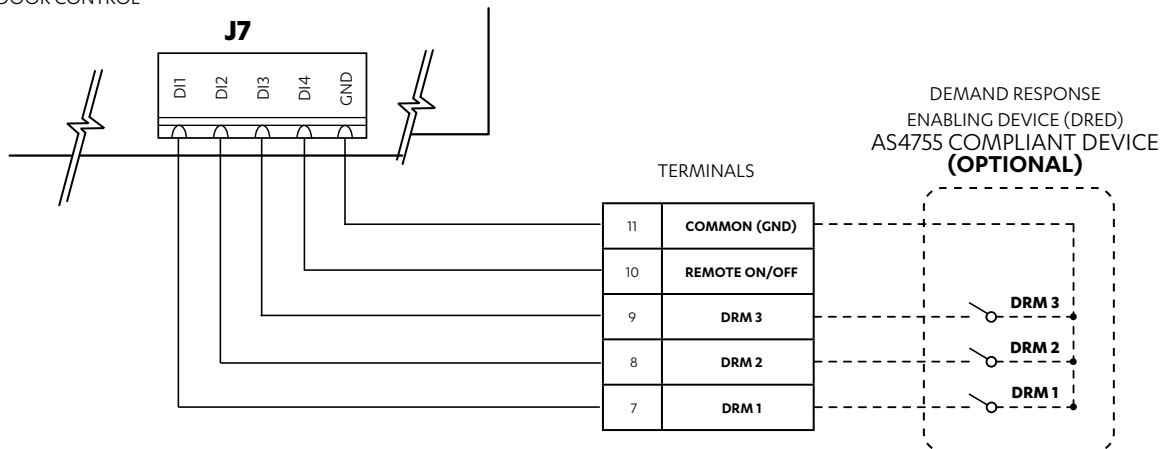

**DEMAND RESPONSE MANAGEMENT CONNECTION DIAGRAM**

## 14. CONTROL MENU

### 14.01. Menu Navigation

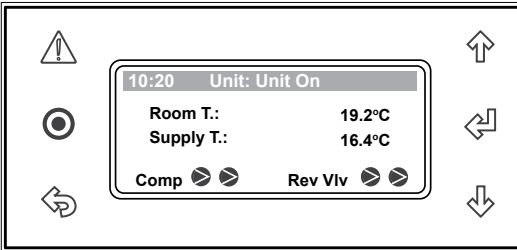

Pressing at anytime will bring the menu back one level up.  
 Pressing at anytime will bring back the main menu.  
 Pressing will display an active alarm (if any).  
 Button will blink if any system alarm is active.

Example below will show the navigation to screen **Gfc2. Thermoregulat.**

**G. Service** → **Gf. Service settings** → **Gfc. Thermoregulation** → **Gfc2. Thermoregulat.**

- To get into the main menu in the control interface, press . The display will show the list of available submenus. Press or button to scroll through the sub menus and select **G. Service**. Press to enter the submenu.

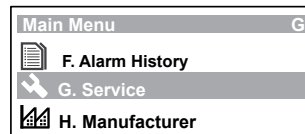
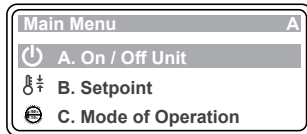

- Press or button to scroll to menu **Gf. Service settings** then press . Press or button to scroll to menu **Gfc. Thermoregulation** then press .

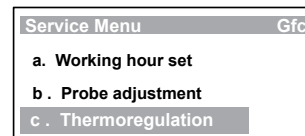
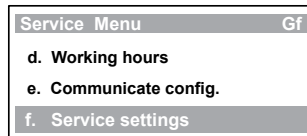

- Press or button to scroll to menu **Gfc2. Thermoregulat.** then press . Set the fields based on desired configuration.

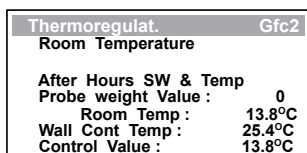

### 14.02. Service Password

To access the Service Settings pages a password is required: **7378**

**G. Service** → **Gf. Service settings** → **Change password to 7378**

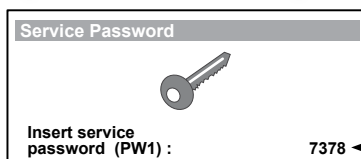

Service Password is shown.

#### WARNING

Unauthorized access to Service Menu and inadvertent changes to the settings can cause damage to the air conditioning system which will render ActonAir warranty null and void.



## 15. MENU TREE

**Note:** To scroll **Up** or **Down** from existing menu, press **↓** or **↑** button.

### 15.01. Main/Status Menu

\*Available when enabled via Service Menu.

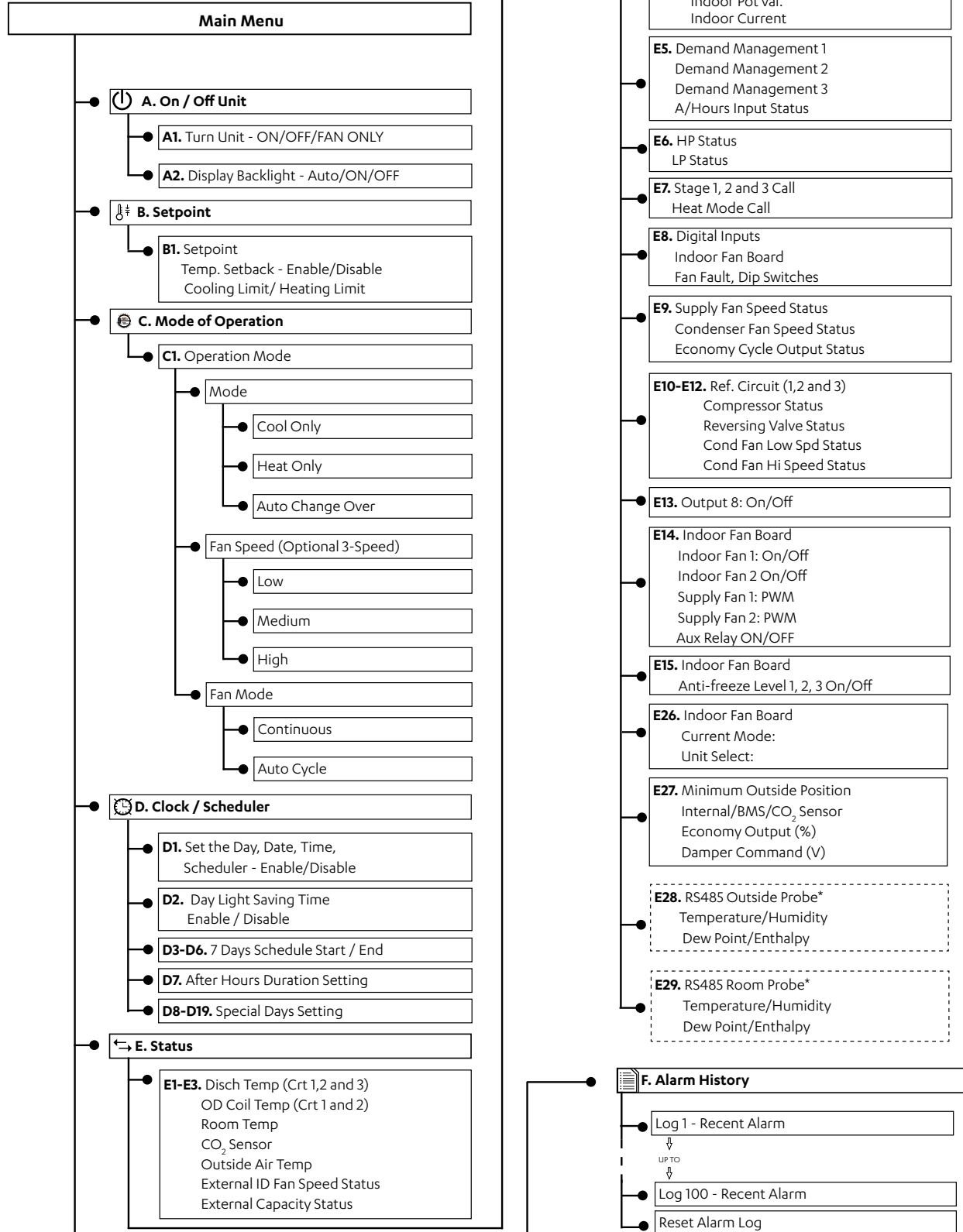

## 15.02. Service Menu

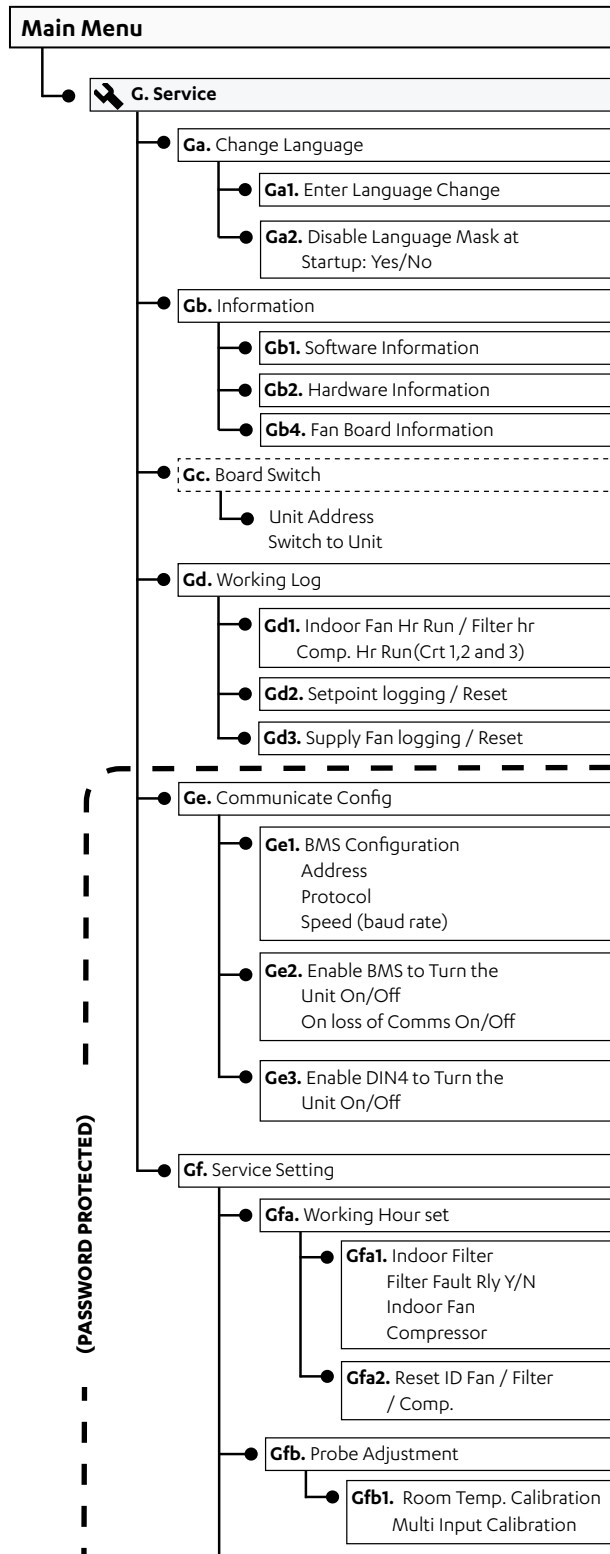

(PASSWORD PROTECTED)

(PASSWORD PROTECTED)

(PASSWORD PROTECTED)

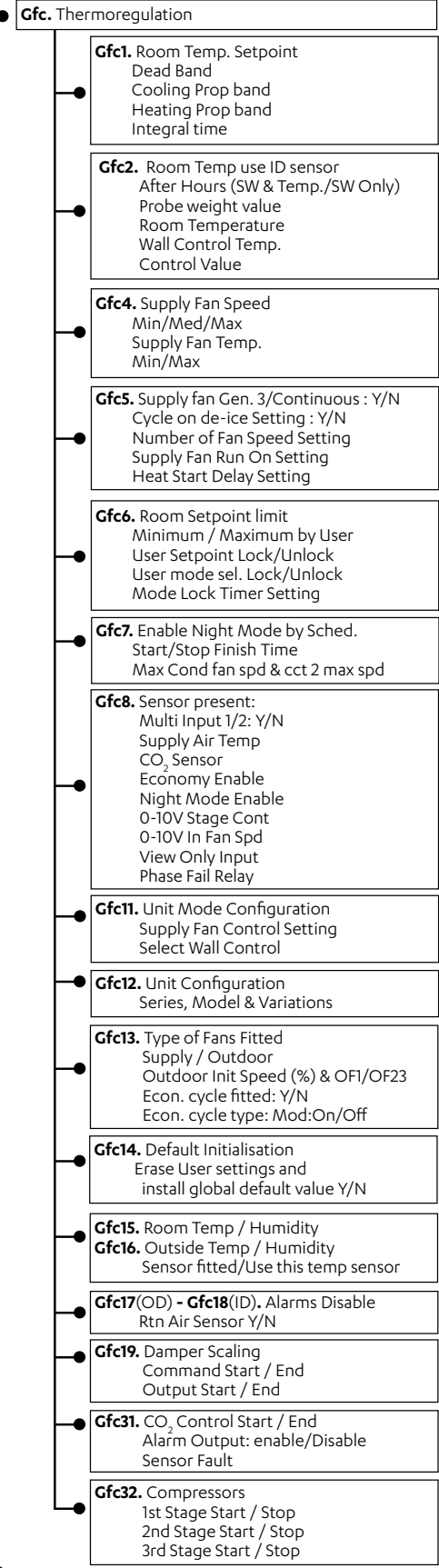

(PASSWORD PROTECTED)

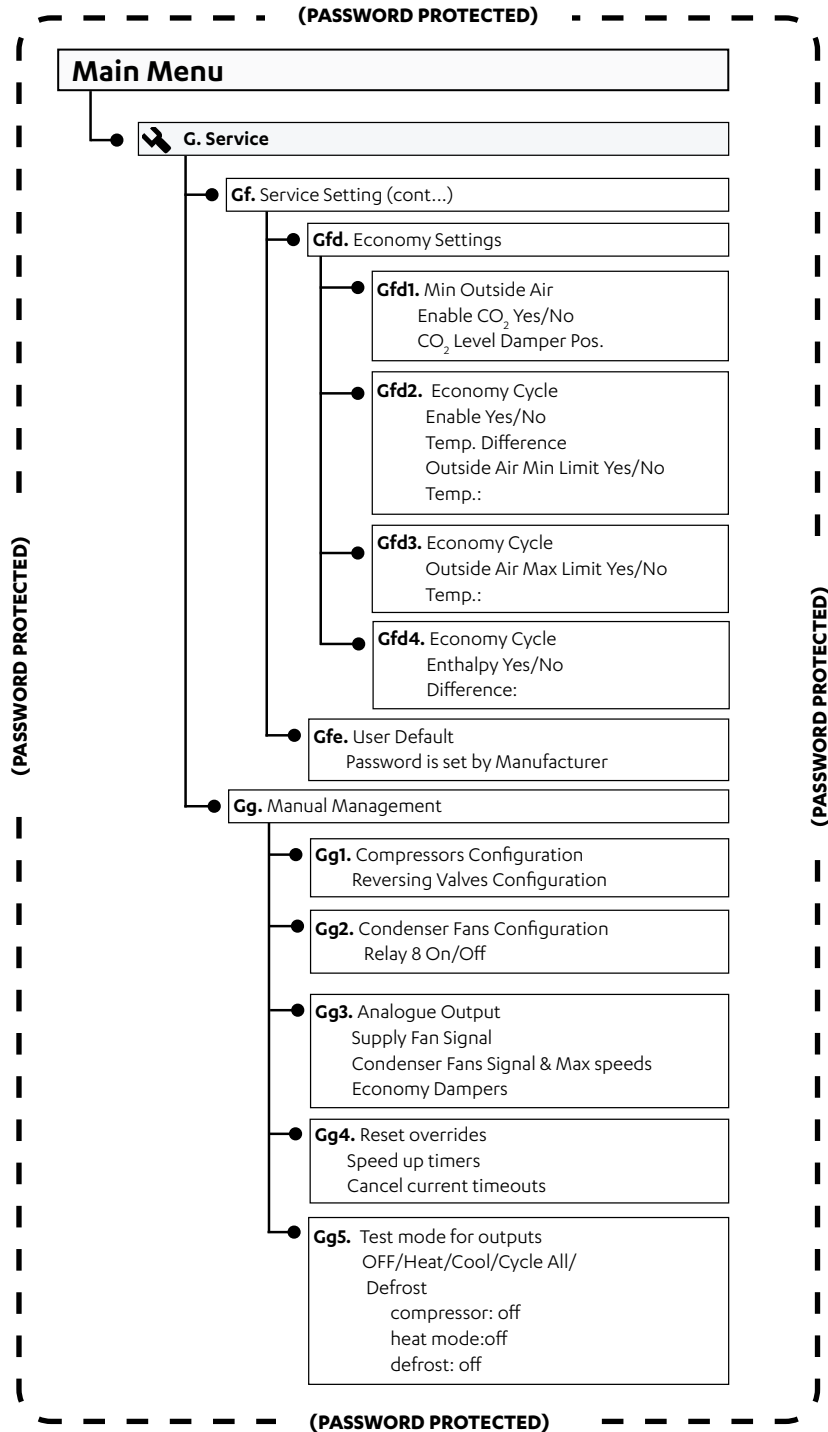

15.03. Manufacturer Menu

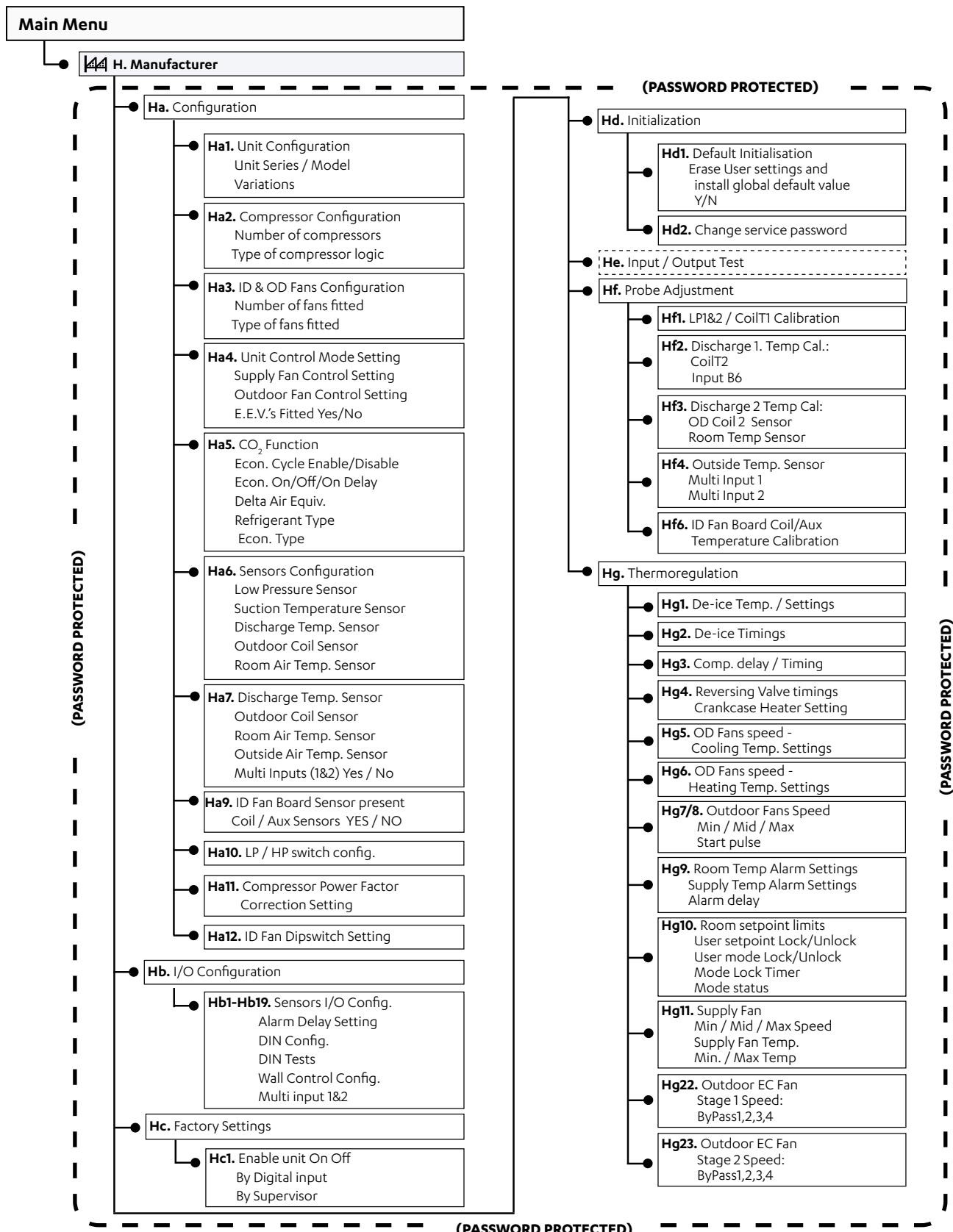

## 16. EXTERNAL INPUT OPERATION

The System is controlled by Third Party Control through wired inputs.

(On/Off, Indoor Fan, Compressor, Heat/Cool and Economy)

REMOTE ON/OFF can only be used when **Enable Scheduler** is set to **NO** (on screen **D1**).

### 16.01. Unit ON/OFF Configuration

The unit ON/OFF can be configured as follows:

#### 16.01.01. Wiring ON/OFF Input

Unit ON/OFF can be wired using either Method 1 (REMOTE ON/OFF) or Method 2 (IN-FAN (24 VAC IN)) as shown below:

##### Method 1:

Unit ON/OFF is configured by switching **REMOTE ON/OFF** to **COMMON**.

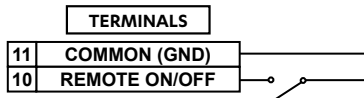

##### Method 2:

IN-FAN is operated by switching 24 VAC. The unit will turn On or Off when the switch is closed or open respectively.

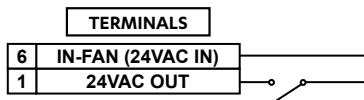

#### 16.01.02. Setting ON/OFF Input

Set **Enable DIN 4 to turn the unit On/Off** : to **Yes**.

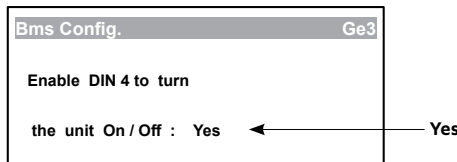

The Unit ON/OFF is now configured.

### 16.02. Indoor Fan External Control

Indoor Fans can be configured to be controlled via a 0-10VDC external input.

#### NOTES

- Commissioning of the EC Fans should be carried out by a qualified technician only.
- Make sure that all instructions are followed accordingly.
- Ensure that connecting duct work and air filters are installed accordingly.

1. Refer to Section 25 for Fan Performance Data or the Fan Curve specific to your air conditioner.
2. Determine the Required Fan Speed (%) which matches your Airflow and External Static Pressure requirements using either the Fan Performance Data or the Fan Curve.

**Example:**

Unit Model: **PKY620T**

Airflow: 3200 l/s

External Static Press: 100 Pa

Required Fan Speed: 62.9%

The Required Fan Speed shall be used to commission the indoor fan.

**Configuration Procedure:**

- a. On screen **C1**, set the **Fan Mode** to operate in either **Continuous** or **Auto cycle** (Auto cycle will cycle the indoor fans on/off with the compressor).

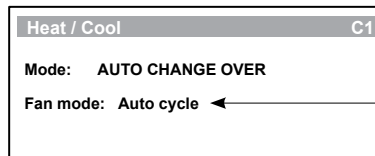

Select **Auto Cycle** or **Continuous** Indoor Fan operation

- b. Enable the **Multi Input 1 (U11)** to the Indoor Fans via **S. Configuration** screen **Gfc8**.

**G. Service** → **Gf. Service settings** → **Gfc. Thermoregulation** → **Gfc8. S. Configuration**

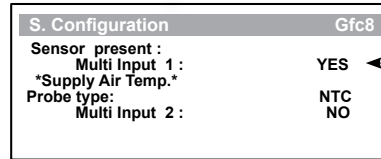

Change Multi Input 1 to **YES**

**NOTE:** **Multi Input 2 (U12)** can also be enabled, in lieu of Multi Input 1, if not used for other system Components.

- c. Configure **Multi Input 1 (or Multi Input 2)** to 0-10VDC Fan Speed and Probe type to **0-10V**:

**G. Service** → **Gf. Service settings** → **Gfc. Thermoregulation** → **Gfc8. S. Configuration**

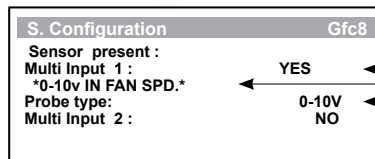

Change to **0-10v IN FAN SPD.**  
Change Probe type to **0-10 V**

- d. Set the Supply Fan type to **VARI SPEED** via **S. Configuration** screen **Gfc13**:

**G. Service** → **Gf. Service settings** → **Gfc. Thermoregulation** → **Gfc13. S. Configuration**

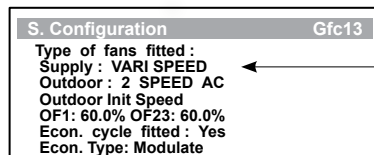

Change to **VARI SPEED**

- e. Set the unit control mode to **EXTERNAL INPUT** and set the **Supply Fan Control** to External via **S. Configuration** screen **Gfc11**:

**G. Service** → **Gf. Service settings** → **Gfc. Thermoregulation** → **Gfc11. S. Configuration**

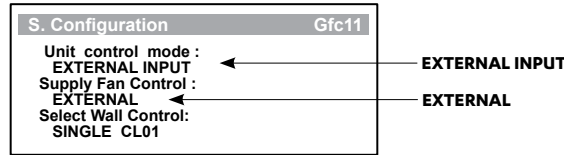

**NOTE:** The Indoor Fans are now configured/ready to be controlled through external 0-10VDC input.

## NOTES

- Refer to Section 16.02 (a) Indoor Fan Operation Modes for configuring the Indoor Fans in either Continuous Mode or Auto Mode.
- If there is no voltage supplied to the indoor fan and it is selected as continuous, the fan will run on the minimum speed for the selected unit model when the unit is On.
- The requested external fan speed value will be displayed on the status menu as Voltage x 100 e.g. 5.9 volts will be displayed as 590 on the capacity screen.

**Main Menu** → **E. Status** → **E2. Input / Output**

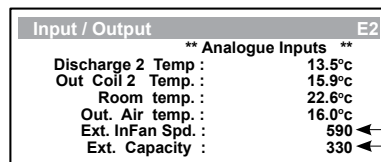

If the Indoor Fan External Control is set via Multi Input 1, the status screen will show **Ext. InFan Spd**.

If the Compressors 0-10VDC External Control Mode is set via Multi Input 2, the status screen will show **Ext. Capacity**. e.g. 330=3.3V or 33% Spd

## 16.03. Compressor Configuration

External input modes can be set up as per table below:

Component	External Input Configuration	Compressor Configuration Procedure	Wiring Diagram
Compressors	24VAC	16.03.01	24.01
	0-10VDC	16.03.02	24.02

To configure the External Input of Compressors control combination, perform the specific configuration procedure for the Compressors, as detailed below:

Unit control mode is set to **EXTERNAL INPUT** via **Gfc11** screen.

**G. Service** → **Gf. Service settings** → **Gfc. Thermoregulation** → **Gfc11. S. Configuration**



On screen **C1**, set the **Mode** to **AUTO CHANGE OVER**, so the Third Party Control will have full control of the compressor operation.

By setting the mode to **Cool only** will restrict the compressor operation to **Cool only**.

By setting the mode to **Heat only** will restrict the compressor operation to **Heat only**.

Auto cycle will cycle the indoor fans on/off with the compressor.

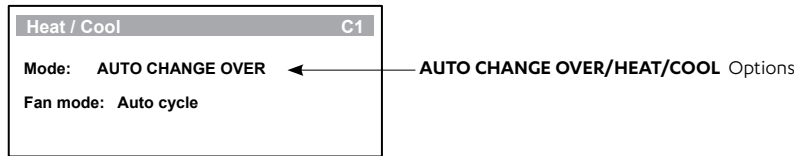

### 16.03.01. Compressors 24VAC External Control Mode

Compressors are configured through a 24VAC input from the external control. This is the **DEFAULT** compressor configuration. If this is the compressor external input requirement, no control interface configuration is required. Refer to the wiring diagram for wiring connection.

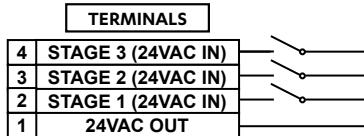

### 16.03.02. Compressors 0-10VDC External Control Mode

Compressors can be controlled through a 0-10VDC input from the external control.

#### NOTE

If a 0-10V input is required the multi-input must be changed as shown per procedure.

#### Compressors Configuration Procedure for 0-10VDC External Control Mode:

Assign a Multi Input to the Compressors via **S. Configuration** screen **Gfc8**:

**G. Service** → **Gf. Service settings** → **Gfc. Thermoregulation** → **Gfc8. S. Configuration**

Ensure that the Multi Input assigned to the Compressors is set to **\*0-10v STAGE CONT.\*** and the Probe type: is set to **0 - 10V**.

**G. Service** → **Gf. Service settings** → **Gfc. Thermoregulation** → **Gfc8. S. Configuration**

Example shown below is for Compressors with external input assigned to Multi Input 2:

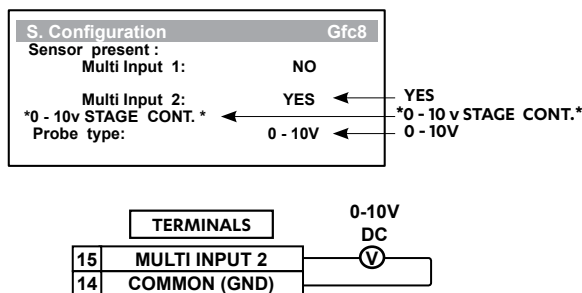



## NOTE

For W-3 Phase Sequence Relay Option, Multi Input 2 (U12) is already used for 24VAC supply. Multi Input 1 (U11) must be used instead.

### Multi Input 1 and Multi Input 2 state

Examples of equivalent voltage and capacity scaling are as follows:

3V = 33% capacity (stage 1); 6V = 66% capacity (stage 2); 9 = 100% capacity (stage 3)

Main Menu → E. Status → E2. Input/Output

Input / Output		E2
** Analogue Inputs **		
Discharge 2 Temp :	13.5°C	
Out Coil 2 Temp. :	15.9°C	
Room temp. :	22.6°C	
Out. Air temp. :	16.0°C	
Ext. InFan Spd. :	590	←
Ext. Capacity :	330	←

If Multi Input 1 is configured (as per Section 16.02 (b, c and d)):  
External indoor fan speed set on the Third Party Control will be displayed.

If Multi Input 2 is configured (as per Section 16.03.02):  
External capacity set on the Third Party control, will be displayed on the Control Interface  
e.g. 330 = 3.3 V or 33% Spd

### 16.03.03. Unit Heat Digital Input

Heating is operated by switching 24VAC. The unit will run in heating when the switch is closed. Note that the compressor requires separate signal. Refer to Section 16.03.



### 16.03.04. Economy Cycle On/Off Digital Input

In this mode of Damper operation (On/Off), the damper will be:

1. Closed when the unit is OFF.
2. Open to **Max Outside Air Damper (100%)** position when **Multi Input 1** (or 2) is switched to GND (0V) and the unit is ON.
3. Open to **Min Outside Air Damper** position when **Multi Input 1** (or 2) is open (disconnected from GND (0V)) and the unit is ON.

Set the **Econ. type** to **ON/OFF** on **Gfc13**

S. Configuration		Gfc13
Type of fans fitted	Supply : 3 SPEED (EC)	
Outdoor : VARI SPEED	Outdoor Init Speed	
OF1: 60.0% OF23: 60.0%	Econ. cycle fitted :	Yes
Econ. type :		ON / OFF

Setup **Multi Input 1** (or 2) to **ECONOMY ENABLE** and **Probe type** to **ON/OFF** as shown below:

G. Service → Gf. Service settings → Gfc. Thermoregulation → Gfc8 S. Configuration

S. Configuration		Gfc8
Sensor present :	Multi Input 1 :	YES
*ECONOMY ENABLE *	Probe type :	*ECONOMY ENABLE*
Multi Input 2 :		ON/OFF
		NO

Switch **Multi Input 1** (or 2) to **COMMON (GND)** to operate the Economy Cycle (Maximum Outside Air)

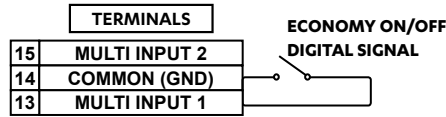

### 16.03.05. Min. Outside Air: (Configurable in Gfd1 screen)

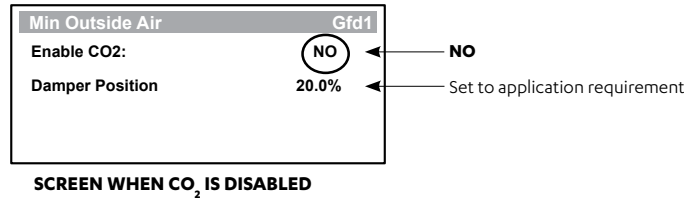

## 17. INTERNAL SENSOR OPERATION

The System is controlled by the ActronAir CM100 control.  
(On/Off, Indoor Fan, Compressor, Heat/Cool and Economy)

### 17.01. Unit Control Configuration

Set the unit control mode to **INTERNAL SENSORS** via Service menu:

**G. Service** → **Gf. Service settings** → **Gfc. Thermoregulation** → **Gfc11. S. Configuration**

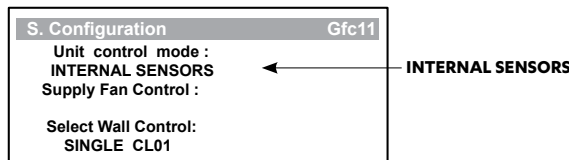

### 17.02. Unit ON/OFF Configuration

The unit ON/OFF can be configured to one of the following:

- Option 1:** MANUAL ON/OFF
- Option 2:** TIME SCHEDULER
- Option 3:** EXTERNAL UNIT ON/OFF

Unit status will be shown on the Main Menu. Screen below shows Unit status as Unit On.

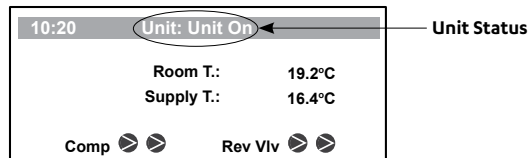

### Option 1: MANUAL ON/OFF

Ensure that **Enable DIN 4 to turn the unit On/Off** : is set to **NO**.



Turn **ON** or **OFF** the unit on screen **A1** when required.

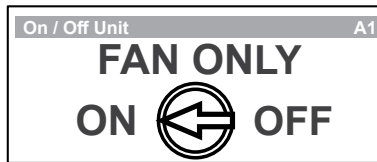

### NOTE

Selecting **FAN ONLY** will turn on the supply fan without compressor operation.

The Unit ON/OFF is now configured.

Unit ON/OFF CP05 (CP10, CL01 optional)	Unit Status
ON	Unit On
OFF	OFF by KEY

### Option 2: TIME SCHEDULER

Ensure that **Enable DIN 4 to turn the unit On/Off** : is set to **NO**.

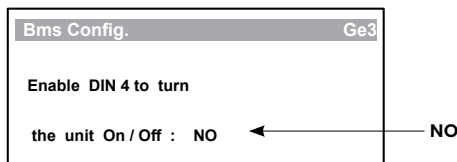

Ensure **Enable Scheduler** (on screen **D1**) must be **Yes**.

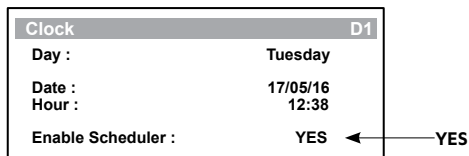

Then set the weekly, After Hours and special days time scheduler via screens (**D3 – D19**) to your requirements.

The Unit ON/OFF is now configured.

Unit ON/OFF CP05 (CP10, CL01 optional)	SCHEDULE	UNIT STATUS
ON	ON	Unit On
ON	OFF	OFF by SCH
OFF	ON or OFF	OFF by KEY

### Option 3: External Unit ON/OFF

The Unit ON/OFF can be controlled via external relay.

Unit ON/OFF CP05 (CP10, CL01 optional)	REMOTE ON/OFF	UNIT STATUS
ON	ON	Unit On
ON	OFF	OFF by DIN
OFF	ON or OFF	OFF by KEY

### 17.02.01. Wiring ON/OFF Input

Unit ON/OFF can be wired using either **Method 1: External Unit ON/OFF** or **Method 2: IN-FAN (24VAC IN)**.

#### Method 1: External Unit ON/OFF

External Unit ON/OFF is operated by switching **REMOTE ON/OFF** to **COMMON**.

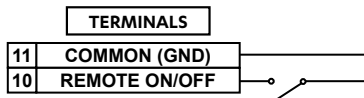

#### Method 2: IN-FAN (24VAC IN)

External Unit ON/OFF is operated by switching **24VAC** to **IN-FAN** terminal.

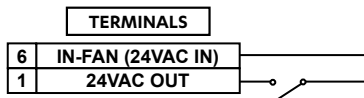

### 17.02.02. Setting ON/OFF Input

Set **Enable DIN 4 to turn the unit On/Off** (on screen **Ge3**) to **Yes**.

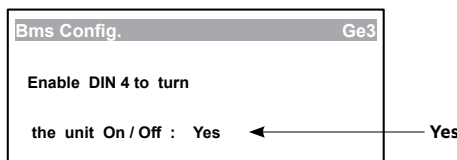

**Enable Scheduler** (on screen **D1**) must be **No**.

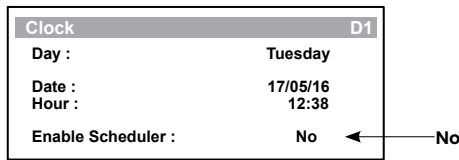

Ensure **ON/OFF Unit** (on screen **A1**) is **ON**.



The Unit ON/OFF is now configured.

### 17.03. Indoor Fan Configuration

#### NOTES

- Commissioning of the EC Fans should be carried out by a qualified technician only.
- Make sure that all instructions are followed accordingly.
- Ensure that connecting duct work and air filters are installed accordingly.

#### Indoor EC Fan Speed setting/Commissioning Procedure via Control Interface

1. Refer to the Fan Performance Data or the Fan Curve specific to your air conditioner.
2. Determine the Required Fan Speed (%) which matches your Airflow and External Static Pressure requirements using either the Fan Performance Data or the Fan Curve.

#### Example:

Unit Model: **PKY620T**

Airflow: 3200 l/s

External Static Press: 100 Pa

Required Fan Speed: 62.9%

3. Use this Required Fan Speed % to set the medium speed via the control interface, following the menu navigation:

**G. Service** → **Gfc. Service Settings** → **Gfc. Thermoregulation** → **Gfc4. Thermoregulat. (Supply Fan Settings)**.

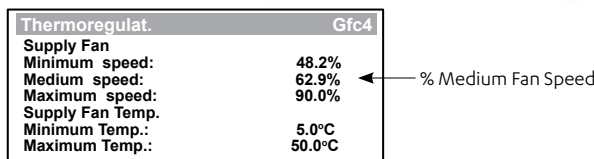

#### NOTES

- Minimum and Maximum fan speeds are factory default settings.
- Medium fan speed is the nominal operating fan speed which can be adjusted between the minimum and maximum speed.

## 18. SETTING UP BMS (REMOTE DEMAND) OPTIONAL

For optional BMS (Remote Demand) Optional Mode, see Installation and Commissioning Guide (0525-036).

## 19. SETTING ECONOMY CYCLE OPERATION

The Economy mode is based on Dry Bulb  $\Delta T$  logic only and operates when cooling is required.

The conditions for Economy Cycle are required to be satisfied for a continuous period of 180s to start the Economy Cycle operation.

The Economy Cycle operation will continue to operate for at least 180s duration.

### 19.01. Setting Economy Cycle Type

The economy cycle operation can be set via the Control Interface as follow:

**G. Service** → **Gf. Service settings** → **Gfc. Thermoregulation** → **Gfc13 S. Configuration**

By default Econ. type is set to **MODULATE**. In this setting, ActronAir internal control logic modulates the damper positioning.

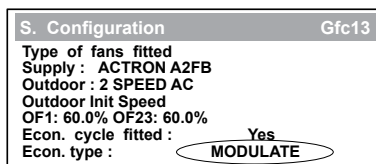

#### 19.01.01. Min Outside Air: (Configurable in Gfd1 screen)

Set the minimum damper positioning:

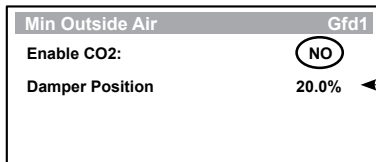

← This must be set to Application Requirements Range (0-99%)

To use ActronAir CO<sub>2</sub> sensor, refer to the Document Part No: 9590-3011.

#### 19.01.02. Enable Economy Cycle: (Configurable in Gfd2 screen)

To use the Economy Cycle logic, set Enabled to **YES** as shown below.

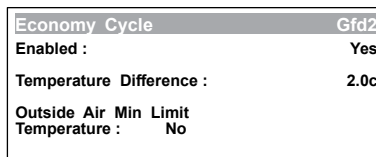

← Yes

### NOTE

In some cases, 1 or 2 Humidity Sensors may need to be setup and connected.

### 19.01.03. Temperature difference to enable cycle: (Configurable in **Gfd2** screen)

This setting is the difference required between the **Room Air Temp.** ( $T_{Room}$ ) and the **Outside Air Temp.** ( $T_{Outside Air}$ ). For example, if  $(T_{Room} - T_{Outside Air})$  Temperature Diff  $> 2.0^{\circ}C$  (Default) then the economy cycle will be activated.

**Settings:** Min =  $-2.0^{\circ}C$ , Max =  $9.9^{\circ}C$ , Default =  $2.0^{\circ}C$

### 19.01.04. Minimum Outside Air Temp.: (Configurable in **Gfd2** screen)

To use this option, set **Outside Air Min Limit Temperature** to **Yes**. If the  $T_{Outside Air} < \text{Outside Air Min Limit Temperature}$ , the economy cycle will stop, and the damper will remain open at the minimum opening value set by the **Min Outside pos**.

**Settings:** Min =  $0.0^{\circ}C$ , Max =  $25.0^{\circ}C$ , Default =  $14.0^{\circ}C$

Economy Cycle		Gfd2
Enabled :		Yes
Temperature Difference :		2.0c
Outside Air Min Limit Temperature :	Yes	14.0c

### 19.01.05. Maximum Outside Air Temp.: (Configurable in **Gfd3** screen)

To use this option, set **Outside Air Max Limit Temperature** to **Yes**. If the  $T_{Outside Air} > \text{Outside Air Max Limit Temperature}$ , the economy cycle will stop, and the damper will remain open with maximum opening value set by **Min Outside pos**.

**Settings:** Min =  $0.0^{\circ}C$ , Max =  $25.0^{\circ}C$ , Default =  $16.0^{\circ}C$

Economy Cycle		Gfd3
Outside Air Max Limit Temperature :	Yes	16.0c
Humidity :	No	
Enthalpy :	No	
Dew Point:	No	

## NOTE

To use humidity sensor option in economy cycle, refer to Humidity Sensor Installation and Commissioning Guide.

**19.02. Calibration Damper Opening**

Damper Scaling: (Configurable in **Gfc19** screen)

The Damper opening calibration can be configured through Service Menu **Gfc19**.

This is pre-configured for 2-10V modulating damper motors.

The graph shows the conversion of Outside Air Damper Command (Start and End) to Output Voltage (Start and End) which is connected to the damper motor signal input.

This Output Voltage scaling is used for both Minimum Outside Air and Economy Cycle operation.

**NOTE**

The Output Voltage is set to 0V when the system is off.

Economy Cycle		Gfc19
<b>Damper Scaling</b>		
Command Start:	0%	
Command End:	100%	
Output Start:	20%	
Output End:	100%	

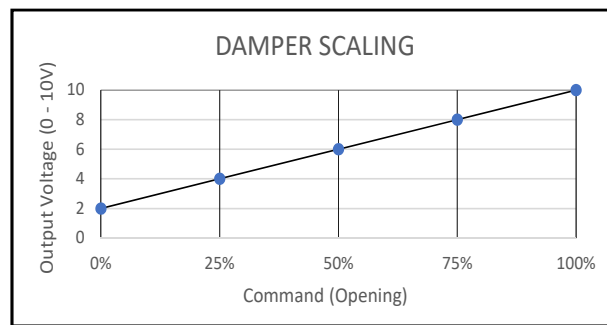

**20. ROOM AIR TEMPERATURE SENSOR INSTALLATION**

**NOTES**

- Install the Room Air Temperature Sensor in the most suitable location to ensure adequate sensing.
- Ensure that the sensor is located where the room air is not affected by other heat sources.
- The Room Air Temperature Sensor must be properly secured in the chosen location.
- The Sensor wire should be routed securely and not to be exposed to sunlight, rain, dust and other contaminants.
- Ensure the sensor cable is ran separately to any low/high voltage cables to avoid interference.

**Package Unit Air Temperature Sensor**

The Room Air Temperature Sensor is not pre-installed with the unit. The Room Air Temperature Sensor is kept in the plastic pack together with installation manuals. To install the provided sensor, follow these steps:

- Take out the Room Air Temperature Sensor from the document pack.
- Strip the cable to expose the wires.

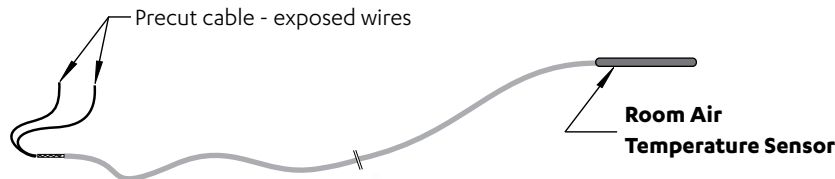



c. Connect the sensor wires to the Outdoor Terminals:

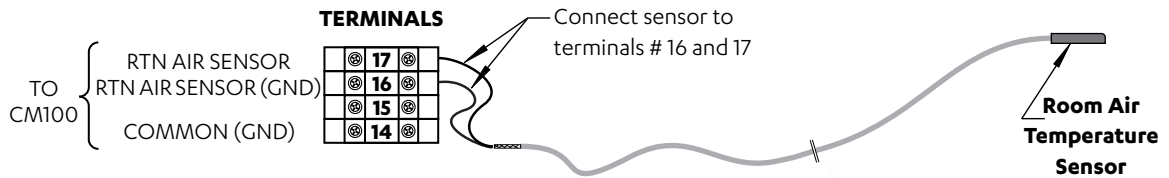

### NOTES

- The supplied Room Air Temperature Sensor (ActronAir Part Number: 2060-036) is a Duct Bead type sensor on the CP05/CP10 display. A wall type sensor is also available as an option (ActronAir Part Number: LM-RS-2).
- For longer installation requirements, it is possible to extend the provided 6m sensor lead wire with an extension wire. The extension wire **MUST** comply to the specifications on Section 21.01 and the installer is required to adjust the sensor to get correct reading.

## 21. ROOM AIR TEMPERATURE SETUP IN CONTROL INTERFACE

Below procedures show how to set up the air temperature sensors depending on terminal location.

### 21.01. Averaging Four Room Air Temperature Sensors (Optional)

Additional sensors may be purchased separately from ActronAir.

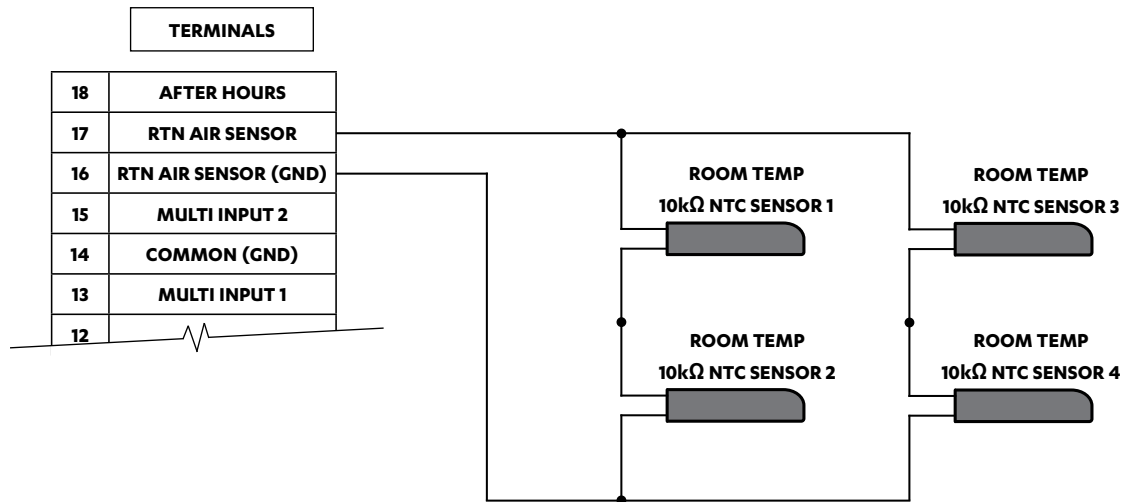

#### Specifications - Sensor Lead Wire

Item	Distance	
	up to 50m	up to 100m
NTC (Sensor Wire) *	0.5mm <sup>2</sup>	1.0mm <sup>2</sup>

\* For compliance with EMC requirements, connect the screen wire to Terminal 22 on the Outdoor Terminal Strip.

Use only the provided ActronAir duct bead sensor or the optional wall sensor.

Use of third party sensors are done at the contractors' risks and ActronAir accepts no responsibility for performance or sensing issues.

**21.02. Setting up the Room Air Temperature**

To setup the Room Air Temperature Sensor (connected to **RTN AIR SENSOR** and **RTN AIR SENSOR (GND)** terminals), ensure the **Probe weight Value** is set to **0** as shown below:

Enter **G. Service Menu**

**G. Service** → **Gf. Service settings** → **Gfc. Thermoregulation** → **Gfc2. Thermoregulat.**

Thermoregulat.		Gfc2
Room Temperature		
After Hours SW & Temp		
Probe weight Value	0	
Room Temp :	13.8°C	
Wall Cont Temp :	25.4°C	
Control Value :	13.8°C	

**21.03. Room Temperature Sensor Adjustment Instructions**

To calibrate the Room Air Temperature sensor, follow the service menu steps:

**G. Service** → **Gf. Service settings** → **Gfb. Probe adjustment** → **Gfb1. Calibration**

Calibration		Gfb1
Room Temp cal :	0.0°C	

**Example:**

If the actual measured room temperature is 2.0°C higher than control interface reading, adjust the offset to -2.0°C. Adjustable offset range is from -9.9°C to +9.9°C.

Calibration		Gfb1
Room Temp cal :	+2.0°C	

Enter room air temp. offset here

Probe Adjustment Display

**22. AFTER HOURS LOGIC WITH TIMECLOCK (SCHEDULER)**

**22.01. After Hours wiring to the unit**

**Option 1:** After Hours button wired to the unit.

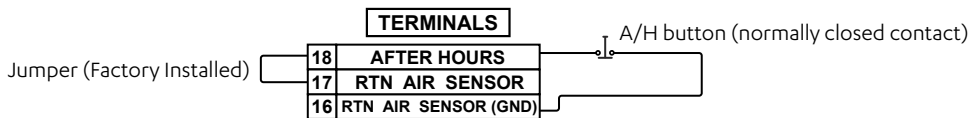

Thermoregulat.		Gfc2
Room Temperature		
After Hours SW & Temp		
Probe weight Value	0	
Room Temp :	13.8°C	
Wall Cont Temp :	25.4°C	
Control Value :	13.8°C	

Use this option if using Indoor/CL01 sensor

**Option 2 :** After Hours button with Room Air Temperature Sensor wired to the unit.

Remove Jumper (Factory installed) wire from terminal 17 and 18.

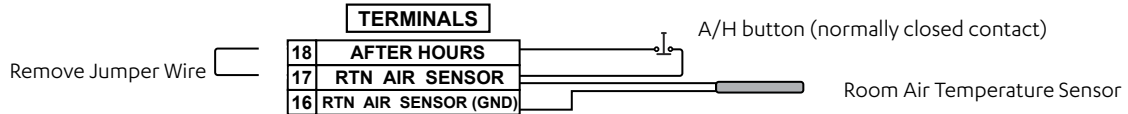

## 22.02. Operational Logic

If the scheduler is enabled, the After Hours function will start when the **AFTER HOURS** button is pressed and held for 5 seconds.

## 23. ENABLE / DISABLE AIR FILTER ALARM

The Tri-Capacity control gives the user the option to Enable / Disable the Air Filter Alarm.

### Procedure:

1. Set the **Indoor Filter** alarm timer in hours. Adjustable range is 0-900 hours.

**G. Service** → **Gf. Service settings** → **Gfa. Working hour set** → **Gfa1. Work. hours set**

Work. hours set	Gfa1
Indoor Filter :	200h
Filter Fault relay:	No
Indoor Fan :	10000h
Compressor :	10000h

Setting **Indoor Filter** to **000h** will disable the filter alarm and notification. At this setting, the output fault relay will not be energised.

2. To enable the Alarm Relay Output (Air Filter cleaning) notification, Set **Filter Fault Relay** to Yes.

**G. Service** → **Gf. Service settings** → **Gfa. Working hour set** → **Gfa1. Work. hours set**

Work. hours set	Gfa1
Indoor Filter :	200h
Filter Fault relay :	Yes
Indoor Fan :	10000h
Compressor :	10000h



## 24.02. 0-10 Analogue Output Compressor and 24VAC Relay Output Indoor Fans

### TRI-CAPACITY CM100 COMMERCIAL CONTROLS 3RD PARTY THERMOSTAT CONTROLLER CONNECTION 0-10V ANALOGUE OUTPUT FOR COMPRESSOR & 24VAC RELAY OUTPUT FOR INDOOR FAN

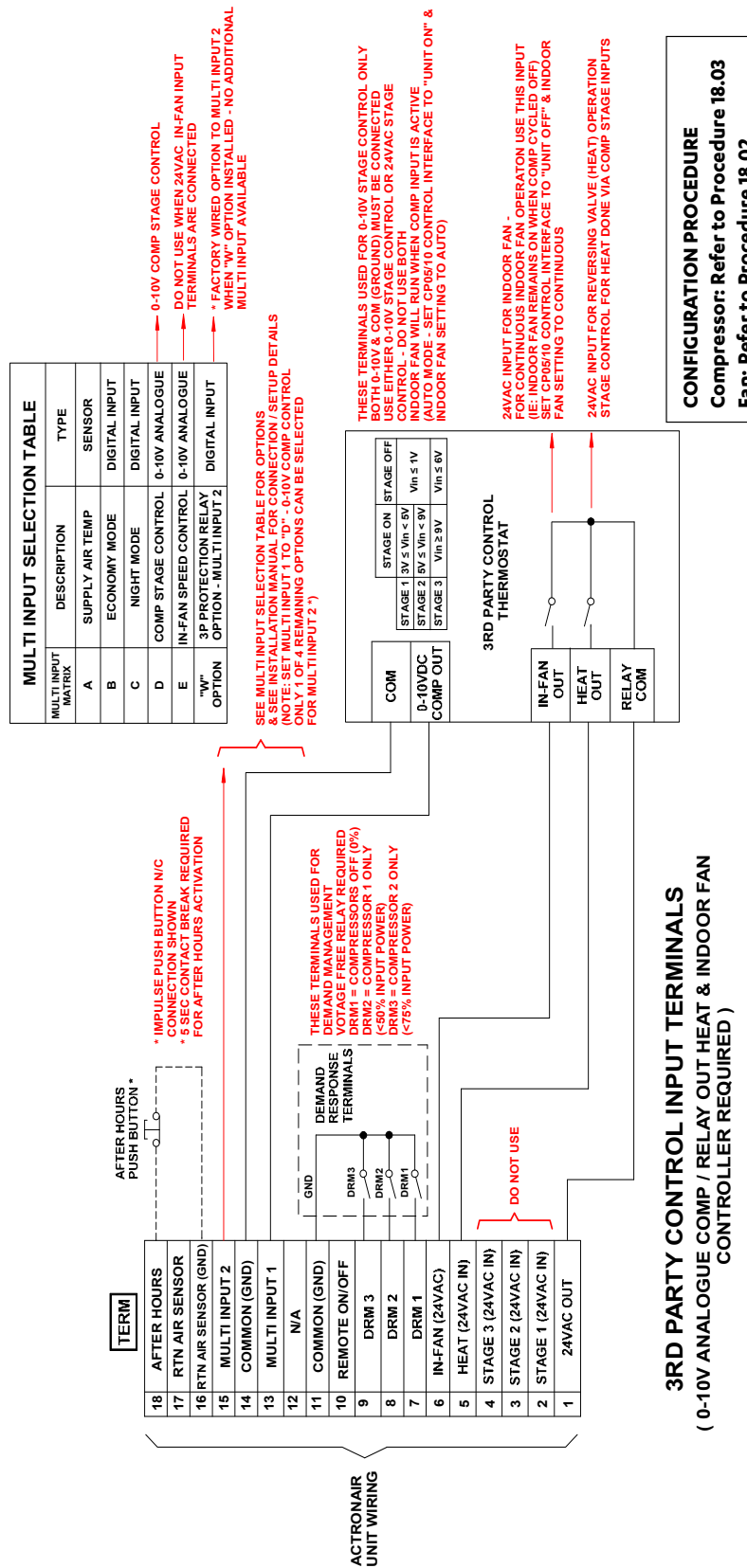

## 24.03. 24VAC Relay Output Compressor and 0-10 Analogue Output Indoor Fans

### TRI-CAPACITY CM100 COMMERCIAL CONTROLS 3RD PARTY THERMOSTAT CONTROLLER CONNECTION 24VAC RELAY OUTPUT FOR COMPRESSOR & 0-10V ANALOGUE OUTPUT FOR INDOOR FAN

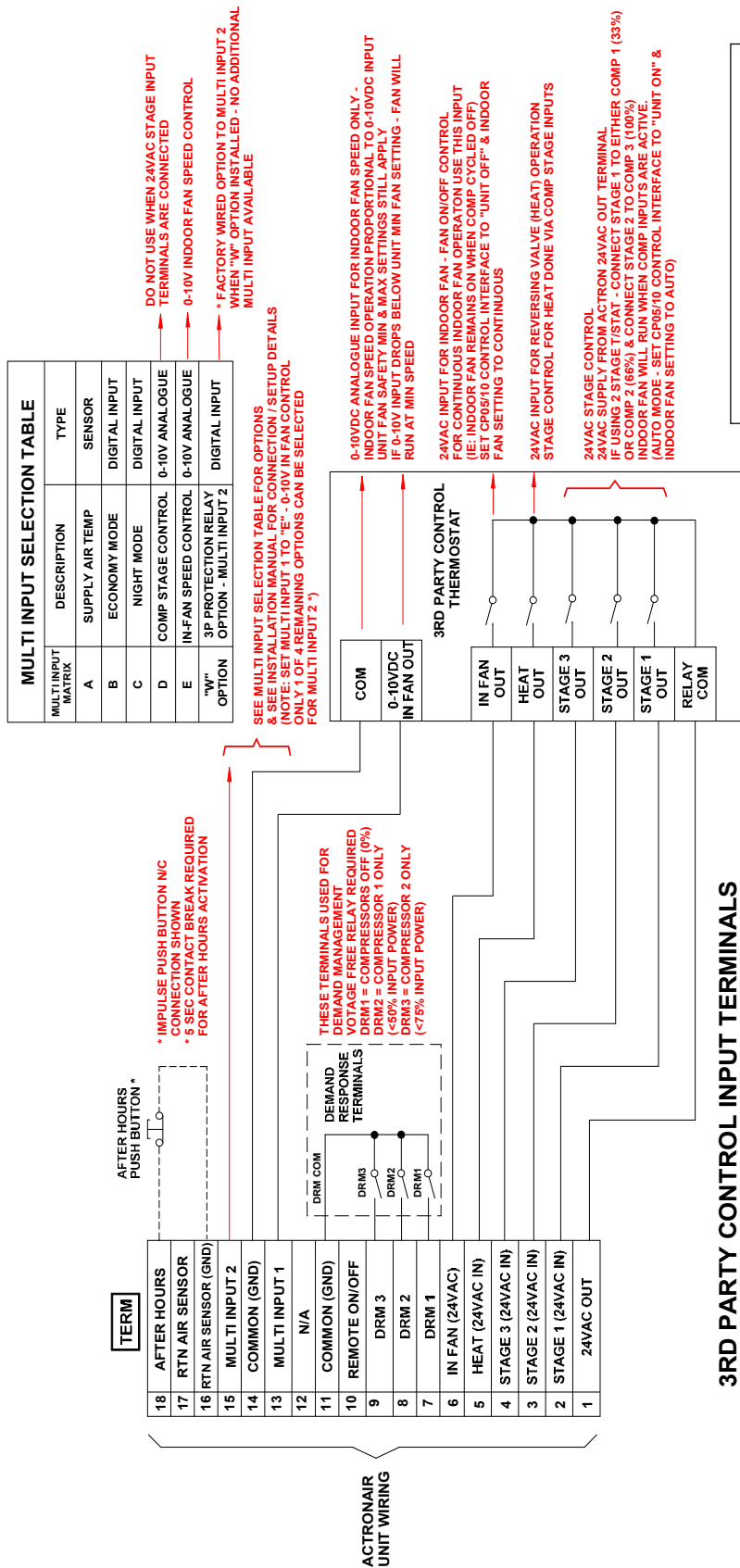

**CONFIGURATION PROCEDURE**  
Compressor: Refer to Procedure 16.03  
Fan: Refer to Procedure 16.02

## 24.04. Wiring Diagram 0-10V Analogue Output Compressors and Indoor Fans

### TRI-CAPACITY CM100 COMMERCIAL CONTROLS 3RD PARTY THERMOSTAT CONTROLLER CONNECTION 0-10V ANALOGUE OUTPUT FOR COMPRESSOR & 24VAC RELAY OUTPUT FOR INDOOR FAN

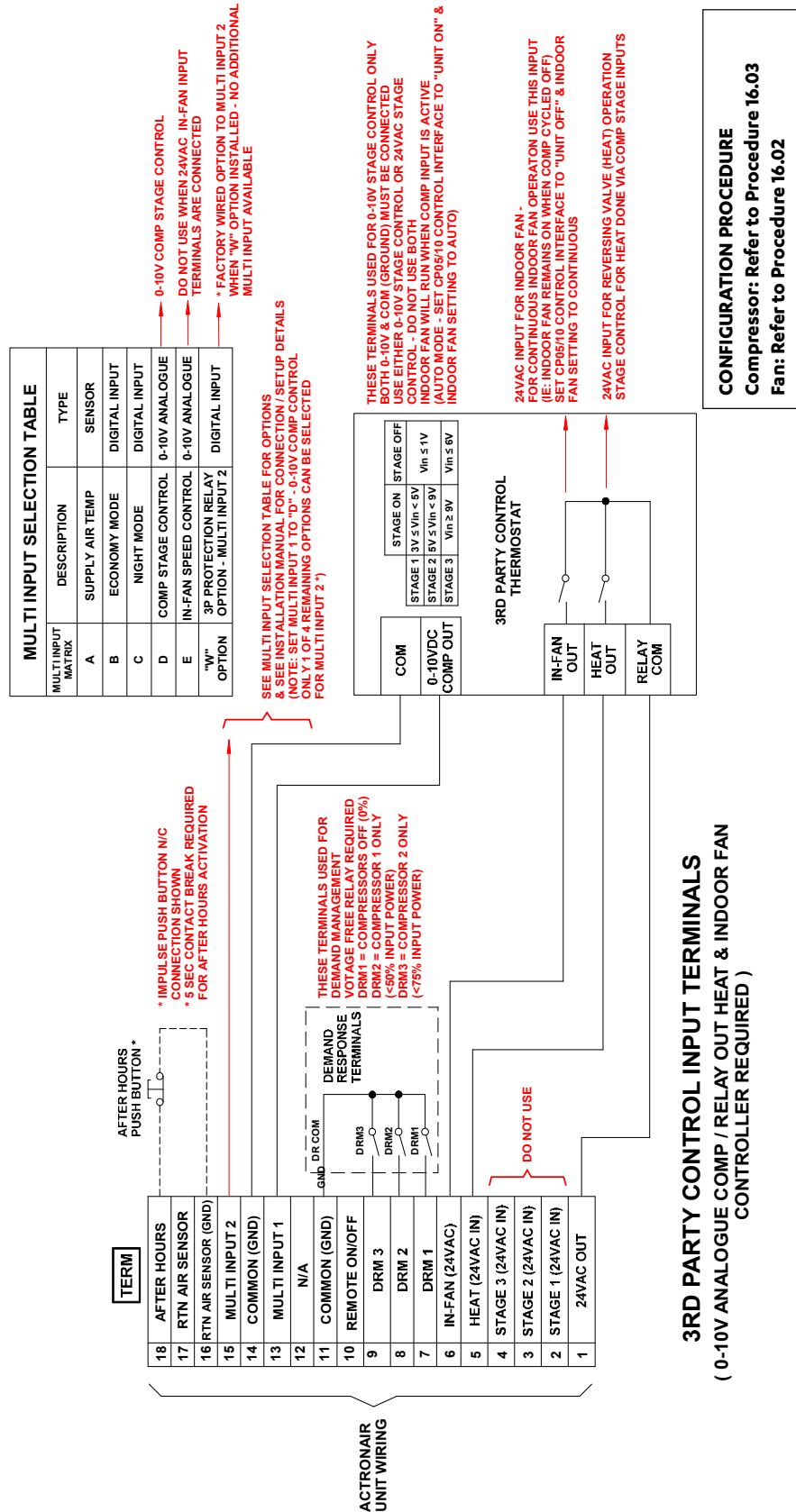

## 25. FAN PERFORMANCE DATA AND CURVE

### FAN PERFORMANCE DATA

PKY500T

Airflow (l/s)	External Static Pressure (Pa)																			
	50		100		150		200		250		300		350		400		450		500	
	% Spd.	W	% Spd.	W	% Spd.	W	% Spd.	W	% Spd.	W	% Spd.	W	% Spd.	W	% Spd.	W	% Spd.	W	% Spd.	W
2000	39.6	525	43.7	685	47.1	842	50.3	1007	53.3	1173	56.2	1350	58.9	1533	61.6	1709	64.4	1885	67.2	2060
2100	41.7	588	45.5	744	48.7	909	51.8	1080	54.8	1253	57.5	1436	60.1	1613	62.9	1792	65.7	1970	68.5	2148
2200	43.8	649	47.2	812	50.4	983	53.4	1158	56.2	1335	58.9	1524	61.5	1698	64.3	1880	67.5	2082	70.9	2295
2300	45.8	714	48.8	875	51.9	1052	55.0	1236	57.6	1422	60.3	1613	63.0	1789	65.9	1976	69.2	2185	72.6	2399
2400	47.5	780	50.5	947	53.6	1134	56.5	1327	59.1	1516	61.8	1699	64.5	1875	67.7	2079	71.1	2295	74.4	2504
2500	49.3	849	52.3	1033	55.3	1220	58.0	1419	60.6	1606	63.4	1786	66.3	1972	69.6	2184	72.4	2410		
2600	51.1	931	<b>54.1</b>	<b>1114</b>	56.8	1305	59.5	1509	62.3	1693	65.0	1865	68.3	2095	71.3	2319	74.1	2546		
2700	53.1	997	55.8	1202	58.4	1400	61.1	1597	63.9	1789	67.0	2007	70.2	2235	73.0	2454				
2800	54.9	1105	57.4	1295	59.9	1485	62.8	1692	65.8	1904	69.0	2121	72.0	2352	74.8	2581				
2900	56.6	1198	59.1	1388	61.9	1591	64.7	1790	67.8	2011	70.9	2242	73.9	2486	<b>MOTOR / BLOWER LIMIT</b>					
3000	58.2	1285	61.0	1492	63.8	1699	66.8	1922	69.9	2153	72.9	2386								
3100	60.2	1394	63.0	1604	65.9	1819	68.9	2034	71.9	2268	74.8	2504								

**NOTES:**

% Speed = Indoor Fan Speed Control Setting, in percent  
(Value is set on the Control Interface via Service Menu \*).

W = Indoor Fan Power, Watts

54.1 - Data in the box indicates Factory Default Setting.

\*Service → Service Settings → Thermoregulation → Thermoregulat. Gfc4

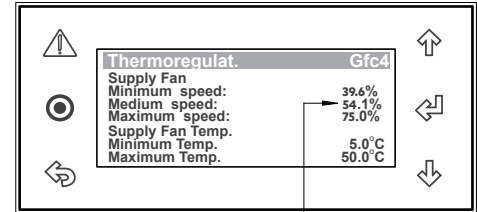

Set Fan Speed

### INDOOR UNIT FAN CURVE

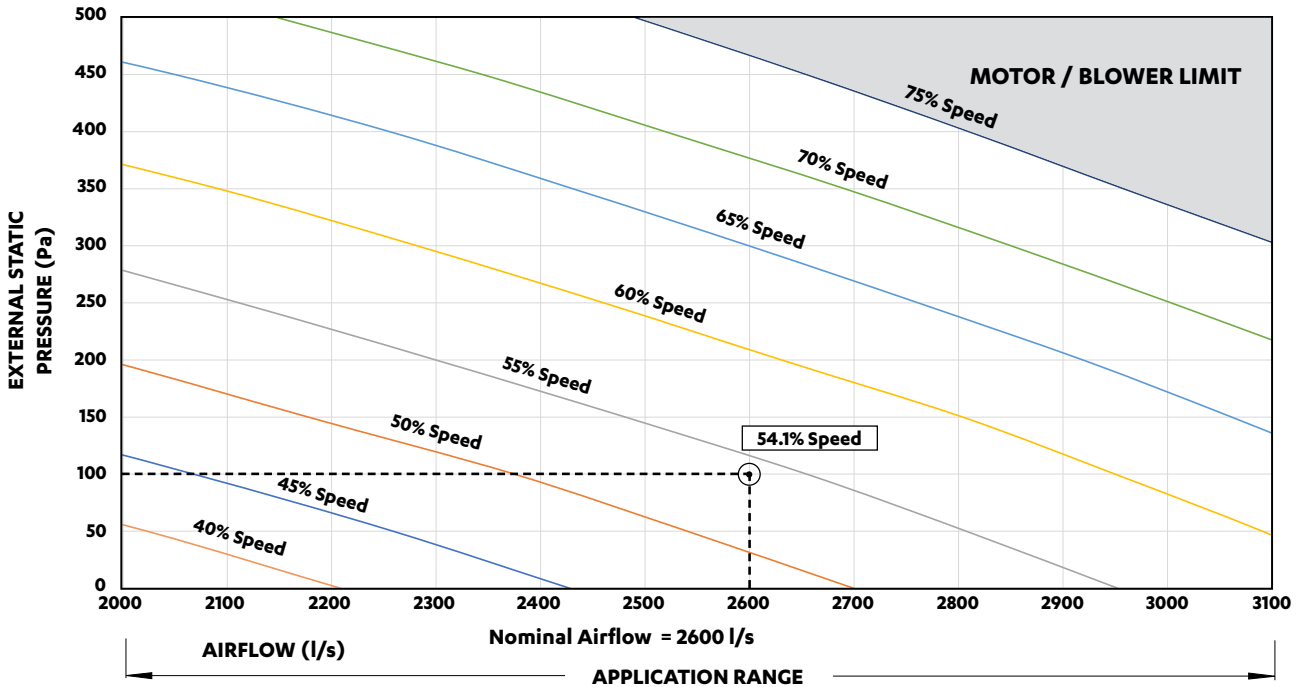

**NOTE**

Fan Performance Data and Fan Curve shown is at dry coil and with no air filters installed. Consider external static pressure drop specific to your design requirements. Airflow should be reduce with respect to the moisture content in the air. Please review filter manufacturer for application. 2.5 m/s face velocity point will occur at 3450 l/s.



## FAN PERFORMANCE DATA

PKY620T

Airflow (l/s)	External Static Pressure (Pa)																			
	50		100		150		200		250		300		350		400		450		500	
	% Spd.	W	% Spd.	W	% Spd.	W	% Spd.	W	% Spd.	W	% Spd.	W	% Spd.	W	% Spd.	W	% Spd.	W	% Spd.	W
2500	48.2	869	51.5	1030	56.1	1269	59.9	1505	63.8	1765	67.9	2028	72.0	2297	75.8	2579	78.8	2875	83.2	3310
2600	49.2	905	53.3	1107	57.5	1350	61.3	1596	65.3	1864	69.5	2134	73.5	2398	76.8	2683	79.6	2973	84.6	3490
2700	50.2	941	55.1	1188	58.9	1435	62.8	1694	66.9	1965	71.1	2239	75.0	2495	77.8	2792	81.1	3096	88.1	3550
2800	52.2	1023	56.6	1275	60.3	1523	64.3	1792	68.6	2073	72.6	2346	76.1	2627	78.9	2913	83.2	3235		
2900	54.1	1106	58.0	1357	61.9	1623	66.0	1900	70.4	2191	74.1	2468	77.2	2751	80.1	3032	85.5	3372		
3000	55.9	1196	59.5	1446	63.5	1725	67.8	2013	71.9	2303	75.4	2580	78.5	2869	82.6	3198				
3100	57.5	1284	61.2	1548	65.1	1830	69.7	2133	73.4	2406	76.9	2703	80.1	3001	84.8	3371				
3200	59.1	1368	62.9	1652	67.1	1945	71.4	2238	75.0	2509	78.4	2854	82.4	3192						
3300	60.9	1480	64.6	1764	69.2	2059	73.1	2355	76.6	2676	80.1	3044	84.8	3363						
3400	62.7	1594	66.8	1887	71.1	2184	74.8	2486	78.3	2850	82.4	3188								
3500	64.5	1708	68.9	2010	72.8	2315	76.4	2641	79.9	3009	85.0	3342								
3600	66.7	1837	70.9	2144	74.6	2452	78.1	2802	82.4	3155										
3700	69.0	1975	72.8	2277	76.4	2603	79.9	2961	85.0	3315										
3800	71.1	2107	74.8	2411	78.2	2769	82.5	3130												
3900	73.1	2244	76.6	2578	80.0	2952	85.4	3292												

**MOTOR / BLOWER LIMIT**

**NOTES:**

% Speed = Indoor Fan Speed Control Setting, in percent  
(Value is set on the Control Interface via Service Menu \*).

W = Indoor Fan Power, Watts

□ - Data in the box indicates Factory Default Setting.

\*Service → Service Settings → Thermoregulation → Thermoregulat. Gfc4

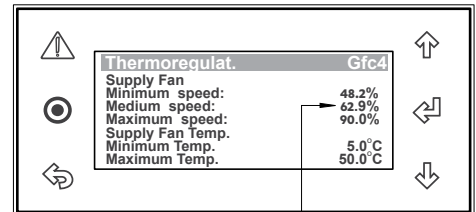

Set Fan Speed

## INDOOR UNIT FAN CURVE

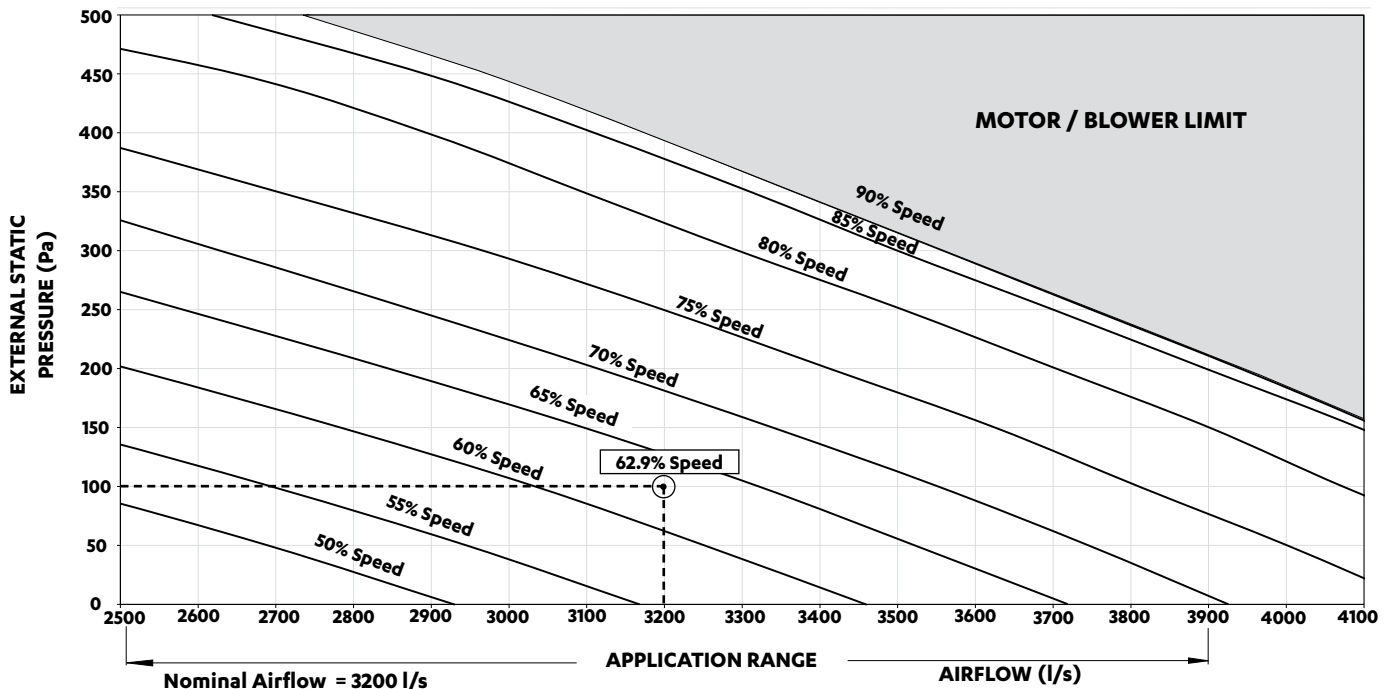

**NOTE**

Fan Performance Data and Fan Curve shown is at dry coil and with no air filters installed. Consider external static pressure drop specific to your design requirements. Airflow should be reduced with respect to the moisture content in the air. Please review filter manufacturer for application. 2.5 m/s face velocity point will occur at 4097 l/s.

## FAN PERFORMANCE DATA

PKY700T

Airflow (l/s)	External Static Pressure (Pa)																					
	50		100		150		200		250		300		350		400		450		500			
	% Spd.	W	% Spd.	W	% Spd.	W	% Spd.	W	% Spd.	W	% Spd.	W	% Spd.	W	% Spd.	W	% Spd.	W	% Spd.	W		
2800	52.2	341	56.6	425	60.3	507	64.3	597	68.6	691	72.6	782	76.1	876	78.9	971	83.2	1078				
2900	54.1	368	58.0	451	61.9	540	66.0	633	70.4	728	74.1	823	77.2	917	80.1	1011	85.5	1129				
3000	55.9	398	59.5	481	63.5	575	67.8	671	71.9	768	75.4	859	78.5	957	82.6	1066						
3100	57.5	428	61.2	516	65.1	611	69.7	710	73.4	802	76.9	902	80.1	1001	84.8	1124						
3200	59.1	456	62.9	551	67.1	648	71.4	746	75.0	837	78.4	951	82.4	1064								
3300	60.9	493	64.6	587	69.2	687	73.1	786	76.6	892	80.1	1015	84.8	1122								
3400	62.7	531	66.8	629	71.1	729	74.8	830	78.3	950	82.4	1063										
3500	64.5	580	68.9	670	72.8	772	76.4	881	79.9	1004	85.0	1113										
3600	66.7	612	<b>70.9</b>	<b>715</b>	74.6	817	78.1	934	82.4	1052												
3700	69.0	658	72.8	759	76.4	868	79.9	987	85.0	1106												
3800	71.1	702	74.8	804	78.2	924	82.5	1044														
3900	73.1	748	76.6	860	80.0	985	85.4	1103														
4000	75.0	793	78.5	917	82.8	1037																
4100	77.0	854	80.7	976	86.4	1089																

MOTOR / BLOWER LIMIT

### NOTES:

% Speed = Indoor Fan Speed Control Setting, in percent  
(Value is set on the Control Interface via Service Menu \*).

W = Indoor Fan Power, Watts

70.9 - Data in the box indicates Factory Default Setting.

\*Service → Service Settings → Thermoregulation → Thermoregulat. Gfc4

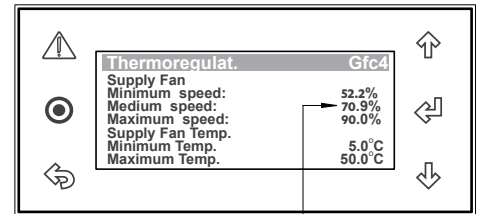

## INDOOR UNIT FAN CURVE

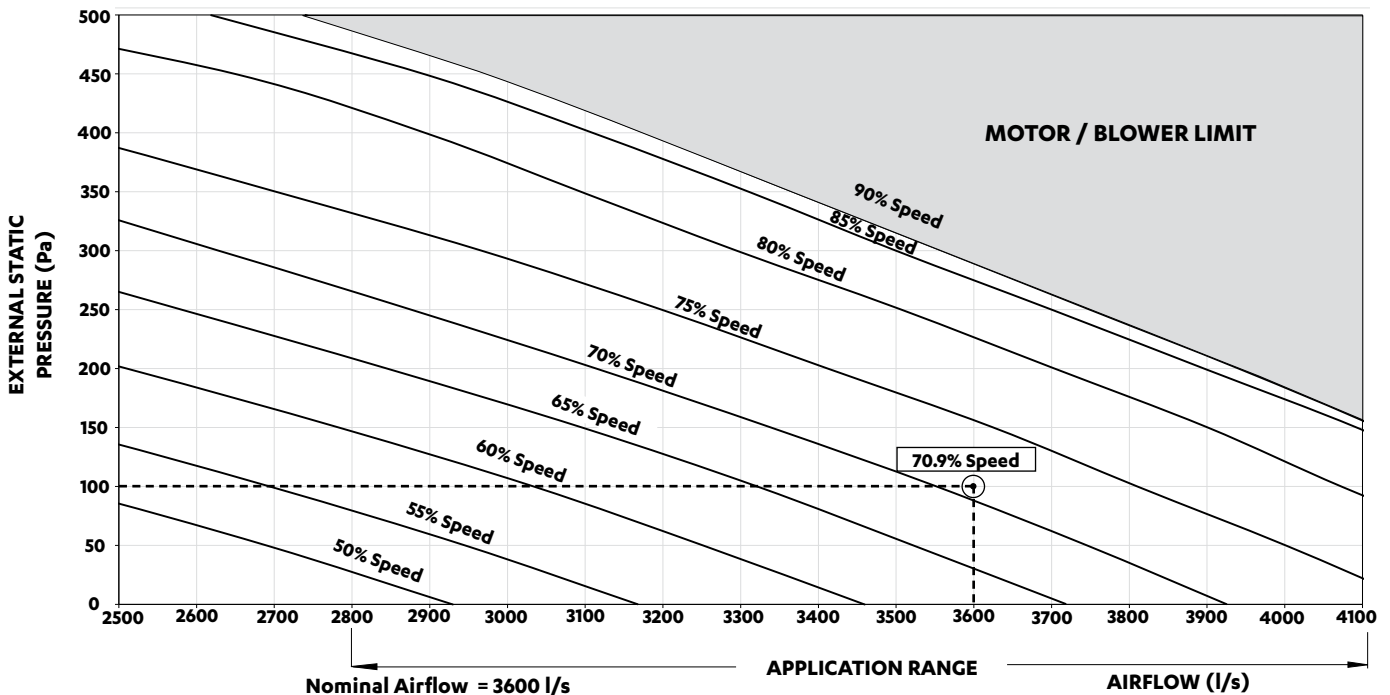

### NOTE

Fan Performance Data and Fan Curve shown is at dry coil and with no air filters installed. Consider external static pressure drop specific to your design requirements. Airflow should be reduced with respect to the moisture content in the air. Please review filter manufacturer for application. 2.5 m/s face velocity point will occur at 4097 l/s.

## 26. REFRIGERANT CHARGING

### NOTES

- The units detailed on this guide are pre-charged with R-410A refrigerant. Should there be need to add or remove some refrigerant, it is recommended to follow one of the charging methods explained below.
- The use of other material as a refrigerant other than R-410A may cause explosion and/or personal injury.
- Where crankcase heaters are in operation, ensure to power up the unit for a minimum of 3 hours prior to starting the compressor. For colder climates, a longer time period may be required.
- Never allow R-410A refrigerant to vent into the atmosphere. This is a serious offence in Australia and New Zealand. Always reclaim refrigerant using equipment and container dedicated for R-410A system use only.
- All work must be carried out in accordance with Australia and New Zealand refrigerant handling code of practice.
- Only qualified technicians must perform any work related to addition or removal of refrigerant.
- R-410A refrigerant must always be charged in liquid state. Always charge refrigerant in the unit liquid line. The air conditioning system should always be liquid charged from the cylinder. When the system is in a vacuum, always charge into the high pressure side. Although it is acceptable to charge refrigerant into the discharge service port, but the liquid line service port on the schrader valve is recommended.
- When the system is operating in cooling mode, it can be charge through the service port on the suction line ball valve (larger of the two schrader valves). This ensures the liquid refrigerant goes into the accumulator and then slowly enters the compressor.

### CAUTION

R-410A refrigerant has POE oil that rapidly absorbs moisture. The maximum time any system can be opened to atmosphere is 15 minutes.

### NOTE FOR SUBCOOLING AND SUPERHEAT ADJUSTMENT

This unit is designed with INTERLACED INDOOR HEAT EXCHANGER. Ensure that BOTH compressors are running in order to optimise the performance of the unit before reading discharge pressure and liquid line temperature. Then make the necessary refrigerant charge or Thermal Expansion Valve (TXV) adjustment when required. If only ONE compressor is running, the subcooling and superheat results will be different when compared with TWO compressors running.

REFRIGERANT CHARGE DETAILS				
Model		PKY500T	PKY620T	PKY700T
Refrigerant Type		R-410A	R-410A	R-410A
Refrigerant - Circuit #1	grams	6075	7200	8300
Refrigerant - Circuit #2	grams	10930	12700	12800

### 26.01. Charging Method 1: Subcooling and Superheat

#### Parameters:

**LLT** = Liquid Line Temperature

**SLT** = Suction Line Temperature

**SCT** = Saturated Condensing Temperature

**SST** = Saturated Suction Temperature

#### Cooling Operation:

Subcooling should be between 4K and 8K.

#### Heating Operation:

Subcooling should be between 8K and 14K.

Superheat should be between 2K and 8K.

Superheat should be between 2K and 8K.

## 26.01.01. Cooling and Heating Operation:

Adjust the refrigerant charge to obtain the correct superheat and subcooling for optimal performance as follows:

1. Ensure that air filters are fitted to indoor unit and total system airflows are balanced. (Air filters are not supplied with the unit, it is the responsibility of the installing contractor to provide and fit adequate return air and fresh air filters).
2. Connect service gauges to the schrader valves. Two sets of R-410A service gauges are required, each one connected to circuit 1 and 2, in order to conduct simultaneous refrigerant charge adjustments.
3. Mount the temperature sensing devices (one for each circuit) on the liquid line as close as possible to the liquid and suction line service valve.

See Diagram Below

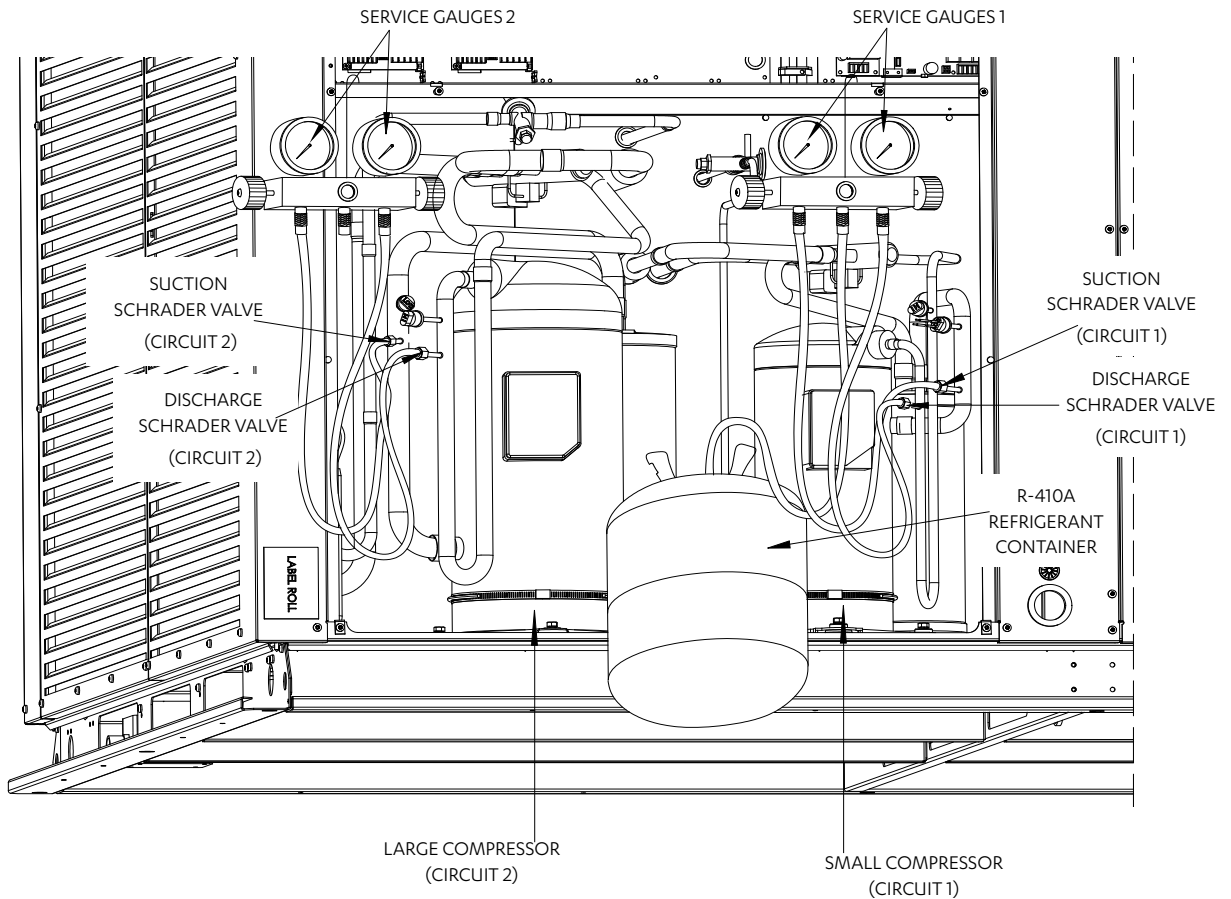

- Start the unit in cool mode ensuring that both circuit compressors are in 100% operation before taking service gauges reading. Allow the system to stabilize for next 20 minutes before recording.

Record the discharge pressure, suction pressure, liquid line temperature and suction line temperature for both systems.

Circuit 1 System (Small Compressor)

Discharge Pressure = \_\_\_\_\_ kPa

Suction Pressure = \_\_\_\_\_ kPa

Liquid Line Temperature (**LLT**) = \_\_\_\_\_ °C

Suction Line Temperature (**SLT**) = \_\_\_\_\_ °C

Circuit 2 System (Large Compressor)

Discharge Pressure = \_\_\_\_\_ kPa

Suction Pressure = \_\_\_\_\_ kPa

Liquid Line Temperature (**LLT**) = \_\_\_\_\_ °C

Suction Line Temperature (**SLT**) = \_\_\_\_\_ °C

## NOTES

Accurate pressure and temperature measuring tools should be used to achieve satisfactory results. The sensors of thermocouple must be in good contact with the area being measured and must be insulated in order to obtain correct reading.

### 26.01.02. Checking for Subcooling

- From the R-410A Pressure/Temperature Chart record the corresponding Saturated Condensing Temperature (**SCT**) at the given discharge pressure.
- Calculate the system subcooling using the formula below:

$$\text{Subcooling} = \text{SCT} - \text{LLT}$$

- If subcooling is within the range 4-8K, there is no need to add/remove refrigerant.
  - If subcooling is lower than 4K, the system is undercharged, it is necessary to add refrigerant.
  - If subcooling is higher than 8K, the system is over charged, it is necessary to remove refrigerant.

Allow the systems to stabilise and repeat the step 1-3 until subcooling falls within 4-8K.

### 26.01.03. Checking for Superheat

Maintaining the correct superheat is important for ensuring the evaporator is achieving maximum capacity and avoiding excessive liquid refrigerant returning to the compressor.

- From the R-410A Pressure/Temperature Chart record the corresponding Saturated Suction Temperature (**SST**) at the given suction pressure.
- Calculate the system superheat using the formula below:

$$\text{Superheat} = \text{SLT} - \text{SST}$$

- If superheat is within the range 2-8K, there is no need to add/remove refrigerant.
  - If superheat is lower than 2K, it means that liquid refrigerant may be returning to compressor. It is necessary to remove refrigerant or check TXV settings.
  - If superheat is higher than 8K, it means that refrigeration capability of evaporator is not fully maximised. It is necessary to add refrigerant charge or check TXV settings.

Allow the systems to stabilise and repeat the step 1-3 until superheat falls within 2-8K.

## NOTE

The above recommendations are based on design conditions of 35°C DB (outdoor), air entering indoor at 27°C DB /19°C WB (as per AS/NZS 3823.1.2).

**R-410A PRESSURE / TEMPERATURE CHART**

Temp °C	Pressure KPa
-60	-34.4
-59	-30.7
-58	-26.8
-57	-22.8
-56	-18.6
-55	-14.2
-54	-9.6
-53	-4.8
-52	0.8
-51	5.3
-50	10.7
-49	16.3
-48	22.2
-47	28.2
-46	34.0
-45	40.9
-44	47.8
-43	54.8
-42	62.1
-41	69.6
-40	77.4
-39	85.5
-38	93.9
-37	102.5
-36	111.5
-35	120.8
-34	130.4
-33	140.3
-32	150.5
-31	161.1
-30	171.9
-29	183.3

Temp °C	Pressure KPa
-28	194.9
-27	206.9
-26	219.2
-25	231.9
-24	245.1
-23	258.7
-22	272.6
-21	286.9
-20	301.7
-19	316.9
-18	332.6
-17	348.7
-16	365.2
-15	382.3
-14	399.7
-13	417.7
-12	436.2
-11	455.1
-10	474.6
-9	494.6
-8	515.1
-7	536.2
-6	557.8
-5	579.9
-4	602.6
-3	625.9
-2	649.8
-1	674.3
0	699.4
1	724.9
2	751.3
3	778.3

Temp °C	Pressure KPa
4	805.9
5	834.1
6	862.9
7	892.6
8	922.8
9	953.8
10	985.4
11	1017.8
12	1050.9
13	1084.7
14	1119.2
15	1154.6
16	1190.7
17	1227.5
18	1265.2
19	1303.6
20	1342.9
21	1382.9
22	1423.9
23	1465.7
24	1508.3
25	1551.8
26	1596.2
27	1641.4
28	1687.6
29	1734.6
30	1782.6
31	1831.6
32	1881.5
33	1932.3
34	1984.1
35	2036.9

Temp °C	Pressure KPa
36	2090.7
37	2145.5
38	2201.3
39	2258.2
40	2316.1
41	2375.1
42	2435.1
43	2496.2
44	2558.5
45	2621.8
46	2686.2
47	2751.8
48	2818.5
49	2886.4
50	2955.5
51	3025.7
52	3097.2
53	3169.9
54	3243.7
55	3318.9
56	3395.2
57	3472.9
58	3551.8
59	3631.9
60	3713.5
61	3796.3
62	3880.5
63	3965.9
64	4052.8
65	4140.9
66	4230.6
67	4321.5

## 26.02. Charging Method 2: Cooling Charging Curve

1. Start and run the unit in cool mode, ensuring that both circuit compressors are in 100% operation and systems stabilised for 20 minutes, record discharge pressure and liquid line temperature.
2. Plot the data in the cooling charging curve below.
3. If the plotted data point falls above the charging curve, it is necessary to remove refrigerant.
4. If the plotted data point falls below the charging curve, it is necessary to add refrigerant.
5. Repeat process 1-4 until the plotted data point falls along the curve.

### NOTES

Accurate pressure and temperature measuring tools should be used to achieve satisfactory results. The sensors of thermocouple must be in good contact with the area being measured and must be insulated in order to obtain correct reading.

### EXAMPLE:

Discharge Pressure = 3350 kPa

Liquid Line = 45°C

Action: Remove refrigerant charge from the system.

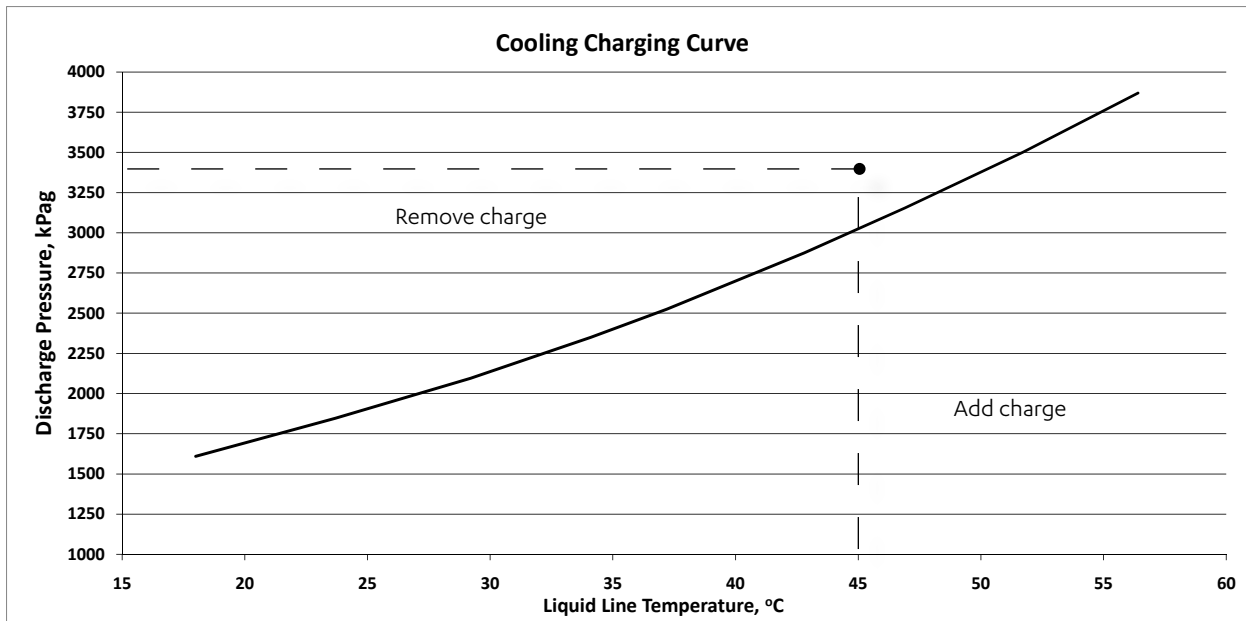

## 26.03. Thermal Expansion Valve (TXV) Adjustment

### ⚠ CAUTION

- Allow the systems to stabilise for 20 minutes before adjusting the thermal expansion valve (TXV) in order to ensure correct subcooling and superheat conditions. Turn Superheat Adjustment spindle 1/4 turn at a time, stabilising the systems in between adjustment, check condition, adjust again if necessary until correct subcooling and superheat conditions are attained.
- Thermal Expansion Valves are provided:  
1 x TXV for Small Compressor (Crt. 1) + 1 x TXV for Large Compressor (Crt. 2)

### Subcooling Adjustment

(Refer Subcooling Adjustment to Refrigerant Charging Section).

### Superheat Adjustment

If superheat is lower than 2k = turn Adjustment Spindle  $\frac{1}{4}$ <sup>+</sup>, stabilise system for 20 minutes, adjust if required.

If superheat is higher than 8k = turn Adjustment Spindle  $\frac{1}{4}$ <sup>-</sup>, stabilise system for 20 minutes, adjust if required.

See Diagram Below:

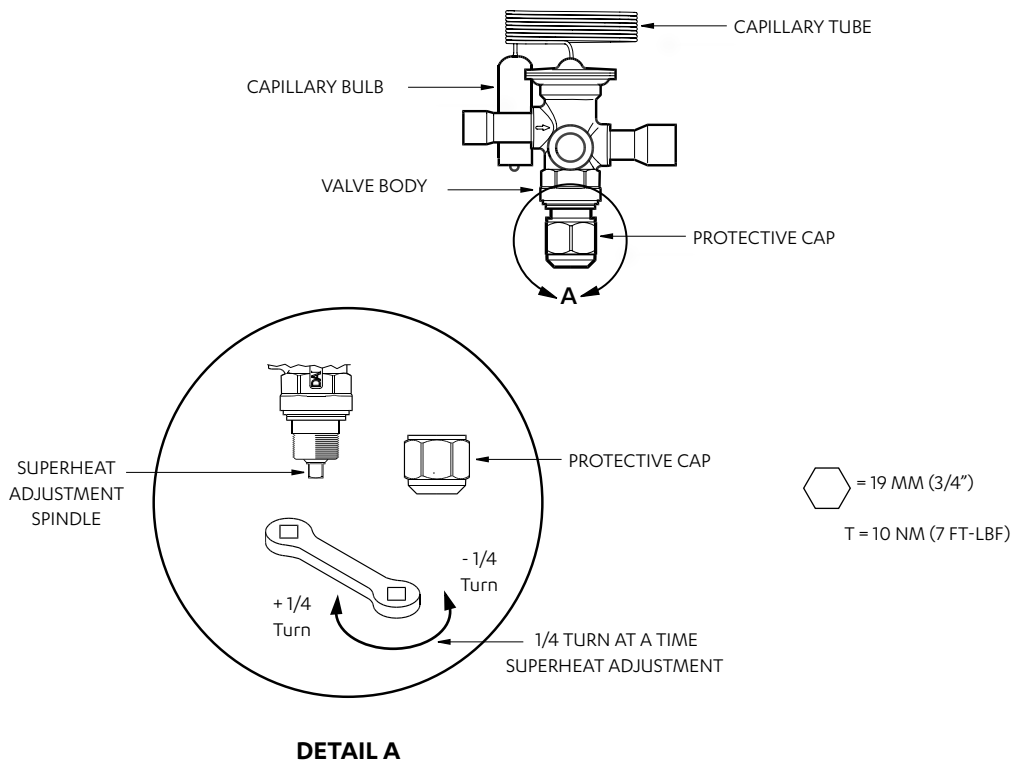



## 27. FAULT DISPLAY CODES

### 27.01. Control Fault Code Displays

**NOTES**

Codes shown below are only applicable to CP05 and CP10. Refer to the Owner’s Manual of CL01 and CL01-2 for fault display codes.

Description	Display Code	Type	Alarm Condition	Reset Condition
Out coil temp 1 faulty or wiring open/ short circuit (input U6)	AL08	Alarm	Outdoor Temperature 1 out of Range	Normal Operating Temperature
Out coil temp 2 faulty or wiring open/ short circuit (input U6)	AL10	Alarm	Outdoor Temperature 2 out of Range	Normal Operating Temperature
Room Air temp faulty or wiring open/ short circuit (input U9)	AL11	Alarm	Room Temperature Sensor faulty	Normal Operating Temperature
Outside Air temp faulty or wiring open/ short circuit (input U10)	AL12	Alarm	Outside Air Temperature Sensor faulty	Normal Operating Temperature
Compressor 1 Low Pressure Fault	AL15	Alarm	Ps < 165kPa	Ps > 330kPa
Compressor 2 Low Pressure Fault	AL16	Alarm	Ps < 165kPa	Ps > 330kPa
Compressor 1 High Pressure Fault	AL19	Alarm	Pd > 4500kPa	Pd < 3506kPa
Compressor 2 High Pressure Fault	AL20	Alarm	Pd > 4500kPa	Pd < 3506kPa
Compressor 1 High temperature Alarm	AL42	Alarm	Compressor 1 discharge high fault Discharge Temp > 120°C	Discharge Temp < 100°C
Compressor 2 High temperature Alarm	AL43	Alarm	Compressor 2 discharge high fault Discharge Temp > 120°C	Discharge Temp < 100°C
CO <sub>2</sub> Sensor Fault	AL48	Alarm	CO <sub>2</sub> sensor reading out of range	Normal operating CO <sub>2</sub> reading
Indoor Fan Anti -freeze Action	AL59	Warning	Temperature out of Range	Normal Operating Temperature
Service Reminder Please Clean the Indoor Fan air filter	AL200	Warning	Air Filter Timer Timed-Out Filter warning	Clean/Replace Filter and Reset Timer

**27.02. Soft Starter Display Codes**

<b>Operation Mode</b>	<b>On-Board LED Indication</b>
At first power Up	One per second for 10 seconds
Ready to Start	LED Off
Compressor Running	LED remains Off
Delay After Compressor Stop	One Blink per second for 50 secs, then LED Off

<b>Fault Operation</b>	<b>On-Board LED Indication</b>
Phase L1 Missing	LED Off (No Lights and No Compressor Operation)
Compressor Winding Open	4 Blinks (in burst) for 50 secs, then Compressor tries to start again.
Incorrect Phase Rotation	3 Blinks (in burst), Compressor will not try to start
Phase Lost or Low Voltage (less 200 V)	3 Blinks (in burst), Compressor will not try to start
Compressor Winding Swapped	LED Off (Compressor runs noisy - clacking sound)
Compressor Failed to Start	2 Blinks for 4 minutes

**NOTE**

As soon as the error condition goes away, the board logic will remove the error code.

## 28. MAINTENANCE

### Maintenance Procedures

This section describes the procedures that must be performed as a part of normal maintenance program. Regular servicing of equipment by licensed technician is highly recommended. Regular servicing of your unit helps in maintaining its optimum performance and reliability. **The checklist and service periods provided on this manual are guides only, as some sites may require more frequent servicing.** Always disconnect electrical power to the unit before performing these procedures. It is always a safe practice to observe all safety warnings and cautions when conducting maintenance tasks.



#### DANGER

##### Live Electrical Connections!

It may be necessary to work with live electrical components on certain maintenance tasks. Only licensed electricians and qualified technicians are allowed to perform these tasks.



#### CAUTION

##### Beware of Rotating Fan Blades!

Always make sure that all power supply, to the Outdoor Fans are turn Off and isolated.

Observe WH&S safety procedures, do not wear loose clothing and any jewellery when working near the fans.

Wear PPE whenever performing any maintenance procedures.

Observe all necessary procedures when working on a confined space.



#### WARNING

##### Hazardous Voltage !

Always make sure that all power supply, including remote controls, are disconnected before performing maintenance.

Observe proper LOCK-OUT/TAG-OUT procedures to ensure that power cannot be inadvertently energised. Failure to disconnect power before maintenance procedures can result in serious injury and/or death.

EC Motors are fitted with high power capacitors and can have dangerous residual voltages at motor terminals after power has been isolated. Wait at least 5 minutes after power isolation and test for any residual voltage before beginning service work.

### Annual Maintenance Checklists

- Perform general maintenance inspections.
- Perform scheduled start-up checks.
- Leak test refrigerant circuits.
- Inspect contacts of all contactors and relays. Replace all worn contacts as required.
- Inspect, clean and tighten all electrical connections.
- Check fans for balanced operation. Make sure that there are no loose screws/bolts, no fan blades interference and no damage to the fans and guards.
- Inspect the air filters, clean or replace as required.
- Clean and repaint any corroded panel section.
- Ensure no blockage of airflow through variable speed drive.

### Cleaning the Condenser Coils

Clean the coils at least once a year or more frequently if unit is located in a dusty and dirty environment, in order to maintain your system's proper operating performance. High discharge pressures are good indication that the coils need cleaning. When using detergent or solvents to clean the coils, follow the manufacturer's instructions to avoid potential damage to the coils and to the unit.

To clean the refrigerant coils, use a soft brush and water spray, such as garden hose or pressure washer with low pressure nozzle.



#### **WARNING**

##### **Do Not Use High Alkaline Detergent!**

When using detergent for coil cleaning, ensure that the alkaline level is no higher than 8.5, which can cause corrosion damage to the coils.



#### **DANGER**

##### **No Water into the Electrical Compartments!**

Ensure consideration is given to the possibility of water entering the electrical compartments during cleaning of the condenser coil.

### Coil Cleaning Procedures

- Disconnect power to the unit.
- Remove the louvered panels from the unit to gain access to the air inlet side of the coils.
- Use a soft brush to remove loose dirt and debris from both sides of the coils.
- Straighten bent coil fins with fin comb.
- Prepare the detergent solutions according to the manufacturer's instructions.
- Spray solution at a 90° angle to the coils, keeping a minimum nozzle spray angle of 15°, with at least a 1800mm distance from the coils and 600 psi pressure.
- Spray leaving air side of the coils first then the air inlet side. Allow the solution to stand on the coils for five minutes.
- Rinse both sides of the coils with cool clean water.
- Inspect the coils, if they are still dirty, repeat the cleaning procedure.
- Clean and wipe dry the outer and inner sides of the unit, the refrigerating parts and other components.
- Ensure that the condensate drain lines are not blocked.
- Reinstall all unit panels, covers and guards.
- Restore electrical power to the unit.

## 29. MAINTENANCE FREQUENCY CHECKLIST

ELECTRICAL											
Parts	Service Period					Detail of Service Check	Service Methods				
	1 Mth	3 Mth	6 Mth	1 Yr	2 Yrs			3 Yrs	4 Yrs	5 Yrs	
Isolators/Printed Circuit Boards			✓							Visual Inspection	Tighten Terminals as necessary on isolators and printed circuit boards.
Electrical Connections			✓							Check all electrical terminals, mains, communications, etc.	Re-tighten if loose.
Magnetic Contactor			✓							Check for loose terminal connections.	Tighten electrical terminals. Remove any dust.

INDOOR SECTION											
Parts	Service Period					Detail of Service Check	Service Methods				
	1 Mth	3 Mth	6 Mth	1 Yr	2 Yrs			3 Yrs	4 Yrs	5 Yrs	
Casing/Panels and Frames		✓								Visual check for damage, rust and dust accumulation.	For highly corrosive environment, wash panels quarterly with water and neutral detergent solution. Wax panels. Repair/re-paint where required.
Insulation					✓					Visual check for insulation conditions.	Repair/replace insulation material.
Fan			✓							Visual check for run out of balance and dust attached.	Clean off dust as necessary to negate possibility of fan running out of balance.
Motor				✓	Ω					Visual check on wiring. Insulation resistance check to be carried out annually.	Measure insulation resistance. Should be more than 1MΩ.
Heat Exchanger			✓							Check for clogging by dust. Check for leaks/damage.	Clean air inlet side as necessary. Straighten any bent fins using fins comb.
Drain Pan/Condensation line		✓								Check for obstructions and free flow of water.	Clean to eliminate obstructions/sludge and check condition of pan. Pour water to ensure flow.
Filter*	✓									Check for clogging by dust.	Clean Filter.
Temperature Readings		✓								Measure air on and air off.	Place temperature probe in return and supply air of the unit.
Damper Motors (If fitted)			✓							Visual inspection of motors open/closing. Ensure no obstructions.	Drive motors opened and closed. Ensure correct operation.

\*Service period for filter cleaning may vary depending on operating time and surrounding environment.

OUTDOOR SECTION										
Parts	Service Period								Detail of Service Check	Service Methods
	1 Mth	3 Mth	6 Mth	1 Yr	2 Yrs	3 Yrs	4 Yrs	5 Yrs		
Casing/Panels and Frames		✓							Visual check for damage, rust and dust accumulation.	For highly corrosive environment, wash panels quarterly with water and neutral detergent solution. Wax panels. Repair/re-paint where required.
Insulation					✓				Visual check for insulation conditions.	Repair/replace insulation material.
Fan			✓						Visual check for run out of balance and dust attached.	Clean off dust as necessary to negate possibility of fan running out of balance.
Motor				✓ Ω					Visual check on wiring. Insulation resistance check to be carried out annually.	Measure insulation resistance. Should be more than 1MΩ.
Heat Exchanger			✓						Check for clogging by dust. Check for leaks/damage.	Clean air inlet side as necessary. Straighten any bent fins using fins comb.
Condensate Drain Line		✓							Check for obstructions and free flow of water.	Clean to eliminate obstructions/sludge and check condition of drain line. Pour water to ensure flow.
Compressor		✓ Ω							Check for high/low pressure. Measure insulation resistance. Check compressor for abnormal noise/vibrations.	Measure insulation resistance. Should be more than 1MΩ.
Refrigeration Operational Readings		✓							Make note of operational reading in test cool/heat.	Check operating pressures, record super heat and sub-cool values.
Safety Devices			✓						Check calibration of safety devices such as HP and LP controls, sensors, etc.	Check resistance of sensors, pressure cut in/cut out of pressure controls.
Faults		✓							Check for any previous fault history on the unit.	Investigate any causes for previous faults, reset fault history.
Outdoor Fan Speed Capacitor				✓					Check for any bulge on the capacitors and capacitance.	Make it electrically safe, prior to measuring the capacitor's capacitance. Measured capacitance should be within the printed tolerances on the capacitor.

### 30. SENSOR DETAIL

<b>TEMPERATURE SENSORS</b>		
<b>Description</b>	<b>Location</b>	<b>ActronAir Part Number</b>
Compressor 1 Discharge Temp. Sensor	Compressor 1 Discharge line	2060-018
Compressor 2 Discharge Temp. Sensor	Compressor 2 Discharge line	2060-018
Outdoor Coil 1 Temperature Sensor	Last return bend of Coil system 1	2060-006
Outdoor Coil 2 Temperature Sensor	Last Return Bend of Coil system 2	2060-026
Room Air Temperature Sensor	Packed together with Installation and Commissioning Guide	2060-036
Ambient Air Temperature Sensor	Outdoor Coil System 2 Air Inlet side	2060-036
Indoor Coil Temperature Sensor	Indoor Coil - Model dependent	2060-026

<b>SWITCHES</b>			
<b>Description</b>	<b>Location</b>	<b>Type</b>	<b>ActronAir Part Number</b>
Compressor 1 High Pressure Switch	Compressor 1 Discharge Line	Pressure Switch	2060-019
Compressor 2 High Pressure Switch	Compressor 2 Discharge Line	Pressure Switch	2060-019
Compressor 1 Low Pressure Switch	Compressor 1 Suction Line	Pressure Switch	2060-020
Compressor 2 Low Pressure Switch	Compressor 2 Suction Line	Pressure Switch	2060-020

### 31. START-UP AND COMMISSIONING REPORT

**Completing Settings Log Procedures**

1. Switch-Off all motor start circuit breakers (MSCB), leaving circuit breakers CB1, CB2 and CB3 Switched-On.
2. Fill-in all current settings and information in SETTINGS LOG below:

**Settings Log:**

**NOTE**

Please log all required information below, before any software changes are to be made. Failure to do so will cause difficulties in restarting the unit operation back to original settings. Leave this manual in a secure location near the unit.

**INSTALLATION INFORMATION**

CUSTOMER	Name:	Tel. No.
	Address:	
INSTALLER	Name:	Tel. No.
	Address:	
SITE ADDRESS:		Date Installed:
MODEL:		Serial Number:

**B1**

**Setpoint**

Setpoint: \_\_\_\_\_ °C

Temp. Setback:  Enabled  Disabled

Cooling Limit: \_\_\_\_\_ °C Heating Limit: \_\_\_\_\_ °C

**Indoor Fan Settings**

% ID Fan Speed \_\_\_\_\_ %

**D1**

Enable Scheduler  No  Yes

**C1**

**Mode Of Operation**

Mode:  Auto  Cool Only  Heat Only

Indoor Fan Mode:  Continuous  Auto Cycle

**D2**

DST  Enable  Disable

Transition Time: \_\_\_\_\_ min.

Start: \_\_\_\_\_ in \_\_\_\_\_ at \_\_\_\_\_ End: \_\_\_\_\_ in \_\_\_\_\_ at \_\_\_\_\_

**D3 - D7**

**TIMECLOCK SETTINGS**

	Event 1	Event 2
<sup>(1)</sup> Monday	_____ to _____	_____ to _____
<sup>(1)</sup> Tuesday	_____ to _____	_____ to _____
<sup>(1)</sup> Wednesday	_____ to _____	_____ to _____
<sup>(1)</sup> Thursday	_____ to _____	_____ to _____
<sup>(1)</sup> Friday	_____ to _____	_____ to _____
<sup>(1)</sup> Saturday	_____ to _____	_____ to _____
<sup>(1)</sup> Sunday	_____ to _____	_____ to _____
<sup>(1)</sup> After Hours Operation Duration:	_____ Hours	

**NOTE:** <sup>(1)</sup> Only visible when Enable Scheduler is set to **Yes**.

**D8-D19**

**SPECIAL DAYS SETTINGS**

	Day / Month	Event 1	Event 2		Day / Month	Event 1	Event 2
Day 1	_____	_____	_____	Day 7	_____	_____	_____
Day 2	_____	_____	_____	Day 8	_____	_____	_____
Day 3	_____	_____	_____	Day 8	_____	_____	_____
Day 4	_____	_____	_____	Day 10	_____	_____	_____
Day 5	_____	_____	_____	Day 11	_____	_____	_____
Day 6	_____	_____	_____	Day 12	_____	_____	_____



# Installation and Commissioning Guide

# Package Tri-Capacity

SYSTEM CONFIGURATIONS (To access this menu, please enter the Service password: 7378).

G. Service → e. Communicate config.

<b>Ge1</b>				
Address:	Protocol:	<input type="checkbox"/> MODBUS	<input type="checkbox"/> CAREL	<input type="checkbox"/> MODBUS EXT.
Speed:	<input type="checkbox"/> 19200	<input type="checkbox"/> 9600	<input type="checkbox"/> 4800	<input type="checkbox"/> 2400 <input type="checkbox"/> 1200

<b>Ge2</b>		
Enable the BMS to turn the unit On / Off:	<input type="checkbox"/> No	<input type="checkbox"/> Yes
On loss of Comms:	<input type="checkbox"/> Turn Off	<input type="checkbox"/> Turn On <input type="checkbox"/> Use timeclock

<b>Ge3</b>		
Enable DIN4 to turn the unit On / Off	<input type="checkbox"/> No	<input type="checkbox"/> Yes

G. Service → f. Service settings → a. Working hour set

<b>Gfa1</b>	
Indoor Filter:	hours
Filter Fault relay:	<input type="checkbox"/> Yes <input type="checkbox"/> No
Indoor Fan:	hours
Compressor:	hours

G. Service → f. Service settings → b. Probe Adjustment

<b>Gfb1</b>	
(Return Air Temperature) Room Temp cal :	°C

G. Service → f. Service settings → c. Thermoregulation

<b>Gfc1</b>	
Room Temperature Setpoint:	°C
Dead band:	°C
Cool Proportion band:	°C
Heat Proportion band:	°C
Integral Time:	second

<b>Gfc6</b>	
Setpoint Limit Min. by user:	°C
Setpoint Limit Max. by user:	°C
User Setpoint:	
User Mode Sel:	
Modelock timer:	second

<b>Gfc2</b>	
Room Temperature use INDOOR sensor	
After Hours :	SW and Temp. <input type="checkbox"/> SW Only <input type="checkbox"/>
Probe weight value :	
Room Temp.:	°C
Wall Cont Temp.:	°C
Control Value:	°C

<b>Gfc7</b>	
Enable Night Mode by Scheduler:	<input type="checkbox"/> No <input type="checkbox"/> Yes
Start Time:	
Finish Time:	
Max Cond fan Spd:	%
cct 2 max Spd:	%

<b>Gfc4</b>	
<b>Supply Fan</b>	
Minimum speed:	%
Medium speed:	%
Maximum speed:	%
<b>Supply Fan Temp.</b>	
Minimum temp.:	°C
Maximum temp.:	°C

<b>Gfc8</b>	
Multi Input 1	<input type="checkbox"/> No <input type="checkbox"/> Yes
SUPPLY AIR TEMP	<input type="checkbox"/> Probe Type
ECONOMY ENABLE	<input type="checkbox"/> NTC <input type="checkbox"/>
NIGHT MODE ENABLE	<input type="checkbox"/> 0-5V <input type="checkbox"/>
0-10V STAGE CONT	<input type="checkbox"/> ON/OFF <input type="checkbox"/>
0-10V IN FAN SPD	<input type="checkbox"/> 4-20mA <input type="checkbox"/>
VIEW ONLY INPUT	<input type="checkbox"/> 0-20mA <input type="checkbox"/>
CO <sub>2</sub> SENSOR	<input type="checkbox"/> 0-10V <input type="checkbox"/>
PHASE FAIL RELAY	<input type="checkbox"/>
Multi Input 2	<input type="checkbox"/> No <input type="checkbox"/> Yes
SUPPLY AIR TEMP	<input type="checkbox"/> Probe Type
ECONOMY ENABLE	<input type="checkbox"/> NTC <input type="checkbox"/>
NIGHT MODE ENABLE	<input type="checkbox"/> 0-5V <input type="checkbox"/>
0-10V STAGE CONT	<input type="checkbox"/> ON/OFF <input type="checkbox"/>
0-10V IN FAN SPD	<input type="checkbox"/> 4-20mA <input type="checkbox"/>
VIEW ONLY INPUT	<input type="checkbox"/> 0-20mA <input type="checkbox"/>
CO <sub>2</sub> SENSOR	<input type="checkbox"/> 0-10V <input type="checkbox"/>
PHASE FAIL RELAY	<input type="checkbox"/>

<b>Gfc5</b>		
Supply Fan Gen. 3:	<input type="checkbox"/> No <input type="checkbox"/> Yes	
Supply Fan Continuous:	<input type="checkbox"/> No <input type="checkbox"/> Yes	
Cycle on de-ice:	<input type="checkbox"/> No <input type="checkbox"/> Yes	
One Speed Fan:	<input type="checkbox"/> No <input type="checkbox"/> Yes	
Speed Fan:	<input type="checkbox"/> Low <input type="checkbox"/> Med <input type="checkbox"/> High	
Supply Fan Run-on:	second	
Heat Start Delay:	second	

G. Service → f. Service settings → c. Thermoregulation (Continuous)

<b>Gfc11</b>	
<b>Unit Control Mode</b>	
Internal Sensors:	<input type="checkbox"/>
Remote Terminal:	<input type="checkbox"/>
Remote Demand:	<input type="checkbox"/>
External Input:	<input type="checkbox"/>
Supply Fan Control:	
Select Wall Control:	

<b>Gfc12</b>	
Unit Series:	
Unit Model:	
Variations:	

<b>Gfc13</b>	
<b>Type of fans fitted</b>	
Supply:	
Outdoor:	
Outdoor Init Speed	
OF1:	OF23:
Econ. Cycle Fitted:	<input type="checkbox"/> Yes <input type="checkbox"/> No
Econ. Type:	

<b>Gfc15</b>	
<b>Room Temp / Humidity</b>	
Sensor fitted:	<input type="checkbox"/> Yes <sup>(2)</sup> <input type="checkbox"/> No
Use this sensor temp. instead of AI9:	<input type="checkbox"/> Yes <input type="checkbox"/> No

<b>Gfc16</b>	
<b>Outside Temp / Humidity</b>	
Sensor fitted:	<input type="checkbox"/> Yes <sup>(3)</sup> <input type="checkbox"/> No
Use this sensor temp. instead of AI10:	<input type="checkbox"/> Yes <input type="checkbox"/> No

<b>Gfc17</b>	
<b>Alarm Disable</b>	
Outdoor Unit	
RTN AIR Sensor:	<input type="checkbox"/> Yes <input type="checkbox"/> No

<b>Gfc18</b>	
<b>Alarm Disable:</b>	
Indoor Unit	
RTN AIR Sensor:	<input type="checkbox"/> Yes <input type="checkbox"/> No

<b>Gfc19</b>	
<b>Damper Scaling</b>	
Command Start:	%
Command End:	%
Output Start:	%
Output End:	%

<b>Gfc31 <sup>(1)</sup></b>			
<b>CO<sub>2</sub> Control</b>			
Start:	ppm	End:	ppm
Alarm Output:	<input type="checkbox"/> Enabled <input type="checkbox"/> Disable		
Sensor Fault:	< ppm	> ppm	

<sup>(1)</sup> will be visible when <sup>(4)</sup> is enabled.

<b>Gfc32</b>	
<b>Compressors</b>	
1st Stage Start:	%
Stop:	%
2nd Stage Start:	%
Stop:	%
3rd Stage Start:	%
Stop:	%

G. Service → f. Service settings → d. Economy Setting

<b>Gfd1</b>	
<b>Min Outside Air</b>	
CO <sub>2</sub> Sensor Disabled	Damper Position: %
CO <sub>2</sub> Sensor Enabled <sup>(4)</sup>	
CO <sub>2</sub> Level	ppm ppm
Damper Position	% %

<b>Gfd2</b>	
<b>Economy Cycle</b>	
Enabled:	<input type="checkbox"/> Yes <input type="checkbox"/> No
Temperature Difference:	C
Outside Air Minimum Limit	<input type="checkbox"/> Yes <input type="checkbox"/> No
Temperature:	C

<sup>(4)</sup> will be visible when <sup>(3)</sup> outside temp/humidity sensor is set to **Yes**.

<b>Gfd3</b>	
<b>Economy Cycle</b>	
Outside Air Max Limit	
Temperature:	<input type="checkbox"/> Yes <input type="checkbox"/> No °C
<sup>(5)</sup> Humidity:	<input type="checkbox"/> Yes <input type="checkbox"/> No %
<sup>(5)</sup> Enthalpy:	<input type="checkbox"/> Yes <input type="checkbox"/> No kJ/kg
<sup>(5)</sup> Moisture:	<input type="checkbox"/> Yes <input type="checkbox"/> No g/kg
<sup>(5)</sup> Dew Point:	<input type="checkbox"/> Yes <input type="checkbox"/> No °C

<b>Gfd4 <sup>(6)</sup></b>	
<b>Economy Cycle</b>	
Enthalpy	<input type="checkbox"/> Yes <input type="checkbox"/> No
Difference:	kJ/kg

<sup>(6)</sup> will be visible when <sup>(2)</sup> and <sup>(3)</sup> are set to **Yes**.

**THIS PAGE WAS INTENTIONALLY LEFT BLANK**



©Copyright 2021 Actron Engineering Pty Limited ABN 34 002767240. ®Registered Trade Marks of Actron Engineering Pty Limited.  
ActronAir is constantly seeking ways to improve the design of its products, therefore specifications are subject to change without notice.