

ADVANCE SPLIT DUCTED UNIT

Indoor R-32 Series

Installation and Commissioning Guide

Model Numbers

Single Fan Coil

EVV13AS
EVV15AS
EVV17AS

Split Fan-Coil*

EAA13AS / EFV13AS
EAA15AS / EFV15AS
EAA17AS / EFV17AS

* Split fan coil has a separate coil and fan.

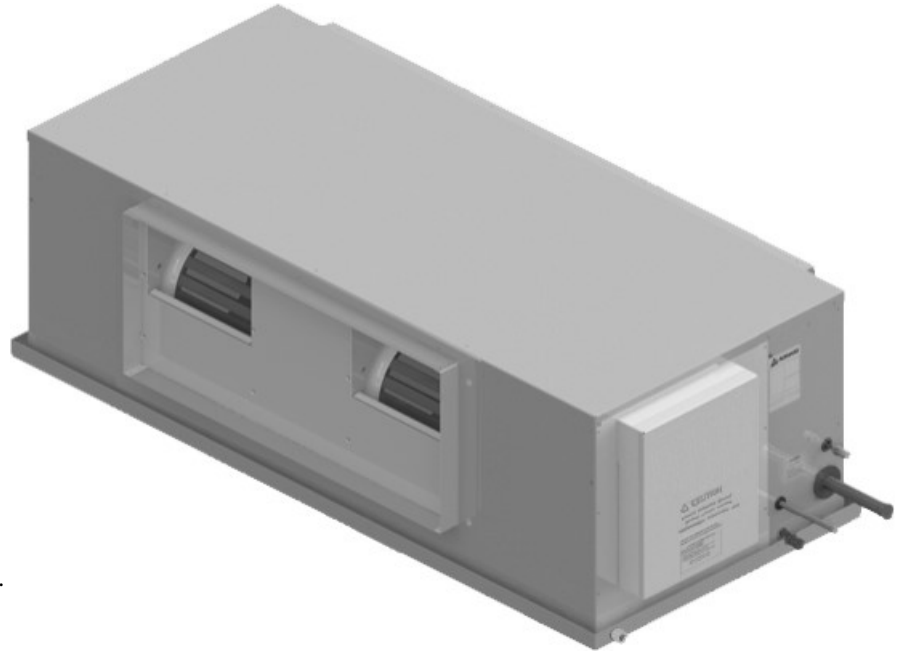

CAUTION:

The system is charged with flammable refrigerant, safety checks are necessary to ensure that the risk of ignition is minimised.

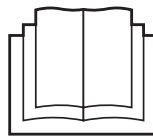

IMPORTANT NOTE:

This unit is designed for use with R-32 refrigerant only. Please read the R-32 Safety Manual and this manual carefully before installing or operating your air conditioning unit. Information in this manual is to be used in conjunction with the R-32 Safety Manual. Make sure to save this manual for future reference.

Table of Contents

Introduction	3
Safety Instructions	4
Components Overview	5
Indoor Unit Components Overview	5
Indoor Unit Electrical Panel Overview	5
Unit Dimensions and Clearances	6
Indoor Unit - EVV13AS / EVV15AS / EVV17AS	6
Two-Piece Fan Coil	8
Indoor Unit - Upright Fan Coil with Vertical Discharge	10
Minimum Service Areas and Airflow Clearances	11
Installation Instructions	12
Airflow Application Guidelines	14
Duct Static Pressure	14
Final and Return Air Duct Sizes	14
Return Air Grille Sizes	15
Other Guidelines	15
Unit Lifting Procedures	16
Crane Lifting Method	16
Fork Lift Method	17
Pallet Dimensions	18
Safety Drain Tray	19
Zone Barrel Installation Instructions	20
Electrical Installation	21
Wiring Diagram	22
Electrical Connection	23
Data Cable Shielding Instructions	24
Circuit Breaker Size and Cable Size Recommendation	25
Wall Controller Options	26
Wall Controller Options	26
Wiring Configuration : Recommended	27
Wiring Configuration : Alternate	28
Cable Length - Zoning	29
Neo Zone Controller / Neo Zone Sensor	29
LR7-1 / LR7-2	30
Wiring Connections	31
LR7-1 and LC7-2 Wall Control Wiring Connections	31
NEO Wall Control Wiring Connections	31
LM-RS-2 Optional Sensor Wiring Connections	32
AERSS Optional Duct Sensor Wiring Connections	32
Indoor Commissioning Guide	33
Zone Commissioning	34
Maintenance Frequency Checklist	35
Version History	36

Introduction

CONGRATULATIONS on your purchase of an ActronAir air conditioning system! This unit has been designed and engineered to provide optimum air conditioning and to achieve maximum energy efficiency.

Your air conditioning system has been manufactured from the highest quality materials. Numerous “in house” and “external” inspection and test procedures were conducted to your air conditioner to ensure satisfactory operation.

Information About This Guide

This guide provides installation instructions, specific to your ducted unit. Read this manual thoroughly and take into consideration all specifications and instructions to ensure correct installation and safe operation of your air conditioning system.

NOTE

Print a copy of this document and keep it for future reference. Ensure all technicians that work on the unit can refer to this manual at any time.

Product Inspections

Check your air conditioning unit and all items against the invoice upon receiving your shipment. Inspect the unit, components and accessories for any sign of damage. If there is any damage to the unit, contact ActronAir Customer Care Department immediately on: **1300 522 722** to obtain a Goods Return Number.

Check the unit nameplate to verify the model, serial number, electrical rated specifications are correct.

Codes, Regulations And Standards

The installer and/or contractor assumes responsibility to ensure that unit installation complies with the relevant council, state / federal codes, regulations and building code standards. All electrical wiring must be in accordance with current electrical authority regulations and all wiring connections to be as per electrical diagram provided with the unit

Important Safety Symbols And Labels

Safety Symbols and labels appear at appropriate sections throughout this manual to indicate immediate or potential hazards. Pay full attention and comply to the safety information and instructions. Failure to follow safety instructions increases the risks of personal injury, death and/or property damage. Damages to the product as a result of such failure may void warranty.

ActronAir has endeavoured to provide sufficient safety warnings and recommendations, however current and prevailing WH&S regulations must be observed and will take precedent whenever performing the installation instructions discussed in this manual.

Safety Instructions

- Only licensed HVAC technicians* should install and service air conditioning equipment. Improper service or alteration by an unqualified technician could result in significant and major damage to the product or property which may render your warranty null and void. Such unqualified service could also lead to severe physical injury or death. Follow all safety instructions in this literature and all warning labels that are attached to the equipment.
- Prevailing WH&S regulations must be observed and will take precedence to the safety instructions contained on this manual. Safe work practices and environment must be the paramount importance in the performance of all the service procedures.
- Ensure that unit installation complies with relevant council regulations and building code standards.
- All electrical wiring must be in accordance with current electrical authority regulations and all wiring connections to be as per electrical diagram provided.
- Secure the fans against accidental contact. Beware of pinch point and sharp edges which can cause cutting injury.
- Always wear appropriate PPE, remove any dangling jewelery and protect long hair by wearing a cap.
- Make sure that safety guards and panel covers are always firmly secured and not damaged before and during operation of unit.
- This appliance is not intended for use by young children or infirm persons unless they have been adequately supervised by a responsible person to ensure that they can use the appliance safely. Young children should be supervised to ensure that they do not play with the appliance.
- Installer must incorporate a means of electrical disconnection (isolator) in the sub mains fixed wiring in accordance with the latest edition of the AS/NZS 3000 (also known as Australian Wiring Rules).
- Secure the power cords and control cables that goes in/out the unit. Use the cable ties provided in the control box.
- This unit is designed for use with R-32 refrigerant only.

*Qualifications required will be appropriate Electrical, Refrigeration and Refrigerant Handling License and Training dependent on local State/Territory regulations.

DANGER

Hazardous Voltage - Risk of Electrocutation.

TURN-OFF the power from main isolator before proceeding with any service work of the unit. Observe proper LOCK-OUT/TAG-OUT (LOTO) procedures for electrical appliances in order to prevent accidental switching-on of the power supply.

WARNING

EC Motors and Compressor Drives are fitted with high power capacitors and can have dangerous residual voltages at motor/drive terminals after power has been isolated. Wait at least 5 minutes after power isolation and test for any residual voltage before beginning service work.

CAUTION

Beware of Rotating Fans !

Ensure that indoor and outdoor fans are isolated and have come to a complete stand still before servicing the equipment. Beware of pinch point and sharp edges which can cause cutting injury. Secure the fans against accidental contact. Always wear appropriate PPE and remove any dangling jewellery and protect long hair by wearing a cap. Ensure that no loose clothing can be caught / entangled in moving parts.

VISUAL INSPECTION AND WORK ASSESSMENT

Work areas and conditions must first be assessed and evaluated for any potential hazardous conditions. It is also important to be familiar with the unit parts and components before proceeding with any service task.

Components Overview

Indoor Unit Components Overview

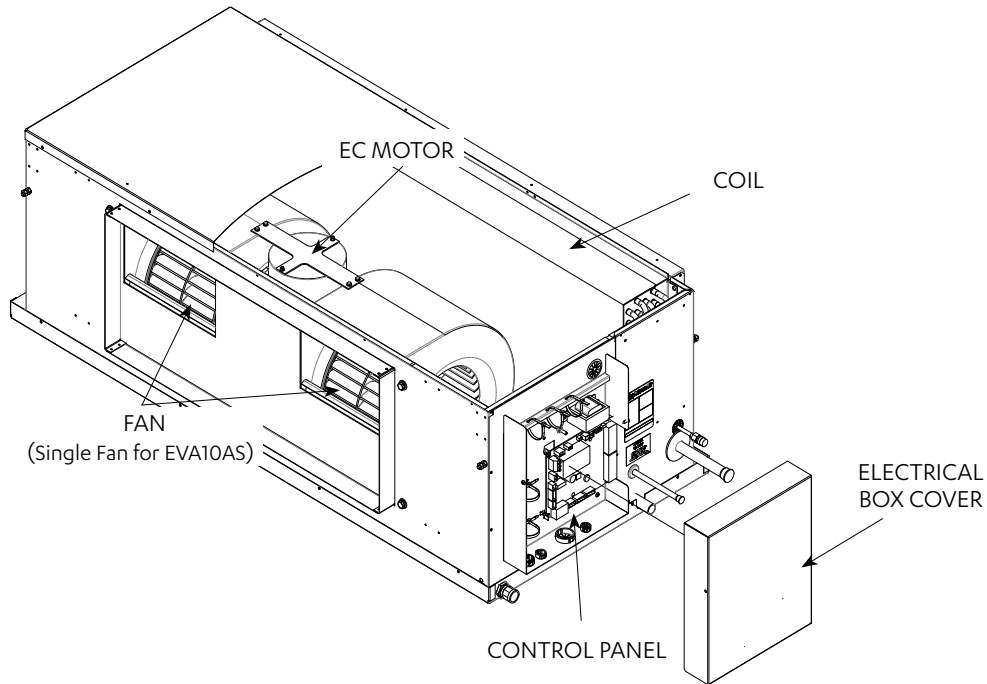

Indoor Unit Electrical Panel Overview

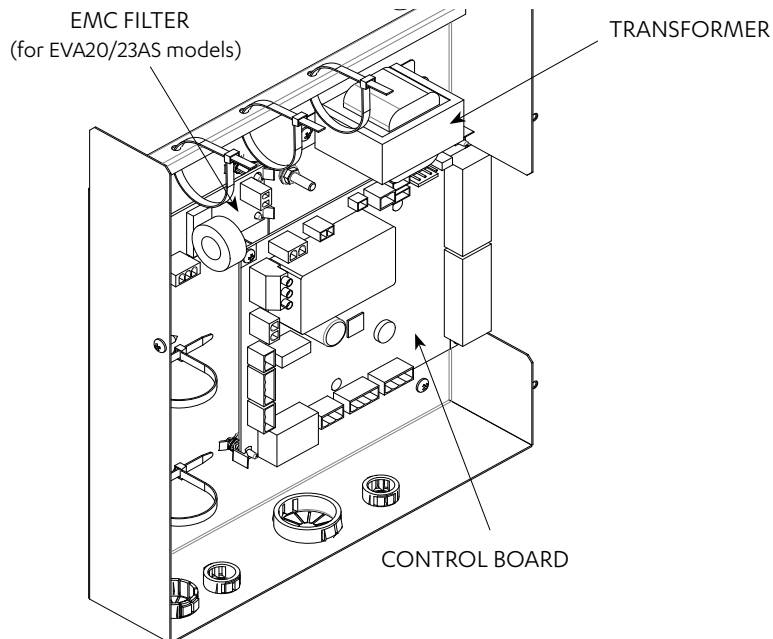

Unit Dimensions and Clearances

Indoor Unit - EVV13AS / EVV15AS / EVV17AS

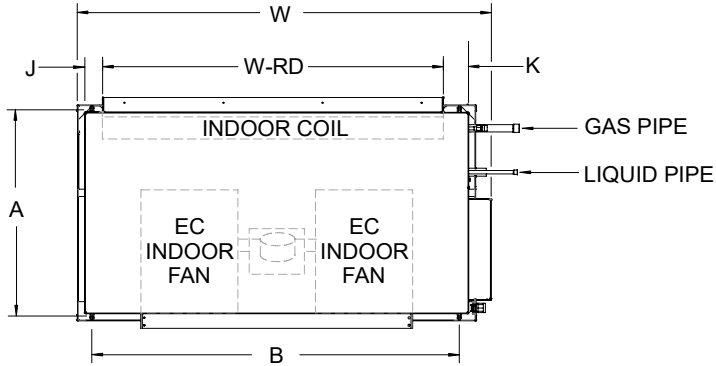

TOP VIEW

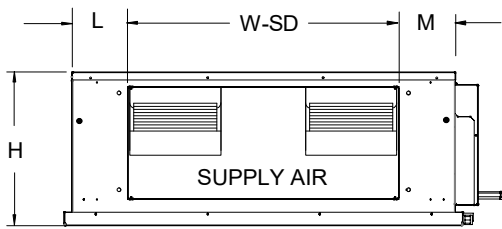

FRONT VIEW

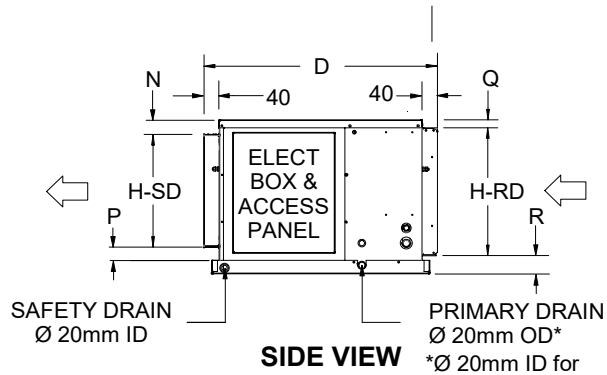

SIDE VIEW

NOTES:

Drawing is subject to change without notice. Image shown is for illustration purpose only. Actual unit may vary depending on unit model.

Unit Model Number	Overall Nominal Dimension (OA)			Mounting Distance Base Foot (Centre to Centre)		Supply Duct	Return Duct	Gas Pipe	Liquid Pipe
	H	W	D	A	B	H-SD x W-SD	H-RD x W-RD		
EVV13AS	412	1090	615	548	990	300 x 715	340 x 900	Ø 19.05mm (3/4") Swaged	Ø 9.52mm (3/8") Swaged
EVV15AS		1290			1190		340 x 1100		
EVV17AS	435	1420	680	603	1315		360 x 1140		

Unit Model Number	Dimensions							
	J	K	L	M	N	P	Q	R
EVV13AS	47	65	248.5	248.5	40	72	22	50
EVV15AS	47	65	248.5	248.5	40	72	22	50
EVV17AS	79	118	311	311	25	110	25	50

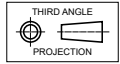
NOTES:

1. Do not scale drawing. All dimensions are in mm unless specified. Refer to corresponding unit dimensional drawing for mounting hole details.
2. Service Access Areas and Spaces for Airflow Clearances are suggested minimum based on the condition that the spaces around the units are free from any obstructions and a walkaway passage of 1000 mm between the units or between the unit and the outside perimeter is available.
3. Minimum service access areas and spaces for airflow clearances are responsibilities of the installer, ActronAir will not be held liable for any extra charges incurred due to lack of access and space for airflow.
 - Left Service Clearance can be 100mm minimum if Right Service Clearance is applicable.
 - Right Service Clearance can be 600mm minimum if Left Service Clearance is applicable.
 - Height Service Clearance can be 100mm minimum if Right Service Clearance is applicable.
4. Installation of this unit should be in accordance with AS/NZS 60335.2.40.
5. During installation ensure that the Minimum Floor Area of the smallest room is satisfied based on the Release height, or the maximum R-32 Charge amount is not exceeded.
6. Where a minimum area is not satisfied, the installer must provide additional control measure/s such as but not limited to ventilation, shut-off valves, and safety alarm in place as per AS/NZS 60335.2.40 standard for the installation to be acceptable. These control measures are not provided by ActronAir and must be determined by the installer based on individual installation requirements.
7. Refer to R-32 Safety Manual for further safety guides.

Two-Piece Fan Coil

Coil Section - EAA13AS / EAA15AS / EAA17AS

Note: EAA17AS model is shown for illustration purposes only.

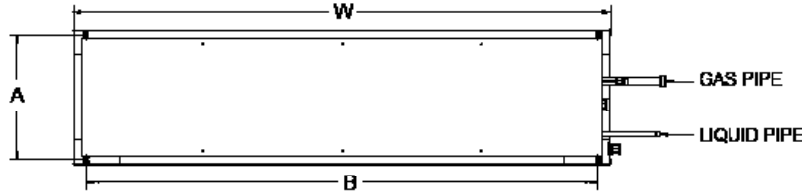

TOP VIEW



FRONT VIEW - SUPPLY AIR



REAR VIEW - RETURN AIR

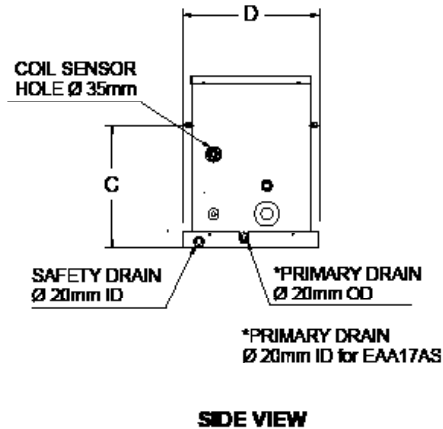

SIDE VIEW

without notice.
purpose only.
ing on unit

Unit Model Number	Overall Nominal Dimension (OA)			Mounting Distance Base Foot (Centre to Centre)			Supply Duct	Return Duct	Gas Pipe	Liquid Pipe
	H	W	D	A	B	C	H-SD x W-SD	H-RD x W-RD		
EAA13AS	410	1054	342	310	990	284	345 x 900	345 x 900	Ø 19.05mm (3/4") Swaged	Ø 9.52mm (3/8") Swaged
EAA15AS		1252			1190	283				
EAA17AS	435	1360			1294	310	362 x 1094	362 x 1094		

NOTES:

- Do not scale drawing. All dimensions are in mm unless specified. Refer to corresponding unit dimensional drawing for mounting hole details.
- Service Access Areas and Spaces for Airflow Clearances are suggested minimum based on the condition that the spaces around the units are free from any obstructions and a walkway passage of 1000 mm between the units or between the unit and the outside perimeter is available.
- Minimum service access areas and spaces for airflow clearances are responsibilities of the installer, ActronAir will not be held liable for any extra charges incurred due to lack of access and space for airflow.
 - Left Service Clearance can be 100mm minimum if Right Service Clearance is applicable.
 - Right Service Clearance can be 600mm minimum if Left Service Clearance is applicable.
 - Height Service Clearance can be 100mm minimum if Right Service Clearance is applicable.
- Installation of this unit should be in accordance with AS/NZS 60335.2.40.
- During installation ensure that the Minimum Floor Area of the smallest room is satisfied based on the Release height, or the maximum R-32 Charge amount is not exceeded.
- Where a minimum area is not satisfied, the installer must provide additional control measure/s such as but not limited to ventilation, shut-off valves, and safety alarm in place as per AS/NZS 60335.2.40 standard for the installation to be acceptable. These control measures are not provided by ActronAir and must be determined by the installer based on individual installation requirements.
- Refer to R-32 Safety Manual for further safety guides.

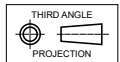

Fan Section - EFV13AS / EFV15AS / EFV17AS

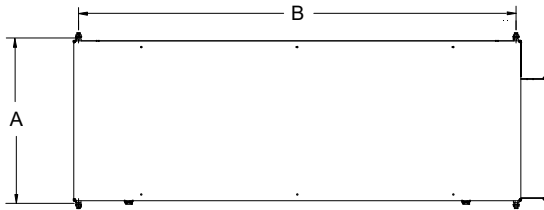

TOP VIEW

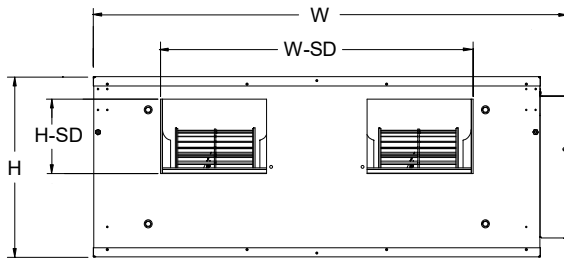

FRONT VIEW - SUPPLY AIR

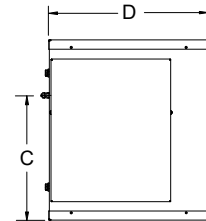

SIDE VIEW

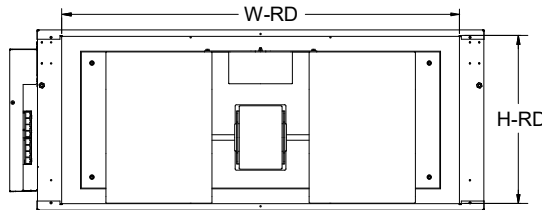

REAR VIEW - RETURN AIR

NOTES:

Drawing is subject to change without notice. Image shown is for illustration purpose only. Actual unit may vary depending on unit model.

Unit Model Number	Overall Nominal Dimension (OA)			Mounting Distance Base Foot (Centre to Centre)			Supply Duct	Return Duct
	H	W	D	A	B	C	H-SD x W-SD	H-RD x W-RD
EFV13AS	408	1072	362	370	990	282	186 x 708	378 x 900
EFV15AS								
EFV17AS								

NOTES:

- Do not scale drawing. All dimensions are in mm unless specified. Refer to corresponding unit dimensional drawing for mounting hole details.
- Service Access Areas and Spaces for Airflow Clearances are suggested minimum based on the condition that the spaces around the units are free from any obstructions and a walkway passage of 1000 mm between the units or between the unit and the outside perimeter is available.
- Minimum service access areas and spaces for airflow clearances are responsibilities of the installer, ActronAir will not be held liable for any extra charges incurred due to lack of access and space for airflow.
 - Left Service Clearance can be 100mm minimum if Right Service Clearance is applicable.
 - Right Service Clearance can be 600mm minimum if Left Service Clearance is applicable.
 - Height Service Clearance can be 100mm minimum if Right Service Clearance is applicable.
- Installation of this unit should be in accordance with AS/NZS 60335.2.40.
- During installation ensure that the Minimum Floor Area of the smallest room is satisfied based on the Release height, or the maximum R-32 Charge amount is not exceeded.
- Where a minimum area is not satisfied, the installer must provide additional control measure/s such as but not limited to ventilation, shut-off valves, and safety alarm in place as per AS/NZS 60335.2.40 standard for the installation to be acceptable. These control measures are not provided by ActronAir and must be determined by the installer based on individual installation requirements.
- Refer to R-32 Safety Manual for further safety guides.

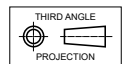

Indoor Unit - Upright Fan Coil with Vertical Discharge

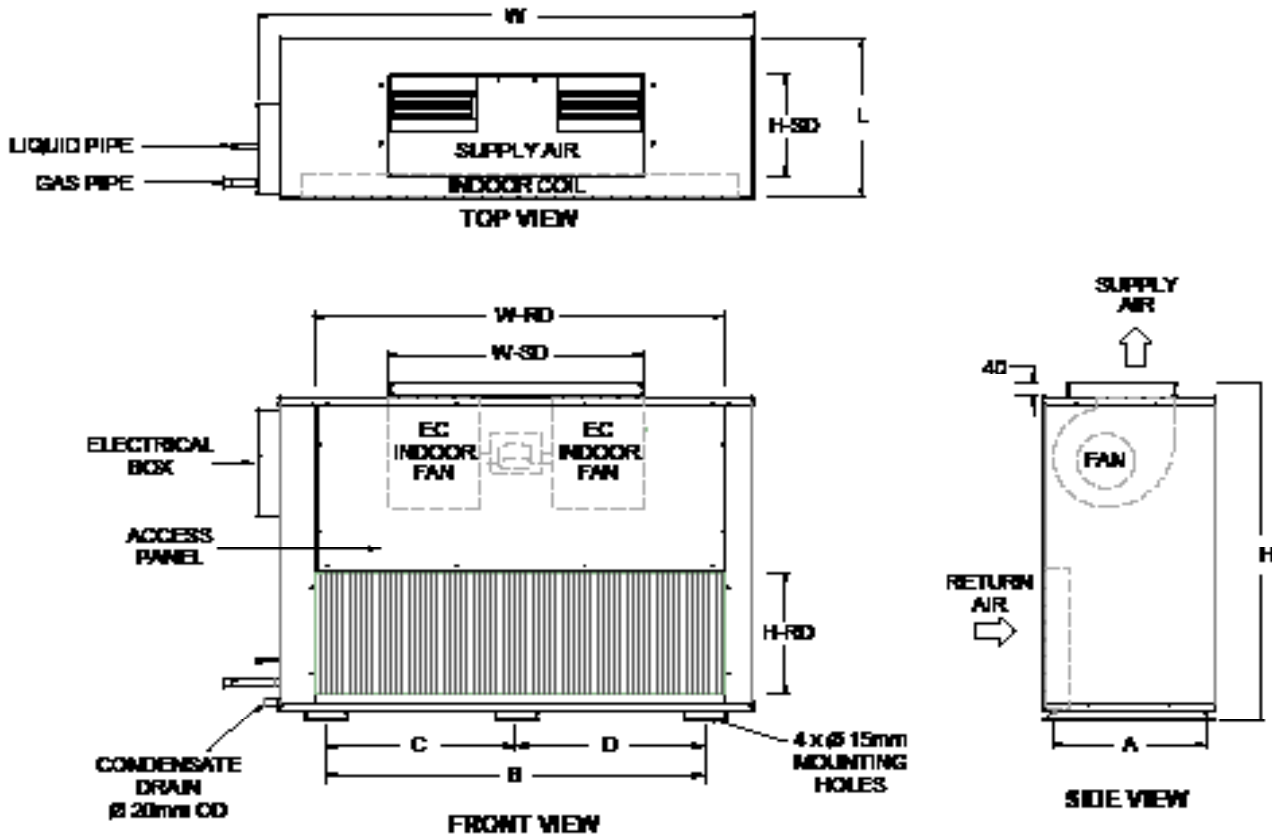

notice.
se only.
nit

Unit Model Number	Overall Nominal Dimension (OA)			Mounting Distance Base Foot (Centre to Centre)				Supply Duct	Return Duct	Gas Pipe (Swaged)	Liquid Pipe (Swaged)
	H	W	L	A	B	C	D	H-SD x W-SD	H-RD x W-RD		
EVV13AS-V	875	1075	405	350	790	-	-	300 x 715	365 x 895	Ø 19.05mm (3/4")	Ø 9.52mm (3/8")
EVV15AS-V		1275			990	-	-				
EVV17AS-V	1015	1390	480	430	-	530	530		365 x 1095		

NOTES:

- Do not scale drawing. All dimensions are in mm unless specified. Refer to corresponding unit dimensional drawing for mounting hole details.
- Minimum service access areas and spaces for airflow clearances are responsibilities of the installer, ActronAir will not be held liable for any extra charges incurred due to lack of access and space for airflow.
- For installation with release height less than or equal to 0.6m, minimum area will be computed based on release height of 0.6m
- Where A_{min} (the minimum area required) is not satisfied, the installer must provide additional control measure/s in place as per AS/NZS 60335.2.40 standard for the installation to be acceptable.
The examples of controls measures are (but are not limited to): Ventilation, Shut Off Valves and Safety Alarm. These control measures are not provided by ActronAir and must be determined by the installer based on individual installation requirements.
- Refer to R-32 Safety Manual for minimum required area and R-32 refrigerant of the installation.

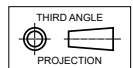

Minimum Service Areas and Airflow Clearances

Indoor Unit - EVV13AS / EVV15AS / EVV17AS

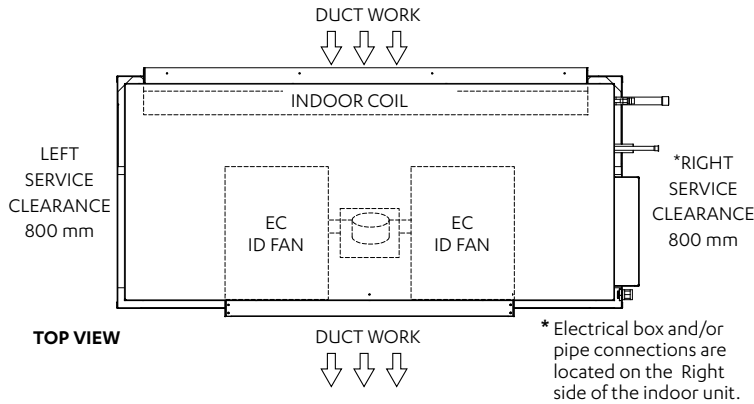

Coil Section - EAA13AS / EAA15AS / EAA17AS

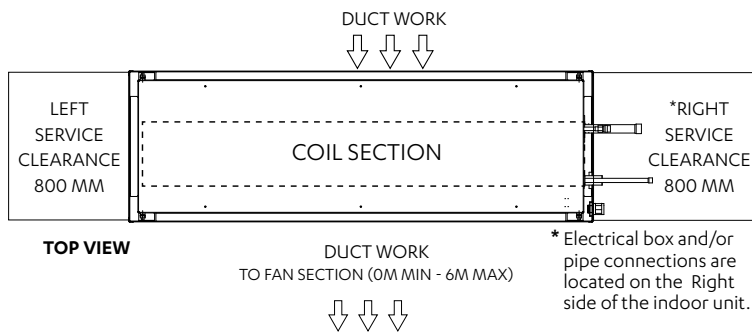

EFV13AS / EFV15AS / EFV17AS

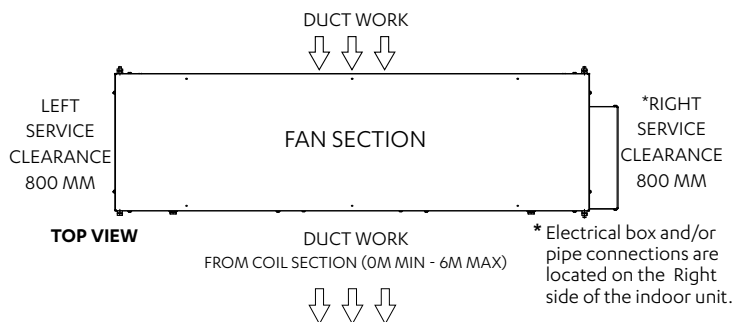

NOTES:

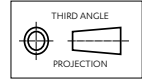

- Do not scale drawing.
All dimensions are in **mm** unless specified.
- Service Clearances given are suggested minimum based on the condition that the spaces around the units are free from any obstructions and a walkway passage of 1000mm between the units or between the unit and the outside perimeter is available.
- Minimum service access clearances are responsibilities of the installer, ActronAir will not be held liable for any extra charges incurred due to lack of access.
 - Left Service Clearance can be 100mm minimum if Right Service Clearance is applicable.
 - Right Service Clearance can be 600mm minimum if Left Service Clearance is applicable.
 - Height Service Clearance can be 100mm minimum if Right Service Clearance is applicable.

Model Number	Weight (kg)	Height Clearance
EVV13AS	44	340
EVV15AS	53	
EVV17AS	61	
EAA13AS	28.5	340
EAA15AS	37.5	
EAA17AS	45.5	
EFV13AS	35	340
EFV15AS	44	
EFV17AS	50.5	

Installation Instructions

The installation instructions provided below are intended as a guide only and does not supersede the relevant council, state and federal codes, regulations and building code standards. Compliance and consultation with the authorities having jurisdiction with the installation of this equipment is the responsibility of the installer. ActronAir will not be held liable for any damages or costs as a result of the installer's failure to comply. Please refer to the matching outdoor unit Installation and Commissioning Guide for further information and details.

Lifting The Unit

The installation instructions provided, in Unit Lifting Procedures, adhere to WH&S regulations for safe and secure lifting practices in order to prevent physical injury. The suggested lifting procedures are outlined as reference guide to safely lift and transport the unit, however, this does not over rule the industry WH&S practices.

Location

This unit is intended for indoor installation only. It is highly recommended that this indoor unit and accessories, particularly zone barrels, be mounted in the roof cavity.

Mount the unit in a stable and rigid support wherein the weight is properly distributed, such as roof joist and rafters. Take into consideration the minimum service access clearances provided in the unit drawings.

Locate the indoor unit away from the areas where noise is a critical factor. Use rubber mounting pad (not supplied) in order to minimize the transfer of noise and vibration into building structures.

An optional hanging bracket assembly and rubber grommet (supplied as standard with some models) is also available to secure the indoor unit into the roof rafters. This installation configuration is most suitable for installation that require the unit to be rigidly secured up from the roof joist.

NOTE

In locations where high humidity is expected, additional insulation shall be applied to the indoor unit.

Condensate and Safety Tray Drainage

An integrated safety drain tray is provided as a standard inclusion to your indoor unit in order to reduce the potential of condensate damage to the roof. Drain Kit (not included in some models) is provided for the condensate drain to be externally trapped from the indoor unit. Suggested condensate and safety tray drainage instructions are provided at the proceeding page for your reference.

NOTE

The included safety tray is provided for collection of internal condensation and for back up in case of main drain blockage. In locations where high humidity is expected, additional insulation or safety tray may be required to provide protection for externally formed condensation.

Supply Air and Return Air Duct

The indoor unit is supplied with duct flange as standard in order to facilitate the system's duct connection into the unit. Supply and return air duct works must be adequately sized to meet the system's air flow and static pressure requirements. Refer to the unit drawing for supply air and return air duct dimensions, specific to your requirement.

NOTES

In locations where high humidity is expected, ensure appropriate duct insulation level is considered for the environment. Inadequate insulation can result in condensation forming on the ductwork's surface, potentially leading to dripping condensation on the ceiling.

Ducted work should be adequately supported in order to prevent cold bridging.

Fit a flexible duct connection in between the unit and the duct system, where noise and vibration is a critical consideration.

Return Air Filter

Air filters must be provided in the return air side of the unit to maintain the efficiency and prolong the operation of the unit. These are also paramount to satisfy requirement for a clean and hygienic room condition. Return Air filters must be placed in an easily accessible location for service and maintenance.

NOTES

- Return Air filters are not supplied with the unit as individual air filtration requirements vary.
- Ensure that filters are cleaned / replaced regularly.

Air Plenums / Duct Plates (Optional)

Supply Air and Return Air plenums and duct plates (twin-spigot) are available as an option in order to facilitate your duct system connection to the indoor unit. The supply air plenums come in 1-way, 2-way and 3-way options, which offer a wider solutions to your different air distribution requirements.

NOTE

All exposed metal surfaces of the duct spigots should be adequately insulated when connecting ductwork to ensure performance and reduce the risk of condensation. All air gaps shall be appropriately sealed.

Split Fan Coil System (Optional)

The ActronAir innovative 2-piece fan coil system provides a solution to your difficult and tight roof space installation requirement. This versatile system has a separate fan and coil sections. Each of the compact and lightweight section is simply installed in two separate locations and joined by flexible duct system. Air ducts are attached to each section of the split fan coil by both of the supply air plenum and the twin spigot duct plate.

Fan Coil With Vertical Discharge (Optional)

An upright Fan Coil with vertical supply air discharge is also available wherein installation applications require the placement of the unit down in a closet, basement or garage. Please refer to the Technical Catalogue of your indoor unit for dimensions, installation details and specifications.

Field Pipe Connections

Specifications and installation requirements for field pipe connections are contained in the Installation and Commissioning Guide of the outdoor unit that matches your indoor unit. Please refer to this guide and thoroughly understand the procedures for safe and correct indoor and outdoor connection.

Field Electrical Connection

The power supply and control communication data to the indoor unit are supplied via the outdoor unit. Please refer to the wiring diagram supplied with the outdoor unit for specifications.

All electrical work must be performed by a licensed electrician and must conform with the wiring diagram and all relevant electrical authorities.

NOTES

This indoor unit is designed to match only with an ActronAir Series outdoor unit as specified in the Technical Selection Catalogue.

The unit is supplied with factory charged dry air. Be aware of the pressurised air charge when purging. Remove the caps from the connection points and purge the system only when the field pipe connections are ready to be completed.

Airflow Application Guidelines

ActronAir Active systems are designed and engineered to provide ideal air conditioning and to achieve maximum energy efficiency. It has a wide range of fan limit which allows customised three speed fan setting based on required airflow.

The following are some recommendations to make this system work to its optimum design.

Duct Static Pressure

The ideal system design is for a duct with a External Static pressure of 125Pa. This design static for the system allows for the optimal combination for duct sizing and energy efficiency of the system.

Final and Return Air Duct Sizes

There are set parameters for sizing and design of both final duct (from the last take off to the outlet) and return air duct and fittings. The following duct sizes are based on a maximum final duct air velocity of 3 m/s and a maximum return air velocity of 4 m/s.

Other Recommendations are:

- Main duct velocity is recommended to be within 6-7 m/s.
- Branch duct velocity is recommended to be within 4-6 m/s.

Model	Nominal Supply Air Flow (L/s)	Minimum Supply Air Flow (L/s)	Minimum Final Air Duct Sizes (mm)	Return Air Duct Sizes (mm)
EVV13AS / EFV13AS	650	230	1 x 300 or 2 x 250	2 x 350
EVV15AS / EFV15AS	770	260	1 x 300 or 2 x 250	2 x 400
EVV17AS / EFV17AS	890	300	1 x 350 or 2 x 250	2 x 400

NOTE

- Above values are designed to minimize noise generation at supply air outlet at minimum supply air flow.
- The above are the minimum requirements to maintain system unit operation and performance. Where minimum air flow requirement is not obtained errors and/or performance issues may arise.

To reduce noise issues at the supply air grilles, careful consideration must be taken when designing for minimum air quantity. As an example, based on table above, an EVV17AS / EFV17AS has a minimum supply air quantity of 300 l/s, this is too much airflow for 1 x outlet to handle and in this instance 2 x outlets correctly sized is recommended.

On minimum zone selection two outlets should be considered for airflow and noise purpose and to decrease final air duct static.

When an air balance is carried out, it is recommended that the airflow is adjusted at the branch take off points for each outlet instead of using the balancing blades at the supply air outlet. This will also reduce noise at the supply air outlet/grille and eliminate any excessive static pressure across the outlet.

NOTE

Supply and Return Air Plenums must be as per ActronAir Plenums or equal to, or lower static pressure.

Return Air Grille Sizes

Careful consideration is to be given to pressure drops through return air grilles, air filters and crimped or tight bends in duct. Grille sizes shown are based on a velocity of 2.5 m/s, sizes shown are free area, please ensure your suppliers are aware of these requirements.

Model	Nominal Supply Air Flow (L/s)	Minimum Return Air Grille Sizes (free area)	Maximum Supply Air Flow (L/s)	Minimum Return Air Grille Sizes (free area)	Recommended* Return Air Grilles (For nominal air flow)
EVV13AS / EFV13AS	650	0.26 m ²	780	0.31 m ²	550 x 750 = 0.41 m ²
EVV15AS / EFV15AS	770	0.30m ²	920	0.37m ²	500 x 900 = 0.45m ²
EVV17AS / EFV17AS	890	0.36m ²	1060	0.42m ²	600 x 900 = 0.54m ²

* Based on 80% free face area.

NOTE

To achieve maximum airflow you may need to up size your return air grille one size larger than our Recommended Return Air Grilles shown above.

Care must be taken to identify return air paths for each zone for minimal static. This may include undercut doors or additional return air duct and grilles.

Other Guidelines

- Larger master bedrooms or parents retreats may have privacy issues with undercut doors, so a separate return duct or transfer duct may be needed. The use of walk in robes for positioning of return air grilles allows for a better finish.
- Special attention may also be required in home theaters where rooms are sealed for noise breakout. A dedicated return air duct with zone barrel linked to the supply air zone barrel is recommended.
- Small critical areas such as a study, which are below the minimum air flow and duct sizing, would need to be coupled on the same zone as with another area.
- Dual Master controllers are also recommended for two story homes or larger single story homes.

Unit Lifting Procedures

WARNING

WH&S regulations must be observed and will take precedence during lifting process.
Do not use pipes or tube coming out from the unit to lift the unit.

Crane Lifting Method

DANGER

Make sure rigging equipment, accessories and plant are sufficiently and safely capable to lift the unit in order to prevent potential damage to property, severe personal injury or death. Please check unit weight and weight distribution points on unit drawing dimensions section.

NOTES

- Crane lifting method is recommended for high rise lifting.
- Refer to catalogue for unit weight before selecting shackles and slings.
- Lifting procedure and unit model shown are suggestions and for illustration purposes only.
- It is highly recommended that installer observe current industry safe rigging and lifting procedure.

NOTE

All drawings are for illustration purposes only. Actual unit may vary depending on the model.

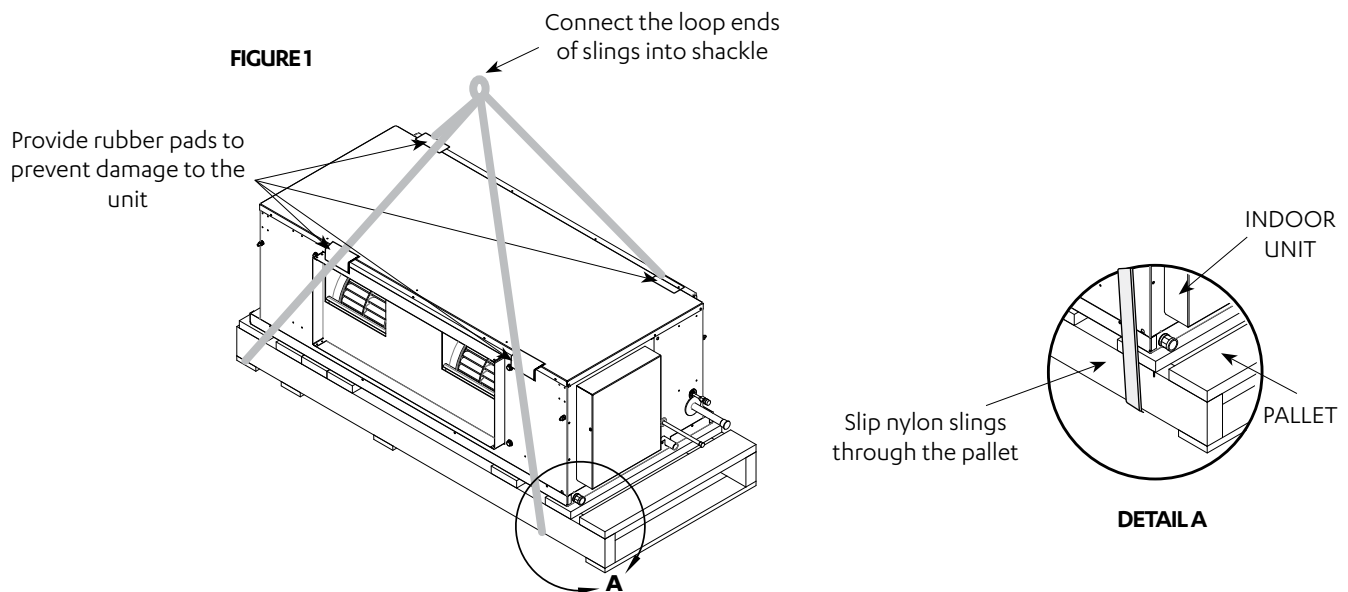

Equipment Required For Crane Lifting:

- 1 x shackle
- 2 x nylon slings
- 4 x rubber pads

NOTE

Refer to catalogue for unit weight before selecting shackles and slings.

Procedure:

1. Slip nylon slings through the pallet as shown in Figure 1.
2. Use Bow or Dee shackle to connect the slings.
3. Ensure slings are protected by rubber pads or similar if slings are draped across unit edges, corners, or air grilles . This will prevent the unit from being damaged during lifting.
4. Test lift the unit to determine exact unit balance and stability before hoisting it to the installation location.

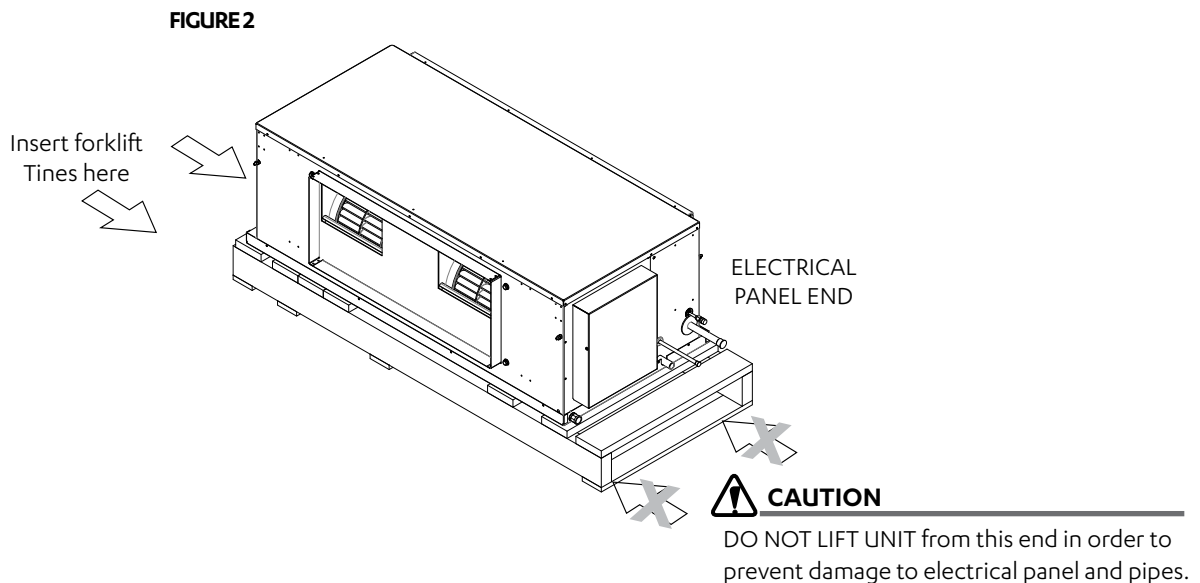
Fork Lift Method**Procedure:**

1. To move the unit around with a forklift, insert the fork tines through the unit feet assembly, as shown in Figure 2.
2. Do not lift the unit through the electrical panel end of the unit (See illustration for location of electrical panel end).

CAUTION

Length of fork lift tines must pass the unit middle section, in order to safely carry the unit.

Pallet Dimensions

EVV13AS / EVV15AS / EVV17AS

PALLET FORK LIFTING HOLE DIMENSIONS
ALL DIMENSIONS IN MM.

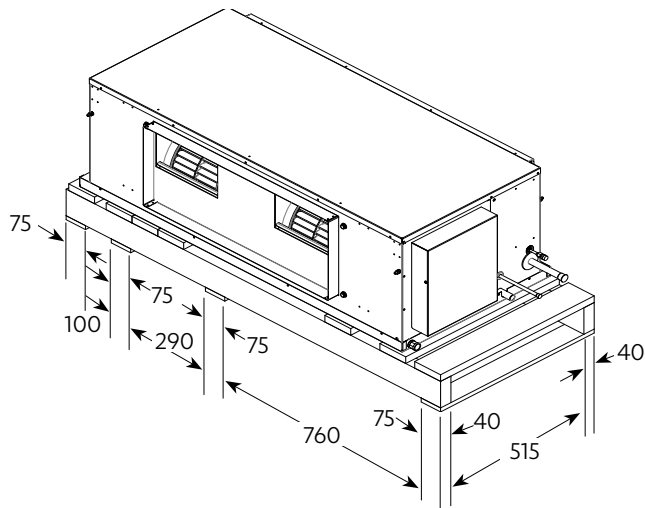

Safety Drain Tray

NOTES

- Do not use pipes or tube coming out from the unit to lift the unit.
- Support drain line for long pipe run.
- Refer to unit dimension page for specification of drain connectors.
- To reduce the risk of condensation forming on the drain line, the drain line should be covered with appropriate thermal insulation.
- Test condensate drain installation to ensure that water flows freely and does not leak. Also check that the drain tray does not overflow.
- All drawings are for illustration purposes only. Actual unit may vary depending on the model.

Suggested Minimum Slope To Ensure Correct Drainage

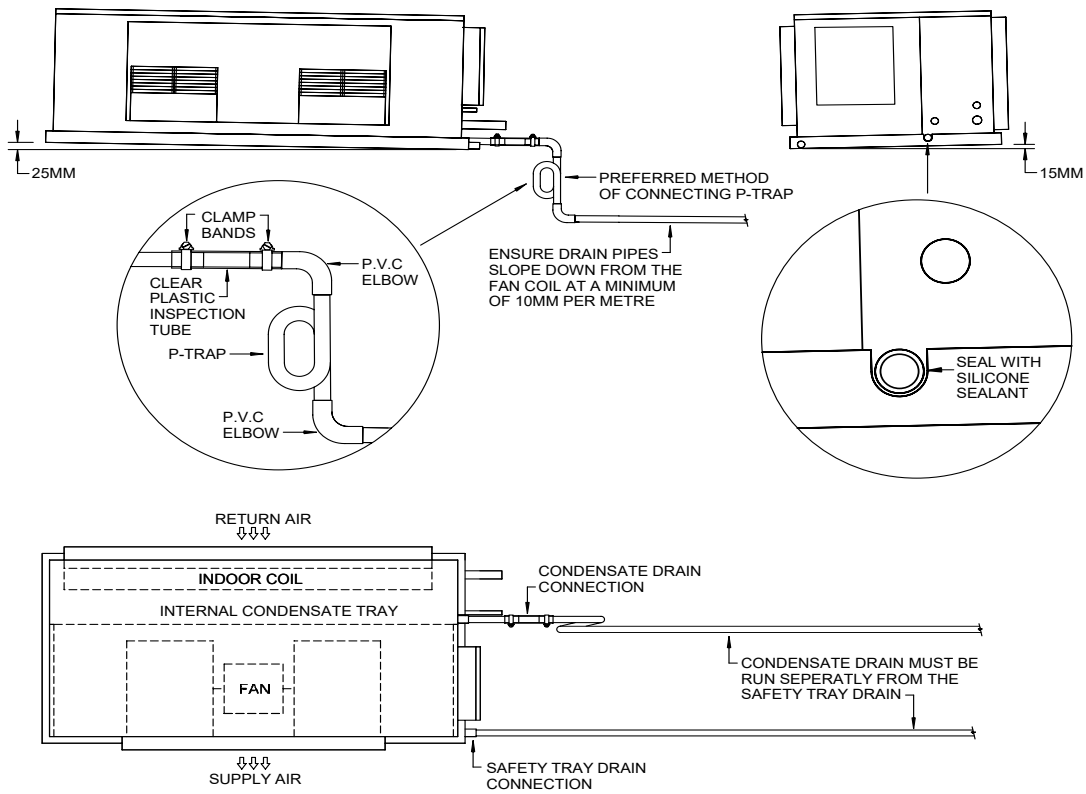

Suggested P-Trap Connection With Limited Height Clearance

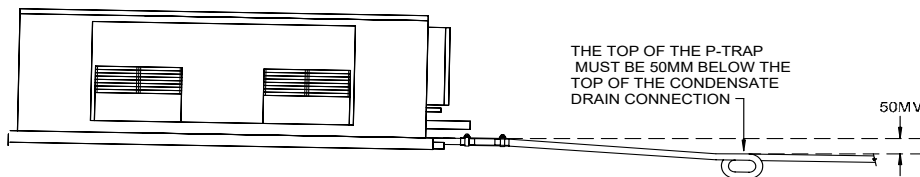

Suggested P-Trap Connection With Long Drain Runs

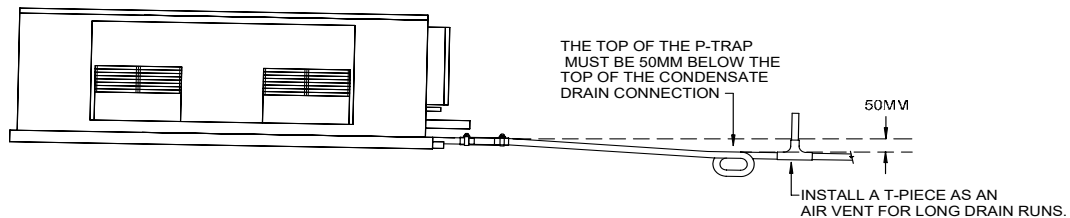

Zone Barrel Installation Instructions

In the installation of zone barrels, extra caution must be taken as damper motors are **IP20 Rated and MUST NOT BE INSTALLED IN AN AREA WHERE CONDENSATION WILL BE AN ISSUE.**

It is highly recommended that indoor units and accessories, particularly zone barrels, be mounted in the roof cavity. Mounting of zone barrels should be horizontally positioned ensuring that the damper motor is located on the upper half of the barrel's centerline (positions that range from 9 o'clock to 3 o'clock), as shown below:

It is also recommended that only ActronAir 24V zones be connected to this system using RJ45 cable connections. RJ12 connections are not compatible on these systems. Warranty may be void if third party zones cause damage to the system.

NOTES

All exposed metal surfaces of the zone barrel should be adequately insulated when connecting ductwork to ensure performance and reduce the risk of condensation.

All drawings are for illustration purposes only. Actual unit may vary depending on the model.

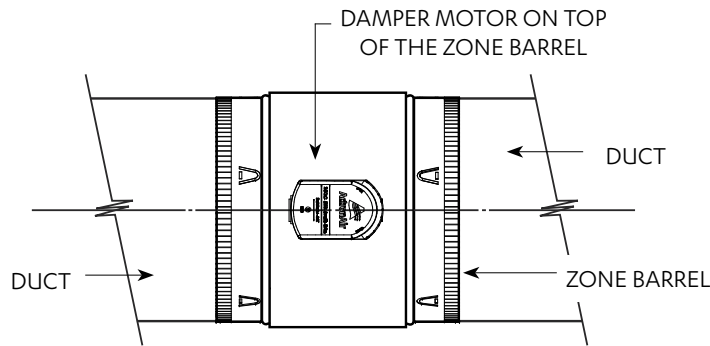

TOP VIEW

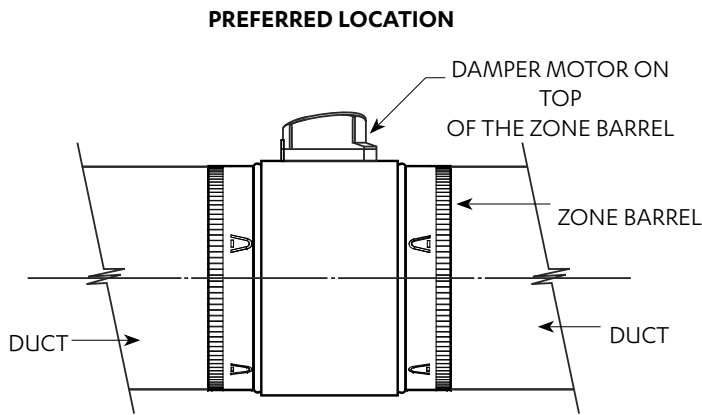

SIDE VIEW

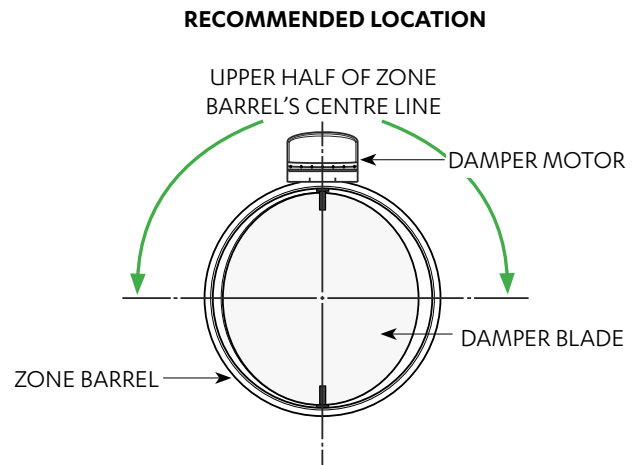

FRONT VIEW

Electrical Installation

All electrical work must be carried out by a qualified technician. Make sure all wiring is in accordance with local wiring rules. Wiring connections should be made in accordance with the wiring diagram provided.

DANGER

Live Electrical Supply !

- During installation of your air conditioning unit, it may be necessary to work in close proximity to live electricity. Only qualified technicians are allowed to perform these tasks.
- Follow all electrical safety precautions when exposed to live electrical components.
- Always make sure that all power supply, including remote controls, are disconnected before performing maintenance. Observe proper LOCK-OUT / TAG-OUT (LOTO) procedures to ensure that power cannot be inadvertently energised. Failure to disconnect power before maintenance procedure can result in serious injury or death.
- All electrical wiring must be in accordance with the relevant electrical authority rules and regulations.

CAUTION

STATIC SENSITIVE ELECTRONIC DEVICES !

- DO NOT handle electronic devices unless you are wearing an Anti-Static Wrist Strap that is connected to a EARTH. Failure to protect the electronic devices from static electricity may cause unrepairable damage.
- Static damaged electronic devices are NOT COVERED for replacement under warranty.

Wiring Diagram

The wiring diagrams specific for your air conditioning system are located on the inside of the electrical access panel.

Always refer all wiring installation, servicing and troubleshooting of this equipment to this diagram to ensure correct electrical connections are satisfied.

Supply and Power Requirements Procedure

It is the installer's responsibility to provide power supply wiring to the sub-mains isolator. Wiring should conform to the current electrical authority regulations and all wiring connections to be as per electrical diagram provided with the unit.

- Confirm that the power supply available is compatible with the unit nameplate ratings. The supply power must be within +6% to -6% of the rated voltage as per AS60335.1.
- Protect electrical service from over current and short circuit conditions in accordance with the latest edition of the AS/NZS 3000 or AS/NZS 3008 "Australian / New Zealand Wiring Rules". Protection devices are to be sized accordingly as per to the electrical specifications of the unit.
- Complete the outdoor unit power supply wiring into the sub-mains isolator.
- Secure the power cords and control cables that enters in/exits out the unit. Use the cable ties provided in the electrical panels.
- Provide proper unit earthing in accordance with local and national wiring rules.
- Installer to connect an appropriate load break (AC3) isolator in sub mains wiring.

Compressor Voltage Balance Requirement

Check the voltage at the mains supply terminals to determine if it is balanced. Voltage imbalance on three phase systems can cause motor overheating and premature failure. The maximum allowable imbalance is + 2.0% should voltage imbalance exceed this value, check unit wiring connections to locate and rectify faults or contact local supply authority.

Wiring Diagram

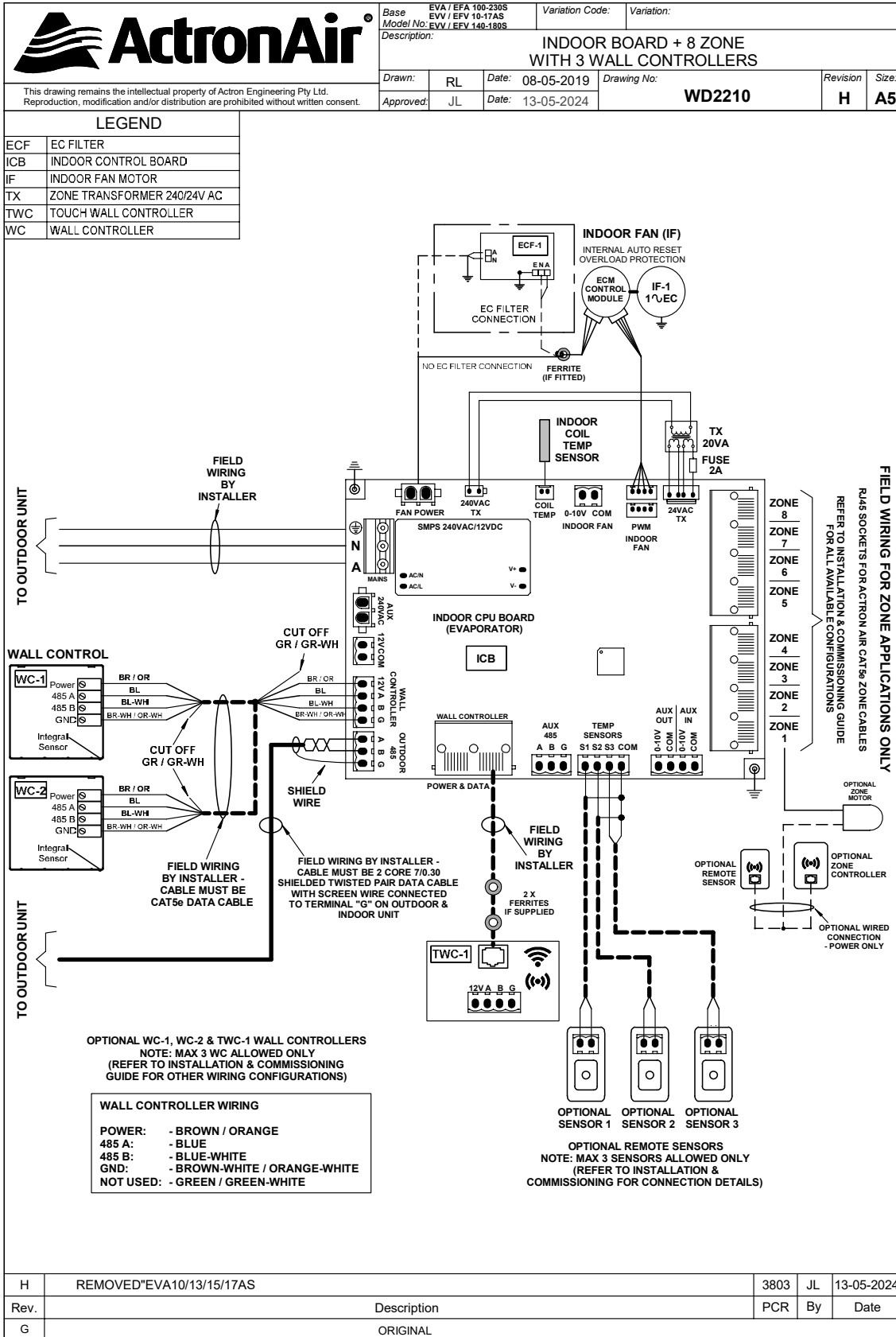

H	REMOVED*EVA10/13/15/17AS	3803	JL	13-05-2024
Rev.	Description	PCR	By	Date
G	ORIGINAL			

DESIGNS AND SPECIFICATIONS ARE SUBJECT TO CHANGE WITHOUT NOTICE.

Electrical Connection

NOTES

- To minimise noise interference, Data and Power cable clearance should be maintained as much as possible.
- All drawings are for illustration purposes only. Actual unit may vary depending on the model.
- All electrical components do not come with the unit, must be purchased separately.

DETAILED WIRING DIAGRAM IS PROVIDED WITH THE UNIT.

Outdoor Unit: Located at the back of electrical/compressor access panel.
 Indoor Unit: Located at the back of electrical box cover.

Split Unit

- ① MAINS WIRING (230/400VAC)
 (Single Phase + Neutral + Earth) 50Hz
 (Three Phase + Neutral + Earth) 50Hz
- ② INTER-CONNECTING POWER CABLE (230VAC)
 (Single Phase + Neutral + Earth) 50Hz
- ③ DATA CABLE TO WALL CONTROLLER
 (Cat5e UTP (AWG 24) Data Cable)
- - - - ④ EXTRA LOW VOLTAGE DATA CONTROL WIRING
 (2 Core Shielded Twisted Pair 7/0.30 (0.5mm²) Data Cable)

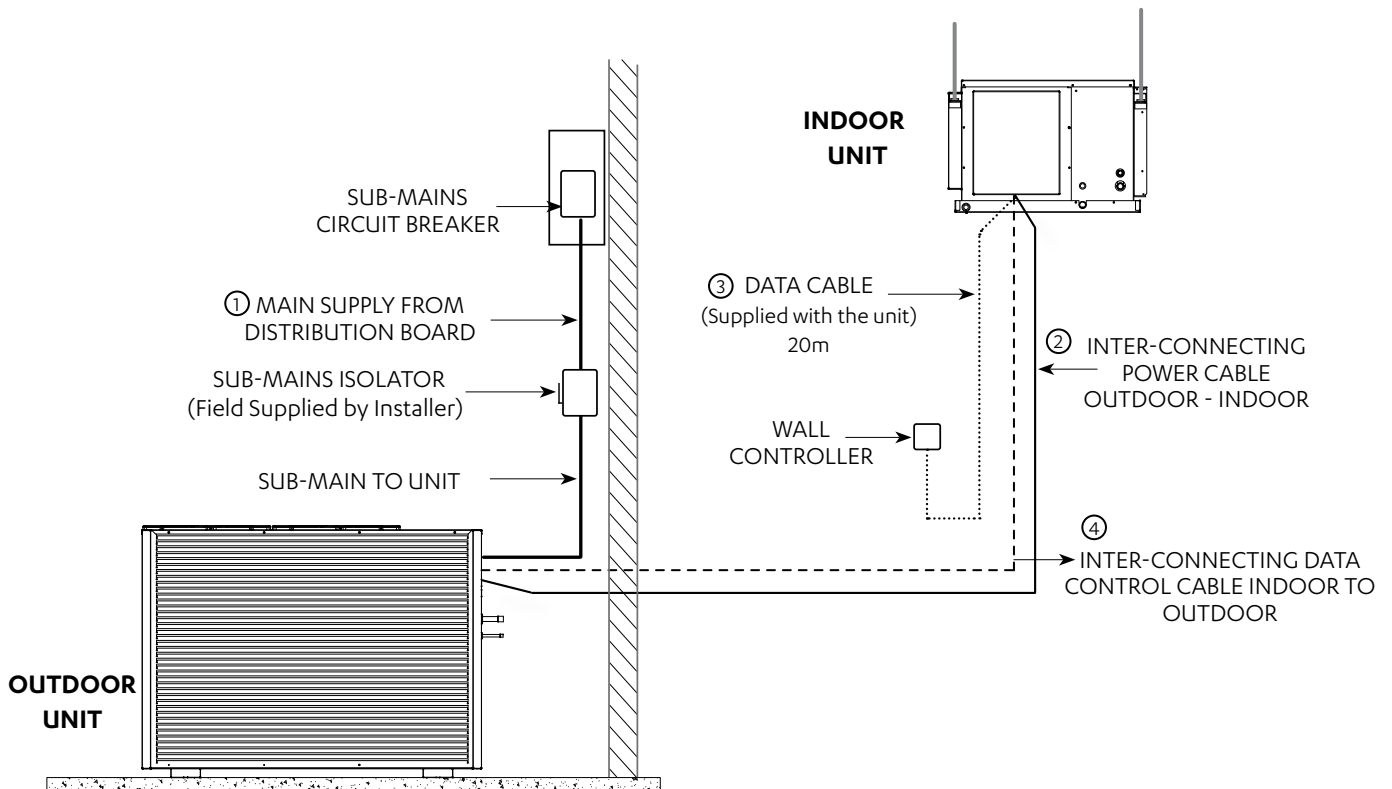

Data Cable Shielding Instructions

2 Core Twisted (ActronAir Part Number: AEDC2)

NOTES

- Maintain the twist of the core wires up to the Green Terminal Plug.
- Maximum strip length of outer insulation to the Green Terminal Plug is 50mm.
- Make sure the cable colors used for the Data Terminal in Outdoor Unit match the Data Terminal in Indoor unit.

Outdoor Unit Data Terminal (Green Plug)

“Terminal A” - White Wire

“Terminal B” - Black Wire

“Terminal G” - Shield Wire

Indoor Unit Data Terminal (Green Plug)

“Terminal A (+)” - White Wire

“Terminal B (-)” - Black Wire

“Terminal G” - Shield Wire

Insert data cable through the lower snap bushing and first cable tie on the right hand side of the electrical panel.

Connect core wires and shield wire into the Outdoor Board green terminal plug marked “INDOOR A, B and G”.

(Refer to unit wiring diagram for complete wiring connection details).

NOTE

All drawings are for illustration purposes only. Actual unit may vary depending on the model.

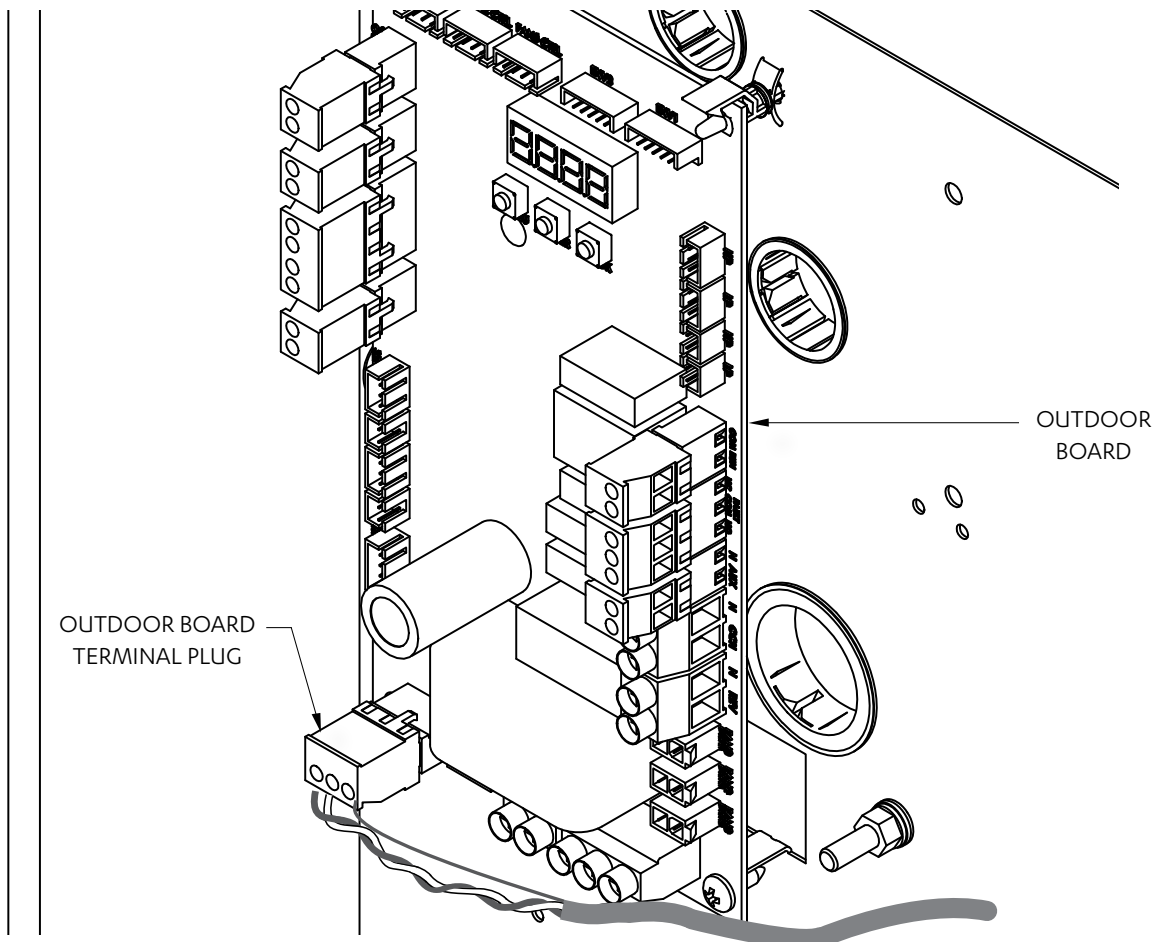

Circuit Breaker Size and Cable Size Recommendation

Model	Circuit Breaker Size
	Amps
CRV13AS / EVV13AS / EFV13AS	32A
CRV15AS / EVV15AS / EFV15AS	40A
CRV17AS / EVV17AS / EFV17AS	
CRV13AT / EVV13AS / EFV13AS	16A
CRV15AT / EVV15AS / EFV15AS	20A
CRV17AT / EVV7AS / EFV17AS	
PRV15AT	20A
PRV17AT	

Note:

Refer to the latest edition of AS/NZS 3000 or AS/NZS 3008 Australian/New Zealand Wiring Rules to determine required cable size.

Wall Controller Options

Wall Controller Options

A maximum of three (3) wall controllers in the below combinations is allowed per unit. See below table.

Options	Wall Controllers		
	C1	C2	C3
1st Option	NEO		
2nd Option	NEO	NEO	
3rd Option	NEO	NEO	LR7-1 / LC7-2
4th Option	NEO	LR7-1 / LC7-2	
5th Option	NEO	LR7-1 / LC7-2	LR7-1 / LC7-2
6th Option	LR7-1 / LC7-2		
7th Option	LR7-1 / LC7-2	LR7-1 / LC7-2	
8th Option	LR7-1 / LC7-2	LR7-1 / LC7-2	LR7-1 / LC7-2

NOTES

- NEO - Available in White (NTW-1000) and Black (NTB-1000).
- LC7-2, LR7-1 and LM-RS-2 - Available in White and Grey.
- In the instance of a combination of NEO and LR7-1 / LC7-2 being connected together, the NEO will always need to be addressed as C1.

Wiring Configuration : Recommended

NOTES

- Diagram shown below is a general representation only. Refer to individual unit wiring diagram for complete wiring connection details.
- Long runs beside Mains cables or TV antenna cables should be avoided.
- Wiring configuration for LR7-1 and LC7-2 wall controller is the same.
- Daisy connection is not allowed for the NEO wall controller.
- Two Ferrite Clips*, if supplied, are to be placed 200mm and 400mm from the NEO controller.

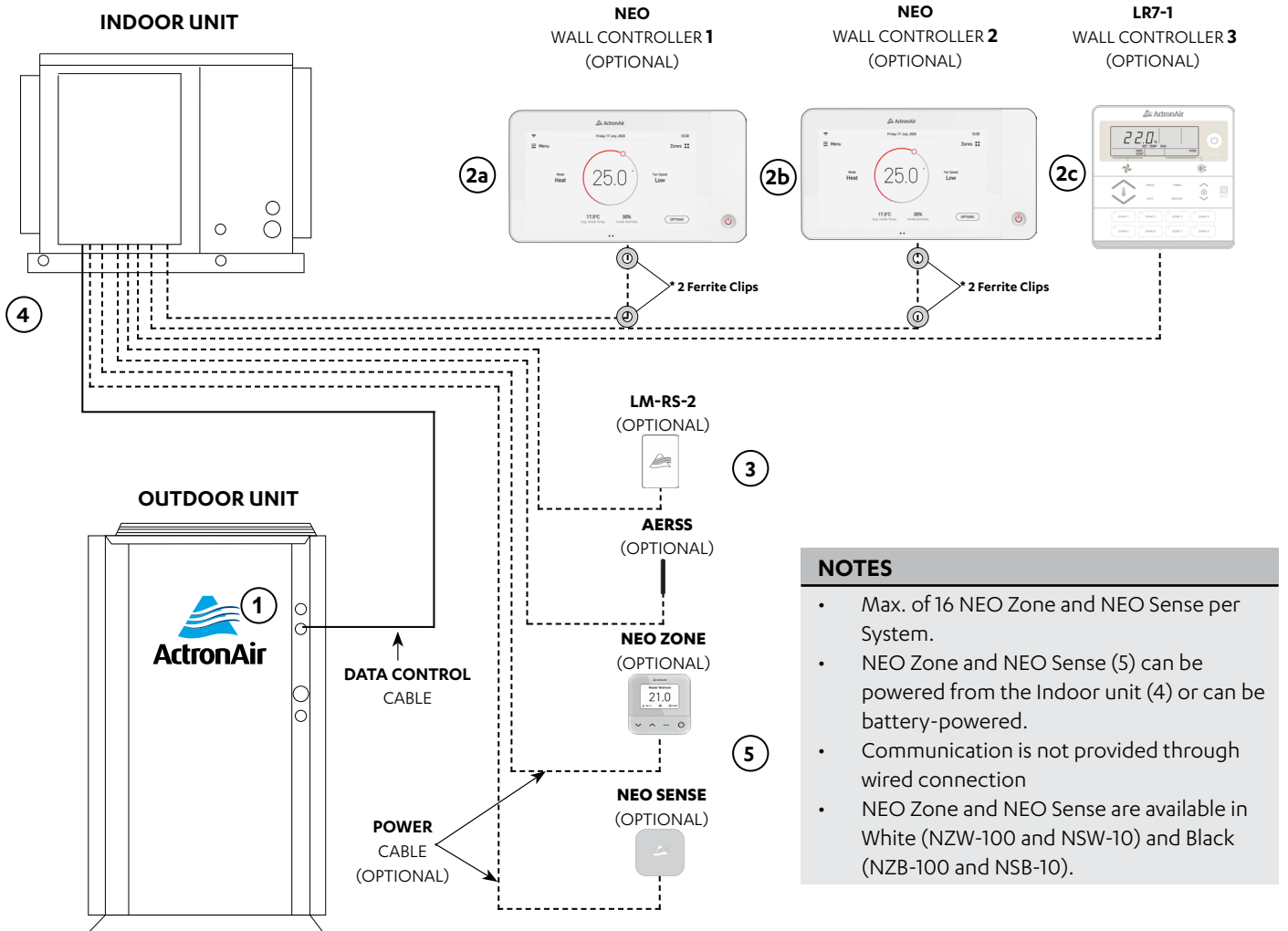

NOTES

- Max. of 16 NEO Zone and NEO Sense per System.
- NEO Zone and NEO Sense (5) can be powered from the Indoor unit (4) or can be battery-powered.
- Communication is not provided through wired connection
- NEO Zone and NEO Sense are available in White (NZW-100 and NSW-10) and Black (NZB-100 and NSB-10).

Item	Description	Maximum Cable Length
1 to 4	Outdoor PCB to Indoor PCB	100 m
4 to 2a, 4 to 2b	Indoor PCB to Wall Controller	90 m
4 to 2c	Indoor PCB to Wall Controller 3	100 m
4 to 3	Indoor PCB to Remote Sensor	100 m
4 to 5	Indoor PCB to ZC and ZS	100 m

Description	Cable Type
Indoor to Wall Controller	Cat5e UTP (AWG 24) Data Cable
Indoor to Remote Sensor	Cat5e UTP (AWG 24) Data Cable
Indoor to Outdoor Data Cable	2 Core (1 Pair) Twisted Pair, 7/0.30 (0.5mm ²) Shielded Data Cable

Wiring Configuration : Alternate

NOTES

- Diagram shown below is a general representation only. Refer to individual unit wiring diagram for complete wiring connection details.
- Long runs beside Mains cables or TV antenna cables should be avoided.
- Wiring configuration for LR7-1 and LC7-2 wall controller is the same.

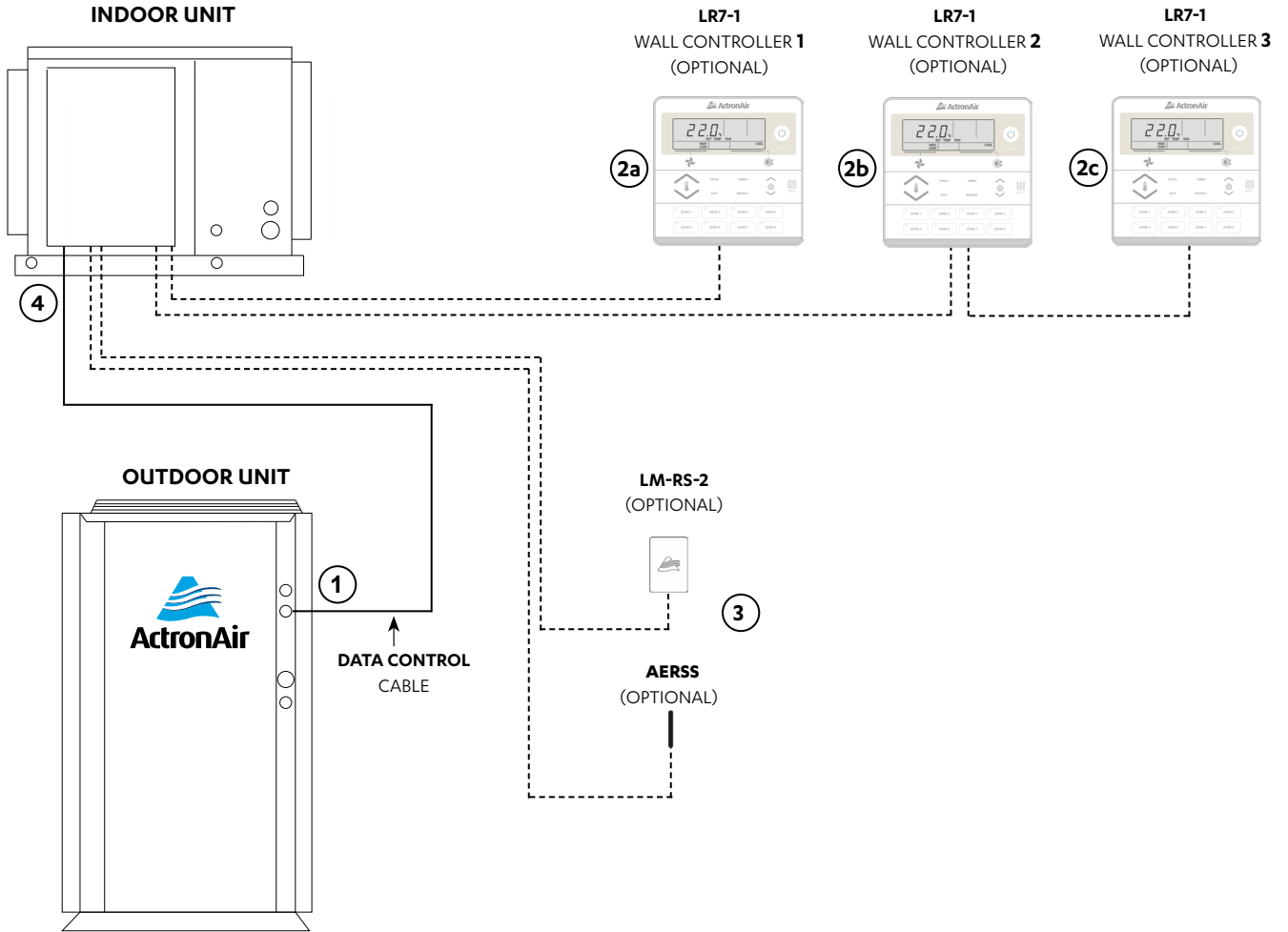

Item	Description	Maximum Cable Length
1 to 4	Outdoor PCB to Indoor PCB	100m
4 to 2a	Indoor PCB to Wall Controller 1	100m
4 to 2c	Indoor PCB to Wall Controller 3 (last controller)	75m total (Daisy Chain)**
4 to 3	Indoor PCB to Remote Sensor	100m

** Maximum Daisy Chain connection is up to 2 wall Controllers.

Description	Cable Type
Indoor to Wall Controller	Cat5e UTP (AWG 24) Data Cable
Indoor to Remote Sensor	Cat5e UTP (AWG 24) Data Cable
Indoor to Outdoor Data Cable	2 Core (1 Pair) Twisted Pair, 7/0.30 (0.5mm ²) Shielded Data Cable

Cable Length - Zoning

Neo Zone Controller / Neo Zone Sensor

NOTES

- All drawings are for illustration purposes only. Actual unit may vary depending on the model.
- Refer to individual unit wiring diagram for complete wiring connection details.
- * All Zone Device Power Cable : Cat5E Spec Cables with RJ45 Connectors and Cable Boots - Green Colour
- ** Total Cumulative length of all the aggregate cable must not exceed 250 meters. Consult ActronAir for longer cable length requirement.

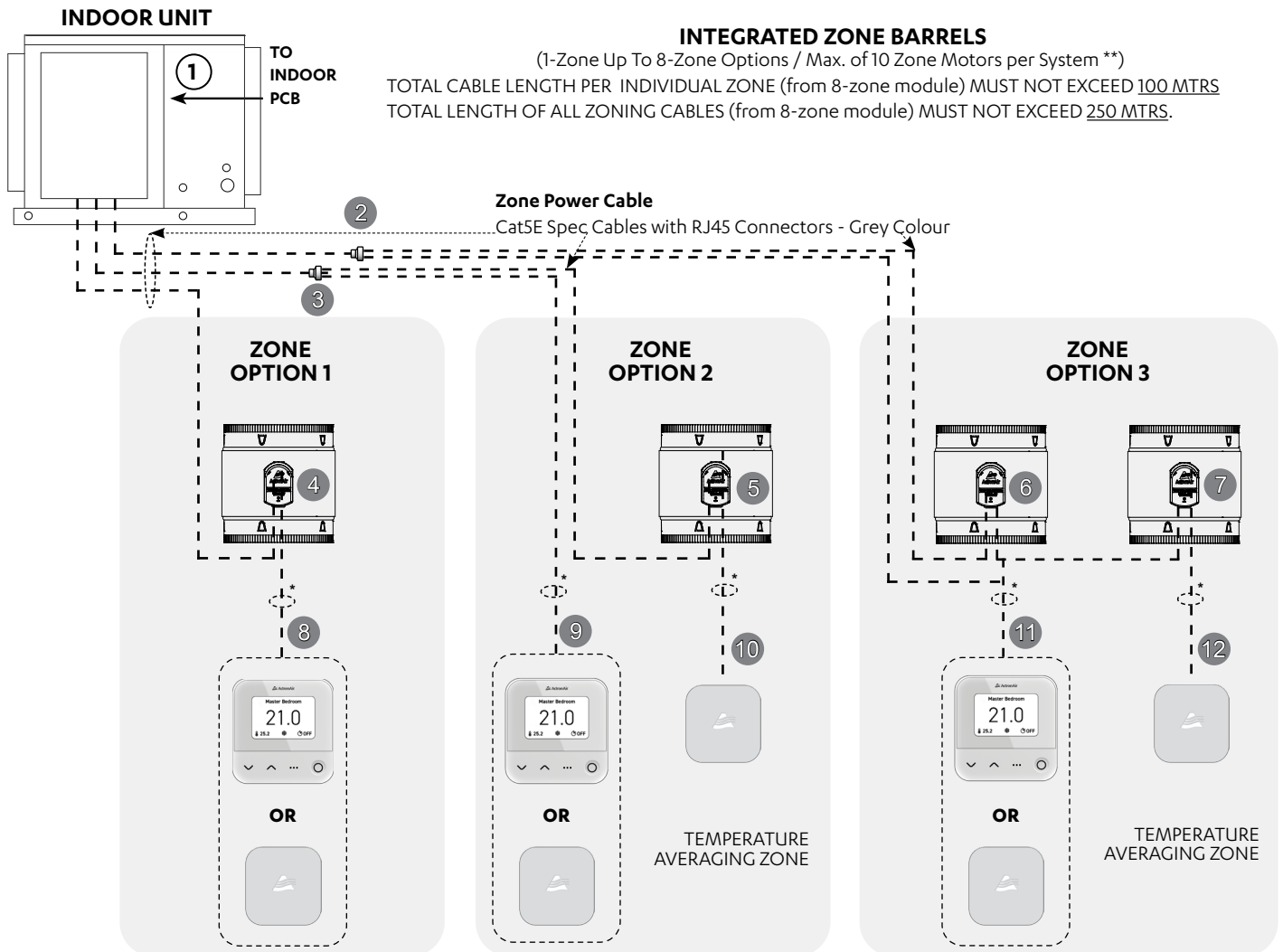

ITEM	DESCRIPTION	MAXIMUM CABLE LENGTH
1 to 2 1 to 3	8-zone module to 3-way cable joiner (P.N. 4070-012)	0.175m
1 to 8	8-zone module to zone controller	100m
4 to 8 5 to 10 7 to 12	zone barrel motor to zone device	50m
3 to 9 2 to 11	3-way cable joiner to zone device	50m

LR7-1 / LR7-2

NOTES

- All drawings are for illustration purposes only. Actual unit may vary depending on the model.
- Refer to individual unit wiring diagram for complete wiring connection details.

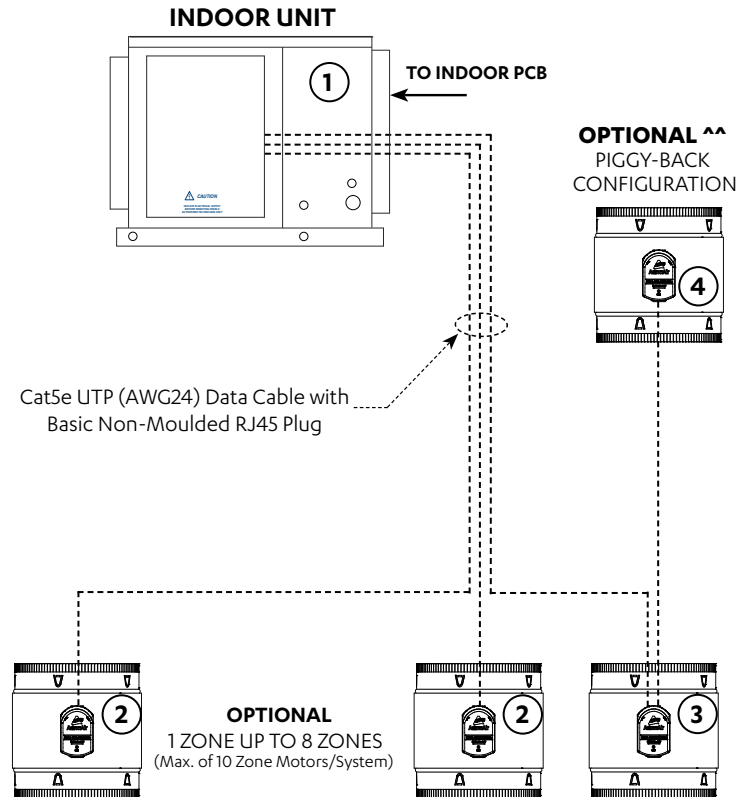

Item	Description	Maximum Cable Length * ^
1 to 2	Indoor PCB to Zone Barrels	100m
1 to 4	Maximum Cumulative Cable Length** (per zone - 8 zone)	100m
3 to 4	Zone Barrel 3 to Zone Barrel 4*** (Piggy Back)	95m

* Suggested Maximum Cable Length

Long runs beside Mains cables or TV antenna cables should be avoided where possible.

** Maximum Cumulative Cable Length per individual zone must not exceed 100 m per zone.

1 to 4 (Optional 4 Zones Piggy-Back Configuration), if 1 to 3 is 75m, then 3 to 4 must be 25m to make a total of 100m.

*** Recommended maximum cable length, providing total of preceding cable connections are only 5m.

^ **Total Cumulative length of all the aggregate cable must not exceed 500 meters.** Consult ActronAir for longer cable length requirement.

^^ 10 Zone Barrels are allowed and a maximum of 4 Zone Barrels are allowed per individual zone.

Wiring Connections

LR7-1 and LC7-2 Wall Control Wiring Connections

WALL CONTROL WIRING

POWER: - BROWN / ORANGE
 485 A: - BLUE
 485 B: - BLUE-WHITE
 GND: - BROWN-WHITE / ORANGE-WHITE
 NOT USED: - GREEN / GREEN-WHITE

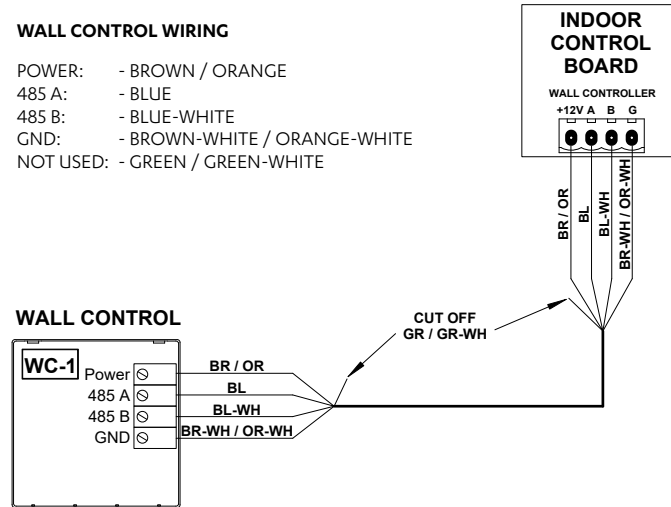

NEO Wall Control Wiring Connections

NOTES

Two FERRITE CLIPS, if supplied, should be installed 200 mm away and FERRITE 2 should be 400 mm away from the Wall Control.

NEO Hard Wiring

WALL CONTROL WIRING

POWER: - BROWN / ORANGE
 485 A: - BLUE
 485 B: - BLUE-WHITE
 GND: - BROWN-WHITE / ORANGE-WHITE
 NOT USED: - GREEN / GREEN-WHITE

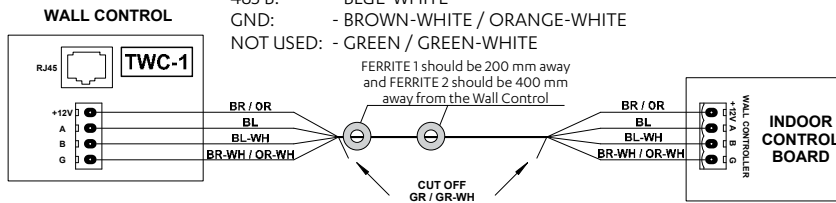

NEO RJ45 Wiring

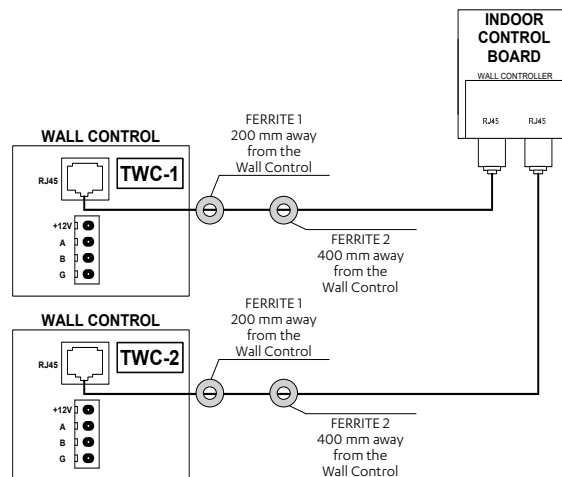

LM-RS-2 Optional Sensor Wiring Connections

REMOTE SENSOR WIRING

- PAIR 1: - BLUE / BLUE-WHITE
- PAIR 2: - ORANGE / ORANGE-WHITE
- PAIR 3: - GREEN / GREEN-WHITE
- PAIR 4: - BROWN / BROWN-WHITE

NOTE:

- PAIR 1 AND 2 USED FOR ILLUSTRATION PURPOSES ONLY.
- CUT OFF AND TERMINATE ANY UNUSED PAIRS TO ENSURE NO WIRING IS LEFT EXPOSED.

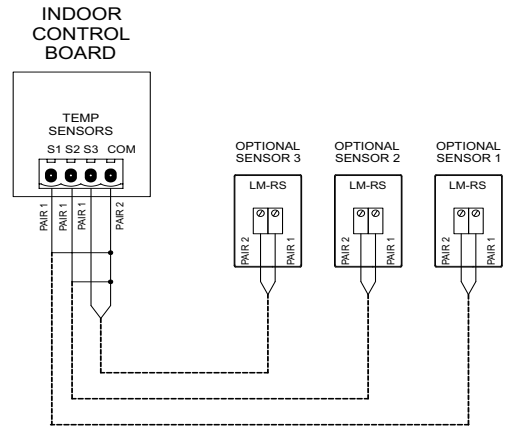

AERSS Optional Duct Sensor Wiring Connections

REMOTE SENSOR WIRING

- PAIR 1: - BLUE / BLUE-WHITE
- PAIR 2: - ORANGE / ORANGE-WHITE
- PAIR 3: - GREEN / GREEN-WHITE
- PAIR 4: - BROWN / BROWN-WHITE

NOTE:

- PAIR 1 AND 2 USED FOR ILLUSTRATION PURPOSES ONLY.
- CUT OFF AND TERMINATE ANY UNUSED PAIRS TO ENSURE NO WIRING IS LEFT EXPOSED.

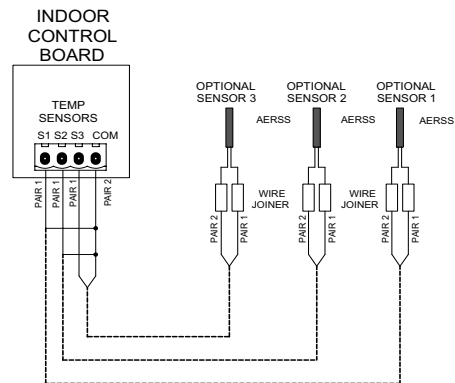

Indoor Commissioning Guide

Before activating the self-learn mode, ensure the following:

1. System should be in the OFF mode.
2. Ensure all connected zones are able to be turned on. If a connected zone cannot be opened, refer to Troubleshooting guide for more information.
3. Check the following:
 - Return air filter, box and grille are properly installed.
 - All doors or any other restrictions that may obstruct the air path back to the return and grille are open.
 - Adjustable outlets should be in open position and System Air Balance should be complete.

Initiating Self-Learn Mode (LR7-1 or LC7-2 Wall Control)

1. Press and hold the **FAN** button and **ON/OFF** button for 5 seconds or until the word **Lrn** appears on the display and release.
2. Press the **FAN** button once and release.
3. During operation of self-learn mode, **AUTO** will flash on the controller display.

NOTES

- If a self-learn passes **PAS** will display on the wall control.
- If a self-learn fails, **FAL** will display on the wall control. Refer to service manual for troubleshooting.
- To return to Main Menu, press the **EXIT** button.
- To cancel Self-learn Mode, press **ON/OFF** button or press the **EXIT** button.

Self-learn process for NEO Wall Controller

Follow the commissioning process in the NEO wall controller to complete self-learn.

NOTES

- Self-learn Mode should be activated when there are no obstructions in duct system layout.
- Whenever system duct layout will be changed, self-learn mode should be reactivated. This will allow the controller to learn the new duct layout.

Zone Commissioning

When the unit is powered on, zone detection will automatically start. This will take 2 minutes to complete. A zone detection can also be manually triggered on the LR7-1/LC7-2 controller by pressing the **ON/OFF** button and **Zone 1** button for 3 seconds. If a zone detection is triggered manually, all the Zone LED lights will flash until the zone detection is complete.

If the zone cannot be toggled between open and closed after zone detection is complete, the zone has not been detected. Therefore; zone motor connections and motor will need to be further inspected.

Automatic zone configuration:

Once the power will reset, Inzone Board will perform the automatic zone detection in three possible installed ways:

Case 1: Single zone system (No zone barrel connected)

- All zones should appear as OFF in Wall Control Menu 14.
- Last Zone Protection will be disabled
- All wall control zone lights are OFF.

Case 2: Multi zone system (Only zones motors no common zones)

- Only detected zones should appear to be ON, in Wall Control Menu 14.
- Last Zone Protection will be enabled for zone 1 only (unless changed from the Wall Control).
- Only detected zones are toggleable.

Case 3: Multi zone system (Common zones and zone barrel)

- Plug zone motors into InZone Board, skipping the number of ports required for common zones. E.g. for a system with 2 common zones and 2 zone motors, plug the zone motors into Zone 3 and Zone 4.
- The Common zones shall appear open but are not toggleable.
- Other zones other than common zones follow the same functionality as the zone motors above.
- User can also assign the sensor to the common or dump zones.

Manual zone detection:

Activation: Hold the **ON/OFF** button and **Zone 1** for 3 seconds.

When zone detection is manually performed all zone lights will flash.

NOTES

- If **Zone 1** is not detected then zone light will always be ON and will not be allowed to toggle.
- Other than **Zone 1** if any other zone is not detected, then wall control light will remain OFF.
- The unit will remain in standby during a zone detection. After a zone detection is complete, the unit will resume operation in its previous mode.

Maintenance Frequency Checklist

Regular servicing of equipment by a qualified technician is recommended every 12 months for residential applications and every quarter for commercial applications. Regular servicing of your unit helps in maintaining its optimum performance and reliability. **The following checklist and service periods are provided as a guide only, as some sites may require more frequent servicing.**

ELECTRICAL											
Parts	Service Period					Detail of Service Check	Service Methods				
	1 Mth	3 Mth	6 Mth	1 Yr	2 Yrs			3 Yrs	4 Yrs	5 Yrs	
Printed Circuit Boards				✓						Visual Inspection	Tighten Terminals as necessary on printed circuit boards
Electrical Connections				✓						Check all electrical terminals, mains, communications, etc	Re-tighten if loose.

INDOOR UNIT											
Parts	Service Period					Detail of Service Check	Service Methods				
	1 Mth	3 Mth	6 Mth	1 Yr	2 Yrs			3 Yrs	4 Yrs	5 Yrs	
Casing / Panels and Frames				✓						Visual check for damage, rust and dust accumulation.	For highly corrosive environment, wash panels quarterly with water and neutral detergent solution. Wax panels. Repair / re-paint where required.
Insulation				✓						Visual check for insulation conditions.	Repair / replace insulation material.
Fan				✓						Visual check for run out of balance and dust attached	Clean off dust as necessary to negate possibility of fan running out of balance
Motor				✓ Ω						Visual check on wiring. Insulation resistance check to be carried out annually	Measure insulation resistance. Reading should be more than 1MΩ.
Heat Exchanger				✓						Check for clogging by dust. Check for leaks / damage.	Clean air inlet side as necessary. Straighten any bent fins using fins comb.
Drain Pan/ Condensation line				✓						Check for obstructions and free flow of water	Clean to eliminate obstructions/ sludge and check condition of pan. Pour water to ensure flow
Filter*		✓								Check for clogging by dust.	Clean Filter
Temperature Readings				✓						Measure air on and air off	Place temperature probe in return and supply air of unit.
Damper Motors (if fitted)				✓						Visual inspection of motors open/closing. Ensure no obstructions	Drive motors opened and closed. Ensure correct operation
Duct Works				✓						Inspect duct works for air gaps.	Re-tape any loose ducts.

* Service period for filter cleaning may vary depending on operating time and surrounding environment.

Version History

DOCUMENT VERSION	BOM VERSION	UPDATE HISTORY
Ver 1	-0100	Released
Ver 2	-0100	Updated the WD
Ver 3	-020	R-32 restriction clause update
Ver 4	-020	Added new EVV dimensions
Ver 5	-020	Added Notes in Installation Instructions, Safety Drain Tray and Zone Barrel Installation Instructions Sections



©Copyright 2022 Actron Engineering Pty Limited ABN 34 002767240. ®Registered Trade Marks of Actron Engineering Pty Limited. ActronAir is constantly seeking ways to improve the design of its products. Therefore, specifications are subject to change without notice.