

# VARIABLE CAPACITY COMMERCIAL

## 72 - 96kW Indoor (R-410A Series)

Installation and Commissioning Guide



### Model Numbers

EVA720T

EVA850T

EVA960T

### IMPORTANT NOTE:

Please read this manual carefully before installing or operating your air conditioning unit.



## Table of Contents

<b>Introduction</b> .....	<b>3</b>
<b>Safety Instructions</b> .....	<b>4</b>
<b>Components Overview</b> .....	<b>5</b>
Indoor Unit Components Overview	5
Indoor Unit Electrical Panel Overview	5
<b>Unit Dimensions and Clearance</b> .....	<b>6</b>
EVA720T	6
EVA850T/ EVA960T	7
<b>Installation Instructions</b> .....	<b>9</b>
<b>Unit Lifting Instructions</b> .....	<b>11</b>
<b>Condensate Tray Drainage Instructions</b> .....	<b>12</b>
<b>Electrical Installation</b> .....	<b>13</b>
<b>Wiring Diagram 72kW</b> .....	<b>14</b>
<b>Wiring Diagram 85kW</b> .....	<b>15</b>
<b>Wiring Diagram 96kW</b> .....	<b>16</b>
<b>Electrical Connection</b> .....	<b>17</b>
<b>Data Cable Shielding Instructions</b> .....	<b>18</b>
<b>Circuit Breaker Size Recommendation</b> .....	<b>19</b>
<b>Wall Controller Options</b> .....	<b>20</b>
Wall Controller Options	20
Wiring Configuration : Recommended	21
<b>Wiring Connections</b> .....	<b>23</b>
LR7-1 and LC7-2 Wall Control Wiring Connections	23
NEO Wall Control Wiring Connections	23
LM-RS-2 Optional Sensor Wiring Connections	24
AERSS Optional Duct Sensor Wiring Connections	24
<b>Accessing Service and Technical via NEO</b> .....	<b>25</b>
<b>After Hours Logic with Timeclock (Scheduler)</b> .....	<b>27</b>
<b>Filter Alarm Configuration</b> .....	<b>30</b>
Filter Alarm Configuration	30
<b>Indoor Drain Pan Overflow Sensor</b> .....	<b>31</b>
<b>Maintenance</b> .....	<b>33</b>
<b>Maintenance Frequency Checklist</b> .....	<b>35</b>
<b>Start Up and Commissioning Report</b> .....	<b>36</b>
<b>Version History</b> .....	<b>37</b>

## Introduction

**CONGRATULATIONS** on your purchase of an ActronAir air conditioning system! This unit has been designed and engineered to provide optimum air conditioning and to achieve maximum energy efficiency.

Your air conditioning system has been manufactured from the highest quality materials. Numerous “in house” and “external” inspection and test procedures were conducted to your air conditioner to ensure satisfactory operation.

### Information About This Guide

This guide provides installation instructions, specific to your ducted unit. Read this manual thoroughly and take into consideration all specifications and instructions to ensure correct installation and safe operation of your air conditioning system.

#### NOTE

Print a copy of this document and keep it for future reference. Ensure all technicians that work on the unit can refer to this manual at any time.

### Product Inspections

Check your air conditioning unit and all items against the invoice upon receiving your shipment. Inspect the unit, components and accessories for any sign of damage. If there is any damage to the unit, contact ActronAir Customer Care Department immediately on: **1300 522 722** to obtain a Goods Return Number.

Check the unit nameplate to verify the model, serial number, electrical rated specifications are correct.

### Codes, Regulations And Standards

The installer and/or contractor assumes responsibility to ensure that unit installation complies with the relevant council, state / federal codes, regulations and building code standards. All electrical wiring must be in accordance with current electrical authority regulations and all wiring connections to be as per electrical diagram provided with the unit

### Important Safety Symbols And Labels

Safety Symbols and labels appear at appropriate sections throughout this manual to indicate immediate or potential hazards. Pay full attention and comply to the safety information and instructions. Failure to follow safety instructions increases the risks of personal injury, death and/or property damage. Damages to the product as a result of such failure may void warranty.

ActronAir has endeavoured to provide sufficient safety warnings and recommendations, however current and prevailing WH&S regulations must be observed and will take precedent whenever performing the installation instructions discussed in this manual.

## Safety Instructions

- Only licensed HVAC technicians\* should install and service air conditioning equipment. Improper service or alteration by an unqualified technician could result in significant and major damage to the product or property which may render your warranty null and void. Such unqualified service could also lead to severe physical injury or death. Follow all safety instructions in this literature and all warning labels that are attached to the equipment.
- Prevailing WH&S regulations must be observed and will take precedence to the safety instructions contained on this manual. Safe work practices and environment must be the paramount importance in the performance of all the service procedures.
- Ensure that unit installation complies with relevant council regulations and building code standards.
- All electrical wiring must be in accordance with current electrical authority regulations and all wiring connections to be as per electrical diagram provided.
- Secure the fans against accidental contact. Beware of pinch point and sharp edges which can cause cutting injury.
- Always wear appropriate PPE, remove any dangling jewelery and protect long hair by wearing a cap.
- Make sure that safety guards and panel covers are always firmly secured and not damaged before and during operation of unit.
- This appliance is not intended for use by young children or infirm persons unless they have been adequately supervised by a responsible person to ensure that they can use the appliance safely. Young children should be supervised to ensure that they do not play with the appliance.
- Installer must incorporate a means of electrical disconnection (isolator) in the sub mains fixed wiring in accordance with the latest edition of the AS/NZS 3000 (also known as Australian Wiring Rules).
- Secure the power cords and control cables that goes in/out the unit. Use the cable ties provided in the control box.
- This unit is designed for use with R-410A refrigerant only.

\*Qualifications required will be appropriate Electrical, Refrigeration and Refrigerant Handling License and Training dependent on local State/Territory regulations.

### DANGER

#### **Hazardous Voltage - Risk of Electrocutation.**

TURN-OFF the power from main isolator before proceeding with any service work of the unit. Observe proper LOCK-OUT/TAG-OUT (LOTO) procedures for electrical appliances in order to prevent accidental switching-on of the power supply.

### WARNING

EC Motors and Compressor Drives are fitted with high power capacitors and can have dangerous residual voltages at motor/drive terminals after power has been isolated. Wait at least 5 minutes after power isolation and test for any residual voltage before beginning service work.

### CAUTION

#### **Beware of Rotating Fans !**

Ensure that indoor and outdoor fans are isolated and have come to a complete stand still before servicing the equipment. Beware of pinch point and sharp edges which can cause cutting injury. Secure the fans against accidental contact. Always wear appropriate PPE and remove any dangling jewellery and protect long hair by wearing a cap. Ensure that no loose clothing can be caught / entangled in moving parts.

### **VISUAL INSPECTION AND WORK ASSESSMENT**

Work areas and conditions must first be assessed and evaluated for any potential hazardous conditions. It is also important to be familiar with the unit parts and components before proceeding with any service task.

## Components Overview

### Indoor Unit Components Overview

**NOTES:**

Drawing is subject to change without notice.  
 Drawing for illustration purposes only (may vary depending on capacity)  
 EVA720T has a single fan configuration

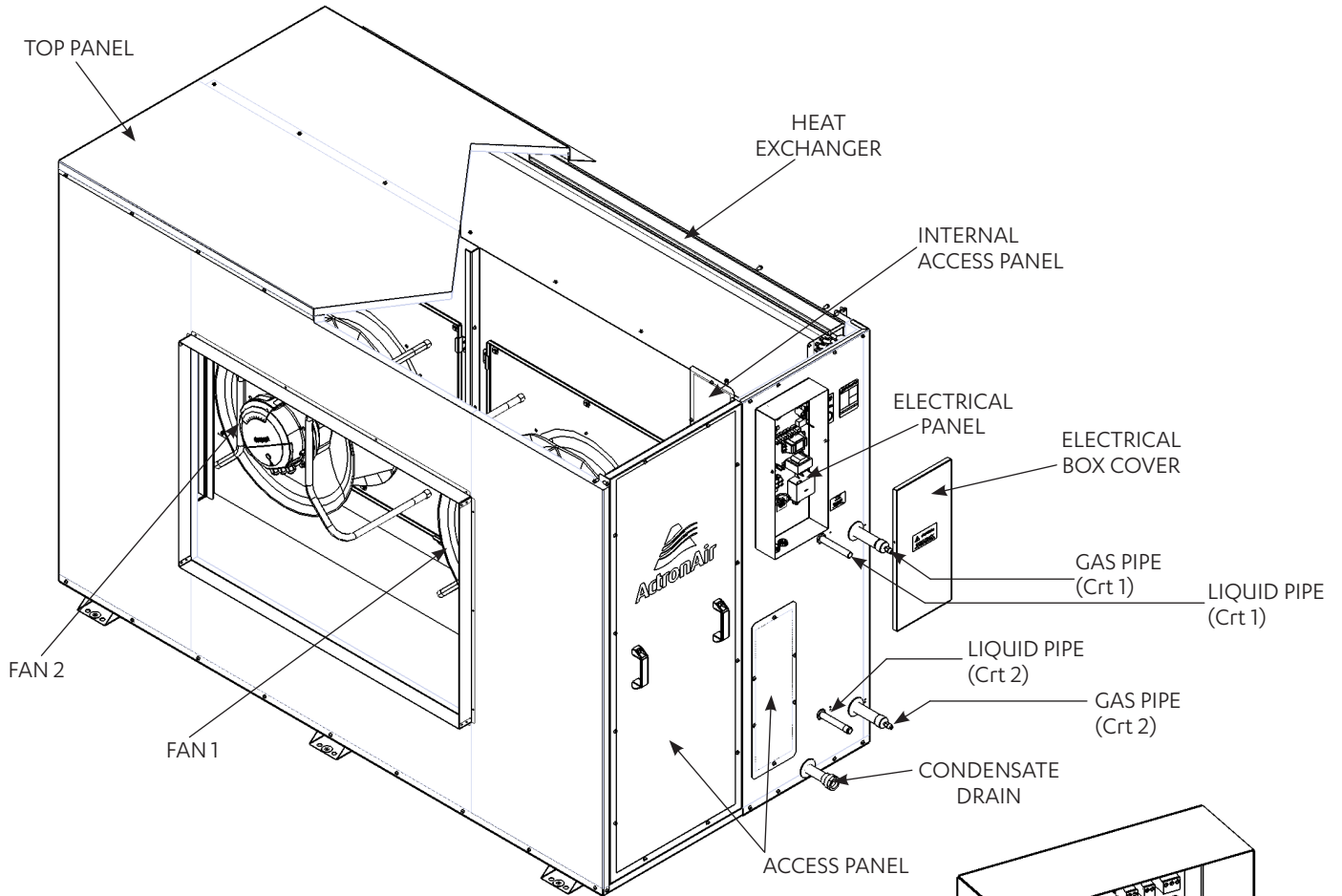

### Indoor Unit Electrical Panel Overview

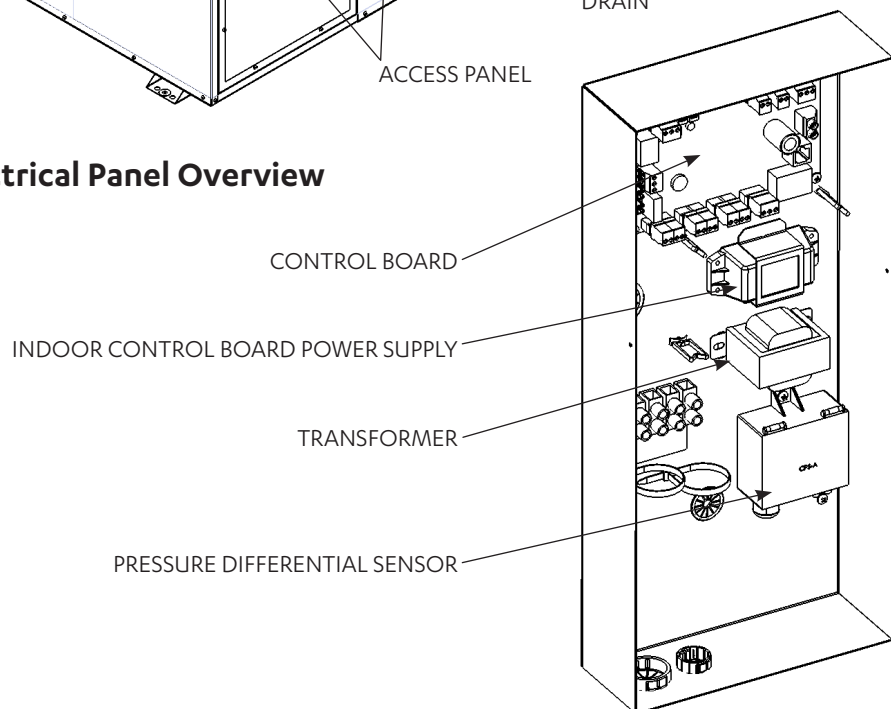

## Unit Dimensions and Clearance

### EVA720T

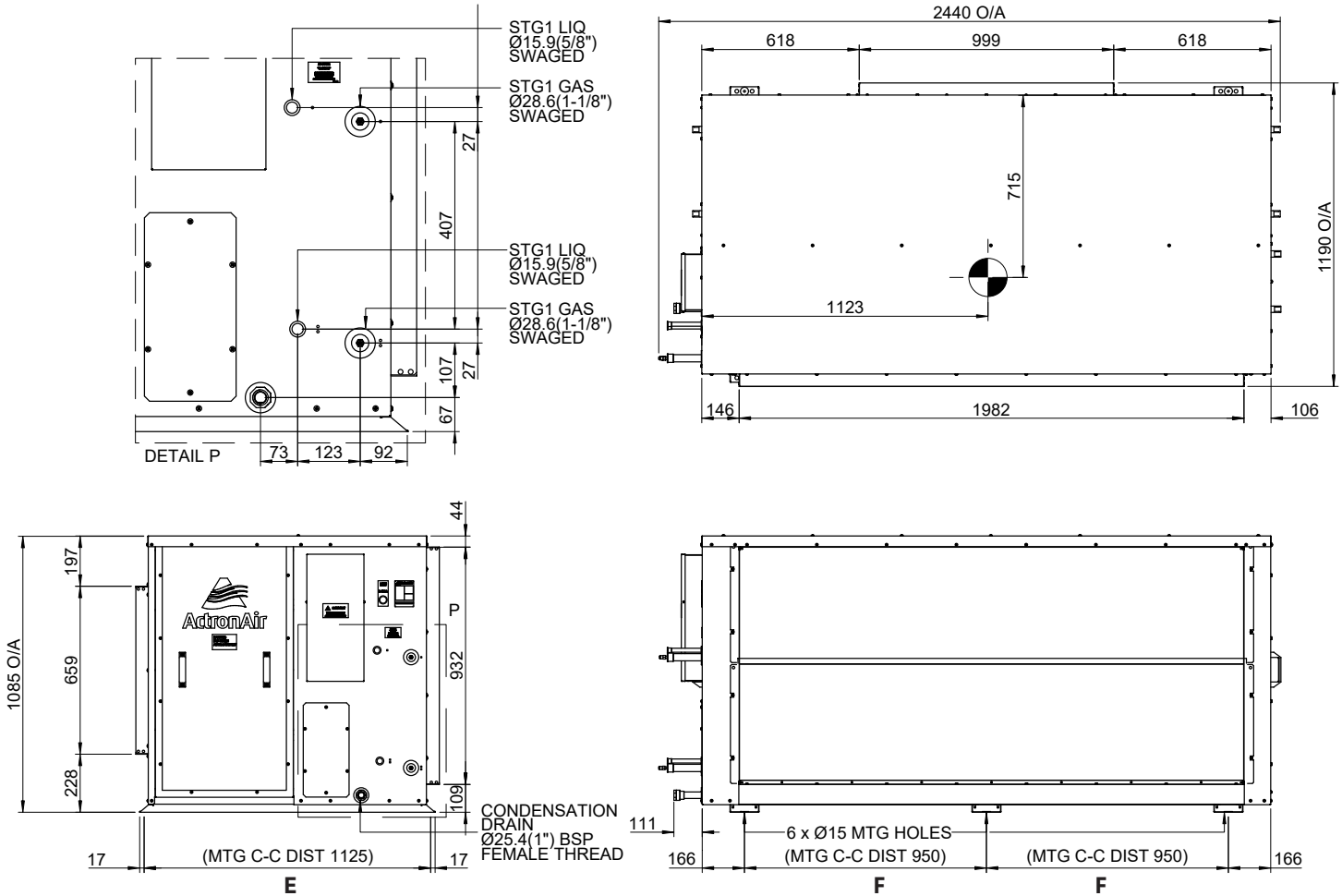

#### NOTES:

- Do not scale drawing. All dimensions are in mm unless otherwise specified. Refer to corresponding unit dimensional drawing for mounting hole details.
- Drawing is subject to change without notice.
- Use M12 Bolt for feet mounting
- Not to scale drawing. All dimensions are in mm unless otherwise specified.
- Refer to corresponding unit dimensional drawing for mounting hole details.

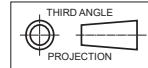

Unit Model Number	Overall Nominal Dimension (OA)			MTG C-C DIST Mounting Distance Base Foot (Centre to Centre)		Supply Duct	Return Duct	Gas Pipe	Liquid Pipe
	H	W	D	F	E	H-SD x W-SD	H-RD x W-RD		
EVA720T	1085	2440	1190	950	1125	659 x 999	932 x 1982	Ø 28.60 mm (1-1/8") Swaged	Ø 15.88 mm (5/8") Swaged

EVA850T/ EVA960T

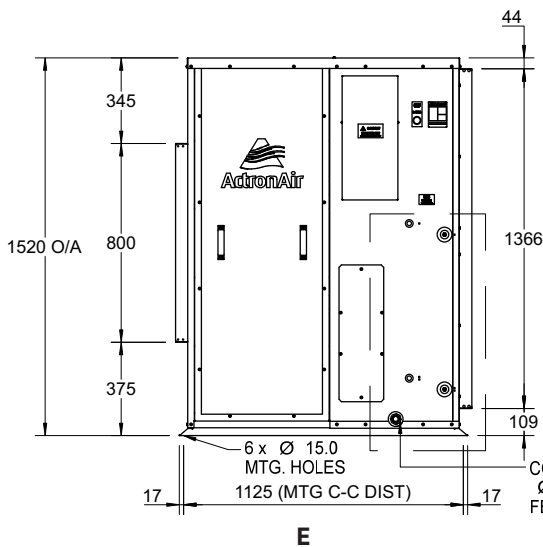
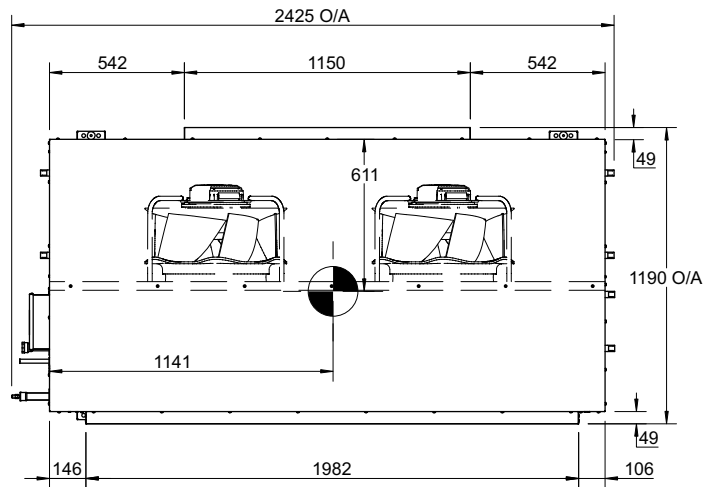
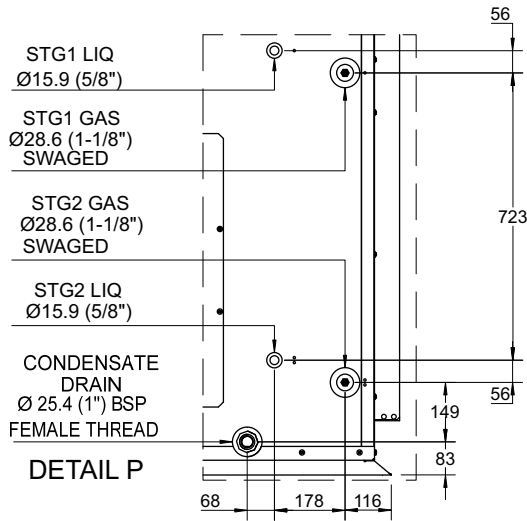

P

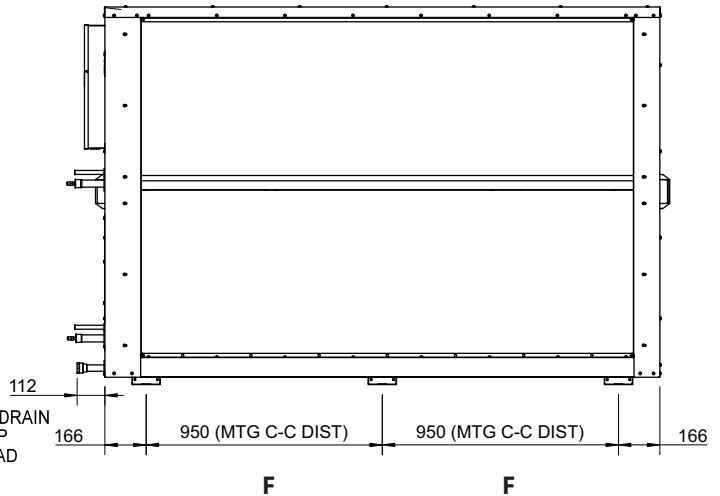

**NOTES:**

- Do not scale drawing. All dimensions are in mm unless otherwise specified. Refer to corresponding unit dimensional drawing for mounting hole details.
- Drawing is subject to change without notice.
- Use M12 Bolt for feet mounting
- Not to scale drawing. All dimensions are in mm unless otherwise specified.
- Refer to corresponding unit dimensional drawing for mounting hole details.

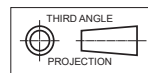

Unit Model Number	Overall Nominal Dimension (OA)			MTG C-C DIST Mounting Distance Base Foot (Centre to Centre)		Supply Duct	Return Duct	Gas Pipe	Liquid Pipe
	H	W	D	F	E	H-SD x W-SD	H-RD x W-RD		
EVA850T	1520	2425	1190	950	1125	800 x 1150	1366 x 1982	Ø 28.60 mm (1-1/8") Swaged	Ø 15.88 mm (5/8") Not Swaged
EVA960T									

Indoor Unit Service Access Clearances

NOTE

Drawing shown below is for illustration purposes only. Actual unit may vary depending on model.

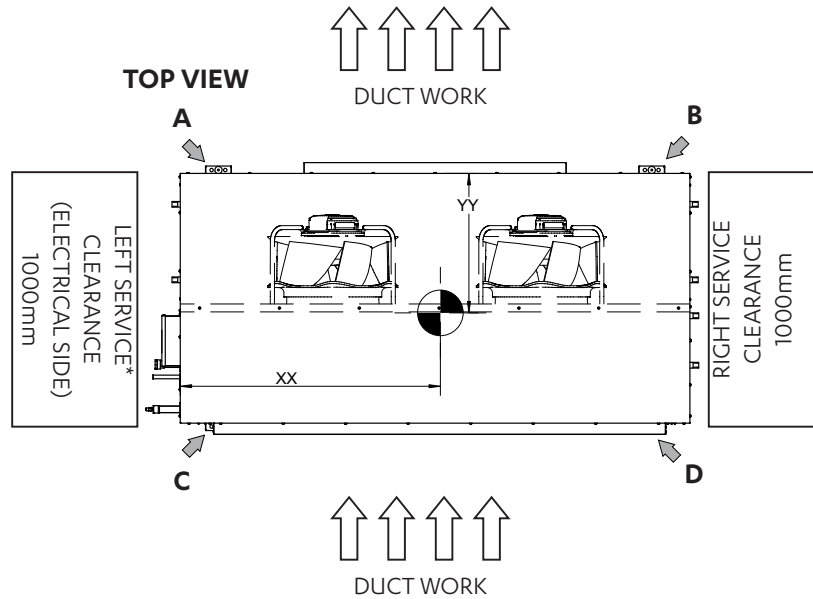

Notes:

Height Clearance is 500 mm

\*Electrical box and/or pipe connections are located on the left side of the indoor unit.

Model Number	Unit Weight (kg)	Corner Mounting Point Weights (kg)				Centre Of Gravity Position	
		A	B	C	D	XX	YY
EVA720T	296	76	34	74	112	1123	715
EVA850T	368	40	101	147	80	1127	638
EVA960T	387	108	59	90	130	1141	611

NOTES:

- Not to scale drawing. All dimensions are in mm unless specified. Refer to corresponding unit dimensional drawing for mounting hole details.
- Service Access Areas and Spaces for Airflow Clearances are suggested minimum based on the condition that the spaces around the units are free from any obstructions and a walkway passage of 1000 mm between the units or between the unit and the outside perimeter is available.
- Minimum service access areas and spaces for airflow clearances are responsibilities of the installer, ActronAir will not be held liable for any extra charges incurred due to lack of access and space for airflow.
  - Left Service Clearance can be 600mm minimum if Right Service Clearance is applicable.
  - Right Service Clearance can be 100mm minimum if Left Service Clearance is applicable.
  - Height Service Clearance can be 100mm minimum if Left Service Clearance is applicable.



## Installation Instructions

The installation instructions provided below are intended as a guide only and does not supersede the relevant council, state and federal codes, regulations and building code standards. Compliance and consultation with the authorities having jurisdiction with the installation of this equipment is the responsibility of the installer. ActronAir will not be held liable for any damages or costs as a result of the installer's failure to comply. Please refer to the matching outdoor unit Installation and Commissioning Guide for further information and details.

### Lifting The Unit

The installation instructions provided, in Unit Lifting Procedures, adhere to WH&S regulations for safe and secure lifting practices in order to prevent physical injury. The suggested lifting procedures are outlined as reference guide to safely lift and transport the unit, however, this does not over rule the industry WH&S practices.

### Location

This unit is intended for indoor installation only. It is highly recommended that this indoor unit and accessories, particularly zone barrels, be mounted in the roof cavity.

Mount the unit in a stable and rigid support wherein the weight is properly distributed, such as roof joist and rafters. Take into consideration the minimum service access clearances provided in the unit drawings.

Locate the indoor unit away from the areas where noise is a critical factor. Use rubber mounting pad (not supplied) in order to minimize the transfer of noise and vibration into building structures.

An optional hanging bracket assembly and rubber grommet (supplied as standard with some models) is also available to secure the indoor unit into the roof rafters. This installation configuration is most suitable for installation that require the unit to be rigidly secured up from the roof joist.

#### NOTE

In locations where high humidity is expected, additional insulation shall be applied to the indoor unit.

### Condensate and Safety Tray Drainage

An integrated safety drain tray is provided as a standard inclusion to your indoor unit in order to reduce the potential of condensate damage to the roof. Drain Kit (not included in some models) is provided for the condensate drain to be externally trapped from the indoor unit. Suggested condensate and safety tray drainage instructions are provided at the proceeding page for your reference.

#### NOTE

The included safety tray is provided for collection of internal condensation and for back up in case of main drain blockage. In locations where high humidity is expected, additional insulation or safety tray may be required to provide protection for externally formed condensation.

### Supply Air and Return Air Duct

The indoor unit is supplied with duct flange as standard in order to facilitate the system's duct connection into the unit. Supply and return air duct works must be adequately sized to meet the system's air flow and static pressure requirements. Refer to the unit drawing for supply air and return air duct dimensions, specific to your requirement.

#### NOTES

In locations where high humidity is expected, ensure appropriate duct insulation level is considered for the environment. Inadequate insulation can result in condensation forming on the ductwork's surface, potentially leading to dripping condensation on the ceiling.

Ducted work should be adequately supported in order to prevent cold bridging.

Fit a flexible duct connection in between the unit and the duct system, where noise and vibration is a critical consideration.

**Return Air Filter**

Air filters must be provided in the return air side of the unit to maintain the efficiency and prolong the operation of the unit. These are also paramount to satisfy requirement for a clean and hygienic room condition. Return Air filters must be placed in an easily accessible location for service and maintenance.

**NOTES**

- Return Air filters are not supplied with the unit as individual air filtration requirements vary.
- Ensure that filters are cleaned / replaced regularly.

**Fan Coil With Vertical Discharge (Optional)**

An upright Fan Coil with vertical supply air discharge is also available wherein installation applications require the placement of the unit down in a closet, basement or garage. Please refer to the Technical Catalogue of your indoor unit for dimensions, installation details and specifications.

**Field Pipe Connections**

Specifications and installation requirements for field pipe connections are contained in the Installation and Commissioning Guide of the outdoor unit that matches your indoor unit. Please refer to this guide and thoroughly understand the procedures for safe and correct indoor and outdoor connection.

**Field Electrical Connection**

The power supply and control communication data to the indoor unit are supplied via the outdoor unit. Please refer to the wiring diagram supplied with the outdoor unit for specifications.

All electrical work must be performed by a licensed electrician and must conform with the wiring diagram and all relevant electrical authorities.

**NOTE**

This indoor unit is designed to match only with an ActronAir Series outdoor unit as specified in the Technical Selection Catalogue.

The unit is supplied with factory charged dry air. Be aware of the pressurised air charge when purging. Remove the caps from the connection points and purge the system only when the field pipe connections are ready to be completed.

## Unit Lifting Instructions

### NOTE

All drawings are for illustration purposes only. Actual unit may vary depending on the model.

### A. CRANE LIFTING METHOD

NOTE: Crane lifting is recommended over fork lift method.

#### EQUIPMENT REQUIRED FOR CRANE LIFTING:

- Spreader bar
- 4 x shackles
- 2 x nylon slings

#### NOTES:

- Refer to catalogue for unit weight before selecting shackles.

#### PROCEDURE:

1. Use 4 x Bow or Dee shackles to connect the lifting holes.
2. Slip nylon slings through all shackles.
3. Ensure slings are protected by rubber pads or similar if slings are draped across unit edges, corners, supply or return air spigots. This will prevent the unit from being damaged during lifting.
4. SPREADER BAR must be used when lifting the unit.
5. Remove all screws and washers that secure the unit to the timber pallet.
6. Remove pallet from the unit. (See pallet removal instructions below).

### PALLET REMOVAL INSTRUCTIONS

#### PROCEDURE:

1. Remove the 14G x 50mm screws (x6) from the pallet
2. Remove Pallet from the unit

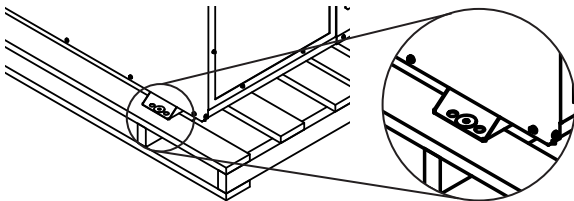

### B. FORK LIFT METHOD

#### NOTES:

Ensure to remove screws and washers only when it is required to disassemble unit from the pallet.  
Do not lift unit using any pipe coming out from the unit  
All dimensions are in mm.

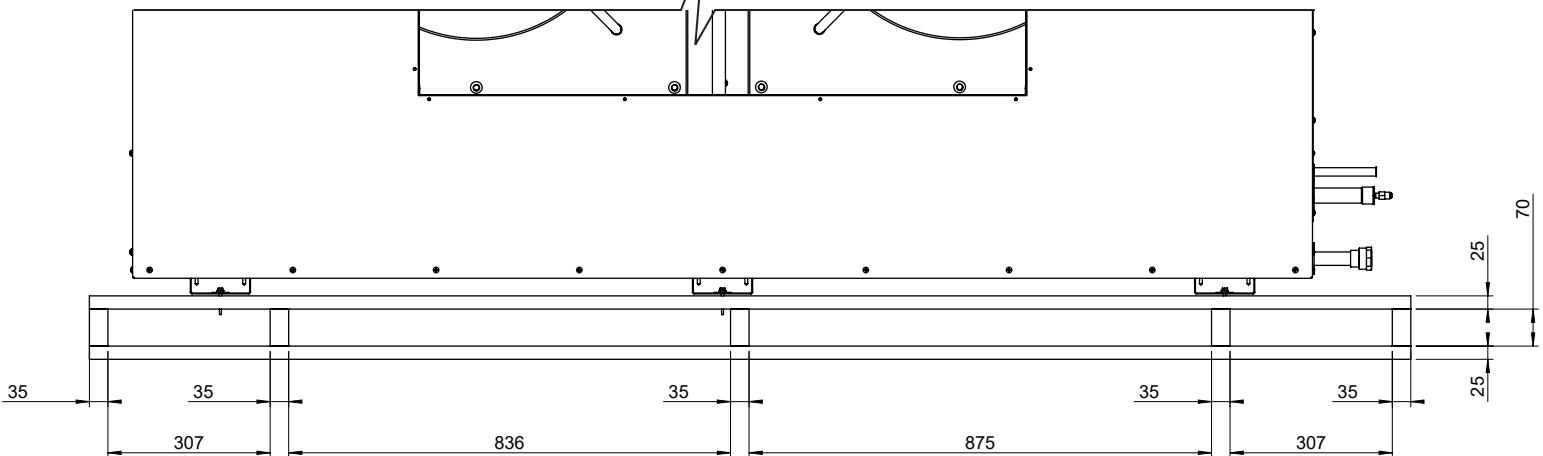

ON THE FRONT AND THE BACK



WH&S regulations must be observed and will take precedent during lifting process.

Connect the loop ends of slings into shackle

#### RUBBER PADS:

Provide rubber pads to prevent damage to the unit if the sling is touching the unit.

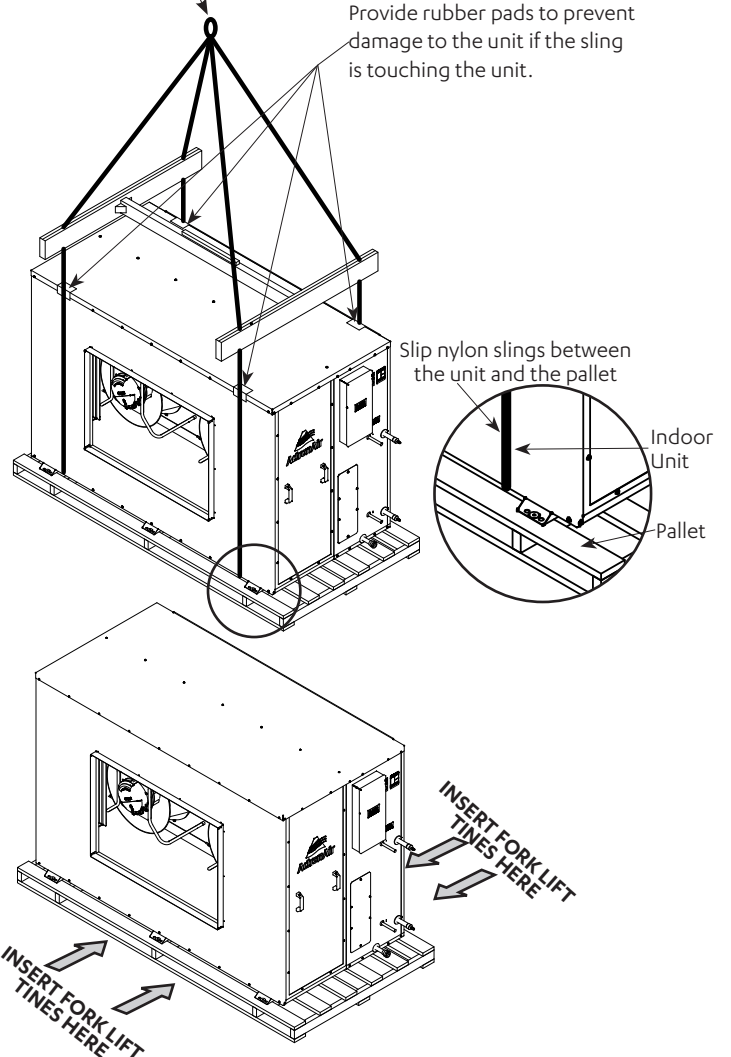

# Condensate Tray Drainage Instructions

## Suggested Minimum Slope to Ensure Correct Drainage

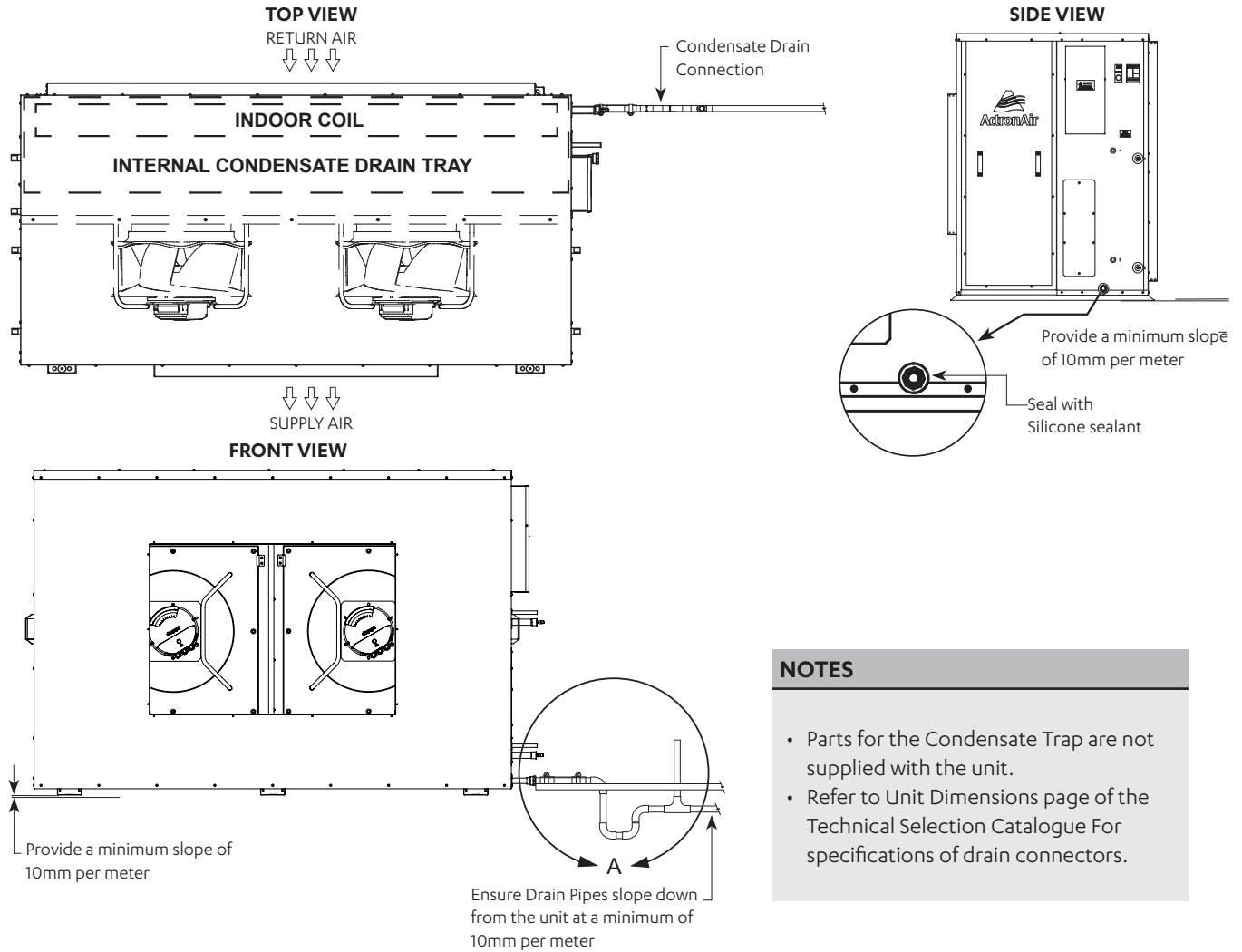

### NOTES

- Parts for the Condensate Trap are not supplied with the unit.
- Refer to Unit Dimensions page of the Technical Selection Catalogue For specifications of drain connectors.

## Suggested Drain Trap Details

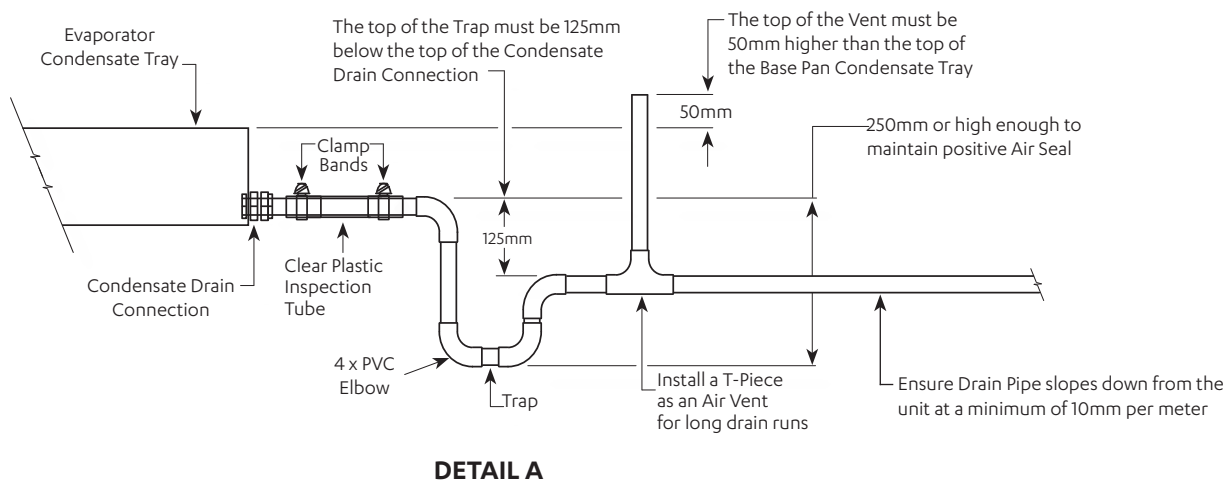

## Electrical Installation

All electrical work must be carried out by a qualified technician. Make sure all wiring is in accordance with local wiring rules. Wiring connections should be made in accordance with the wiring diagram provided.



### DANGER

#### Live Electrical Supply !

- During installation of your air conditioning unit, it may be necessary to work in close proximity to live electricity. Only qualified technicians are allowed to perform these tasks.
- Follow all electrical safety precautions when exposed to live electrical components.
- Always make sure that all power supply, including remote controls, are disconnected before performing maintenance. Observe proper LOCK-OUT / TAG-OUT (LOTO) procedures to ensure that power cannot be inadvertently energised. Failure to disconnect power before maintenance procedure can result in serious injury or death.
- All electrical wiring must be in accordance with the relevant electrical authority rules and regulations.



### CAUTION

#### STATIC SENSITIVE ELECTRONIC DEVICES !

- DO NOT handle electronic devices unless you are wearing an Anti-Static Wrist Strap that is connected to a EARTH. Failure to protect the electronic devices from static electricity may cause unreparable damage.
- Static damaged electronic devices are NOT COVERED for replacement under warranty.

### Wiring Diagram

The wiring diagrams specific for your air conditioning system are located on the inside of the electrical access panel.

Always refer all wiring installation, servicing and troubleshooting of this equipment to this diagram to ensure correct electrical connections are satisfied.

### Supply and Power Requirements Procedure

It is the installer's responsibility to provide power supply wiring to the sub-mains isolator. Wiring should conform to the current electrical authority regulations and all wiring connections to be as per electrical diagram provided with the unit.

- Confirm that the power supply available is compatible with the unit nameplate ratings. The supply power must be within +6% to -6% of the rated voltage as per AS60335.1.
- Protect electrical service from over current and short circuit conditions in accordance with the latest edition of the AS/NZS 3000 "Australian / New Zealand Wiring Rules". Protection devices are to be sized accordingly as per to the electrical specifications of the unit.
- Complete the outdoor unit power supply wiring into the sub-mains isolator.
- Secure the power cords and control cables that enters in/exits out the unit. Use the cable ties provided in the electrical panels.
- Provide proper unit earthing in accordance with local and national wiring rules.

Wiring Diagram 72kW

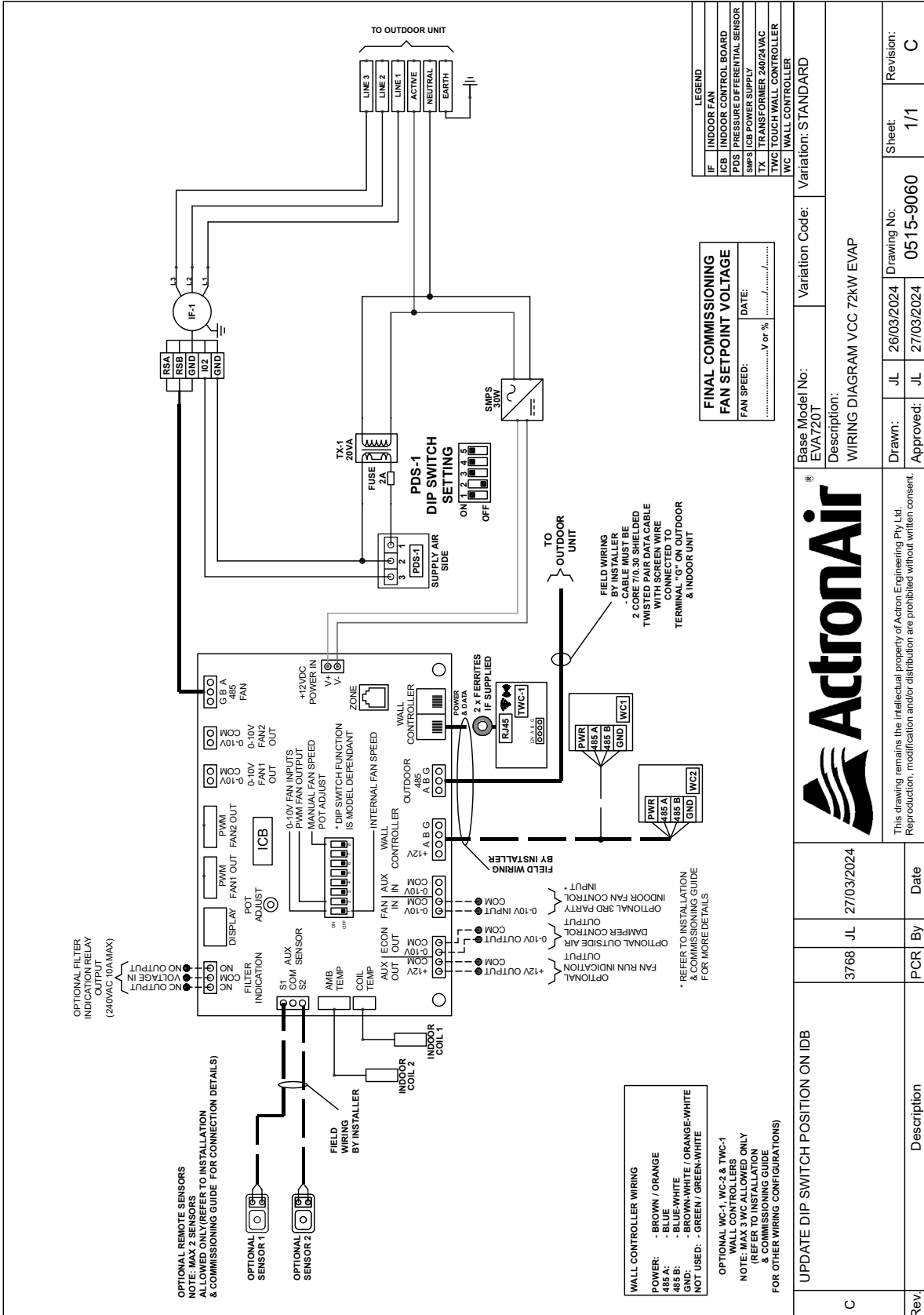

This drawing remains the intellectual property of Actron Engineering Pty Ltd. Reproduction, modification and/or distribution are prohibited without written consent.

3768	JL	27/03/2024	PCR	By	Date
Rev			Description		

Drawn:	JL	26/03/2024	Drawing No:	0515-9060	Sheet:	1/1	Revision:	C
Approved:	JL	27/03/2024						

## Wiring Diagram 85kW

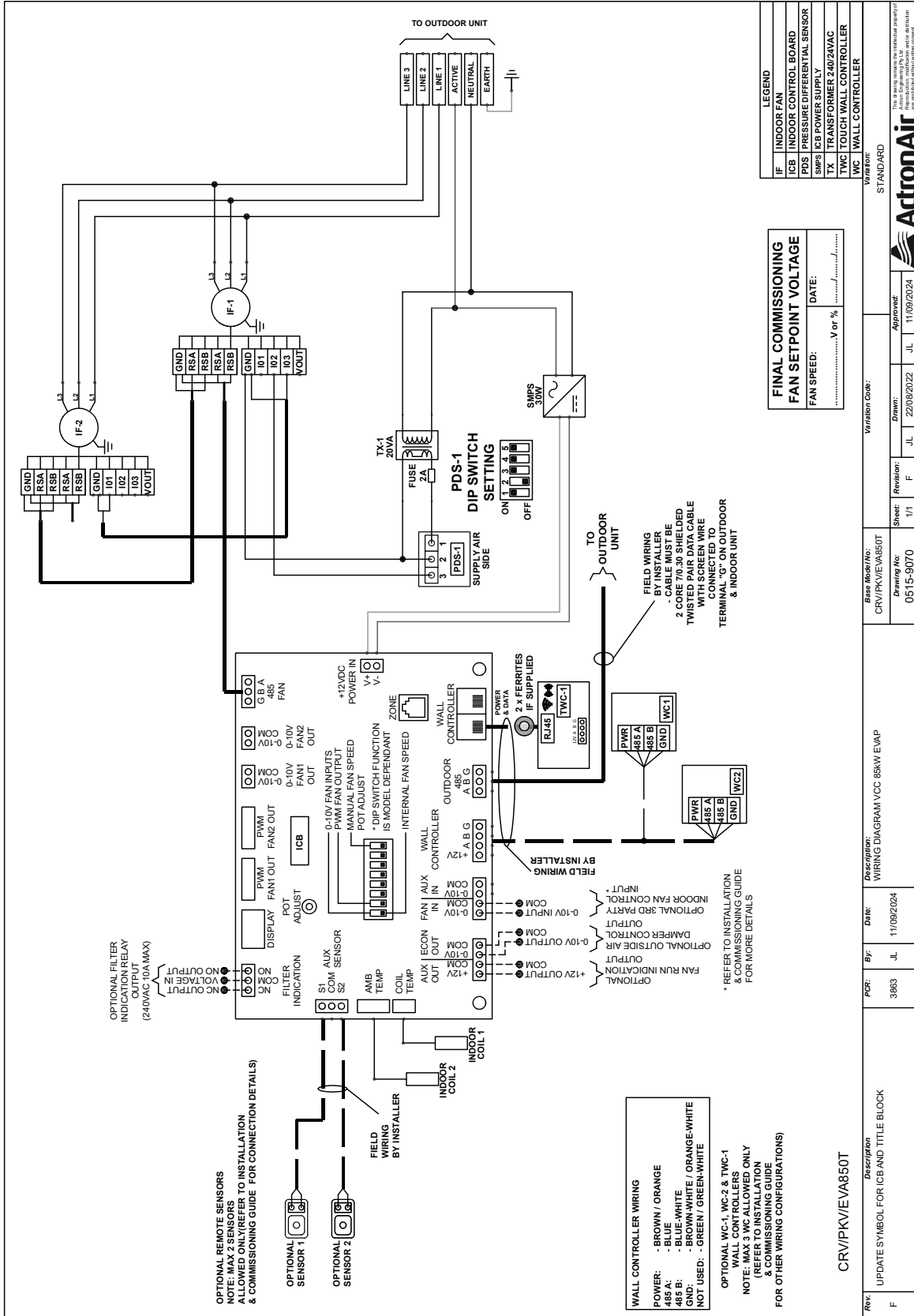

# Wiring Diagram 96kW

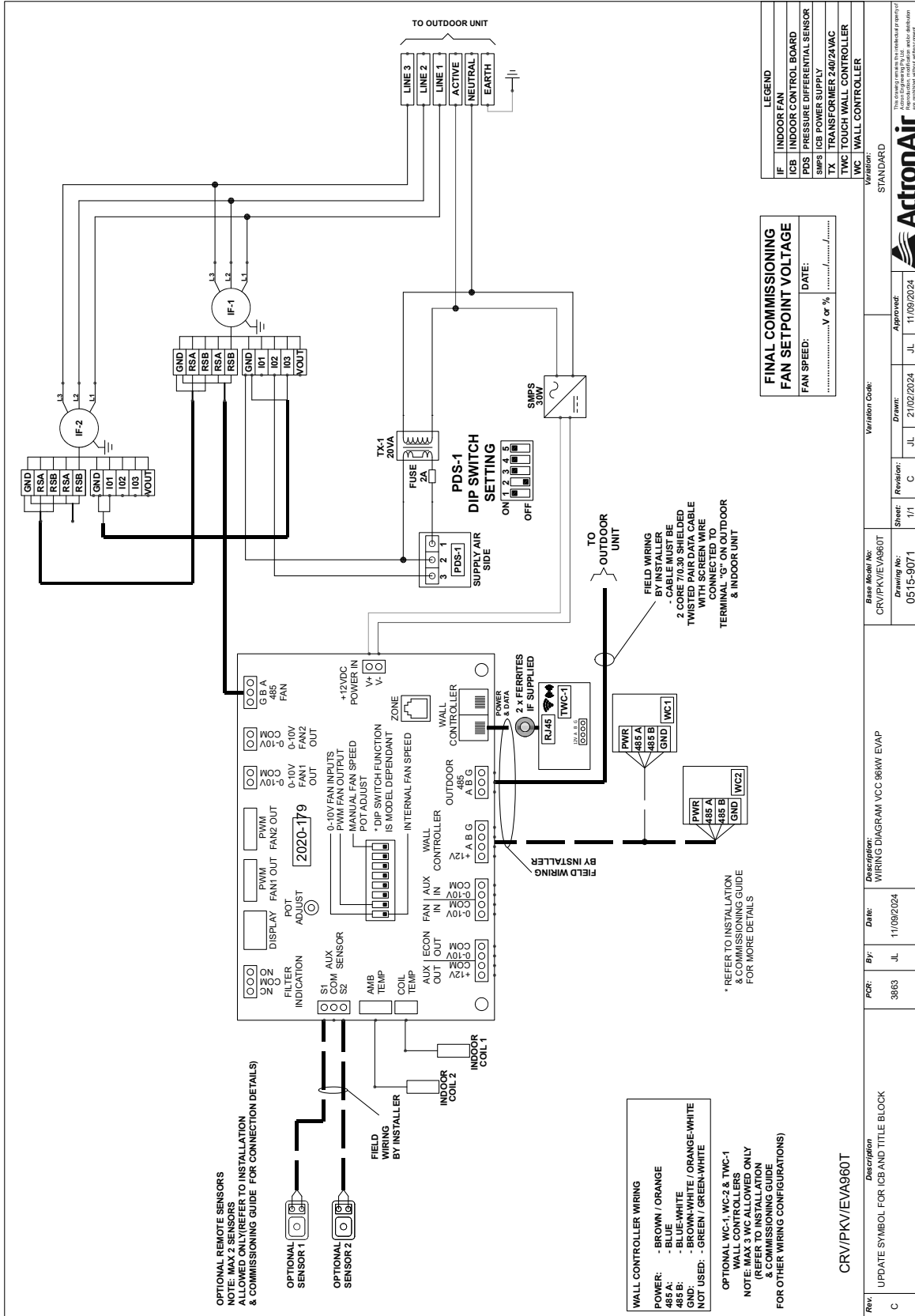



## Electrical Connection

### NOTES

- To minimise noise interference, Data and Power cable clearance should be maintained as much as possible.
- All drawings are for illustration purposes only. Actual unit may vary depending on the model.
- All electrical components do not come with the unit, must be purchased separately.

### DETAILED WIRING DIAGRAM IS PROVIDED WITH THE UNIT.

Outdoor Unit: Located at the back of electrical/compressor access panel.  
 Indoor Unit: Located at the back of electrical box cover.

- ① **MAINS WIRING (400VAC)**  
 (Three Phase + Neutral + Earth) 50Hz
- ② **INTER-CONNECTING POWER CABLE (230/400VAC)**  
 2a (Single Phase + Neutral + Earth) 50Hz  
 2b (Three Phase + Neutral + Earth) 50Hz
- ③ **DATA CABLE TO WALL CONTROLLER**  
 (Cat5E UTP (AWG 24) Data Cable)
- ④ **EXTRA LOW VOLTAGE DATA CONTROL WIRING**  
 (2 Core Shielded Twisted Pair 7/0.30 (0.5mm<sup>2</sup>) Data Cable)

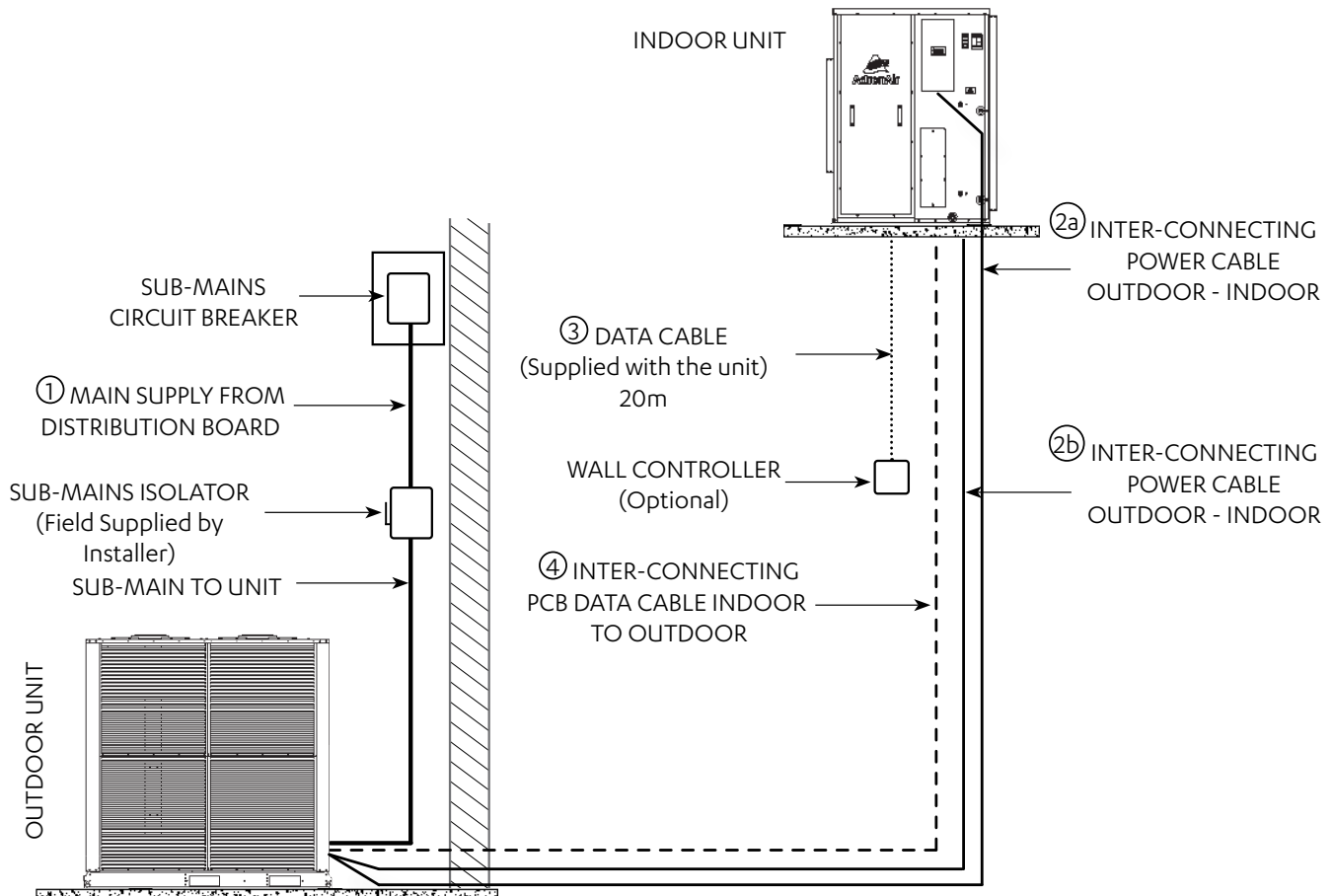

## Data Cable Shielding Instructions

**2 Core Twisted** (ActronAir Part Number: AEDC2)

### NOTES

- Maintain the twist of the core wires up to the Green Terminal Plug.
- Maximum strip length of outer insulation to the Green Terminal Plug is 50mm.
- Make sure the cable colors used for the Data Terminal in Outdoor Unit match the Data Terminal in Indoor unit.

Outdoor Unit Data Terminal (Green Plug)

“Terminal A” - White Wire

“Terminal B” - Black Wire

“Terminal G” - Shield Wire

Indoor Unit Data Terminal (Green Plug)

“Terminal A (+)” - White Wire

“Terminal B (-)” - Black Wire

“Terminal G” - Shield Wire

Insert data cable through the lower snap bushing and first cable tie on the right hand side of the electrical panel.

Connect core wires and shield wire into the Outdoor Board green terminal plug marked “INDOOR A, B and G”.

(Refer to unit wiring diagram for complete wiring connection details).

### NOTE

All drawings are for illustration purposes only. Actual unit may vary depending on the model.

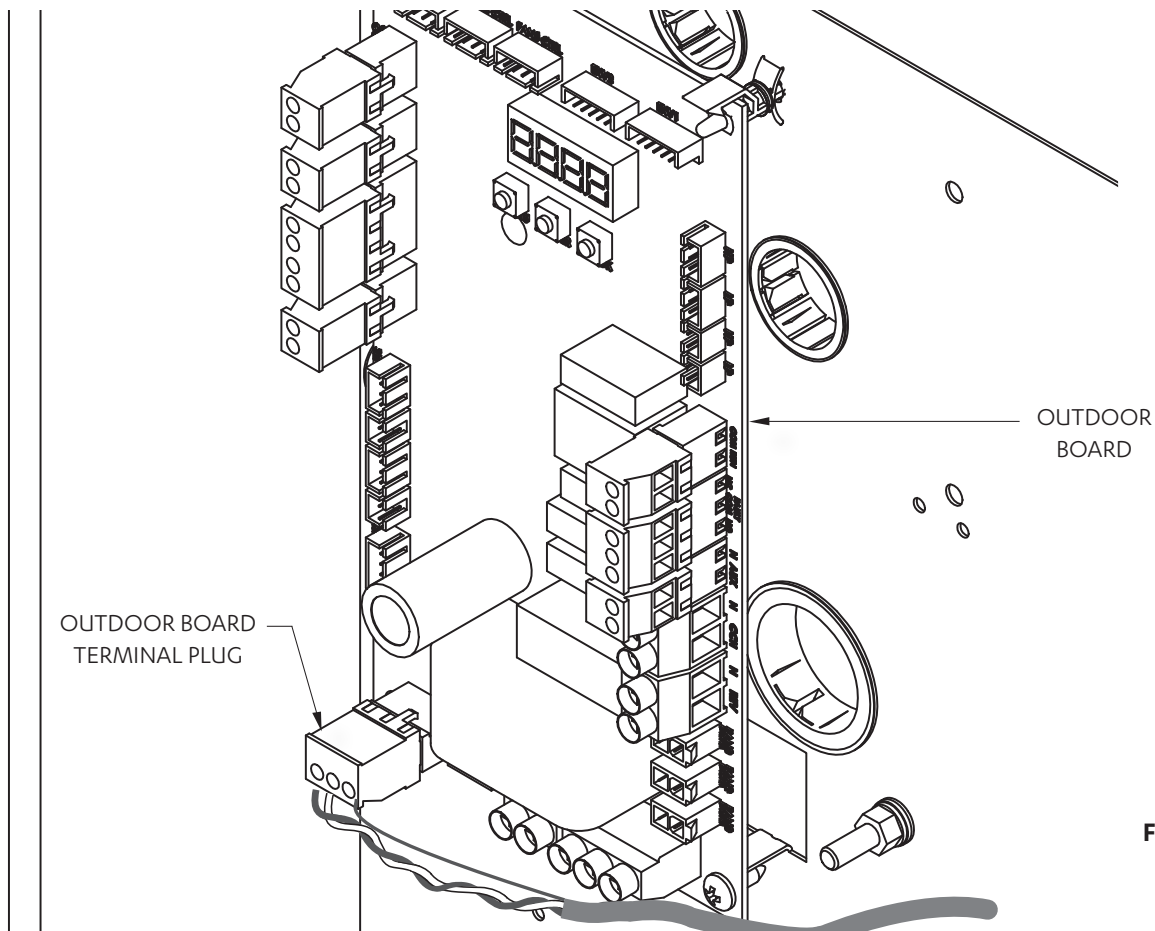

Fig. 3

## Circuit Breaker Size Recommendation

Model	Circuit Breaker Size
	Amps
CRV720T / EVA720T	63
CRV850T / EVA850T	80
CRV960T / EVA960T	80
PKV720T	63
PKV850T	80
PKV960T	80

**Notes:**

Refer to latest edition of AS/NZS 3000 or AS/NZS 3008 Australian/New Zealand Wiring Rules to determine required cable size.

## Wall Controller Options

### Wall Controller Options

A maximum of three (3) wall controllers in the below combinations is allowed per unit. See below table.

Options	Wall Controllers		
	C1	C2	C3
1st Option	NEO		
2nd Option	NEO	NEO	
3rd Option	NEO	NEO	LR7-1 / LC7-2
4th Option	NEO	LR7-1 / LC7-2	
5th Option	NEO	LR7-1 / LC7-2	LR7-1 / LC7-2
6th Option	LR7-1 / LC7-2		
7th Option	LR7-1 / LC7-2	LR7-1 / LC7-2	
8th Option	LR7-1 / LC7-2	LR7-1 / LC7-2	LR7-1 / LC7-2

#### NOTES

- NEO - Available in White (NTW-1000) and Black (NTB-1000).
- LC7-2, LR7-1 and LM-RS-2 - Available in White and Grey.
- In the instance of a combination of NEO and LR7-1 / LC7-2 being connected together, the NEO will always need to be addressed as C1.
- Refer to catalogue for available controller for this product.

## Wiring Configuration : Recommended

### NOTES

- Diagram shown below is a general representation only. Refer to individual unit wiring diagram for complete wiring connection details.
- Long runs beside Mains cables or TV antenna cables should be avoided.
- Wiring configuration for LR7-1 and LC7-2 wall controller is the same.
- Daisy connection is not allowed for the NEO wall controller.
- Two Ferrite Clips\*, if supplied, are to be placed 200mm and 400mm from the NEO controller respectively.

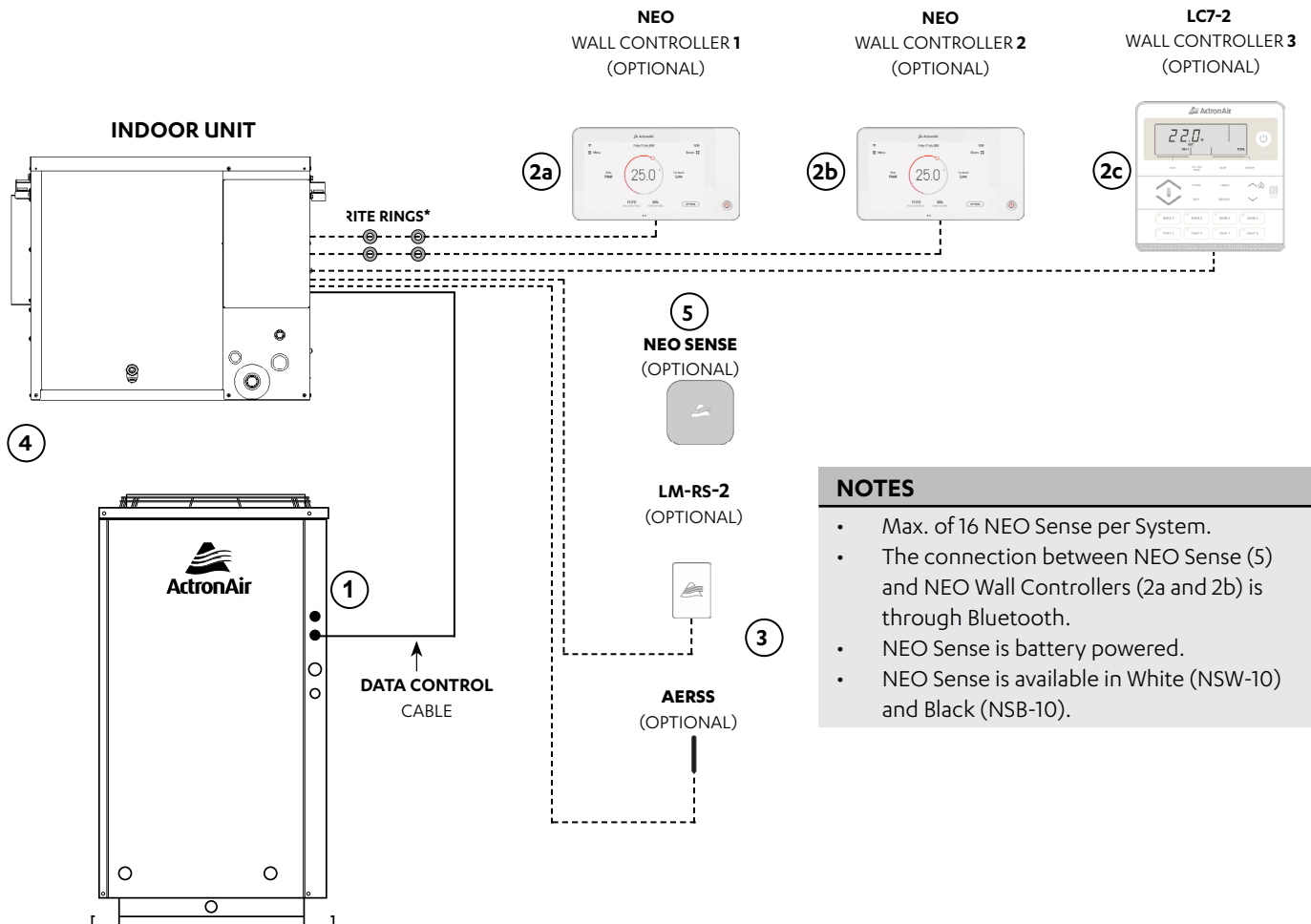

### NOTES

- Max. of 16 NEO Sense per System.
- The connection between NEO Sense (5) and NEO Wall Controllers (2a and 2b) is through Bluetooth.
- NEO Sense is battery powered.
- NEO Sense is available in White (NSW-10) and Black (NSB-10).

### Split System

Item	Description	Maximum Cable Length
1 to 4	Outdoor PCB to Indoor PCB	100 m
4 to 2a, 4 to 2b	Indoor PCB to Wall Controller	90 m
4 to 2c	Indoor PCB to Wall Controller 3	100 m
4 to 3	Indoor PCB to Remote Sensor	100 m
4 to 5	Indoor PCB to ZC and ZS	100 m

Description	Cable Type
Indoor to Wall Controller	Cat5e UTP (AWG 24) Data Cable
Indoor to Remote Sensor	Cat5e UTP (AWG 24) Data Cable
Indoor to Outdoor Data Cable	2 Core (1 Pair) Twisted Pair, 7/0.30 (0.5mm <sup>2</sup> ) Shielded Data Cable

**Wiring Configuration : Alternate**

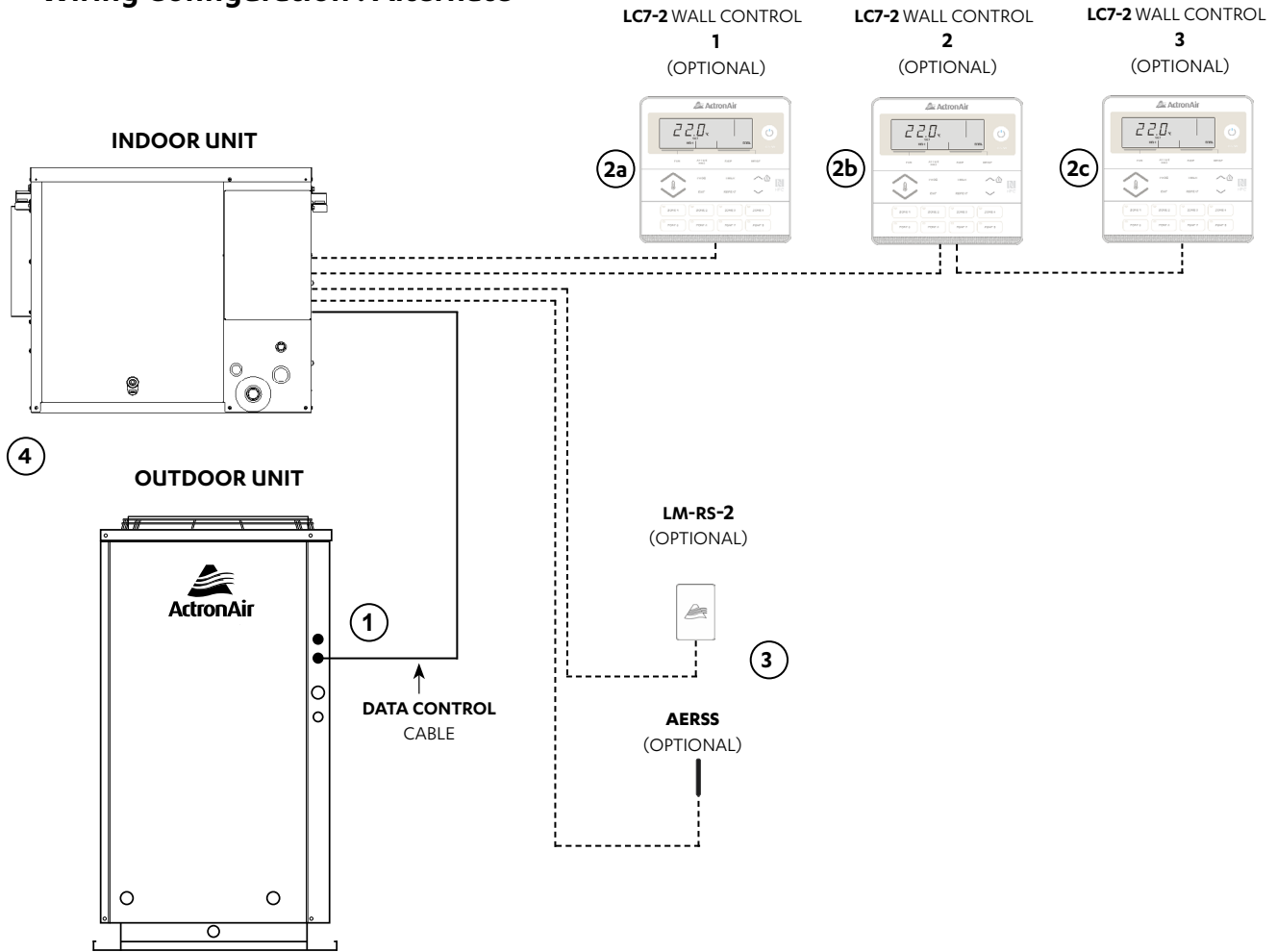

**NOTES**

- Diagram shown above is a general representation only. Refer to individual unit wiring diagram for complete wiring connection details.
- Long runs beside Mains cables or TV antenna cables should be avoided where possible.
- Wiring configuration for LR7-1 and LC7-2 wall controller is the same.

**Split System**

Item	Description	Maximum Cable Length
1 to 4	Outdoor PCB to Indoor PCB	100 m
4 to 2a	Indoor PCB to Wall Controller 1	100 m
4 to 2c	Indoor PCB to Wall Controller 3 (last controller)	75m total (Daisy Chain)**
4 to 3	Indoor PCB to Remote Sensor	100 m

\*\* Maximum Daisy Chain connection is up to 2 wall Controls.

Description	Cable Type
LR7-1 Field Control Wiring	Cat5e UTP (AWG 24) Data Cable
Indoor to Remote Sensor	Cat5e UTP (AWG 24) Data Cable
Indoor to Outdoor Data Cable	2 Core (1 Pair) Twisted Pair, 7/0.30 (0.5mm2) Shielded Data Cable

**Wiring Connections**

**LR7-1 and LC7-2 Wall Control Wiring Connections**

**WALL CONTROL WIRING**

- POWER: - BROWN / ORANGE
- 485 A: - BLUE
- 485 B: - BLUE-WHITE
- GND: - BROWN-WHITE / ORANGE-WHITE
- NOT USED: - GREEN / GREEN-WHITE

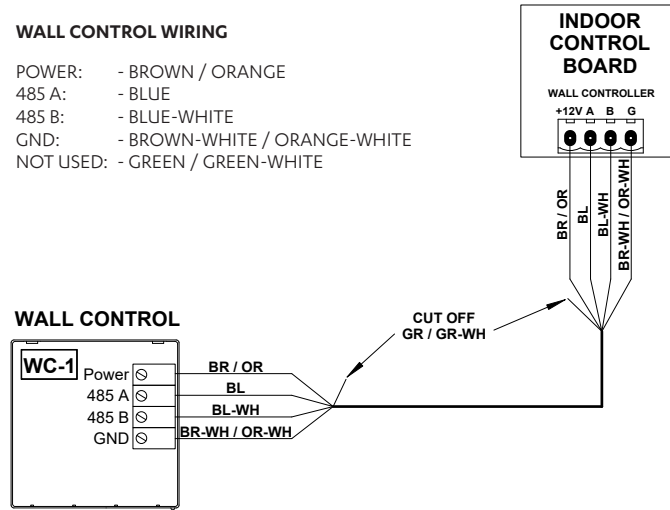

**NEO Wall Control Wiring Connections**

**NOTES**

Two FERRITE CLIPS, if supplied, should be installed 200 mm away and FERRITE 2 should be 400 mm away from the Wall Control.

**NEO Hard Wiring**

**WALL CONTROL WIRING**

- POWER: - BROWN / ORANGE
- 485 A: - BLUE
- 485 B: - BLUE-WHITE
- GND: - BROWN-WHITE / ORANGE-WHITE
- NOT USED: - GREEN / GREEN-WHITE

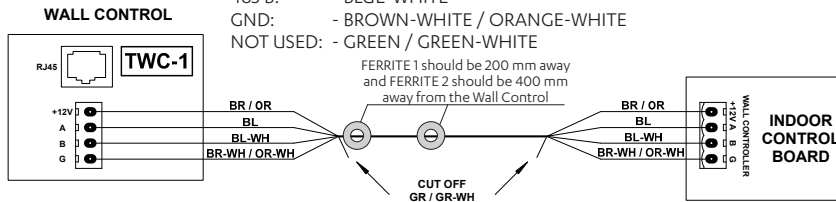

**NEO RJ45 Wiring**

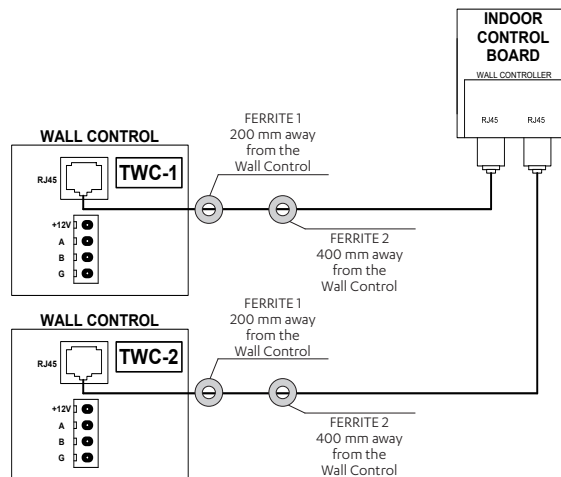

### LM-RS-2 Optional Sensor Wiring Connections

**REMOTE SENSOR WIRING**

- PAIR 1: - BLUE / BLUE-WHITE
- PAIR 2: - ORANGE / ORANGE-WHITE
- PAIR 3: - GREEN / GREEN-WHITE
- PAIR 4: - BROWN / BROWN-WHITE

**NOTE:**

- PAIR 1 AND 2 USED FOR ILLUSTRATION PURPOSES ONLY.
- CUT OFF AND TERMINATE ANY UNUSED PAIRS TO ENSURE NO WIRING IS LEFT EXPOSED.

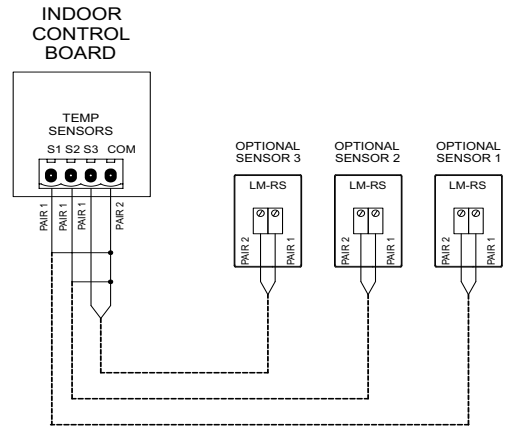

### AERSS Optional Duct Sensor Wiring Connections

**REMOTE SENSOR WIRING**

- PAIR 1: - BLUE / BLUE-WHITE
- PAIR 2: - ORANGE / ORANGE-WHITE
- PAIR 3: - GREEN / GREEN-WHITE
- PAIR 4: - BROWN / BROWN-WHITE

**NOTE:**

- PAIR 1 AND 2 USED FOR ILLUSTRATION PURPOSES ONLY.
- CUT OFF AND TERMINATE ANY UNUSED PAIRS TO ENSURE NO WIRING IS LEFT EXPOSED.

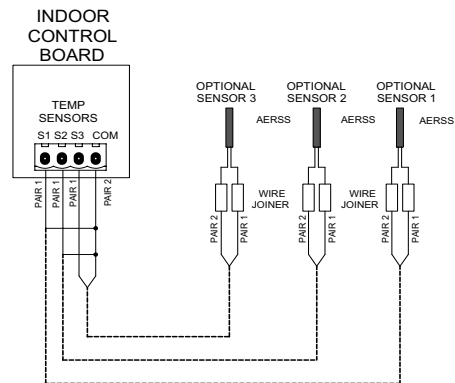



## Accessing Service and Technical via NEO

Special options are available via Advance Option menu. This must be accessed through Service and Technical section. Follow the steps as shown below:

1. To access the Menu, touch on the hamburger icon (☰) on the NEO Controller.

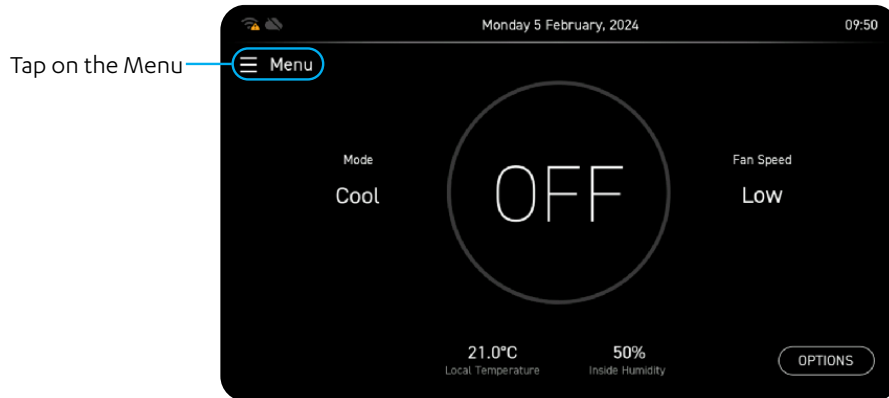

2. On the Main Menu, Select the **Service & Technical** Section.

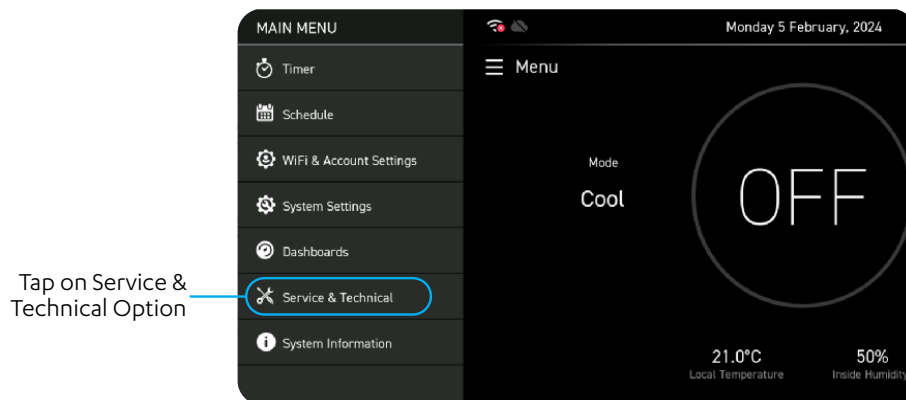

3. An Access Code will be asked. Provide Access Code - **7378**

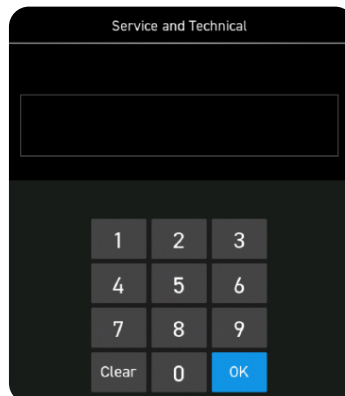

4. The **Service & Technical** Section screen is as below:

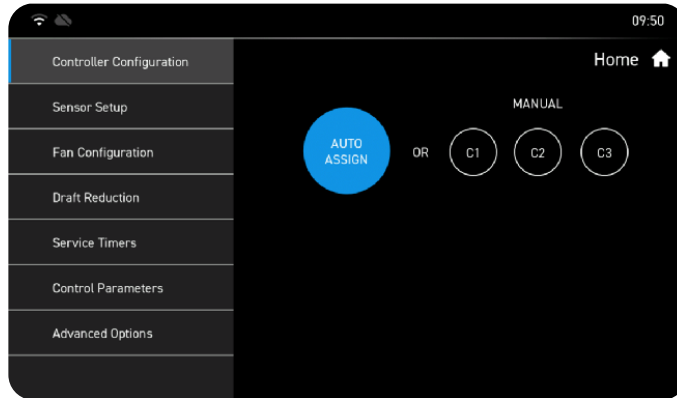

## After Hours Logic with Timeclock (Scheduler)

After Hours is the duration (in minutes) in which the unit will turn ON when the After Hours is set. By default, this is set to 0 min. The Minimum Settable Value is 1 min and the Maximum Settable Value is 120 mins. Setting this will be accessible via Service & Technical menu.

Set up the After Hours via the Control Interface as follow:

1. In the **Service and Technical** Section, select the **Advanced Options**.

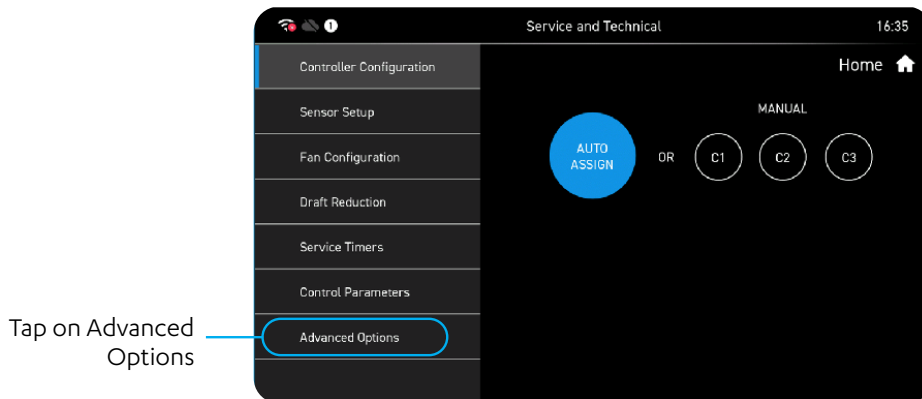

2. In the Advanced Options, select **Enable Commercial Application Mode** by tapping on the check box.

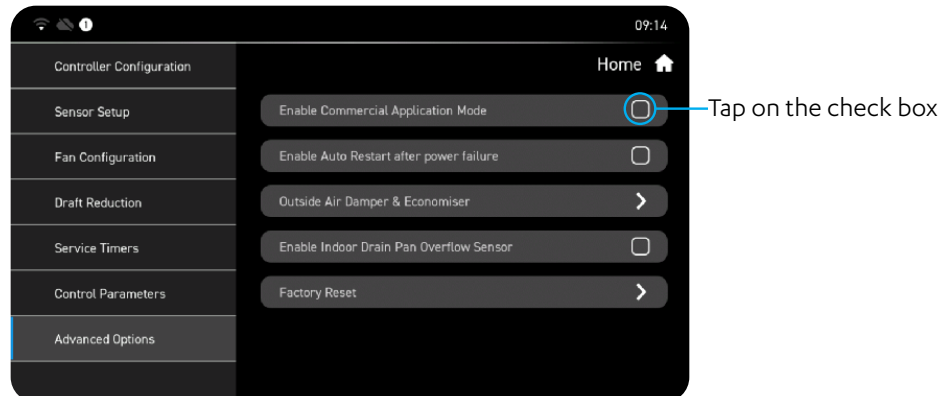

3. Touch on the **Options** tab to get to the next slide.

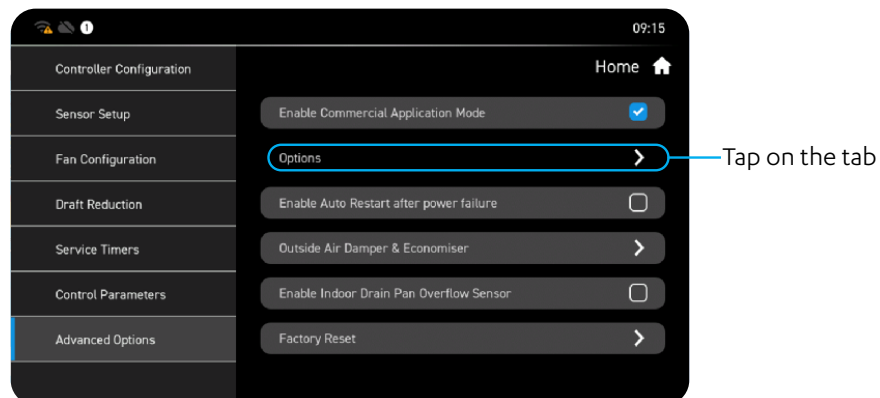

4. Activate the **After Hours Mode** by tapping on the check box.

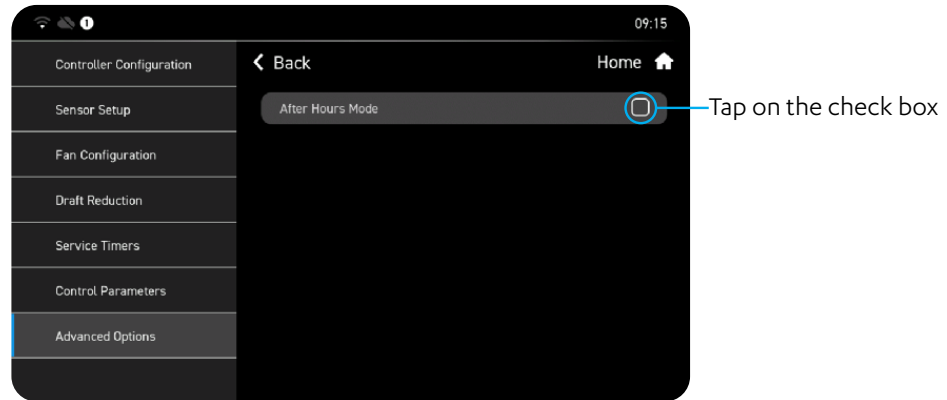

5. Make necessary changes as the settings will be automatically saved. Touch on the **Home** button on the top right corner to go back to the **Home** screen.

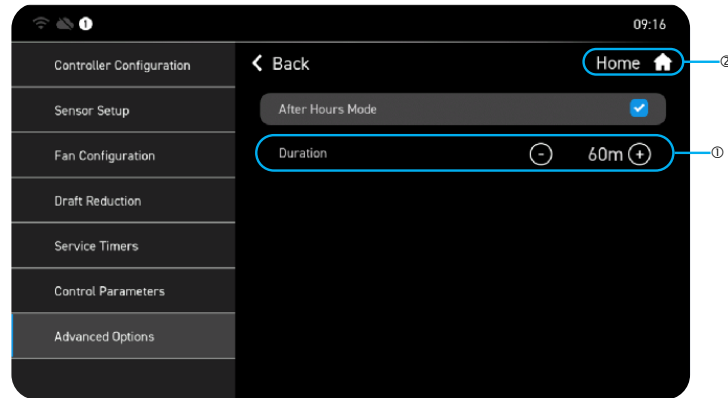

6. **Home** screen.

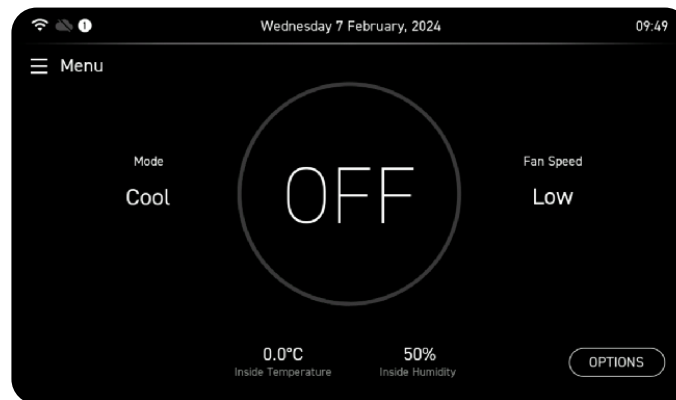

7. To view the new setting of the **After Hours Mode**, touch the **Menu** button on the **Home** screen.

Tap on the Menu

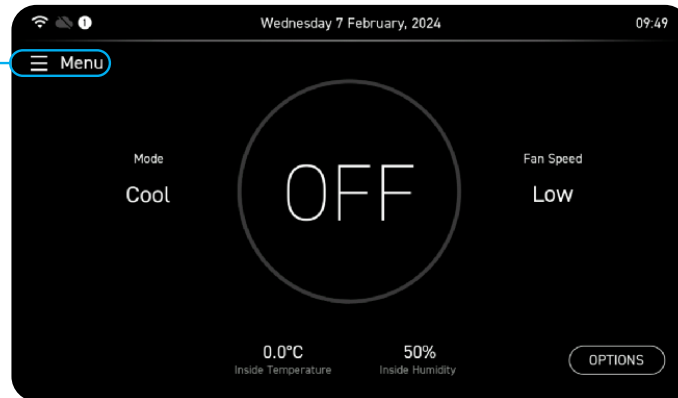

8. Select the **After Hours** and the new settings will appear.

Tap on After Hours

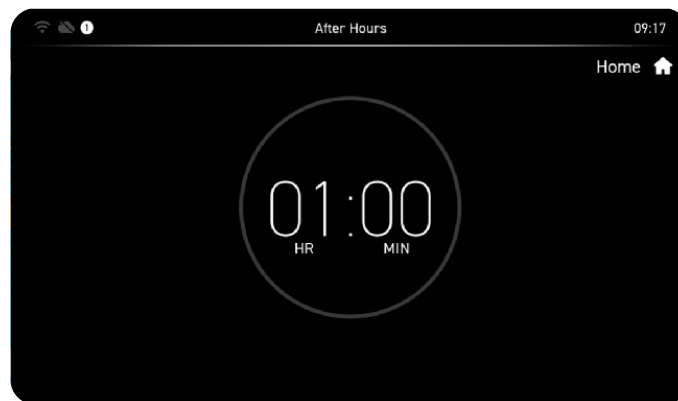
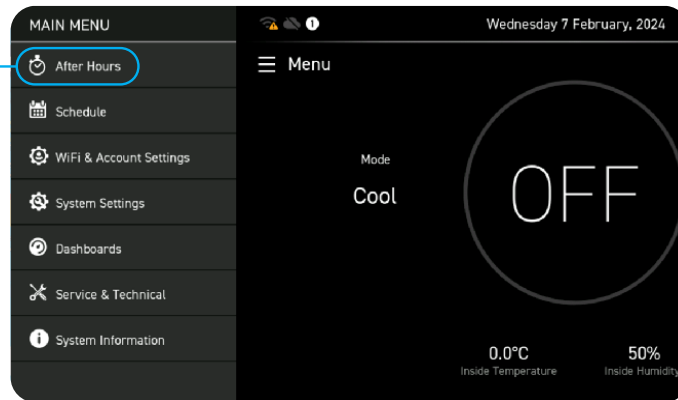

## Filter Alarm Configuration

This gives the user an option to Enable and set the Air Filter Alarm .  
The setting is accessible via Service & Technical menu.

### Filter Alarm Configuration

The filter timer can be set via the Control Interface as follow:

1. In the **Service & Technical** Section, select the **Service Timers**.

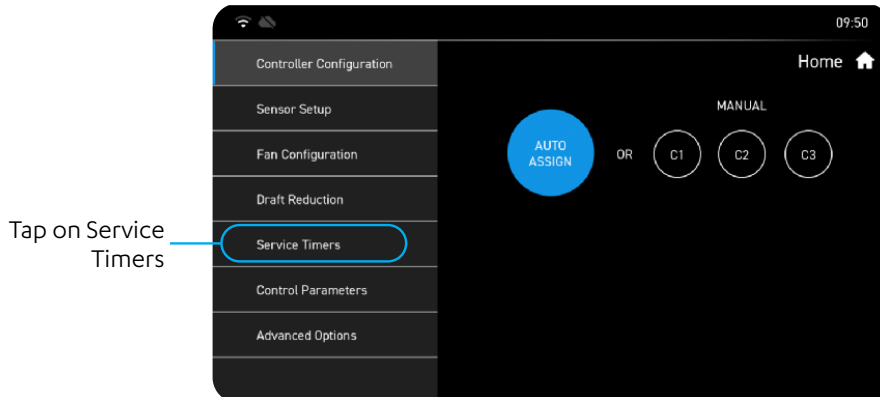

2. In the Service Timers, select **Fan Filter Alarm Configuration** by tapping on the tab

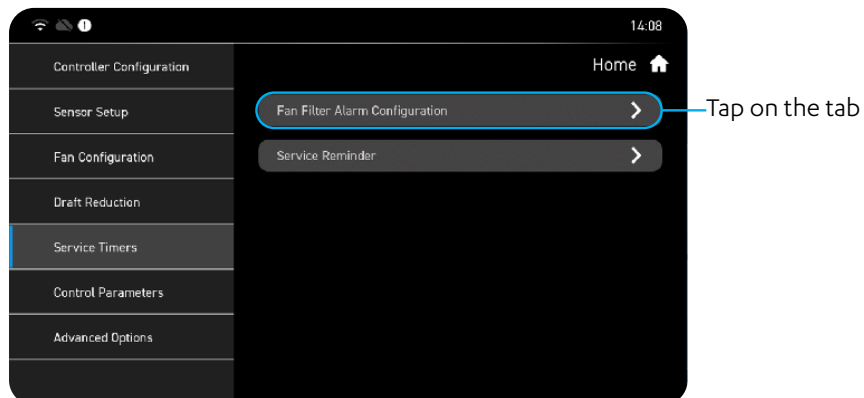

3. Make sure the **Timer Mode** is ticked. Make necessary changes on the **Duration** by clicking the (-) or (+) buttons. Settings are automatically saved.

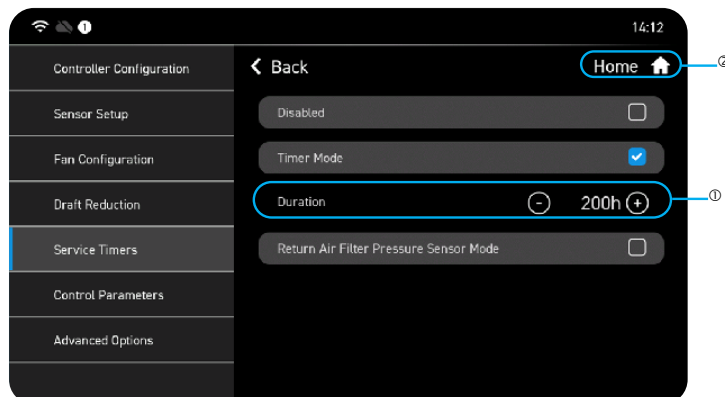

4. Click on the **Home** button on the top right corner to go back to the home screen.

## Indoor Drain Pan Overflow Sensor

In a typical air conditioning setup, the drain pan serves a vital function by gathering and expelling water from the unit. This pan is typically linked to gravity-fed drain traps, commonly referred to as P-traps. These P-traps need to be carefully designed to match the specific negative pressure of the application to ensure proper functionality and effective drainage of condensate from the unit.

However, neglecting regular servicing and maintenance of P-traps can result in blockages. When this occurs, the drain pan may also become obstructed, causing water to overflow from the unit and potentially infiltrate the building through the roof structure.

To avert such incidents, integrating an overflow sensor into the system proves beneficial. This sensor detects and prevents any potential overflow or water leakage, enhancing the system's security and dependability. By incorporating an overflow sensor, you can ensure the safe and efficient operation of your system while minimizing the risk of water damage that could lead to costly repairs.

### Location of the Indoor Drain Pan Overflow Sensor:

The Indoor Drain Pan Overflow Sensor is an optional feature, and its availability depends on the selected unit option. If this feature was opted, the sensor will be pre-installed in the drain pan near the indoor heat exchanger as shown in the diagram below.

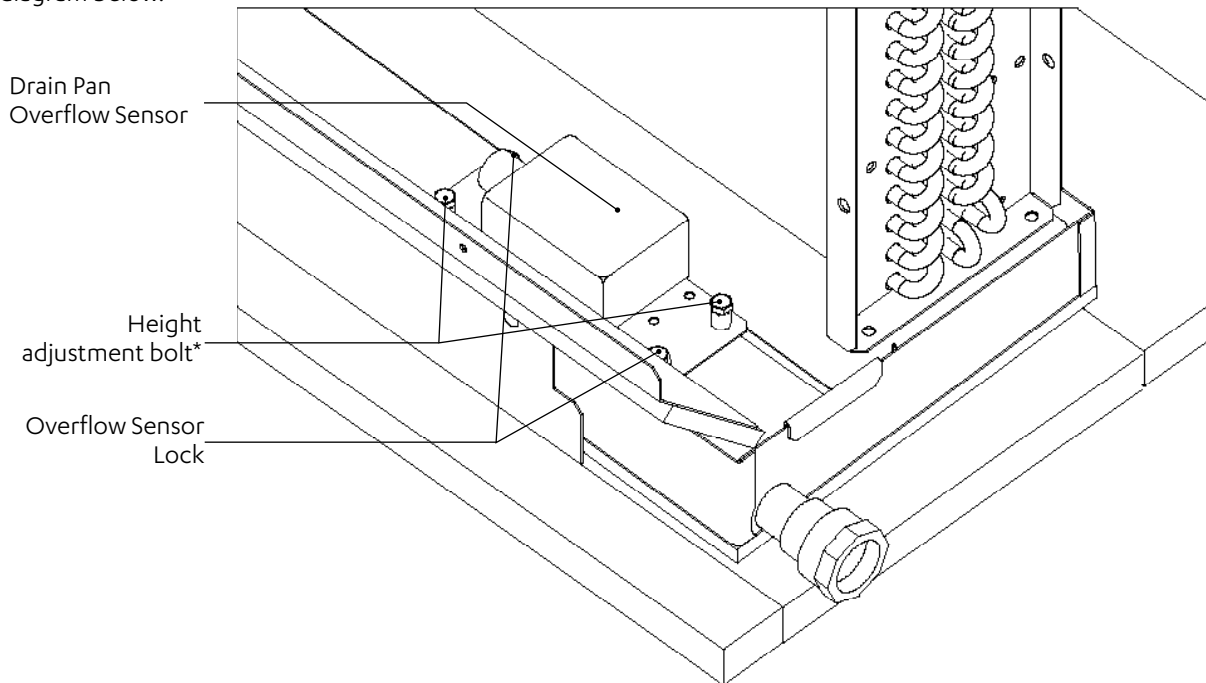

\* May be used to adjust the height of the sensor for maintenance purposes

### Enable the Indoor Drain Pan Overflow Sensor via the Control Interface as follow:

1. In the **Service and Technical** Section, select the **Advanced Options**.

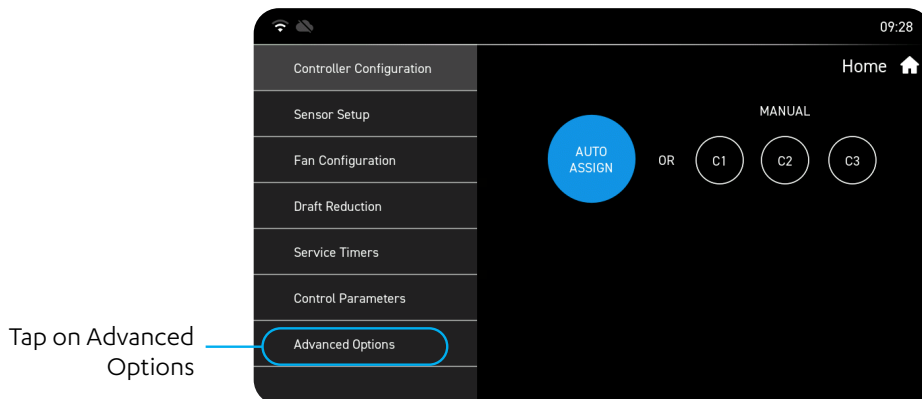

- In the Advanced Options, select **Enable Indoor Drain Pan Overflow Sensor** by tapping on the check box.

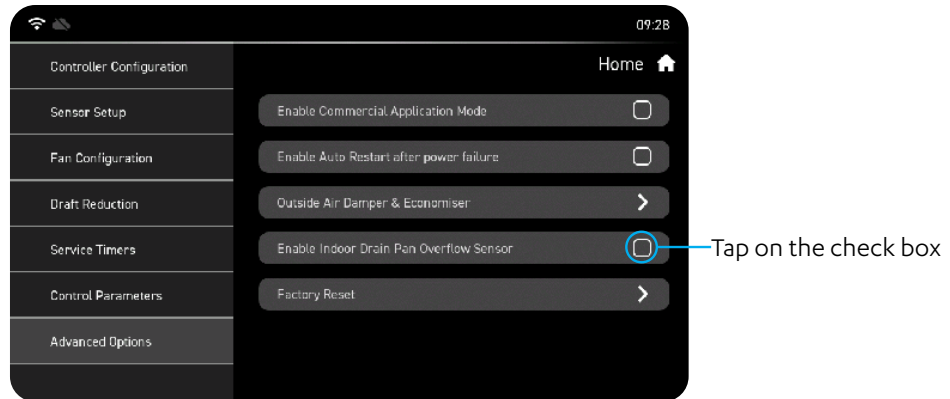

- Touch on the **Home** button on the top right corner to go back to the home screen.

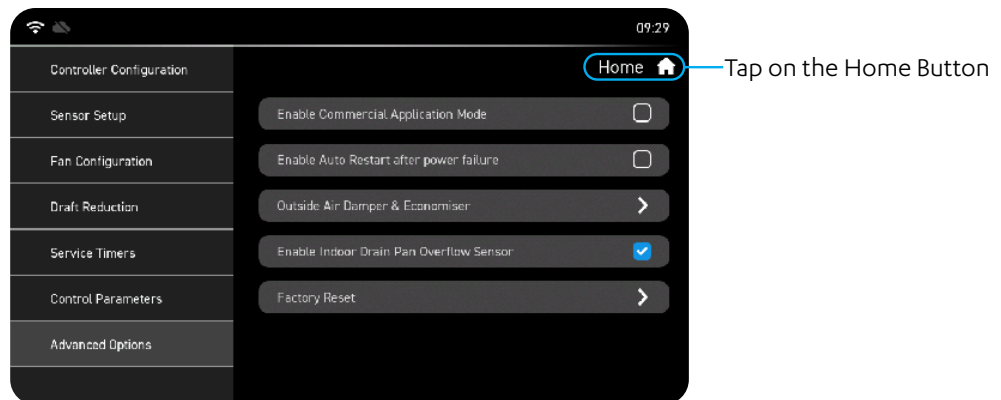
**NOTE**

- When the Overflow Sensor feature is activated, the system will continuously monitor the status of the sensor.
- If no sensor trigger occurs, the system will continue to operate normally. However, if a trigger occurs, the system will automatically display a fault code, and the compressors will cease operation while the indoor fan continues to operate.
- If the unit stops working, it is recommended to check the P-trap and clean it if it is clogged. Once the water level goes down, the system will take 3 minutes to automatically reset the error code. If the issue persists, it is suggested to inspect the overflow sensor as per the wiring diagram or get in touch with ActronAir support team at **1300 522 722**.



## Maintenance

### Maintenance Procedures

This section describes the procedures that must be performed as a part of normal maintenance program. Regular servicing of equipment by licensed technician is highly recommended. Regular servicing of your unit helps in maintaining its optimum performance and reliability. **The checklist and service periods provided on this manual are guides only, as some sites may require more frequent servicing.** Always disconnect electrical power to the unit before performing these procedures unless otherwise required. It is always a safe practice to observe all safety warnings and cautions when conducting maintenance tasks.



#### DANGER

##### Live Electrical Connections!

It may be necessary to work with live electrical components on certain maintenance tasks. Only licensed electricians and qualified technicians are allowed to perform these tasks.

##### Beware of Rotating Fan Blades!

Always make sure that all power supplied to the fans are turned Off and isolated.

Observe WH&S safety procedures, do not wear loose clothing and any jewellery when working near the fans.

Wear PPE whenever performing any maintenance procedures.

Observe all necessary procedures when working on a confined space.



#### WARNING

##### Hazardous Voltage!

Always make sure that all power supply, including remote controls, are disconnected before performing maintenance.

Observe proper LOCK-OUT/TAG-OUT procedures to ensure that power cannot be inadvertently energised. Failure to disconnect power before maintenance procedures can result in serious injury and/or death.

EC Motors are fitted with high power capacitors and can have dangerous residual voltages at motor terminals after power has been isolated. Wait at least 5 minutes after power isolation and test for any residual voltage before beginning service work.

### Annual Maintenance Checklists

- Perform general maintenance inspections.
- Perform scheduled start-up checks.
- Leak test refrigerant circuits.
- Inspect contacts of all contactors and relays. Replace all worn contacts as required.
- Inspect, clean and tighten all electrical connections.
- Check fans for balanced operation. Make sure that there are no loose screws / bolts, no fan blades interference and no damage to the fans and guards.
- Inspect the air filters, clean or replace as required.
- Clean and repaint any corroded panel section.
- Ensure no blockage of airflow through variable speed drive.

### Cleaning the Condenser Coils

Clean the coils at least once a year or more frequently if unit is located in a dusty and dirty environment, in order to maintain your system's proper operating performance. High discharge pressures are good indication that the coils need cleaning. When using detergent or solvents to clean the coils, follow the manufacturer's instructions to avoid potential damage to the coils and to the unit.

To clean the refrigerant coils, use a soft brush and water spray, such as garden hose or pressure washer with low pressure nozzle.

 **WARNING****Do Not Use High Alkaline Detergent!**

When using detergent for coil cleaning, ensure that the alkaline level is no higher than 8.5, which can cause corrosion damage to the coils.

 **DANGER****No Water into the Electrical Compartments!**

Ensure consideration is given to the possibility of water entering the electrical compartments during cleaning of the condenser coil.

**Coil Cleaning Procedure**

- Disconnect power to the unit.
- Remove the louvered panels from the unit to gain access to the air inlet side of the coils.
- Use a soft brush to remove loose dirt and debris from both sides of the coils.
- Straighten bent coil fins with fin comb.
- Prepare the detergent solutions according to the manufacturer's instructions.
- Spray solution at a 90° angle to the coils, keeping a minimum nozzle spray angle of 15°, with at least a 1800mm distance from the coils and 600 psi pressure.
- Spray leaving air side of the coils first then the air inlet side. Allow the solution to stand on the coils for five minutes.
- Rinse both sides of the coils with cool clean water.
- Inspect the coils, if they are still dirty, repeat the cleaning procedure.
- Clean and wipe dry the outer and inner sides of the unit, the refrigerating parts and other components.
- Ensure that the condensate drain lines are not blocked.
- Reinstall all unit panels, covers and guards.
- Restore electrical power to the unit.

## Maintenance Frequency Checklist

Regular servicing of equipment by a qualified technician is recommended every 12 months for residential applications and every quarter for commercial applications. Regular servicing of your unit helps in maintaining its optimum performance and reliability. **The following checklist and service periods are provided as a guide only, as some sites may require more frequent servicing.**

ELECTRICAL											
Parts	Service Period					Detail of Service Check	Service Methods				
	1 Mth	3 Mth	6 Mth	1 Yr	2 Yrs			3 Yrs	4 Yrs	5 Yrs	
Printed Circuit Boards				✓						Visual Inspection	Tighten Terminals as necessary on printed circuit boards
Electrical Connections				✓						Check all electrical terminals, mains, communications, etc	Re-tighten if loose.

INDOOR UNIT											
Parts	Service Period					Detail of Service Check	Service Methods				
	1 Mth	3 Mth	6 Mth	1 Yr	2 Yrs			3 Yrs	4 Yrs	5 Yrs	
Casing / Panels and Frames				✓						Visual check for damage, rust and dust accumulation.	For highly corrosive environment, wash panels quarterly with water and neutral detergent solution. Wax panels. Repair / re-paint where required.
Insulation				✓						Visual check for insulation conditions.	Repair / replace insulation material.
Fan				✓						Visual check for run out of balance and dust attached	Clean off dust as necessary to negate possibility of fan running out of balance
Motor				✓ Ω						Visual check on wiring. Insulation resistance check to be carried out annually	Measure insulation resistance. Reading should be more than 1MΩ.
Heat Exchanger				✓						Check for clogging by dust. Check for leaks / damage.	Clean air inlet side as necessary. Straighten any bent fins using fins comb.
Drain Pan/ Condensation line				✓						Check for obstructions and free flow of water	Clean to eliminate obstructions/ sludge and check condition of pan. Pour water to ensure flow
Filter*		✓								Check for clogging by dust.	Clean Filter
Temperature Readings				✓						Measure air on and air off	Place temperature probe in return and supply air of unit.
Damper Motors (if fitted)				✓						Visual inspection of motors open/closing. Ensure no obstructions	Drive motors opened and closed. Ensure correct operation
Duct Works				✓						Inspect duct works for air gaps.	Re-tape any loose ducts.

\* Service period for filter cleaning may vary depending on operating time and surrounding environment.

### Start Up and Commissioning Report

INSTALLATION INFORMATION	
CUSTOMER	Name: _____ Tel. Number: _____
	Address: _____
INSTALLER	Name: _____ Tel. Number: _____
	Address: _____
Site Address: _____	Date Installed: _____
Model: _____	Serial Number: _____

CIRCUIT TEMPERATURE SETTINGS	
Supply Air Temperature	_____ °C
Return Air Temperature	_____ °C
Suction Temperature	_____ °C
Discharge Temperature	_____ °C
Condenser Coil Temperature	_____ °C
Ambient Temperature	_____ °C

INDOOR FAN SETTINGS		OUTDOOR FAN SETTINGS	
Indoor Fan Current	_____ Amps	Outdoor Fan Current	_____ Amps
Indoor Fan Airflow	_____ l / s		
Indoor Fan PWM	_____ %		
Set Static	_____ Pa		

Check No Active Error Codes on the Unit	Checked: <input type="checkbox"/>
---	-----------------------------------

Date Checked:	_____
---------------	-------

## Version History

DOCUMENT VERSION	BOM VERSION	UPDATE HISTORY
Ver 1	-0100	Released
Ver 2	-0100	Included lower capacity models
Ver 3	-0100	Phase 2
Ver 4	-0100	Included Neo Wall Controller Options
Ver 5	-0100	Added Safety Precautions Information; Updated Wiring Diagrams; Replaced AS60038 with AS60335.1



©Copyright 2022 Actron Engineering Pty Limited ABN 34 002767240. ®Registered Trade Marks of Actron Engineering Pty Limited. ActronAir is constantly seeking ways to improve the design of its products. Therefore, specifications are subject to change without notice.