

VARIABLE CAPACITY COMMERCIAL

72 - 96kW Outdoor (R-410A Series)

Installation and Commissioning Guide



Model Numbers

CRV720T
CRV850T
CRV960T

IMPORTANT NOTE:

Please read this manual carefully before installing or operating your air conditioning unit.



Table of Contents

Introduction	4
General Information	5
Safety Instructions	7
Installation Information	8
Operation Manual Access	9
Unit Mounting and Location	10
Components Overview	11
Electrical Control Panel	12
CRV720T	12
CRV850T / CRV960T	13
Group Control Option Electrical Board Layout	14
BMS Option Electrical Board Layout	15
Unit Dimensions, Clearances and Weights	16
CRV720T	16
CRV850T/ CRV960T	17
Service Clearances, Airflow Allowances and Weights	18
Unit Lifting Procedure	19
Crane Lifting Method	19
Fork Lift Method	19
Banking of Outdoor Units	20
End-To-End Configuration	20
Cluster Configuration	20
Side-By-Side Configuration	20
Condensate Drainage Instructions	21
Suggested Minimum Slope to Ensure Correct Drainage	21
Suggested Drain Trap Details	22
Outdoor Unit Preparation	23
Field Pipe Connection	24
Piping and Brazing	24
Interconnecting Pipe Run Recommendation	24
Pressure Testing	27
Evacuation Procedure (Triple Evacuation)	28
Specifications for Refrigeration	29
Electrical Installation	30
Electrical Connection	31
Data Cable Shielding Instructions	32
Circuit Breaker Size Recommendation	33
Wall Controller Options	34
Wall Controller Options	34
Wiring Configuration : Recommended	35
Wiring Connections	37

Table of Contents

LR7-1 and LC7-2 Wall Control Wiring Connections	37
NEO Wall Control Wiring Connections	37
LM-RS-2 Optional Sensor Wiring Connections	38
AERSS Optional Duct Sensor Wiring Connections	38
Wiring Diagram 72kW	39
Wiring Diagram 85kW	40
Wiring Diagram 96kW	41
Configuring and Commissioning Setup	42
Menu and Navigation	42
Configuring Compressor and Capacity(cnFg)	43
Configuring Control Source (CtrS)	43
Optional BMS Control	44
Accessing Service and Technical via NEO	45
After Hours Logic with Timeclock (Scheduler)	47
Filter Alarm Configuration	50
Filter Alarm Configuration	50
Bluetooth Commissioning Tool	51
Demand Response Management	52
Third Party Control Input (Indoor and/or Outdoor Board)	53
0-10V Analogue Input for Compressor and Indoor Fan	53
0-10V Analogue Input for Compressor with Fixed Indoor Fan Speed	54
Input for Fixed Compressor with Fixed Indoor Fan Speed	55
0-10V Analogue Input for Indoor Fan with Fixed Speed Compressor	55
Run and Fault Indication Output (Outdoor Board)	56
Remote On/Off	57
Fan Performance Data and Curve	58
EVA720T	58
EVA850T	60
EVA960T	62
Sensor Detail	64
Refrigerant Charging	65
Charging Method: Subcooling and Superheat	65
Fault Display Codes	69
Outdoor Board Fault Display Codes	69
Maintenance	72
Maintenance Frequency Checklist	74
Start Up and Commissioning Report	75
Version History	76

Introduction

CONGRATULATIONS on your purchase of an ActronAir air conditioning system! This unit has been designed and engineered to provide optimum air conditioning and to achieve maximum energy efficiency.

Your air conditioning system has been manufactured from the highest quality materials. Numerous “in house” and “external” inspection and test procedures were conducted to your air conditioner to ensure satisfactory operation.

Information About This Guide

This guide provides installation instructions, specific to your ducted unit. Read this manual thoroughly and take into consideration all specifications and instructions to ensure correct installation and safe operation of your air conditioning system.

NOTE

Print a copy of this document and keep it for future reference. Ensure all technicians that work on the unit can refer to this manual at any time.

Product Inspections

Check your air conditioning unit and all items against the invoice upon receiving your shipment. Inspect the unit, components and accessories for any sign of damage. If there is any damage to the unit, contact ActronAir Customer Care Department immediately on: **1300 522 722** to obtain a Goods Return Number.

Check the unit nameplate to verify the model, serial number, electrical rated specifications are correct.

Codes, Regulations And Standards

The installer and/or contractor assumes responsibility to ensure that unit installation complies with the relevant council, state / federal codes, regulations and building code standards. All electrical wiring must be in accordance with current electrical authority regulations and all wiring connections to be as per electrical diagram provided with the unit

General Information

ActronAir air conditioning units are designed for applications where superior performance, high efficiency, reliability, supply air quality and quiet operation are the prime priorities. The units are built with the latest technologies advanced variable speed driven inverter compressor, EC outdoor/indoor fans, low-noise outdoor fans, electronic expansion valve and an intelligent electronic control.

For optimum efficiency, your air conditioning unit will deliver just the right amount of cooling or heating capacity.

Energy Efficient Refrigeration Circuits

The ActronAir system is designed with a highly efficient refrigeration circuit that delivers only the amount of cooling or heating actually required to maintain your desired comfort at the most optimum efficiency.

Each refrigeration circuit consists of:

- High efficiency variable capacity scroll compressor with individual compressor drive
- Hydrophilic coated condenser coil designed for optimum performance and efficiency with corrugated fins and ruffled tubing
- Hydrophilic coated evaporator coil designed for optimum performance and efficiency with lanced fins and ruffled tubing
- Electronic expansion valve (EEV), to maintain efficiency at across a wide range of operating conditions

Evaporator Section

The evaporator section has EC fans which deliver just the right amount of airflow, depending on requirements. The fans provide superior performance for your comfort at optimum efficiency:

- Highly efficient variable speed EC motor that uses less energy than the traditional fixed speed induction motor
- Easy indoor fan commissioning via intelligent controllers
- Low noise operation
- Adjustable Indoor Airflow

Condenser Section

Uses two (2) EC axial fans and state of the art Inverter Compressor, with the following features:

- Efficient Tru-Inverter Compressor and Inverter Drive combination
- Efficient axial fans with direct drive EC motor
- Low noise operation
- Variable compressor capacity
- Variable speed outdoor fan

Electrical Section

The electrical section is composed of a panel for controls, protecting the components from the elements and a separate panel enclosure for the variable speed drive.

Durable Design and Construction

ActronAir is an Australian manufacturer with proven high quality air conditioning products. Known for their durability and reliable performance, these products are designed and built to withstand the extreme Australian weather conditions.

The galvanized steel cabinet, with powder coated epoxy enamel finish, resists the toughest conditions. The louvered outdoor coil guard protects the condenser coil from any potential damage brought by hail, stones and other solid objects that may be projected to the unit.

Blue Hydrophilic coil fins provide protection to your heat exchangers and enhanced heat transfer with increased performance efficiency.

External fasteners in all Outdoor and Package unit are stainless steel screws Gem-Cote coating.

System Flexibility

The ActronAir Variable Capacity range air conditioning units are the first choice for residential and commercial applications, both for new construction or retrofitting projects.

Refrigerant Handling and Accountability

ActronAir strongly urges that all service technicians make every effort possible to eliminate and/or vigorously reduce the emission of refrigerants to the atmosphere. Everyone must act in a responsible manner to conserve refrigerants in accordance to the industry code of practice.

Sustainability and Environmentally Friendly

The air conditioning system is supplied with zero ozone depleting refrigerant, which has no phase out or replacement concern.

With cooling and heating performance capacity that are among the best in the market, the ActronAir air conditioning units provide the solution for the reduction of energy consumption, CO₂ emission, high fuel dependency and high network grid demand.

Safety Instructions

- Only licensed HVAC technicians* should install and service air conditioning equipment. Improper service or alteration by an unqualified technician could result in significant and major damage to the product or property which may render your warranty null and void. Such unqualified service could also lead to severe physical injury or death. Follow all safety instructions in this literature and all warning labels that are attached to the equipment.
- Prevailing WH&S regulations must be observed and will take precedence to the safety instructions contained on this manual. Safe work practices and environment must be the paramount importance in the performance of all the service procedures.
- Ensure that unit installation complies with relevant council regulations and building code standards.
- All electrical wiring must be in accordance with current electrical authority regulations and all wiring connections to be as per electrical diagram provided.
- Secure the fans against accidental contact. Beware of pinch point and sharp edges which can cause cutting injury.
- Always wear appropriate PPE, remove any dangling jewelery and protect long hair by wearing a cap.
- Make sure that safety guards and panel covers are always firmly secured and not damaged before and during operation of unit.
- This appliance is not intended for use by young children or infirm persons unless they have been adequately supervised by a responsible person to ensure that they can use the appliance safely. Young children should be supervised to ensure that they do not play with the appliance.
- Installer must incorporate a means of electrical disconnection (isolator) in the sub mains fixed wiring in accordance with the latest edition of the AS/NZS 3000 (also known as Australian Wiring Rules).
- Secure the power cords and control cables that goes in/out the unit. Use the cable ties provided in the control box.
- This unit is designed for use with R-410A refrigerant only.

*Qualifications required will be appropriate Electrical, Refrigeration and Refrigerant Handling License and Training dependent on local State/Territory regulations.

DANGER

Hazardous Voltage - Risk of Electrocutation.

TURN-OFF the power from main isolator before proceeding with any service work of the unit. Observe proper LOCK-OUT/TAG-OUT (LOTO) procedures for electrical appliances in order to prevent accidental switching-on of the power supply.

WARNING

EC Motors and Compressor Drives are fitted with high power capacitors and can have dangerous residual voltages at motor/drive terminals after power has been isolated. Wait at least 5 minutes after power isolation and test for any residual voltage before beginning service work.

CAUTION

Beware of Rotating Fans !

Ensure that indoor and outdoor fans are isolated and have come to a complete stand still before servicing the equipment. Beware of pinch point and sharp edges which can cause cutting injury. Secure the fans against accidental contact. Always wear appropriate PPE and remove any dangling jewellery and protect long hair by wearing a cap. Ensure that no loose clothing can be caught / entangled in moving parts.

VISUAL INSPECTION AND WORK ASSESSMENT

Work areas and conditions must first be assessed and evaluated for any potential hazardous conditions. It is also important to be familiar with the unit parts and components before proceeding with any service task.

Installation Information

All service technicians handling refrigerant must be licensed to handle refrigerant gases.

Recover and Recycle Refrigerants

Never release refrigerant to the atmosphere! It is an offence in Australia to do so. Always recover, recycle and reuse refrigerants. When removing from the system, properly contain and identify refrigerants in its dedicated container for proper disposal and/or storage. Always consider the recycle or reclaim requirements of the refrigerant before beginning the recovery procedures. Obtain a chemical analysis of the refrigerant if necessary. For the recovered refrigerant and acceptable refrigerant quality, refer to the existing standards and regulations.

Refrigerant Handling and Safety

Consult the refrigerant manufacturer's Material Safety Data Sheet (MSDS) for information on proper handling and to fully understand health, safety, storage and disposal requirements. Use the approved containment vessels and refer to appropriate safety standards. Comply with all applicable transportation standards when shipping refrigerant containers.

Service Equipment and Recovery Procedures

Always use refrigerant reclaiming equipment in order to minimise refrigerant emissions. Use equipment and methods which will pull the lowest possible system vacuum while recovering and condensing refrigerant. Equipment capable of pulling a vacuum of less than 500 microns is required.

Do not open the system to the atmosphere for service work until refrigerant is fully removed and/or recovered. Perform refrigeration system evacuation, prior to charging, in accordance with AIRAH / IRHACE Refrigerant handling code of practice.

Let the unit stand for 1 hour and with the vacuum not rising above 500 microns. A rise above 500 microns indicates a leak from the system and a leak test is required to locate and repair any leak.

CAUTION

A leak test is always required on any repaired section of the refrigeration system.

Charge refrigerant into the system only after the equipment does not leak or contain moisture. Take into consideration the correct amount of refrigerant charge specified for the system to ensure efficient unit operations. When charging is complete, reclaim refrigerant from charging lines into an approved refrigerant container. Seal all used refrigerant containers with approved closure devices to prevent unused refrigerant from escaping to the atmosphere. Take extra care to maintain all service equipment directly supporting refrigerant service work such as gauges, hoses, vacuum pumps and recycling equipment.

INSTALLATION PREPARATION (Pre-Installation considerations)

The following items must be considered before beginning the unit installation:

- Verify the unit capacities and ratings with the unit nameplate.
- Make certain the floor or foundation is level, solid and has sufficient structural strength to support the unit and accessories weight.
- Allow minimum recommended clearances for periodic maintenance and service access.
- Allow sufficient space above the unit for the outdoor air discharge. Condenser air inlet, located on the coil side of the unit, requires sufficient airflow clearance for the optimum unit performance.
- Note the conditioned supply air and return air location. Ensure sufficient spaces are allocated for these purposes.
- For the connection and location of condensate drain in the unit, refer to the drawings and dimensions section of this manual.
- Wiring connections must be in accordance with the wiring diagram provided with the unit.
- Make sure all wirings are in accordance with local electricity authority regulations and standards.
- Do not install the unit close to an area where there is a danger of fire due to volatile, explosive, flammable and/or hazardous materials.
- Ensure that spaces around the unit are free from any obstructions for optimum unit performance.

- Installer to ensure correct size/type that main circuit breaker and cable is installed in unit sub-mains to protect the sub-mains and unit wiring.
- Installer to ensure correctly rated residual current device (RCD) is installed as per the latest edition of the AS/NZS 3000 (also known as Australian Wiring Rules).
- Secure the power cords and control cables that goes in/out the unit. Use the cable ties provided in the control box.

 **CAUTION**

This outdoor unit is designed to match only with an ActronAir indoor unit as specified in the Technical Selection Catalogue. The unit is supplied with factory charged refrigerant as stated in the Rating Label. The use other material as a refrigerant may cause explosion and/or personal injury.

Be aware of all the relevant regulations concerning the handling of refrigerant.

For units charged with R-410A

Ensure that R-410A is only charged in liquid form.

For units charged with R-32

R-32 refrigerant (CLASS A2L) is mildly flammable.

Thoroughly read and understand the accompanying R-32 Safety Guide for installation and maintenance instructions.

Installation, service, maintenance, repairs and decommissioning of this unit must be performed by a licensed HVAC technician; qualified to handle R-32 refrigerant.

Appliance shall be installed, operated and stored in a well ventilated area:

- where the room size corresponds to the room area as specific for operation.
- without continuously operating open flames (for example an operating gas appliance) and ignition sources (for example an operating electric heater).
- away from other potential continuously operating sources that known to cause ignition of R-32 refrigerant.

R-32 refrigerant is odorless if the refrigerant gas comes into contact with fire, it may emit a poisonous gas.

Operation Manual Access

Download from Website

Operation Manuals can be downloaded through our websites shown below.

<https://actronair.com.au/manuals/>

Unit Mounting and Location

1. The units must be installed in accordance with relevant authority regulations.
2. Install the unit on a level and strong foundation.
3. Install anti-vibration rubber or isolation mounts (installer to supply) under **all of the unit's feet** to help reduce noise and minimize vibration transfer through the foundation. Ensure that all anti-vibration rubbers are rated to provide stable support without impairing the unit's structural integrity.
4. Diameter or width of anti-vibration rubber's must be at least equal to the width of the actual feet to prevent deformation overtime.
5. Level the unit to ensure good condensate drainage away from the unit.
6. Ample service access areas and minimum space allowance for airflow must be provided.
7. Avoid installing the unit in such a place where there is danger of fire due to leakage of inflammable fluid.
8. Ensure that the spaces around the unit are free from any obstructions for optimum unit performance.

Components Overview

NOTES:

Drawing is subject to change without notice.
 Drawing for illustration purposes only (may vary depending on capacity)

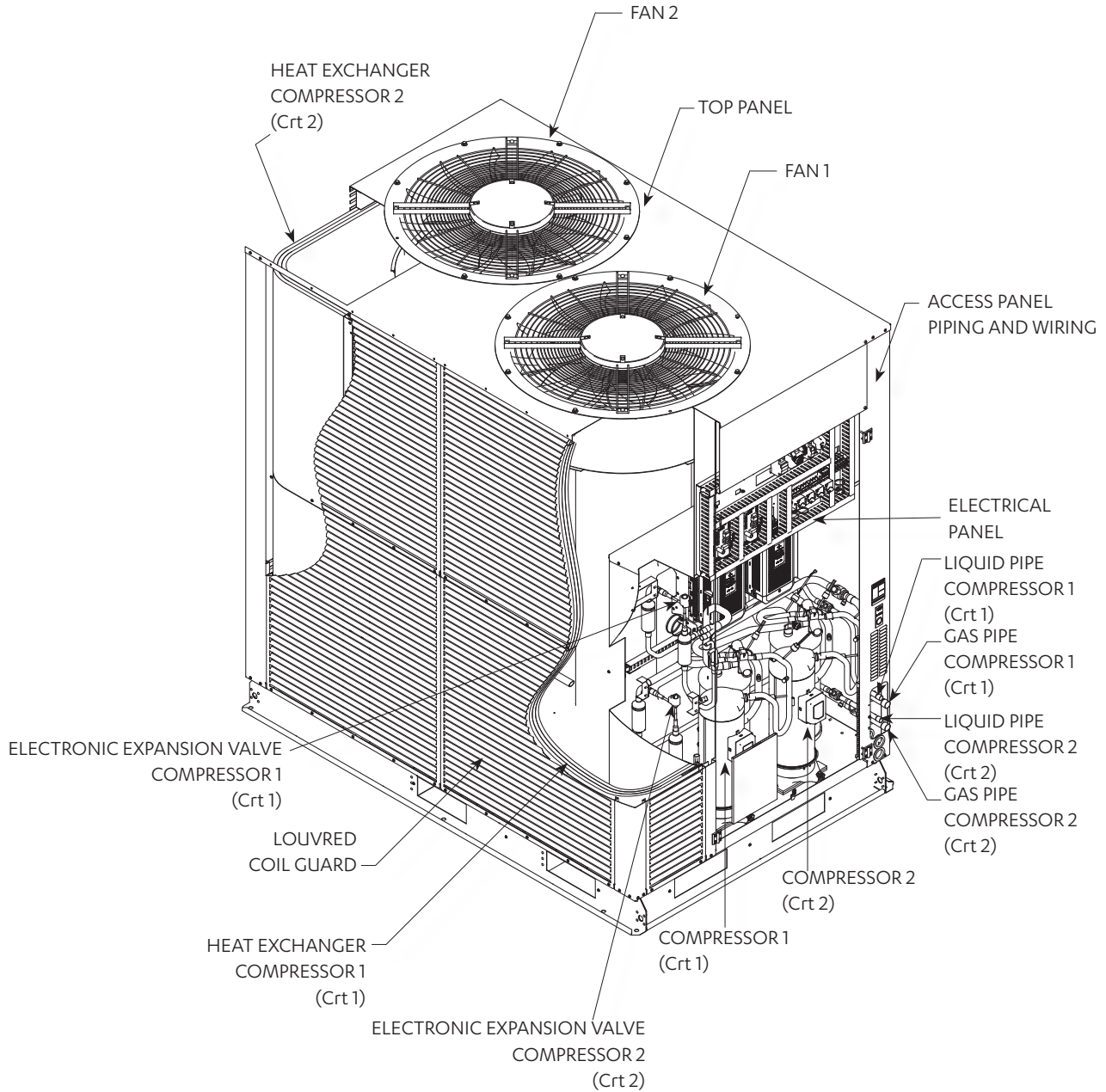

Electrical Control Panel

CRV720T

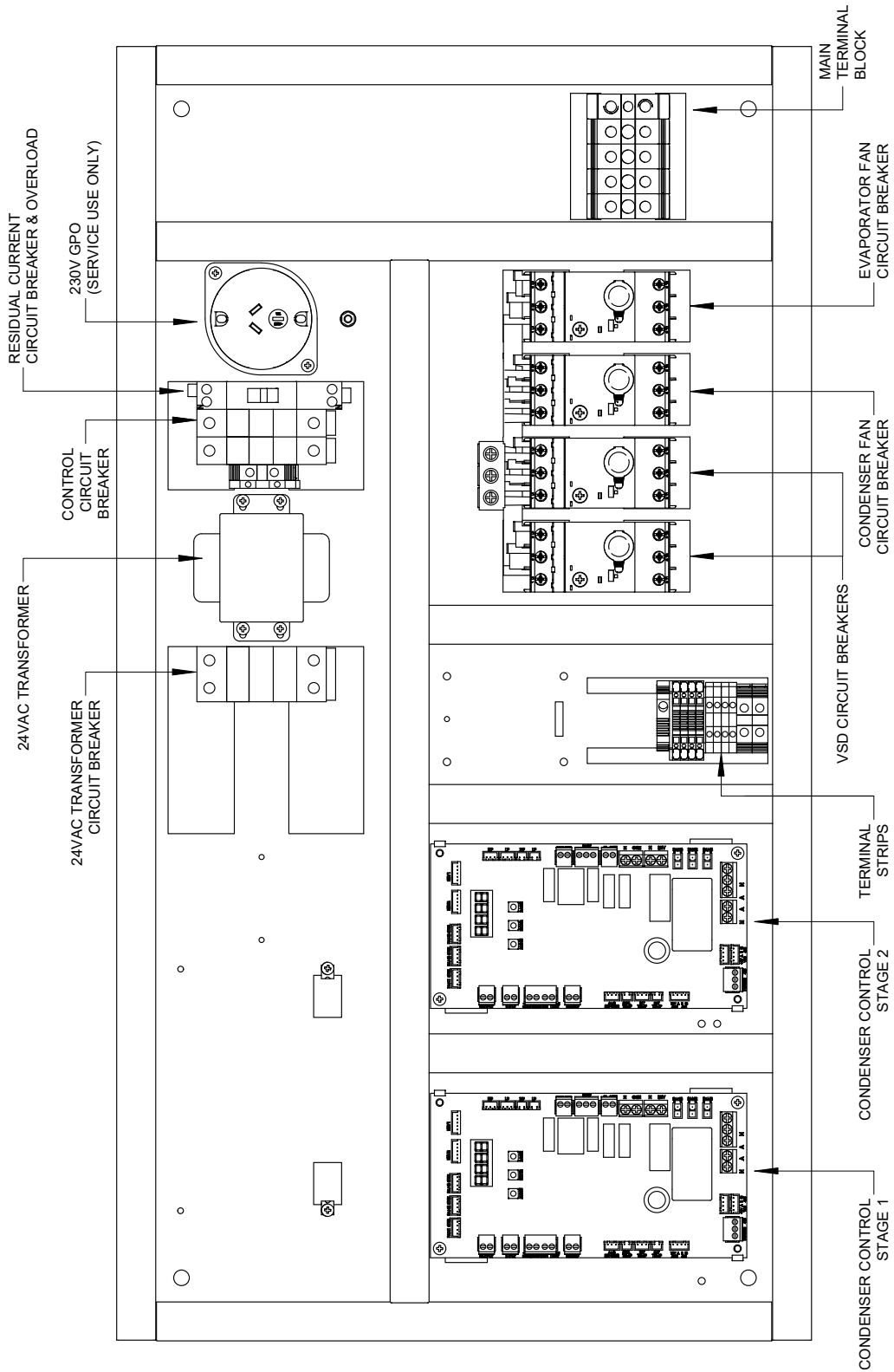

CRV850T / CRV960T

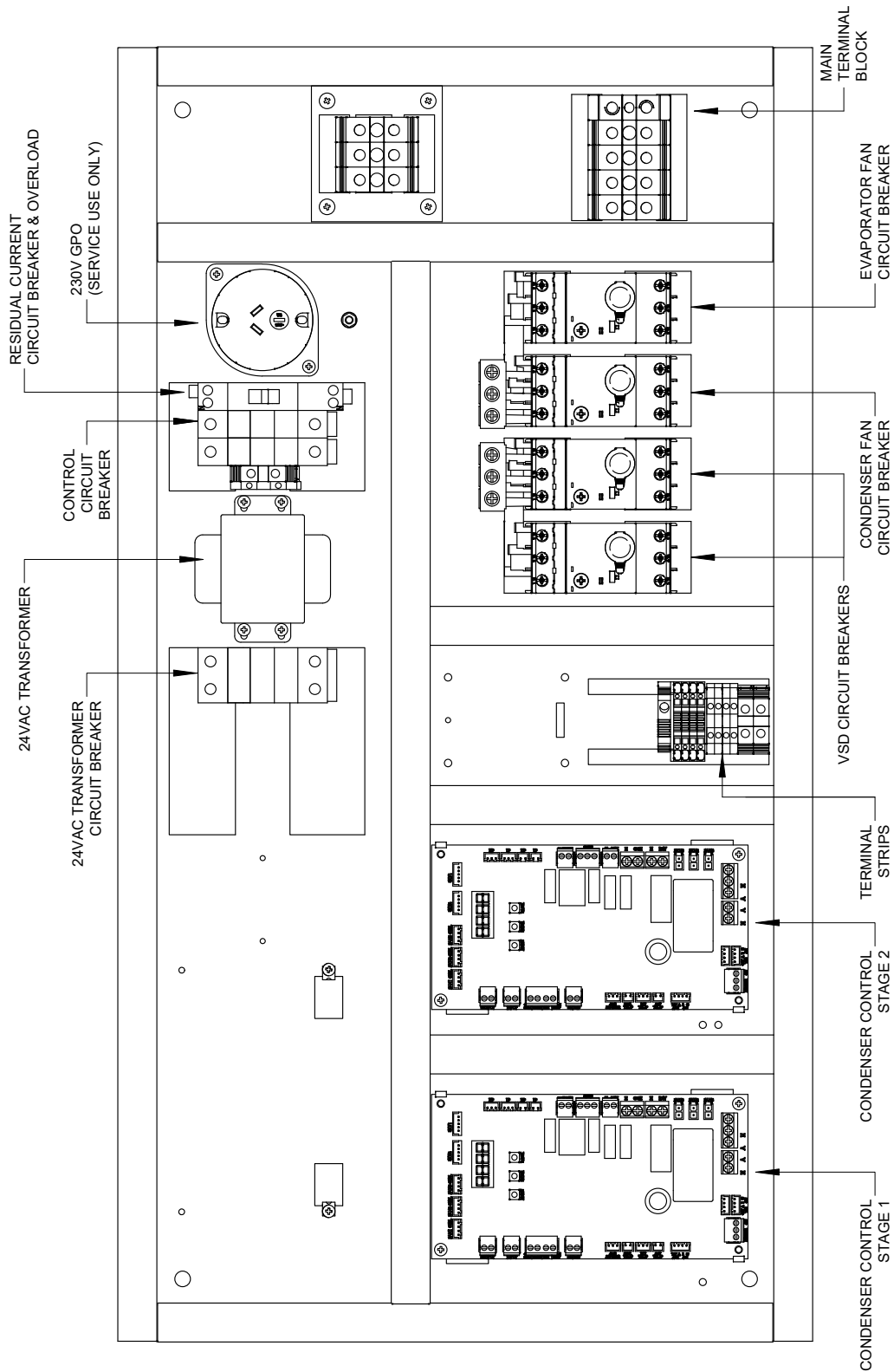

Group Control Option Electrical Board Layout

NOTE

Electrical board layout of 72kW shown below for illustration purposes only. Location for this option is same for the higher capacity.

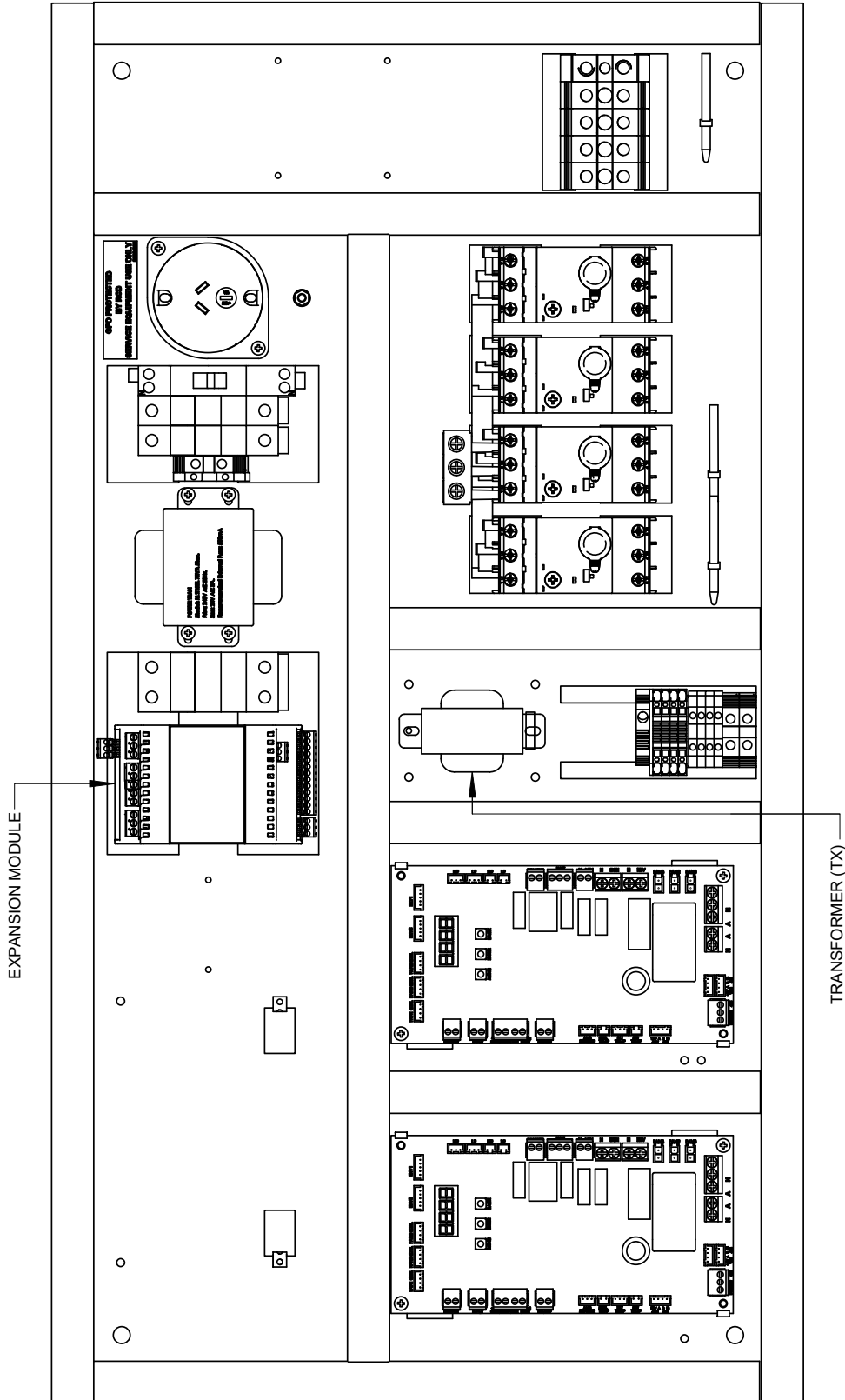

BMS Option Electrical Board Layout

NOTE

Electrical board layout of 72kW shown below for illustration purposes only. Location for this option is same for the higher capacity.

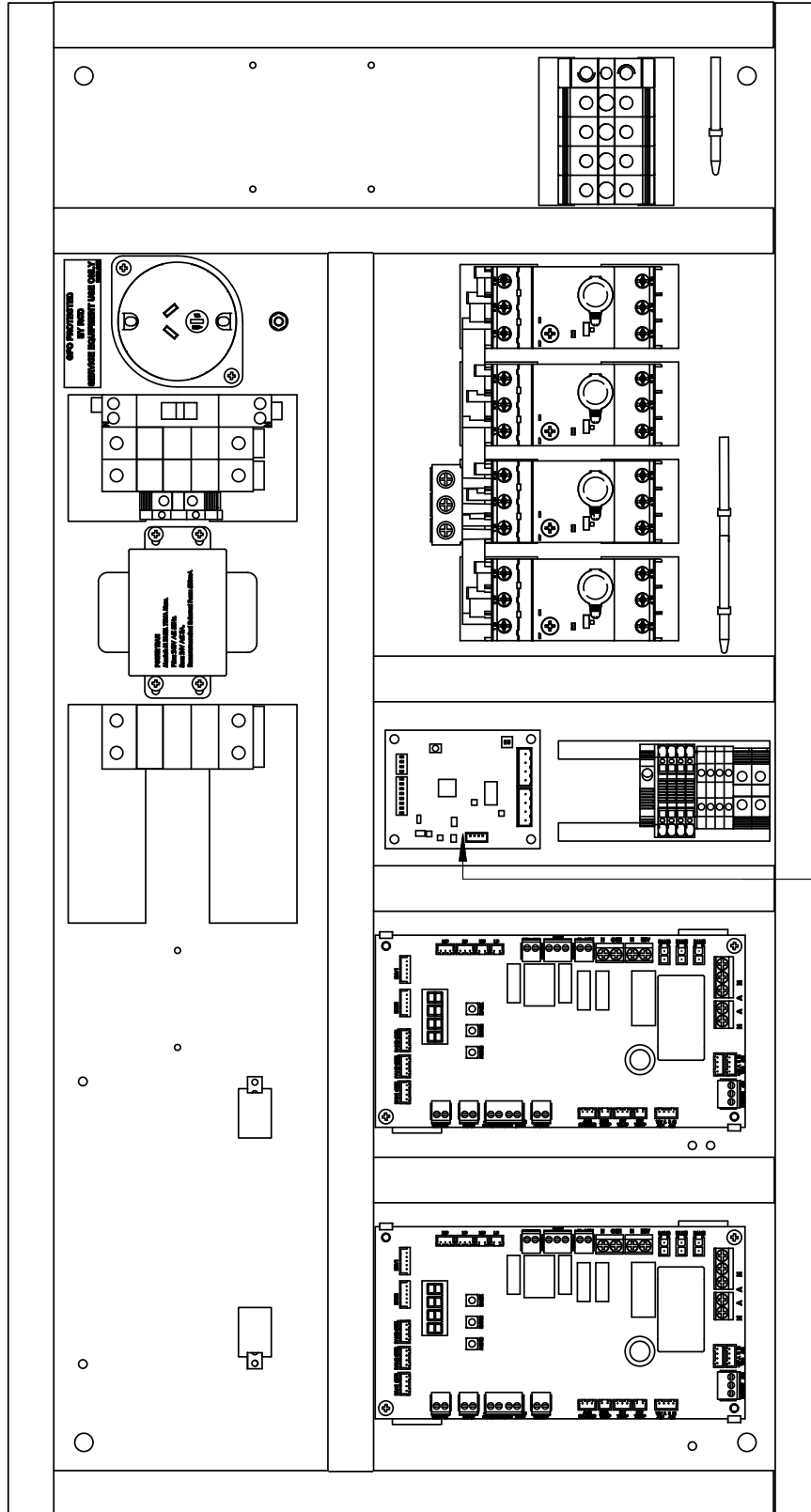

Unit Dimensions, Clearances and Weights

CRV720T

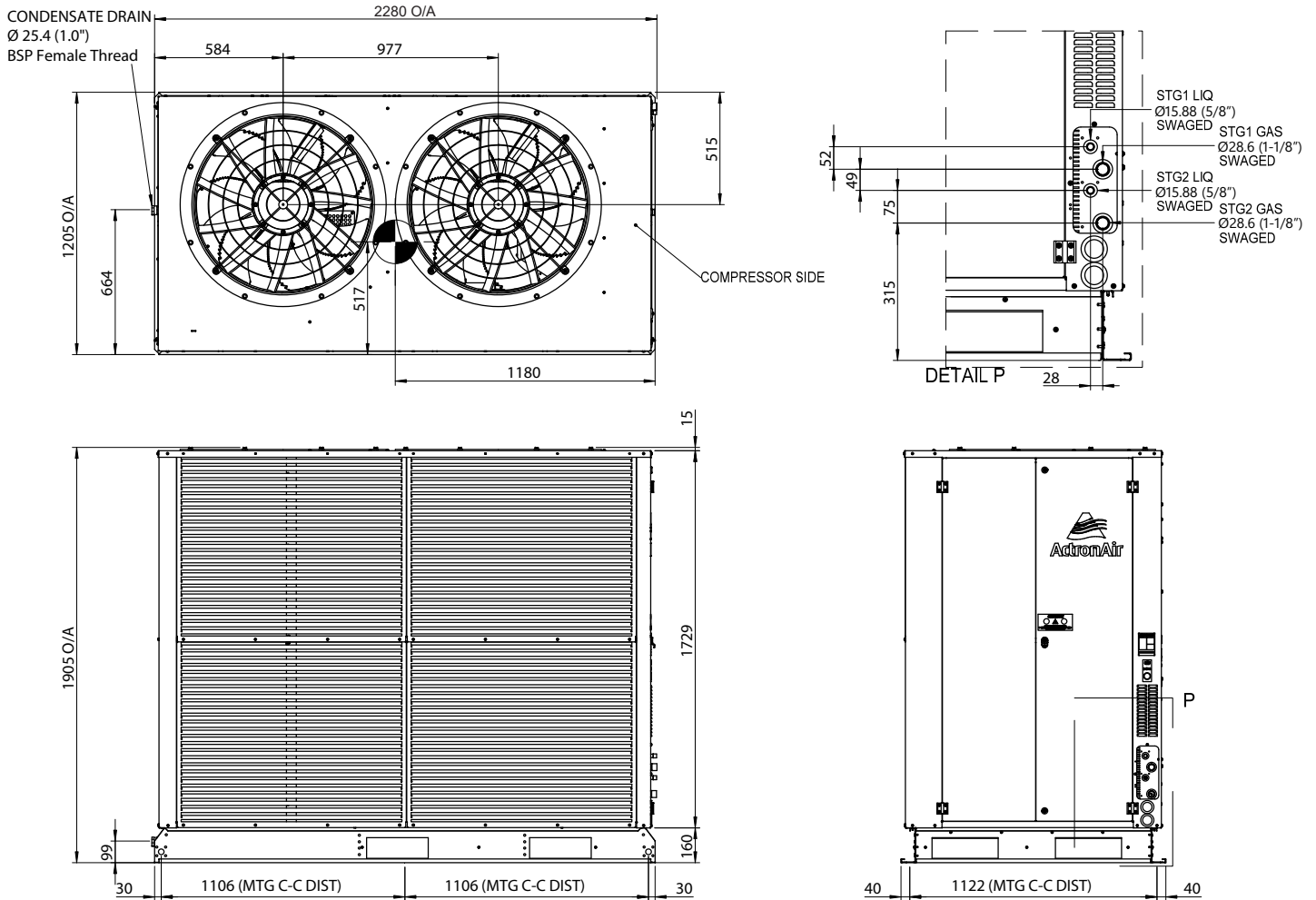

NOTES:

- Do not scale drawing. All dimensions are in mm unless otherwise specified. Refer to corresponding unit dimensional drawing for mounting hole details.
- The unit is designed to ensure all condensation is removed efficiently to avoid water pooling with the condenser. A single condensation drain point is provided. An external drip tray may be used, if unit requires to be extra water tight.
- Drawing is subject to change without notice.
- Use M12 Bolt for feet mounting
- Not to scale drawing. All dimensions are in mm unless otherwise specified.
- Refer to corresponding unit dimensional drawing for mounting hole details

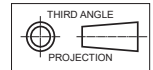

Unit Model Number	Overall Nominal Dimension (OA)			MTG C-C DIST Mounting Distance Base Foot (Centre to Centre)		Gas Pipe	Liquid Pipe
	H	W	D	F	E		
CRV720T	1905	2280	1205	1106	1122	Ø 28.60 mm (1-1/8") Swaged	Ø 15.88 mm (5/8") Swaged

CRV850T/ CRV960T

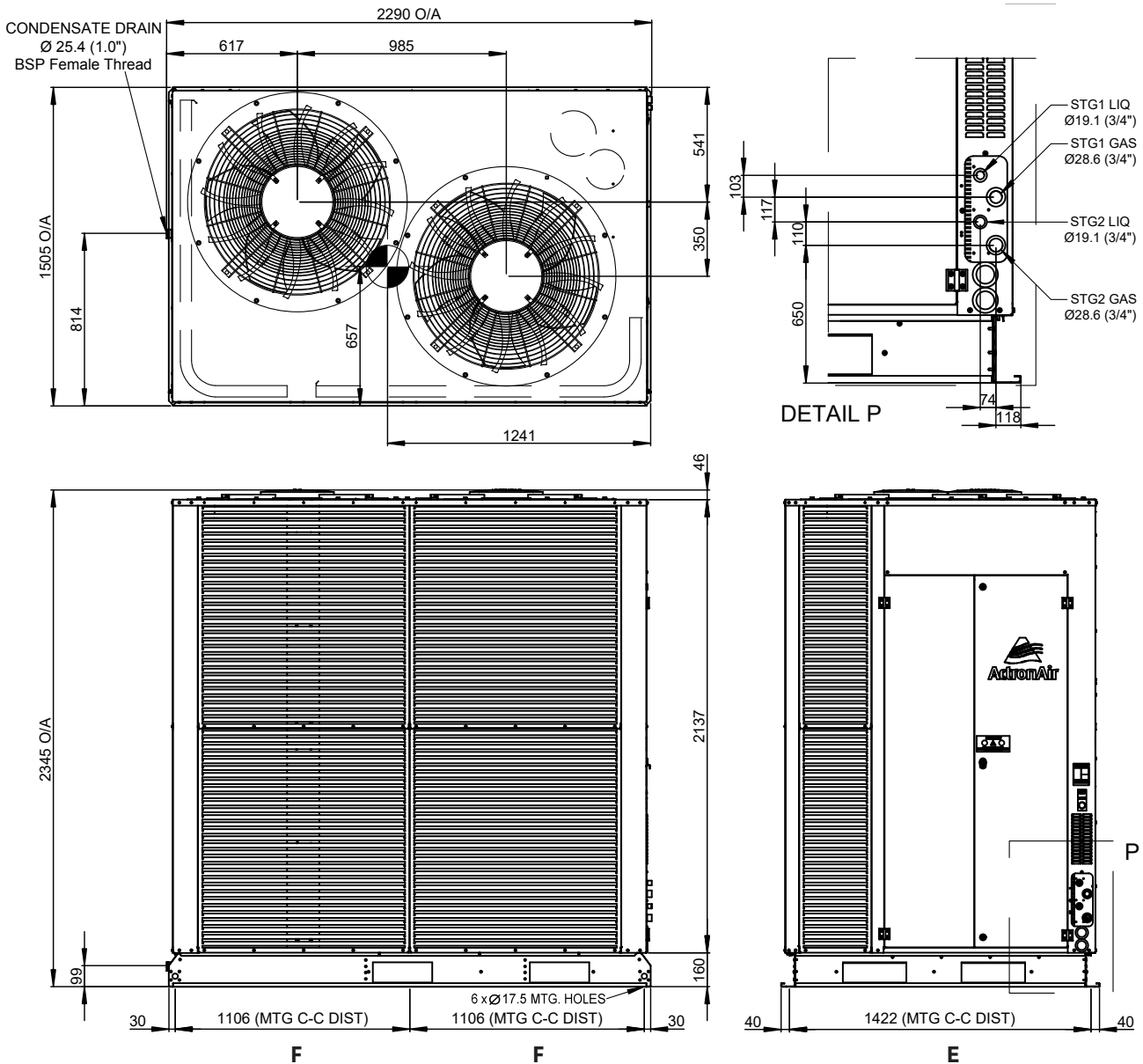

NOTES:

- Do not scale drawing. All dimensions are in mm unless otherwise specified. Refer to corresponding unit dimensional drawing for mounting hole details.
- The unit is designed to ensure all condensation is removed efficiently to avoid water pooling with the condenser. A single condensation drain point is provided. An external drip tray may be used, if unit requires to be extra water tight.
- Drawing is subject to change without notice.
- Use M12 Bolt for feet mounting
- Not to scale drawing. All dimensions are in mm unless otherwise specified.
- Refer to corresponding unit dimensional drawing for mounting hole details

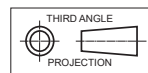

Unit Model Number	Overall Nominal Dimension (OA)			MTG C-C DIST Mounting Distance Base Foot (Centre to Centre)		Gas Pipe	Liquid Pipe
	H	W	D	F	E		
CRV850T	2345	2290	1505	1106	1422	Ø 28.60 mm (1-1/8") Swaged	Ø 19.05 mm (3/4") Swaged
CRV960T							

Service Clearances, Airflow Allowances and Weights

NOTES:

Drawing is subject to change without notice.
 Drawing for illustration purposes only (may vary depending on capacity)

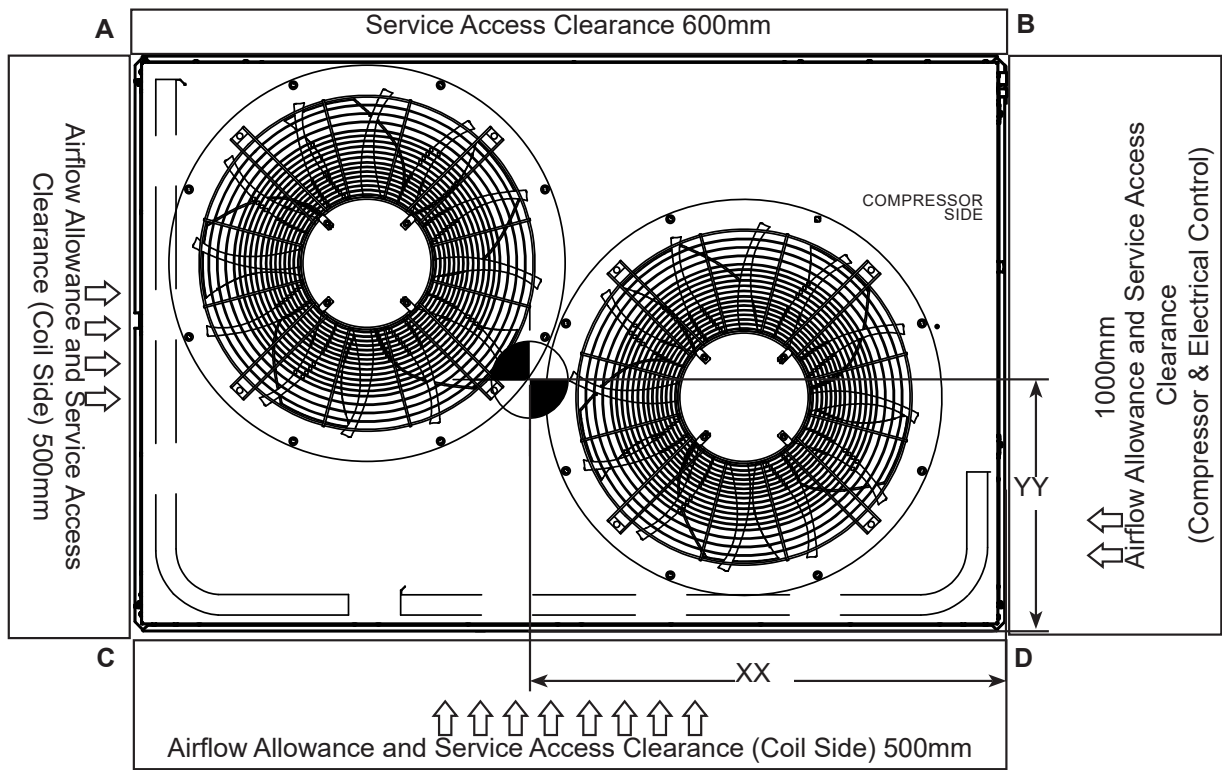

Unit Model Number	Total Weight (Kg)	Corner Weights (Kg)				Centre of Gravity Position	
		A	B	C	D	XX	YY
CRV720T	700	132	201	140	227	1235	502
CRV850T	834	129	285	195	225	1213	663
CRV960T	906	139	300	239	228	1213	663

NOTES:

1. Service Access Areas and Spaces for Airflow Clearances are suggested minimum based on the condition that the spaces around the units are free from any obstructions and a walkaway passage of 1000 mm between the units or between the unit and the outside perimeter is available.
2. Minimum service access areas and spaces for airflow clearances are responsibilities of the installer, ActronAir will not be held liable for any extra charges incurred due to lack of access and space for airflow.
3. Under all circumstances, condenser air must not recirculate back onto condenser coil. Keep all clearance free of any obstruction.
4. Refer Pipe Connection Details on Specifications Sheet.
5. Maximum External Static of Outdoor Fans is 90 Pa.
6. Installation of this unit should be in accordance with Electrical Safety Standard, AS/NZS 60335.2.40.

Unit Lifting Procedure

NOTE

All drawings are for illustration purposes only. Actual unit may vary depending on the model.

Crane Lifting Method

NOTE: Crane lifting is recommended over fork lift method.

EQUIPMENT REQUIRED FOR CRANE LIFTING:

- Spreader bar
- 4 x shackles
- 2 x nylon slings

NOTES:

- Refer to catalogue for unit weight before selecting shackles.

PROCEDURE:

1. Use 4 x Bow or Dee shackles to connect the lifting holes.
2. Slip nylon slings through all shackles.
3. Ensure slings are protected by rubber pads or similar if slings are draped across unit edges, corners, supply or return air spigots. This will prevent the unit from being damaged during lifting.
4. SPREADER BAR must be used when lifting the unit.
5. Remove all screws and washers that secure the unit to the timber pallet.
6. Remove pallet from the unit. (See pallet removal instructions below).

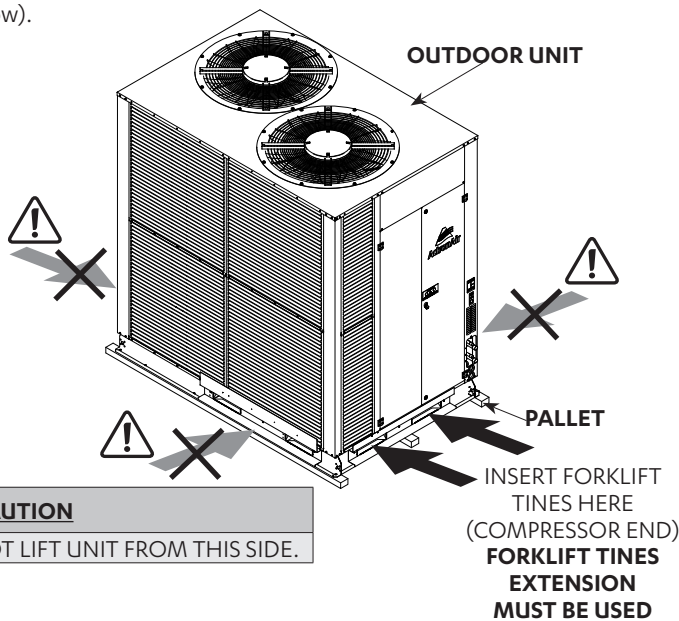

CAUTION

DO NOT LIFT UNIT FROM THIS SIDE.

PALLET REMOVAL INSTRUCTIONS

PROCEDURE:

1. Remove Plate-Unit Protector from pallet and unit assembly.
2. Remove Pallet from the unit as shown:

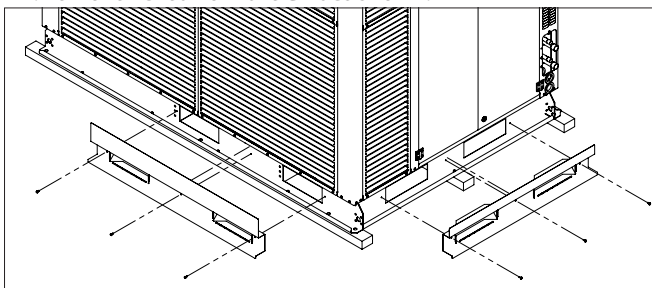

WH&S REGULATIONS MUST BE OBSERVED AND WILL TAKE PRECEDENT DURING LIFTING PROCESS.

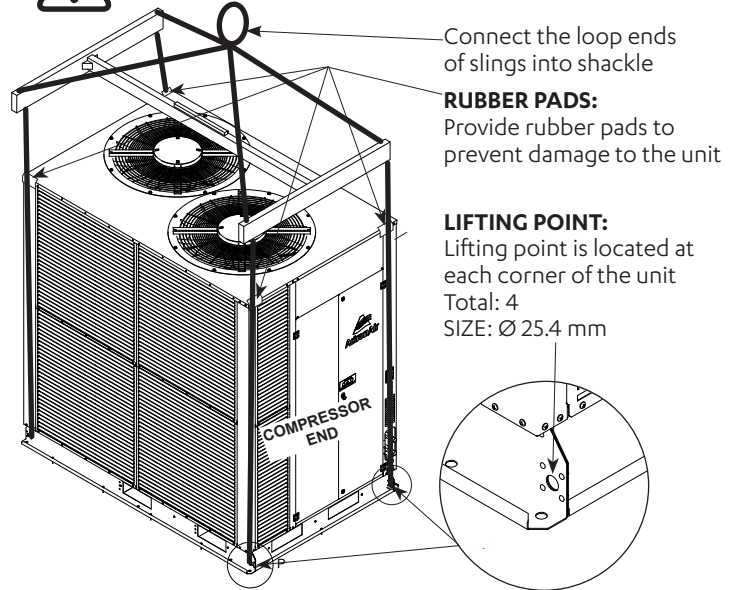

Fork Lift Method

NOTES:

1. Ensure to remove screws and washers only when it is required to disassemble unit from the pallet.
2. All dimensions are in mm.
3. Length of fork lift tines must pass the unit middle section, in order to safely carry the unit.

PROCEDURE:

1. To move the unit around with a forklift, insert the fork tines through the unit feet assembly, as shown.
2. Only fork the unit through compressor end. (see illustration for location of compressor end)

UNIT FORK LIFTING HOLE DIMENSIONS

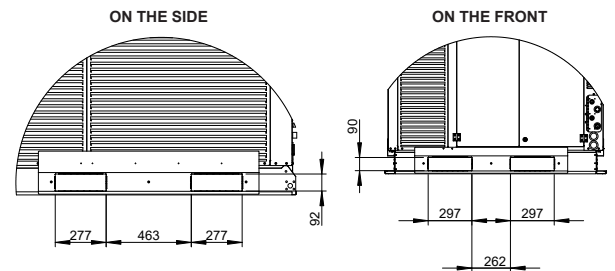

1. (Lift unit to remove pallet by lifting method A or B)

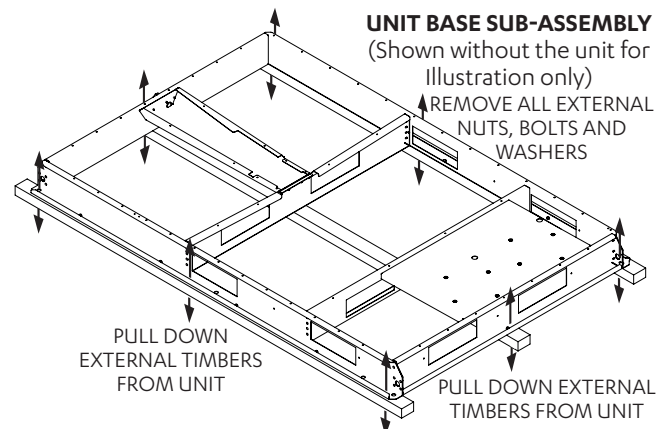

Banking of Outdoor Units

End-To-End Configuration

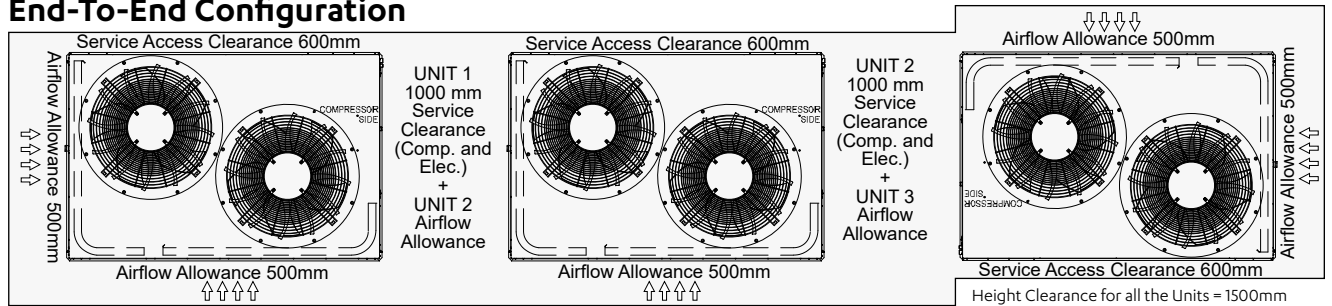

Cluster Configuration

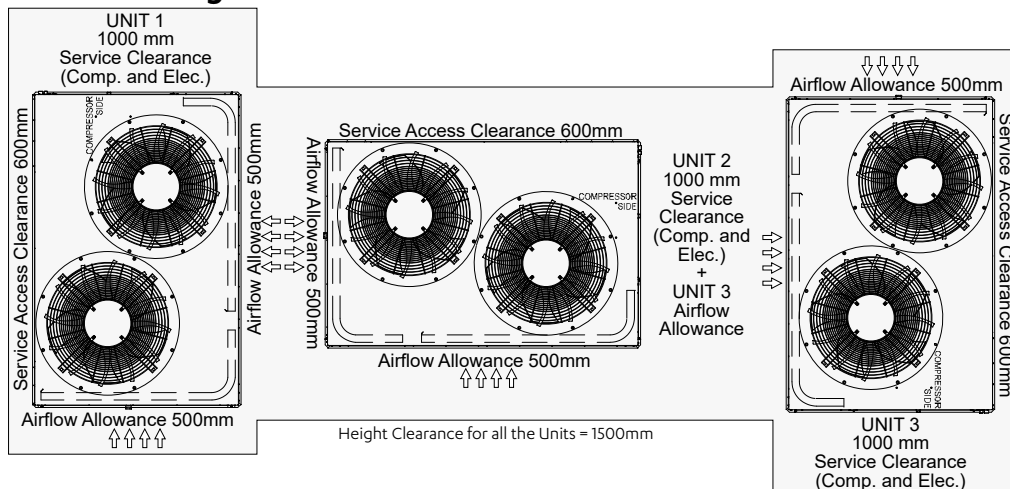

Side-By-Side Configuration

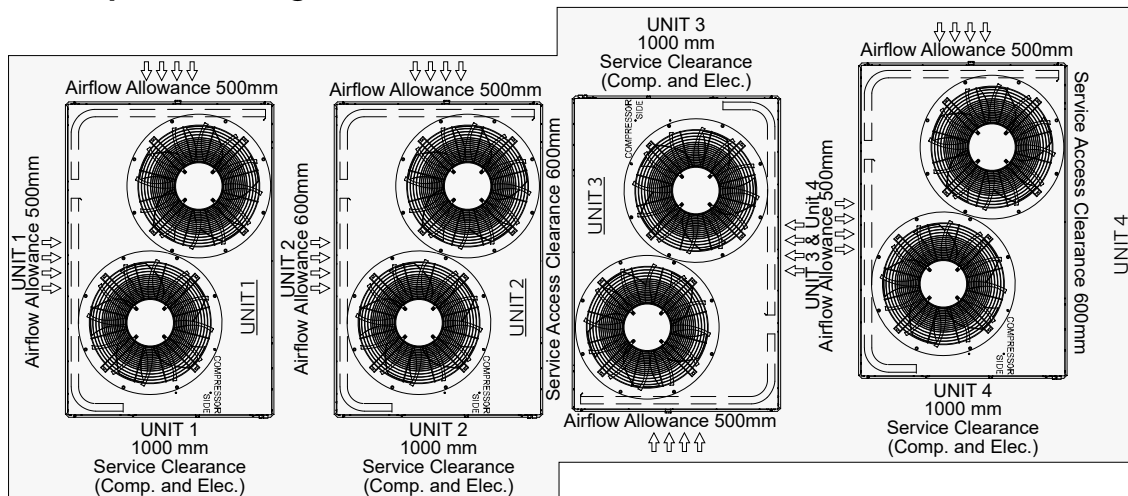

NOTES

- The suggested Clearance and Airflow Allowances (given above) are the minimum and based on the condition that the spaces around the units are free from any obstructions and walkway passage of 1000mm between the units or between the unit and the outside perimeter is available.
- Minimum service access areas and spaces for airflow are responsibilities of the installer, ActronAir will not be held responsible for any extra charges incurred due to lack of access and space for airflow.

Condensate Drainage Instructions

NOTES

- Do not use pipes or tube coming out from the unit to lift the unit.
- Support drain line for long pipe run.
- Parts for the Condensate Trap are not supplied with the unit.
- Refer to unit dimension page for specification of drain connectors.
- Test condensate drain installation to ensure that water flows freely and does not leak. Also check that the drain tray does not overflow.
- CRV850T/960T model shown. All drawings are for illustration purposes only. Actual unit may vary depending on the model.

Suggested Minimum Slope to Ensure Correct Drainage

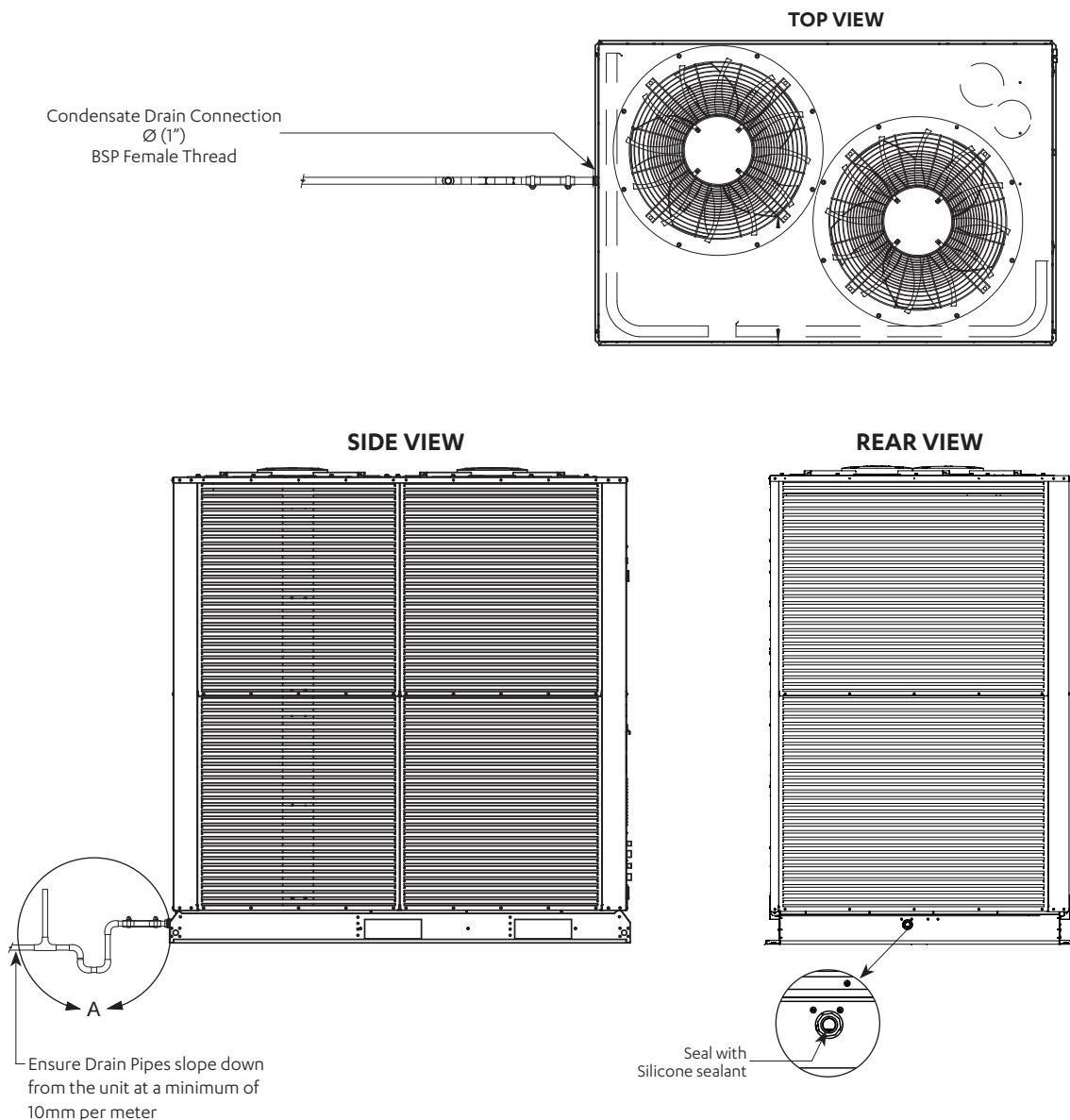

Suggested Drain Trap Details

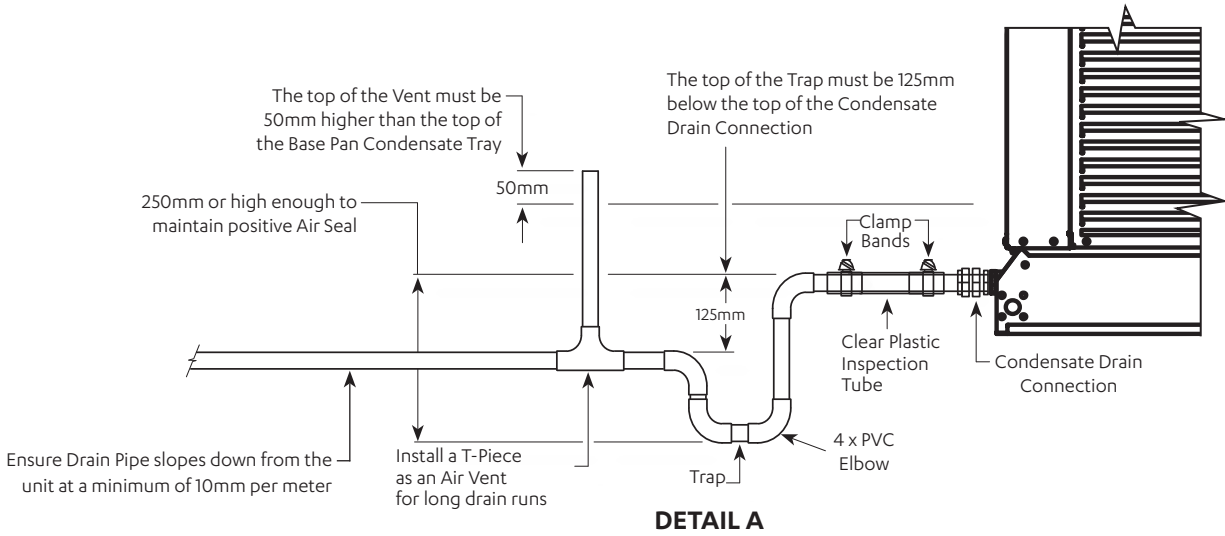

Outdoor Unit Preparation

NOTE

Drawing shown below is for illustration purposes only. Actual unit may vary depending on model.

1. Rotate the Hex Recess 90° using 8mm allen key.
2. Open the Access Doors-Electrical as illustrated below.

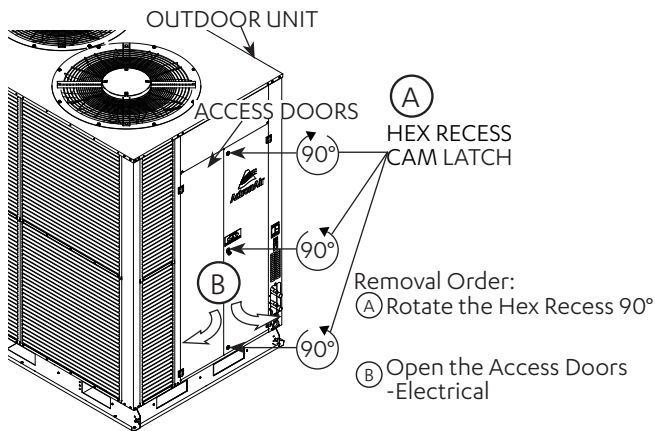

- b. Remove Shipping blocks as shown below.

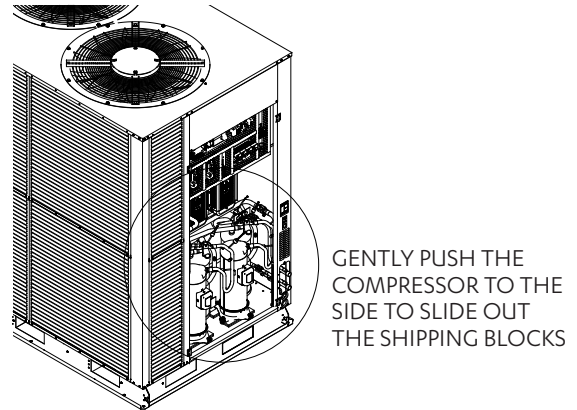

- c. Re tighten the 3 x compressor feet bolts (12 to 14Nm).

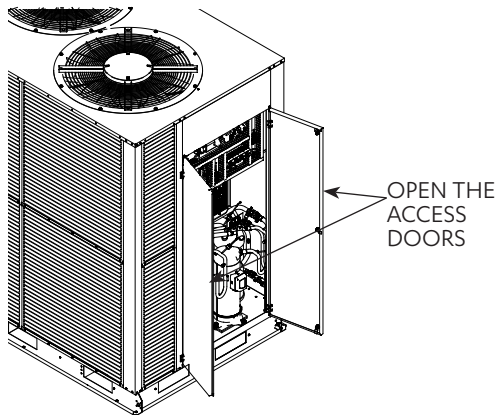
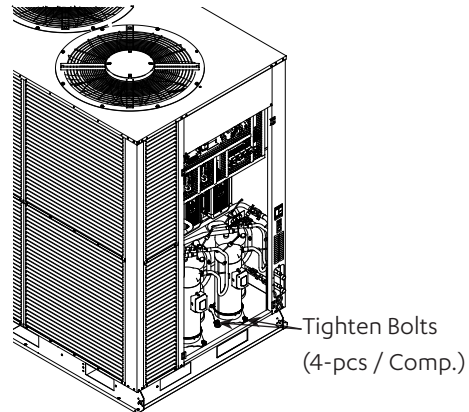

3. Remove the Shipping Blocks before installing Interconnection Field Pipes.

- a. Loosen the 4 x compressor feet bolts.

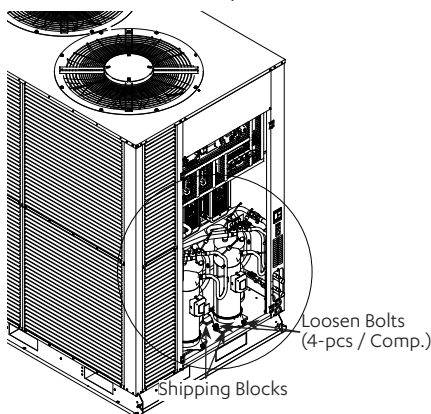

4. Install Interconnecting Field Pipes. Braze refrigeration piping.

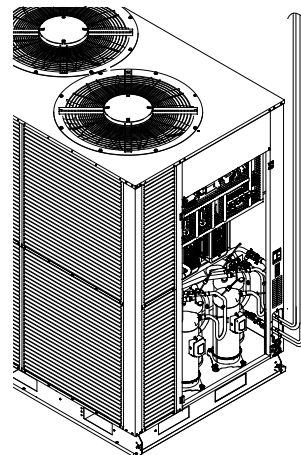

Warning: Live electrical within enclosure. Isolate electrical supply before removing panels. Authorised technicians access only.

Field Pipe Connection

Piping and Brazing



CAUTION

The outdoor unit described in this guide is designed to match only with an ActronAir indoor unit as specified in the Technical Selection Catalogue.

- The unit is supplied with factory charged refrigerant as stated in the Rating Label. The use of other material as a refrigerant may cause explosion and/or personal injury.
- Be aware of all the relevant regulations concerning the handling of refrigerant.
- The system of this unit operates with Polyester (POE)* oil.
- The maximum time any system can be opened to atmosphere is 15 minutes.
- It is important to work with absolute cleanliness.
- Secure Hot Work Permit as required.
- Brazing must be done with the use of Nitrogen to avoid carbon deposits into the pipes.
- The system must be evacuated thoroughly to 500 microns (see evacuation procedure).
- Never allow refrigerant to vent into the atmosphere. It is an offence to release refrigerant in Australia.
- Always reclaim refrigerant using equipment and container dedicated for the refrigerant used in the system.
- Only qualified technicians are allowed to perform any work described in this guide and all work must be carried out in accordance with Australia and New Zealand refrigerant handling code of practice.

Maximum allowable total equivalent field pipe length is 75 metres, see diagram on the next page. This includes all the equivalent pipe fitting losses and vertical height difference. Vertical height difference must not exceed 20 metres. Table below shows the equivalent straight pipe length of elbow fittings.

Pipe size Nominal Diameter	90° Long Radius Elbow	90° Short Radius Elbow	45° Long Radius Elbow	45° Short Radius Elbow
9.52 (3/8")	0.24	0.36	0.09	0.14
12.7 (1/2")	0.27	0.41	0.12	0.19
15.88 (5/8")	0.30	0.45	0.15	0.23
19.05 (3/4")	0.40	0.60	0.18	0.27
22.22 (7/8")	0.46	0.69	0.21	0.32
25.4 (1")	0.52	0.78	0.24	0.36
28.60 (1-1/8")	0.55	0.83	0.27	0.41
34.96 (1-3/8")	0.70	1.00	0.55	0.85

Interconnecting Pipe Run Recommendation

Unit Model no	CRV720T		CRV850T		CRV960T	
Max pipe length (Meters)	0-60	60-75	0-45	45-75	0-35	35-75
Max vertical length (Meters)	20 (Included in max. pipe length)					
Field pipe sizes IN.(mm)						
Liquid pipes	5/8" (15.88)	3/4" (19.05)	5/8" (15.88)	3/4" (19.05)	3/4" (19.05)	
Gas pipes	1-1/8" (28.60)		1-1/8" (28.60)	1-3/8" (34.96)	1-1/8" (28.60)	1-3/8" (34.96)

The chosen field pipe sizes must align with the suggested dimensions specified in the Tables for Refrigeration Piping found in the Refrigeration Section of the specifications. Should the installation necessitate the use of field pipe diameters that differ from the recommended sizes due to specific application conditions, it is advised to reach out to ActronAir for guidance.

Most of unit pipe connections are factory swagged to easily fit to the recommended field pipe diameter.

When it is required to install other refrigeration devices, such as refrigerant drier, solenoid valve and the like, include the equivalent straight pipe length of the device in the calculation of total equivalent field pipe length and mechanical connections shall be accessible for maintenance purposes.

Both pipes are required to be insulated.

Improper insulation can result in condensation forming on the pipework's surface, potentially leading to dripping condensation.

NOTE

All drawings are for illustration purposes only. Actual unit may vary depending on the model.

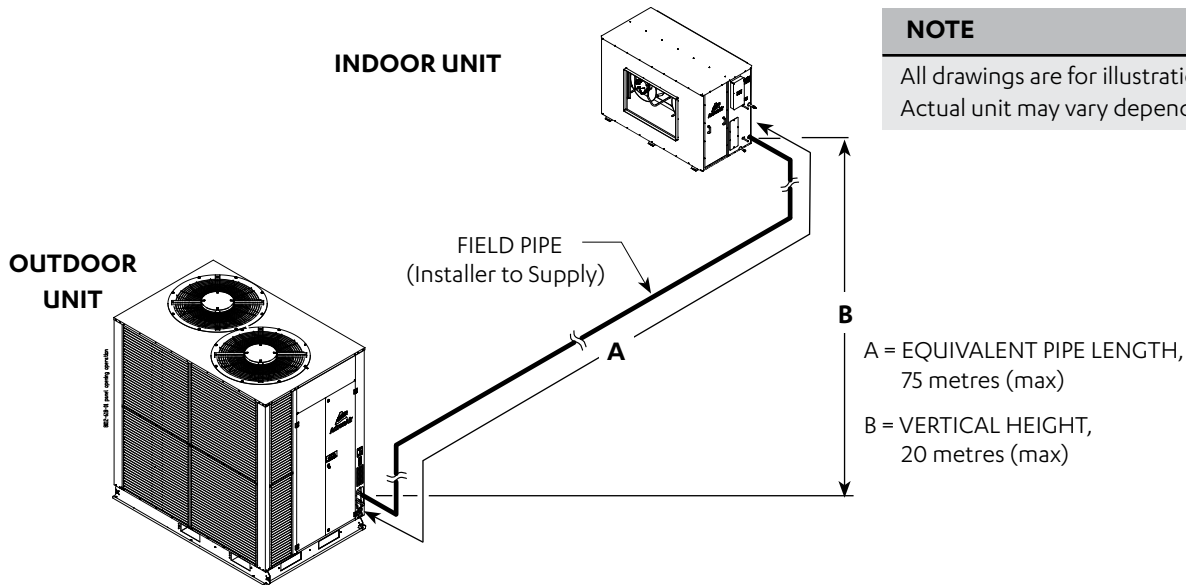

Example of Total Equivalent Field Pipe Length Calculations

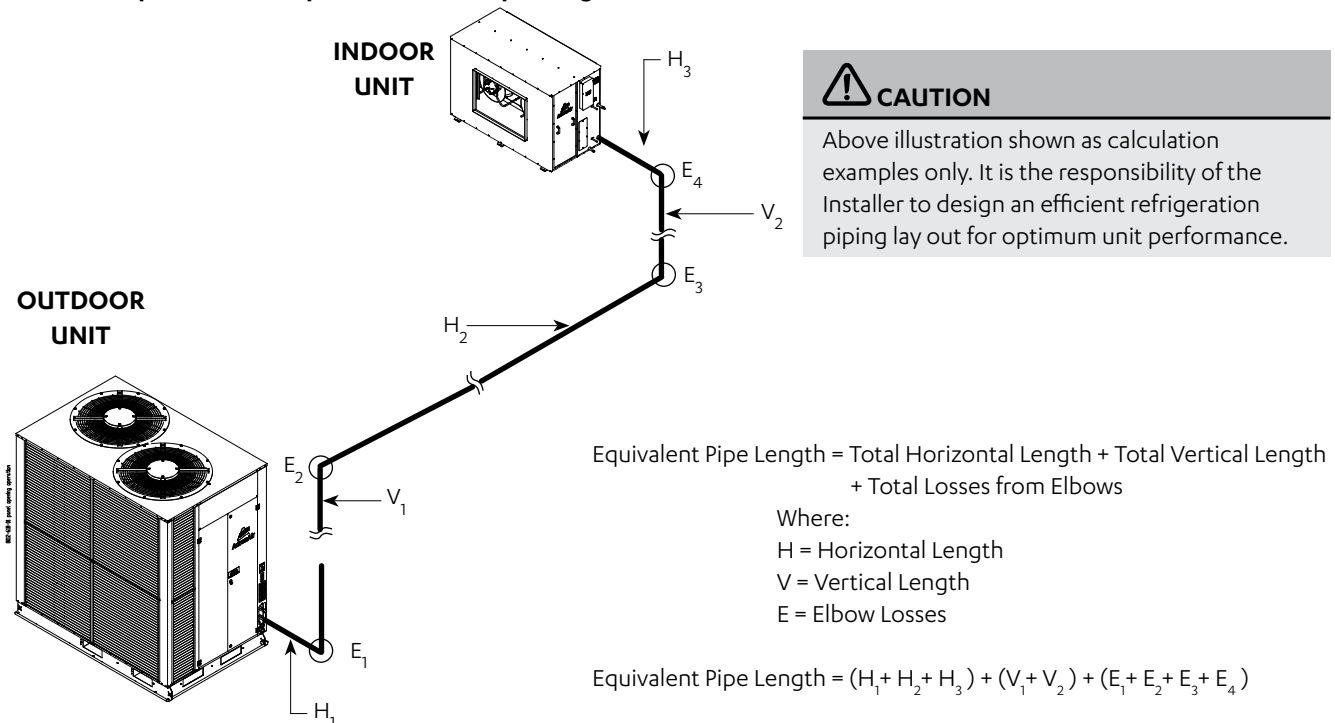

CAUTION

Brazed joints should only be made while purging Nitrogen through the system. Failure to do so will cause carbon deposit to be left on the internal pipe surface, that in turn can cause system failure and void warranty.

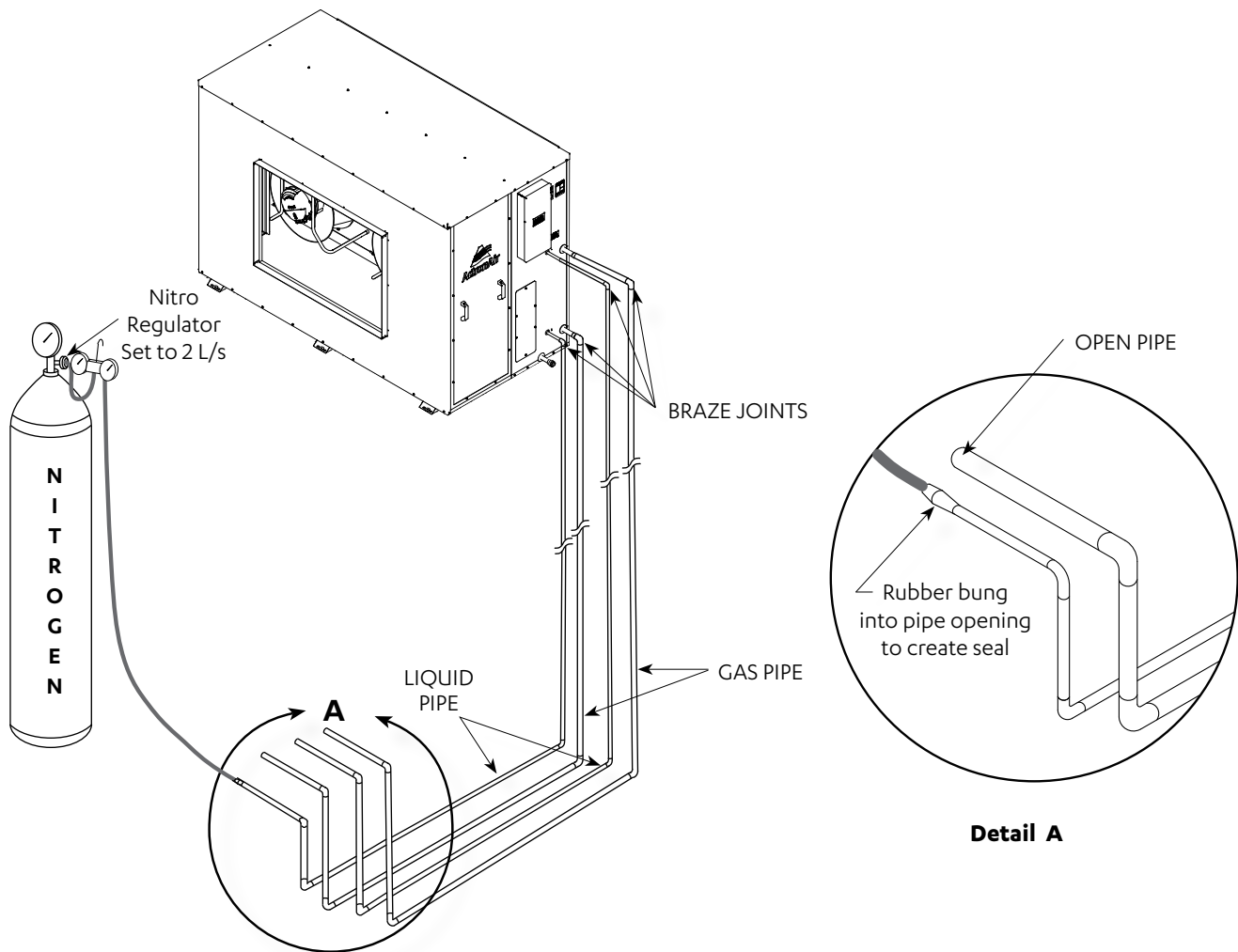

Installing interconnecting pipe work to indoor, nitrogen bleed procedure (First fit or rough in stage only)

1. Run interconnecting pipe work from condenser location to evaporator.
2. Release pressure in evaporator and remove caps.
3. Fit copper tube into tail, set nitro bottle and regulator up at condenser end of pipe work.
4. Fit nitrogen line into liquid line with rubber bung to seal the connection. The seal will prevent air being sucked into pipe work.
5. Leave suction line open, set nitro regulator for nitrogen to flow through pipe work at 2 l/s flow rate @20kPa.
6. Braze required joints as quick as possible. **See Diagram Above.**

Installing interconnecting pipe work to outdoor, nitrogen bleed procedure (First fit or rough in stage only)

1. Starting with circuit 1 system, remove piping caps from the condenser and fit pipe work into tails.
2. Fit nitro hose onto suction ball valve and fit open hose onto liquid line post valve.
3. Set nitrogen regulator to 2 l/s flow rate through pipe work and evaporator.
4. Braze remaining joints as quick as possible.
5. Allow the brazed joints to cool and conduct leak test in the connections.

Pressure Testing

Pressure test the system between 2500kPa and the system's maximum kPa as determined in **AS/NZS 5149.2:2016, Clause 5.2.2.1 Maximum Allowable Pressure**. Ensure pressure is held for no less than 1 hour

NOTES

Importance of Evacuation:

- Any non-condensable product left in the system can cause the pressure in the high side of the system to increase and in turn, the compression temperature to rise.
- Moisture will result in adverse reaction in the refrigerant circuit.
- To prevent chemical reactions in the system, any moisture must be removed at all costs.
- Oxygen (air) reacts with the compressor oil and can lead to faults such as compressor failure.

See Diagram Below:

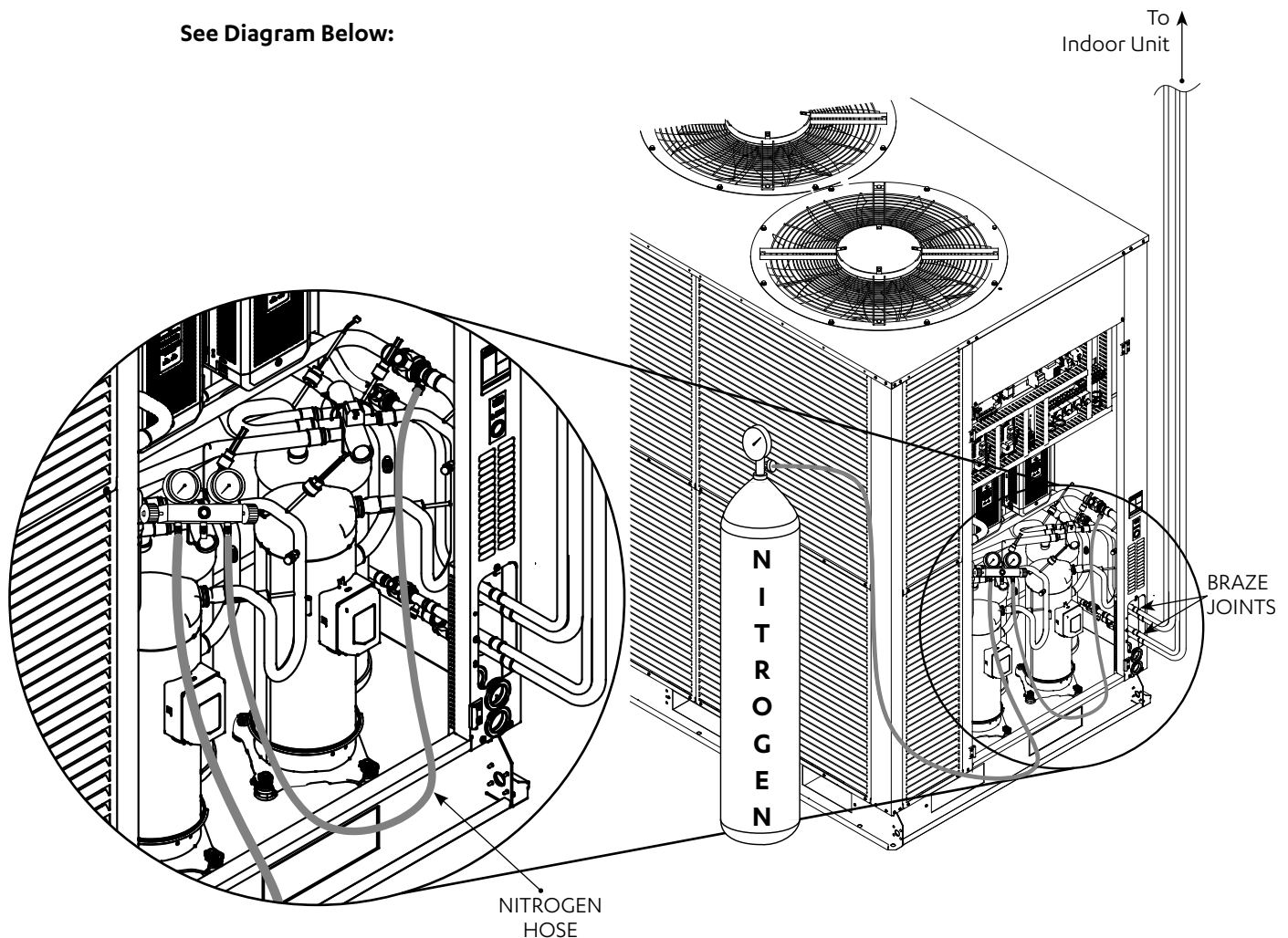

Evacuation Procedure (Triple Evacuation)

1. Fit service gauges to the ball valves (liquid line service valve and suction line service valve).
2. Evacuate the system to 1000 microns.
3. Check vacuum with vacu stat. Break the vacuum with dry Nitrogen to 100kPa.
4. Release Nitrogen pressure. Evacuate to 500 microns.
5. Check vacuum with vacu stat. Break the vacuum with dry Nitrogen to 100kPa.
6. Release Nitrogen pressure. Evacuate to 500 microns.
7. Check vacuum with vacu stat. Let the unit stand for 1 hour and with the vacuum not rising above 500 microns.
8. Open valve.

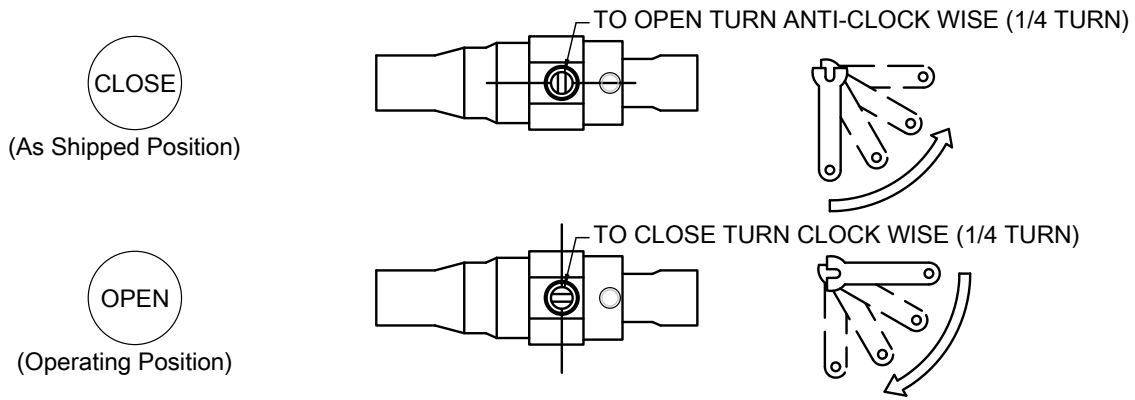

Specifications for Refrigeration

TABLE : REFRIGERATION PIPING							
Reverse Cycle (Outdoor / Indoor)		CRV720T / EVA720T		CRV850T/EVA850T		CRV960T/EVA960T	
Equivalent Pipe Length Range	metres	0-60	60-75	0-45	45-75	0-35	35-75
Max. Vertical Height Differential ⁽¹⁾	metres	20		20		20	
Field Pipe Size							
Liquid Line	inch (mm)	Ø 15.88 mm (5/8")	Ø 19.05 mm (3/4")	Ø 15.88 mm (5/8")	Ø 19.05 mm (3/4")	Ø 19.05 mm (3/4")	
Gas Line	inch (mm)	Ø 28.60 mm (1-1/8")		Ø 28.60 mm (1-1/8")	Ø 34.96 mm (1-3/8")	Ø 28.60 mm (1-1/8")	Ø 34.96 mm (1-3/8")
Outdoor Pipe Size							
Liquid Line	inch (mm)	Ø 15.88 mm (5/8") Swaged		Ø 19.05 mm (3/4") Swaged		Ø 19.05 mm (3/4") Swaged	
Gas Line	inch (mm)	Ø 28.60 mm (1-1/8") Swaged		Ø 28.60 mm (1-1/8") Swaged ⁽²⁾		Ø 28.60 mm (1-1/8") Swaged ⁽²⁾	
Indoor Pipe Size							
Liquid Line	inch (mm)	Ø 15.88 mm (5/8") Swaged		Ø 15.88 mm (5/8") Not Swaged			
Gas Line	inch (mm)	Ø 28.60 mm (1-1/8") Swaged		Ø 28.60 mm (1-1/8") Swaged ⁽²⁾			

NOTES

- ⁽¹⁾ Included in maximum field pipe length.
⁽²⁾ Cut swaged end on the unit to for field pipe, if required.

Refrigerant Charge Details (R-410A)													
Model		CRV720T				CRV850T				CRV960T			
Circuit No.		Circuit-1		Circuit-2		Circuit-1		Circuit-2		Circuit-1		Circuit-2	
Refrigerant Type		R-410A				R-410A				R-410A			
Factory Charge	gms	13370		13370		13330		13830		17120		18600	
Pre- charged Length	m	5				5				5			
Field Pipe Length Range	m	0-60	60-75	0-60	60-75	0-45	45-75	0-45	45-75	0-35	35-75	0-35	35-75
Additional Refrigerant per meter	gm/m	165	220	165	220	165	220	165	220	220			
Pre- charged Oil Quantity Length	m	40				55				75			
Additional Oil per meter	ml/m	25				25				NA			
Field Pipe Sizing in mm (inch)	LIQ.	Ø 15.88 (5/8")	Ø 19.05 (3/4")	Ø 15.88 (5/8")	Ø 19.05 (3/4")	Ø 15.88 (5/8")	Ø 19.05 (3/4")	Ø 15.88 (5/8")	Ø 19.05 (3/4")	Ø 19.05 (3/4")			
	GAS	Ø 28.60 (1-1/8")	Ø 34.96 (1-3/8")	Ø 28.60 (1-1/8")	Ø 34.96 (1-3/8")	Ø 28.60 (1-1/8")	Ø 34.96 (1-3/8")	Ø 28.60 (1-1/8")	Ø 34.96 (1-3/8")	Ø 28.60 (1-1/8")	Ø 34.96 (1-3/8")	Ø 28.60 (1-1/8")	Ø 34.96 (1-3/8")

Electrical Installation

All electrical work must be carried out by a qualified technician. Make sure all wiring is in accordance with local wiring rules. Wiring connections should be made in accordance with the wiring diagram provided.



DANGER

Live Electrical Supply !

- During installation of your air conditioning unit, it may be necessary to work in close proximity to live electricity. Only qualified technicians are allowed to perform these tasks.
- Follow all electrical safety precautions when exposed to live electrical components.
- Always make sure that all power supply, including remote controls, are disconnected before performing maintenance. Observe proper LOCK-OUT / TAG-OUT (LOTO) procedures to ensure that power cannot be inadvertently energised. Failure to disconnect power before maintenance procedure can result in serious injury or death.
- All electrical wiring must be in accordance with the relevant electrical authority rules and regulations.



CAUTION

STATIC SENSITIVE ELECTRONIC DEVICES !

- DO NOT handle electronic devices unless you are wearing an Anti-Static Wrist Strap that is connected to a EARTH. Failure to protect the electronic devices from static electricity may cause unrepairable damage.
- Static damaged electronic devices are NOT COVERED for replacement under warranty.

Wiring Diagram

The wiring diagrams specific for your air conditioning system are located on the inside of the electrical access panel.

Always refer all wiring installation, servicing and troubleshooting of this equipment to this diagram to ensure correct electrical connections are satisfied.

Supply and Power Requirements Procedure

It is the installer's responsibility to provide power supply wiring to the sub-mains isolator. Wiring should conform to the current electrical authority regulations and all wiring connections to be as per electrical diagram provided with the unit.

- Confirm that the power supply available is compatible with the unit nameplate ratings. The supply power must be within +6% to -6% of the rated voltage as per AS60335.1.
- Protect electrical service from over current and short circuit conditions in accordance with the latest edition of the AS/NZS 3000 "Australian / New Zealand Wiring Rules". Protection devices are to be sized accordingly as per to the electrical specifications of the unit.
- Complete the outdoor unit power supply wiring into the sub-mains isolator.
- Secure the power cords and control cables that enters in/exits out the unit. Use the cable ties provided in the electrical panels.
- Provide proper unit earthing in accordance with local and national wiring rules.
- Installer to connect an appropriate load break (AC3) isolator in sub mains wiring.

Compressor Voltage Balance Requirement

Check the voltage at the mains supply terminals to determine if it is balanced. Voltage imbalance on three phase systems can cause motor overheating and premature failure. The maximum allowable imbalance is + 2.0% should voltage imbalance exceed this value, check unit wiring connections to locate and rectify faults or contact local supply authority.

Crankcase Heater

Crankcase Heater is to be disconnected for pipe lengths 8m or less.

Electrical Connection

NOTES

- To minimise noise interference, Data and Power cable clearance should be maintained as much as possible.
- All drawings are for illustration purposes only. Actual unit may vary depending on the model.
- All electrical components do not come with the unit, must be purchased separately.

DETAILED WIRING DIAGRAM IS PROVIDED WITH THE UNIT.

Outdoor Unit: Located at the back of electrical/compressor access panel.
 Indoor Unit: Located at the back of electrical box cover.

- ① **MAINS WIRING (400VAC)**
 (Three Phase + Neutral + Earth) 50Hz
- ② **INTER-CONNECTING POWER CABLE (230/400VAC)**
 2a (Single Phase + Neutral + Earth) 50Hz
 2b (Three Phase + Neutral + Earth) 50Hz
- ③ **DATA CABLE TO WALL CONTROLLER**
 (Cat5E UTP (AWG 24) Data Cable)
- ④ **EXTRA LOW VOLTAGE DATA CONTROL WIRING**
 (2 Core Shielded Twisted Pair 7/0.30 (0.5mm²) Data Cable)

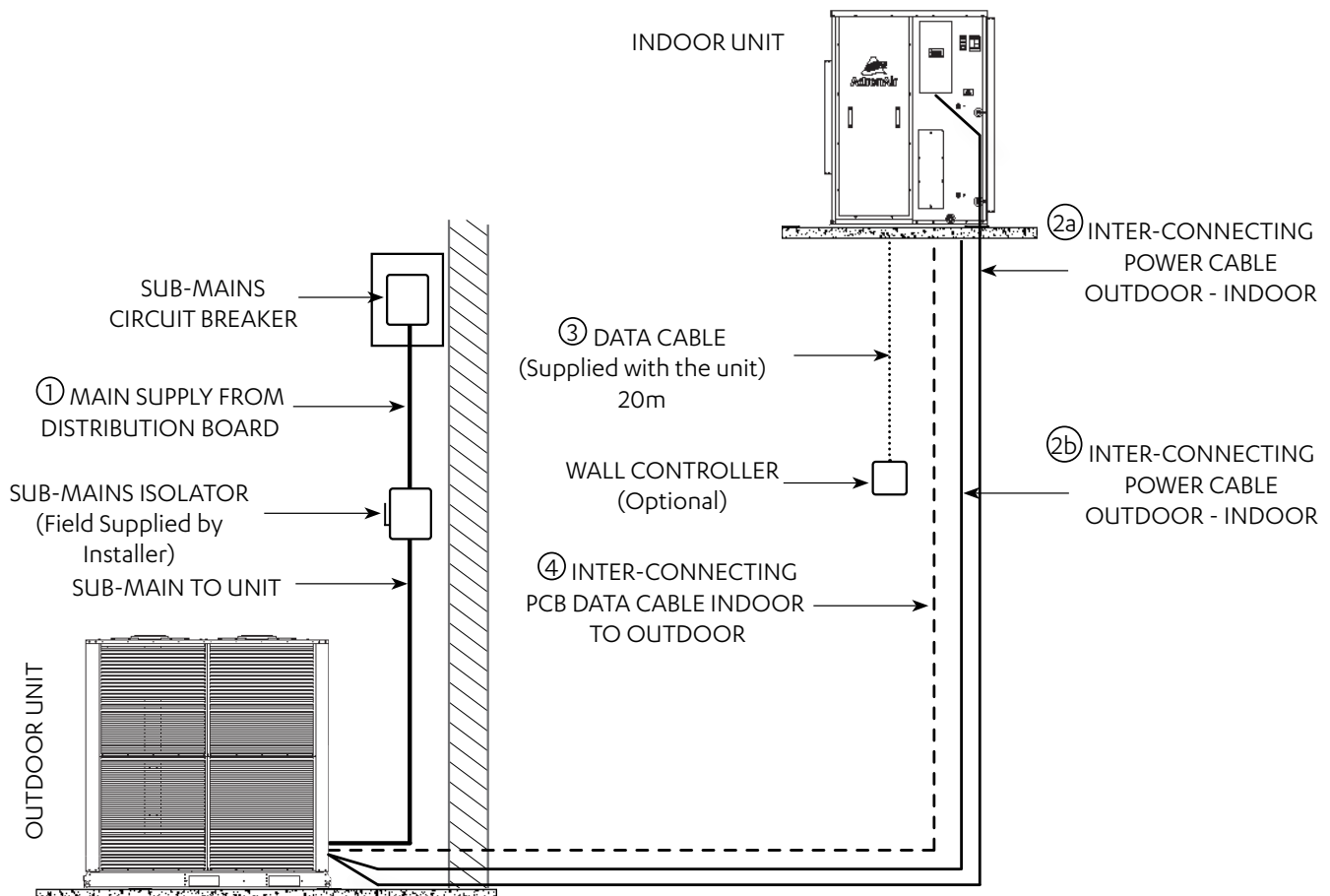

Data Cable Shielding Instructions

2 Core Twisted (ActronAir Part Number: AEDC2)

NOTES

- Maintain the twist of the core wires up to the Green Terminal Plug.
- Maximum strip length of outer insulation to the Green Terminal Plug is 50mm.
- Make sure the cable colors used for the Data Terminal in Outdoor Unit match the Data Terminal in Indoor unit.

Outdoor Unit Data Terminal (Green Plug)

“Terminal A” - White Wire

“Terminal B” - Black Wire

“Terminal G” - Shield Wire

Indoor Unit Data Terminal (Green Plug)

“Terminal A (+)” - White Wire

“Terminal B (-)” - Black Wire

“Terminal G” - Shield Wire

Insert data cable through the lower snap bushing and first cable tie on the right hand side of the electrical panel.

Connect core wires and shield wire into the Outdoor Board green terminal plug marked “INDOOR A, B and G”.

(Refer to unit wiring diagram for complete wiring connection details).

NOTE

All drawings are for illustration purposes only. Actual unit may vary depending on the model.

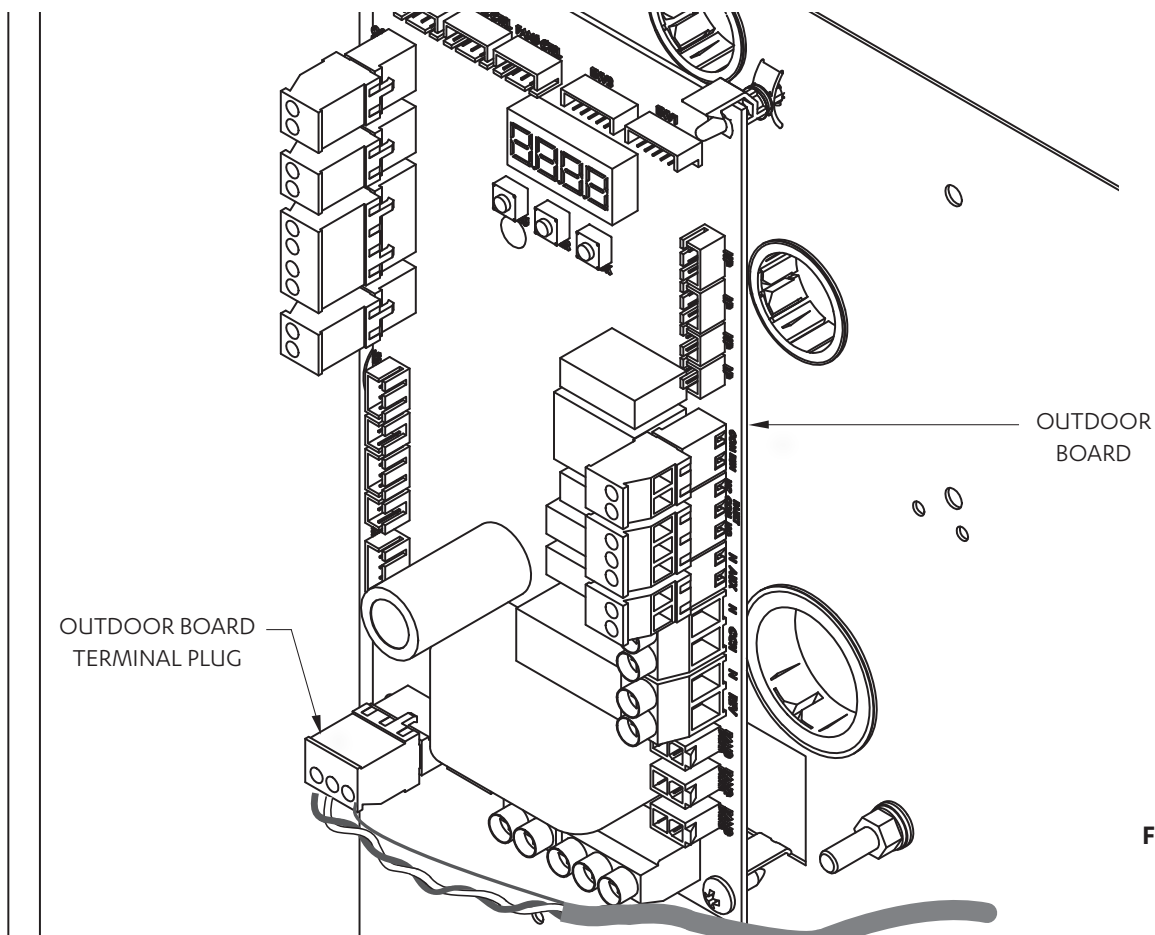

Fig. 3

Circuit Breaker Size Recommendation

Model	Circuit Breaker Size
	Amps
CRV720T / EVA720T	63
CRV850T / EVA850T	80
CRV960T / EVA960T	80
PKV720T	63
PKV850T	80
PKV960T	80

Notes:

Refer to latest edition of AS/NZS 3000 or AS/NZS 3008 Australian/New Zealand Wiring Rules to determine required cable size.

Wall Controller Options

Wall Controller Options

A maximum of three (3) wall controllers in the below combinations is allowed per unit. See below table.

Options	Wall Controllers		
	C1	C2	C3
1st Option	NEO		
2nd Option	NEO	NEO	
3rd Option	NEO	NEO	LR7-1 / LC7-2
4th Option	NEO	LR7-1 / LC7-2	
5th Option	NEO	LR7-1 / LC7-2	LR7-1 / LC7-2
6th Option	LR7-1 / LC7-2		
7th Option	LR7-1 / LC7-2	LR7-1 / LC7-2	
8th Option	LR7-1 / LC7-2	LR7-1 / LC7-2	LR7-1 / LC7-2

NOTES

- NEO - Available in White (NTW-1000) and Black (NTB-1000).
- LC7-2, LR7-1 and LM-RS-2 - Available in White and Grey.
- In the instance of a combination of NEO and LR7-1 / LC7-2 being connected together, the NEO will always need to be addressed as C1.
- Refer to catalogue for available controller for this product.

Wiring Configuration : Recommended

NOTES

- Diagram shown below is a general representation only. Refer to individual unit wiring diagram for complete wiring connection details.
- Long runs beside Mains cables or TV antenna cables should be avoided.
- Wiring configuration for LR7-1 and LC7-2 wall controller is the same.
- Daisy connection is not allowed for the NEO wall controller.
- Two Ferrite Clips*, if supplied, are to be placed 200mm and 400mm from the NEO controller respectively.

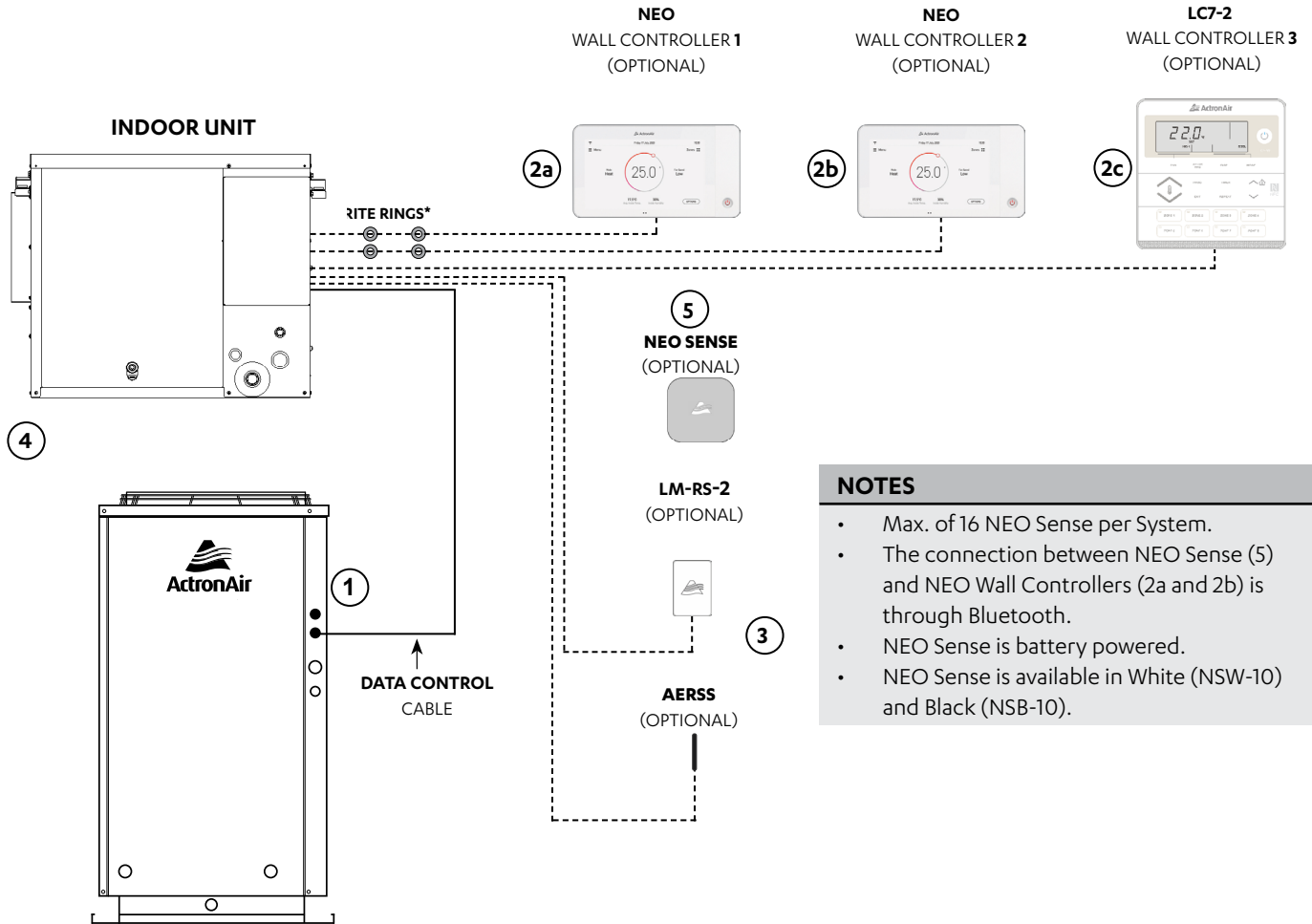

Split System

Item	Description	Maximum Cable Length
1 to 4	Outdoor PCB to Indoor PCB	100 m
4 to 2a, 4 to 2b	Indoor PCB to Wall Controller	90 m
4 to 2c	Indoor PCB to Wall Controller 3	100 m
4 to 3	Indoor PCB to Remote Sensor	100 m
4 to 5	Indoor PCB to ZC and ZS	100 m

Description	Cable Type
Indoor to Wall Controller	Cat5e UTP (AWG 24) Data Cable
Indoor to Remote Sensor	Cat5e UTP (AWG 24) Data Cable
Indoor to Outdoor Data Cable	2 Core (1 Pair) Twisted Pair, 7/0.30 (0.5mm ²) Shielded Data Cable

Wiring Configuration : Alternate

NOTES

- Diagram shown above is a general representation only. Refer to individual unit wiring diagram for complete wiring connection details.
- Long runs beside Mains cables or TV antenna cables should be avoided where possible.
- Wiring configuration for LR7-1 and LC7-2 wall controller is the same.

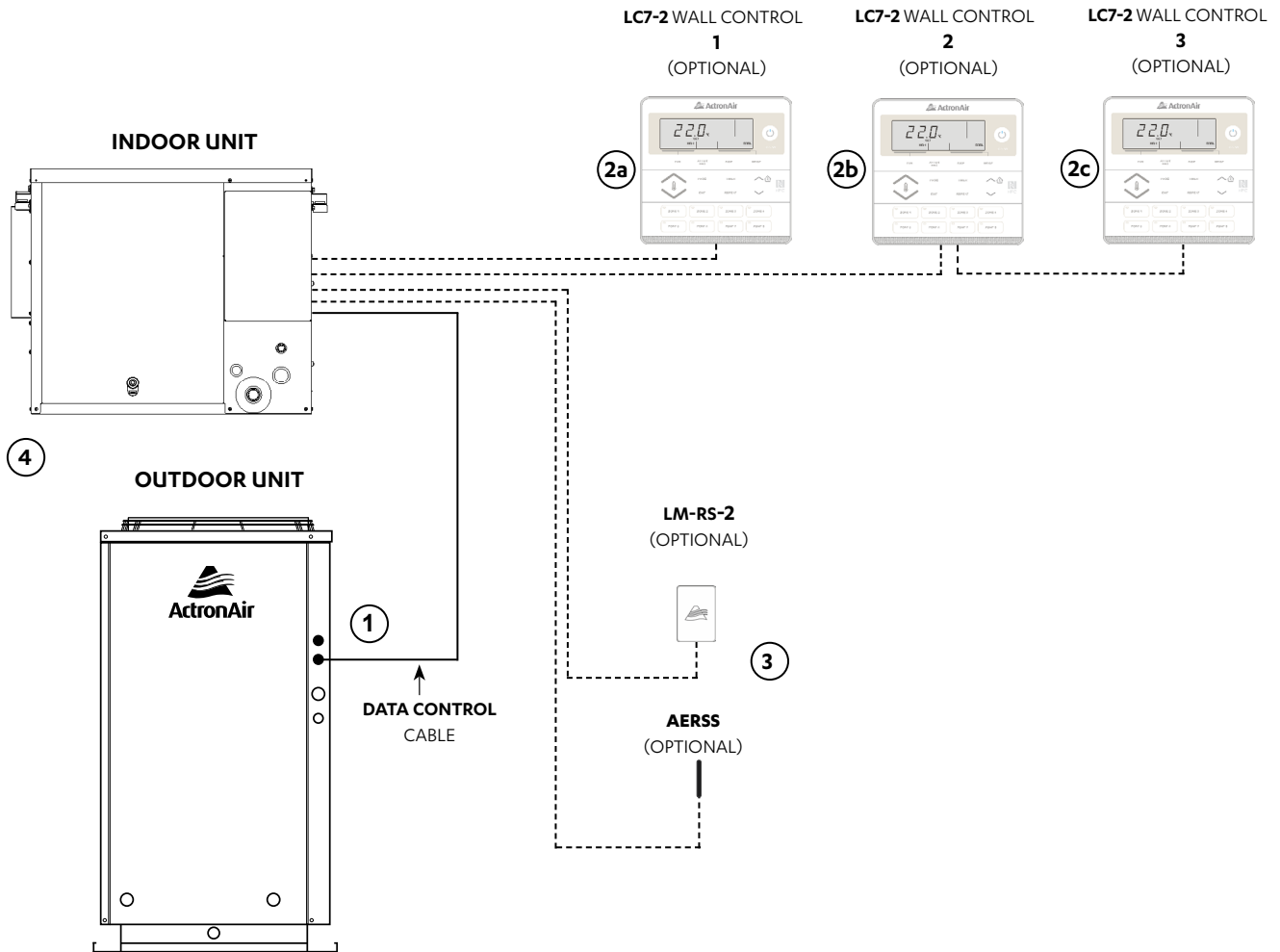

Split System

Item	Description	Maximum Cable Length
1 to 4	Outdoor PCB to Indoor PCB	100 m
4 to 2a	Indoor PCB to Wall Controller 1	100 m
4 to 2c	Indoor PCB to Wall Controller 3 (last controller)	75m total (Daisy Chain)**
4 to 3	Indoor PCB to Remote Sensor	100 m

** Maximum Daisy Chain connection is up to 2 wall Controls.

Description	Cable Type
LR7-1 Field Control Wiring	Cat5e UTP (AWG 24) Data Cable
Indoor to Remote Sensor	Cat5e UTP (AWG 24) Data Cable
Indoor to Outdoor Data Cable	2 Core (1 Pair) Twisted Pair, 7/0.30 (0.5mm ²) Shielded Data Cable

Wiring Connections

LR7-1 and LC7-2 Wall Control Wiring Connections

WALL CONTROL WIRING

- POWER: - BROWN / ORANGE
- 485 A: - BLUE
- 485 B: - BLUE-WHITE
- GND: - BROWN-WHITE / ORANGE-WHITE
- NOT USED: - GREEN / GREEN-WHITE

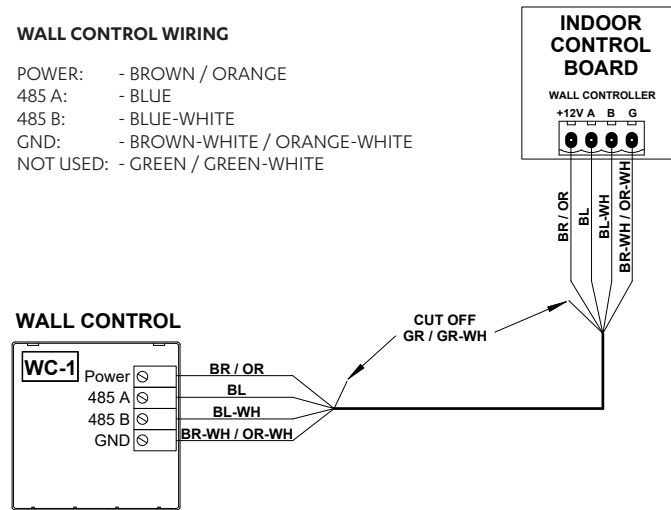

NEO Wall Control Wiring Connections

NOTES

Two FERRITE CLIPS, if supplied, should be installed 200 mm away and FERRITE 2 should be 400 mm away from the Wall Control.

NEO Hard Wiring

WALL CONTROL WIRING

- POWER: - BROWN / ORANGE
- 485 A: - BLUE
- 485 B: - BLUE-WHITE
- GND: - BROWN-WHITE / ORANGE-WHITE
- NOT USED: - GREEN / GREEN-WHITE

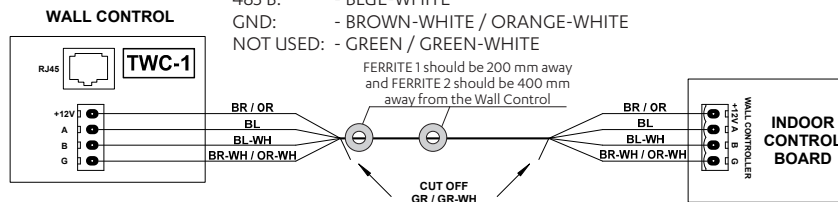

NEO RJ45 Wiring

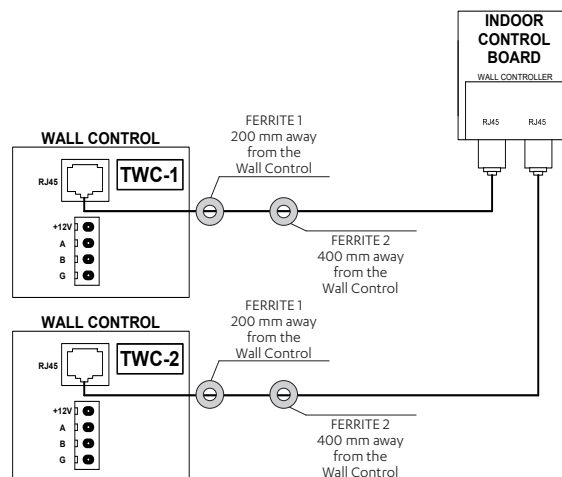

LM-RS-2 Optional Sensor Wiring Connections

REMOTE SENSOR WIRING

- PAIR 1: - BLUE / BLUE-WHITE
- PAIR 2: - ORANGE / ORANGE-WHITE
- PAIR 3: - GREEN / GREEN-WHITE
- PAIR 4: - BROWN / BROWN-WHITE

NOTE:

- PAIR 1 AND 2 USED FOR ILLUSTRATION PURPOSES ONLY.
- CUT OFF AND TERMINATE ANY UNUSED PAIRS TO ENSURE NO WIRING IS LEFT EXPOSED.

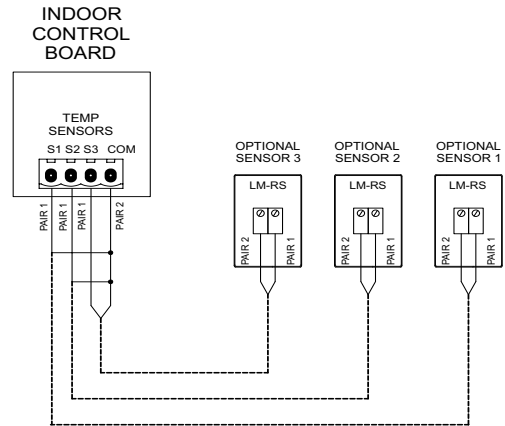

AERSS Optional Duct Sensor Wiring Connections

REMOTE SENSOR WIRING

- PAIR 1: - BLUE / BLUE-WHITE
- PAIR 2: - ORANGE / ORANGE-WHITE
- PAIR 3: - GREEN / GREEN-WHITE
- PAIR 4: - BROWN / BROWN-WHITE

NOTE:

- PAIR 1 AND 2 USED FOR ILLUSTRATION PURPOSES ONLY.
- CUT OFF AND TERMINATE ANY UNUSED PAIRS TO ENSURE NO WIRING IS LEFT EXPOSED.

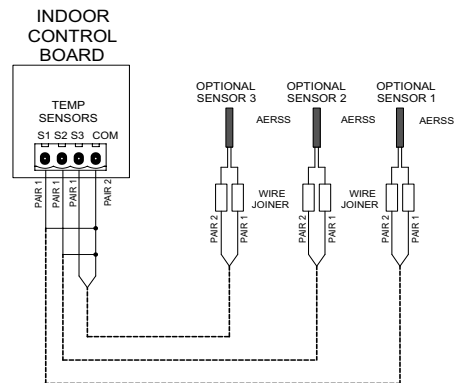

Wiring Diagram 72kW

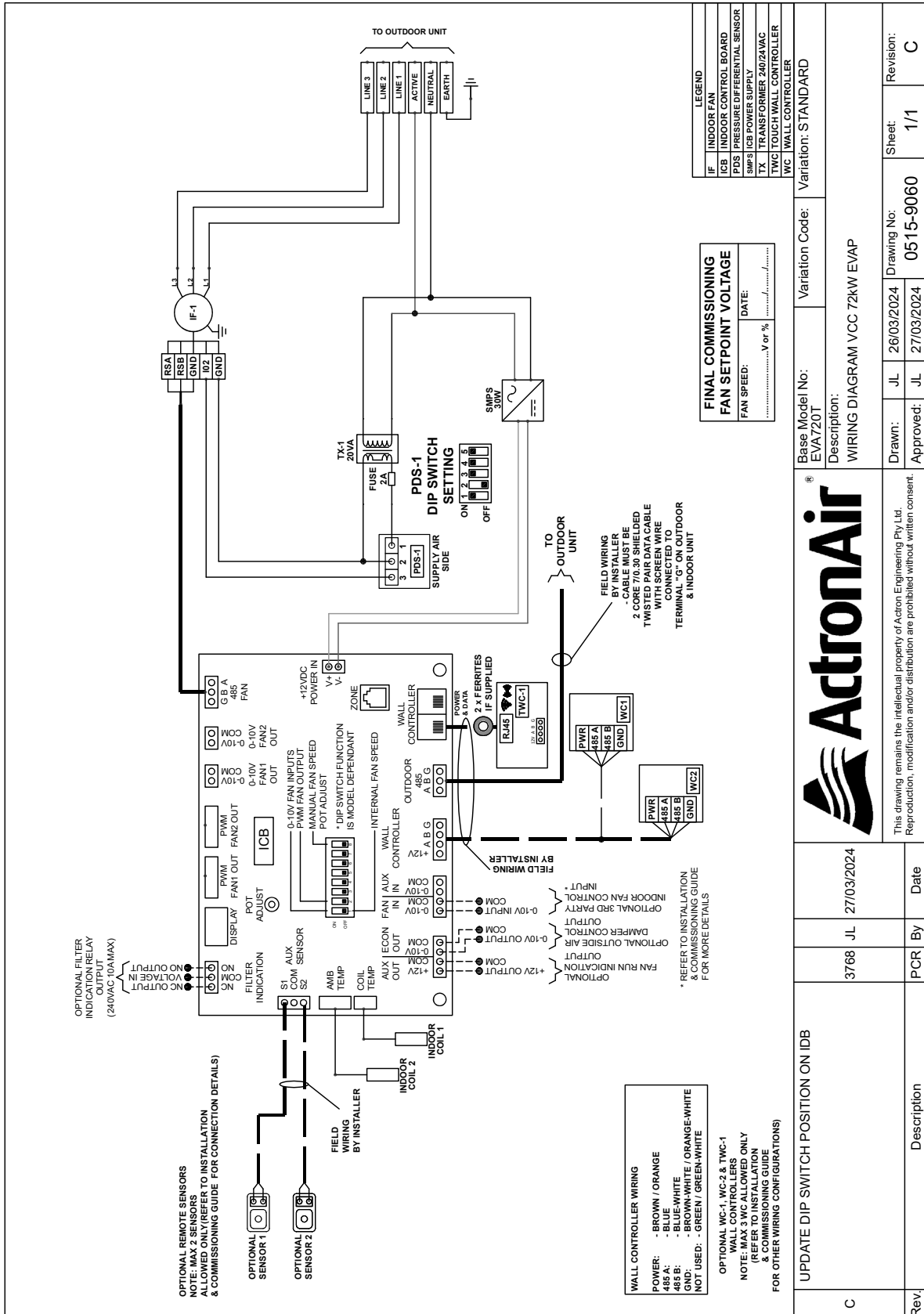

3768 JL 27/03/2024

Rev	Description	PCR	By	Date
C	UPDATE DIP SWITCH POSITION ON IDB			

Base Model No: EVA7Z0T	Variation Code: Variation: STANDARD
Description: WIRING DIAGRAM VCC 72kW EVAP	
Drawn: JL 26/03/2024	Drawing No: 0515-9060
Approved: JL 27/03/2024	Sheet: 1/1
	Revision: C

This drawing remains the intellectual property of Actron Engineering Pty Ltd. Reproduction, modification and/or distribution are prohibited without written consent.

Wiring Diagram 85kW

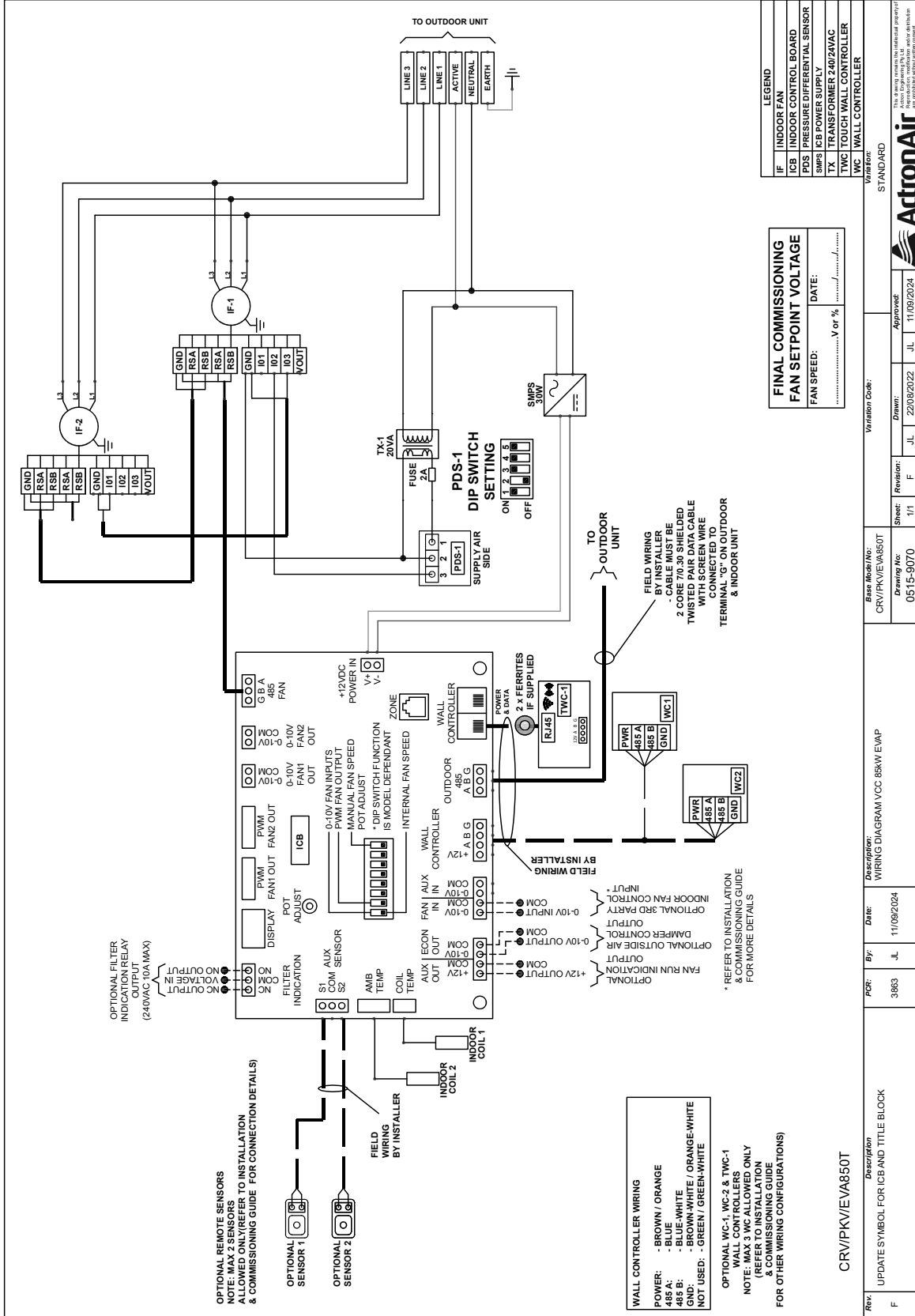

Wiring Diagram 96kW

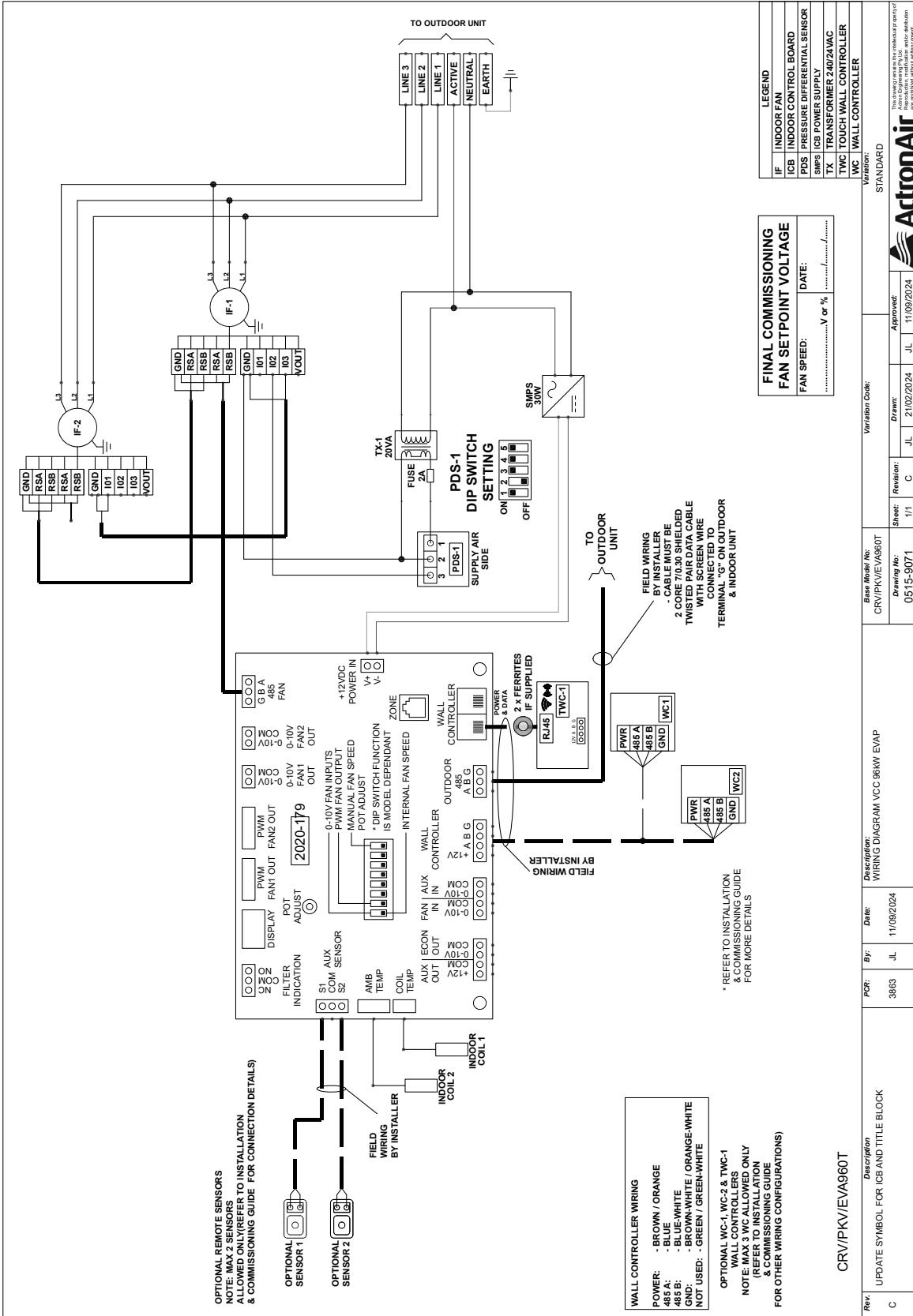

Configuring and Commissioning Setup

Menu and Navigation

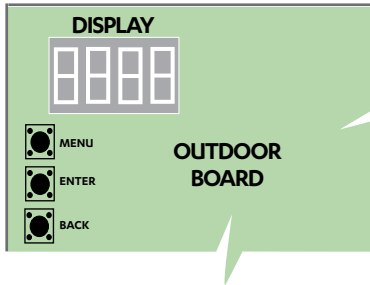

MENU Scroll through the items at the same menu level. Increment the value being set.

ENTER Go into the selected menu. Lock in selected value.

BACK Go back to the parent menu. Press and hold to go back to main menu.

* Family and Capacity are the representative values only and may vary depend on the model purchased as seen below table. **Do not change setting.**

diS (Display)	Display system's status and settings		
SEr (Service)	Service use only		
SEt (Settings)	cnFg	F 06 = Family*	
		C072 = Capacity*	
		Cir.X (Circuit Selection)	Cir.1 = Circuit - 1 (default)
			Cir.2 = Circuit - 2
			Cir.3 = Circuit - 3
			Cir.4 = Circuit - 4
		Ct.X (Controller Selection)	Ct. 0 = 3rd Party
			Ct. 1 = Wall Control (default)
			Ct. 2 = Basic BMS
			Ct. 3 = Wall Control + Basic BMS
	CtrS	Ct. 4 = Advanced BMS	
		Ct. 0 = 3rd Party	
		Ct. 1 = Wall Control (default)	
		Ct. 2 = Basic BMS	
		Ct. 3 = Wall Control + Basic BMS	
	iduS	Ct. 4 = Advanced BMS	
		FP1 = IDU Fan Low PWM setting	
		FP2 = IDU Fan Med PWM setting	
		FP3 = IDU Fan High PWM setting	
		Fr1 = IDU Fan Low RPM setting	
		Fr2 = IDU Fan Med RPM setting	
		Fr3 = IDU Fan High RPM setting	
		FPd = IDU Fan Defrost PWM setting	
FPc = IDU Reduced Airflow PWM setting			
FiL = IDU Fan Filter Hours setting			
Econ = IDU Econ 0-10V Output setting			
FnSE = Indoor Fan Setting			
run	no = Indoor Fan and Compressor (default)		
	YES = Compressor only		
odFS	odHS = OD Fan External Static		
qS	CCS = Cooling compressor speed		
	HCS = Heating compressor speed		
	CCT = Cooling mode critical temp. condition.		
	HCT = Heating mode critical temp. condition.		

Continuation of SEt (Settings)

SEt (Settings)		Continuation of SEt (Settings)	
SEt (Settings)	ECn	On = Group Control enabled	
		Off = Group Control disabled (default)	
	ECoE	oAdC = Outside air damper enable	
		oAdo = Outside air damper On Off	
		ECEo = Economiser control enable	
		EHCE = Humidity control enable	
		EHCo = Humidity control mode	
		EHCS = Humidity sensor source	
		CCE = CO2 control enable	
	ECoS	Etd = Economiser temperature difference	
		EoLt = Economiser outside min temp	
		EoHt = Economiser outside max temp	
		EoLd = Economiser outside min damper	
		EoHd = Economiser outside max damper	
		EoHH = Economiser outside max humidity	
		EoHn = Economiser outside max moisture	
		EodP = Economiser outside max dew point	
		EoHE = Economiser outside max enthalpy	
		EEd = Economiser enthalpy delta	
	dSH	ELPL = Economiser CO2 p1	
		EHPL = Economiser CO2 p2	
		ELdP = Economiser CO2 damper p1	
		EHdP = Economiser CO2 damper p2	
dSH	dSHE = De-superheater enable		
	dHdS = De-superheater enable-heating only		
dCt	dCt = De-superheater critical temp.		
ECS	on = Compressor Staggering Enabled (default)		
	oFF = Compressor Staggering Disabled		
AFC	(Indoor Fan K-Factor)	425 = 96kW	
		425 = 85kW	
		545 = 72kW	
HtSt	on = Hot Start enabled (for BMS only)		
	oFF = Hot Start disabled (default)		

Family and Capacity Table							
Model		CRV720T	CRV850T	CRV960T	PKV720T	PKV850T	PKV960T
Family	Type	Capacity (kW)					
F 06	Split	C072	C085	C096	-	-	-
F 07	Package	-	-	-	C072	C085	C096

Configuring Compressor and Capacity(cnFg)

Configure the compressor type and capacity. The unit is factory configured. **Do not change this setting.**

Configuring Control Source (CtrS)

This commissioning is applicable for BMS and third party control.

Configurable settings are as follows:

Third Party Control

The unit can be controlled by non-ActronAir wall control. To do this, **CtrS** on the Outdoor Board has to be set to **Ct. 0**. For connection details, see the wiring diagram supplied with the outdoor unit.

Wall Control

ActronAir offers NEO, LR7-1 and LC7-2, wall controls that can control the available features and maximise the function and operation of the air conditioner. To do this, **CtrS** on the Outdoor Board must be set to **Ct. 1**.

Basic BMS

The unit can be connected to a network through a BMS card (ICUNO-MOD). This allows the unit to be operated in the same way the as the NEO, LR7-1 and LC7-2 does. To do this, **CtrS** on the Outdoor Board must be set to **Ct. 2**.

Wall Control + Basic BMS

The unit can be connected to a network (Basic BMS) and at the same time be controlled using the NEO, LR7-1 or LC7-2 controller. Priority will be given to the most recent command. To do this, **CtrS** on the Outdoor Board must be set to **Ct. 3**.

Advanced BMS

The unit can be connected for system that requires customised functions not included in the existing software or logic in the Outdoor Board but still retaining the safety logic. To do this, **CtrS** on the Outdoor Board must be set to **Ct. 4**.

Optional BMS Control

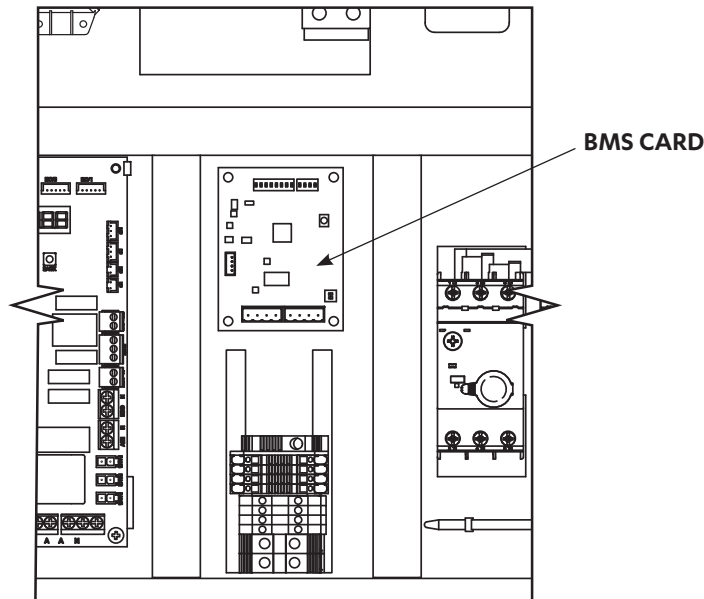

NOTE

- Refer to ICUNO-Mod Installation and Commissioning Guide for more information.
- BMS card will be connected to ODU board Stage 1

BMS PART NUMBERS		
BMS Connection Type	Kit Part Number *	Order Form
MODBUS 485	ICUNO-MOD	Not required

* To be purchased separately.

DANGER

Hazardous Voltage !

- Always make sure that all power supply, including remote controls, are disconnected before performing maintenance. Observe proper LOCK-OUT / TAG-OUT (LOTO) procedures to ensure that power cannot be inadvertently energised. Failure to disconnect power before maintenance procedures can result in serious injury or death.
- Follow all electrical safety precautions when exposed to live electrical components.
- Only qualified technicians are allowed to work on electrical circuits.
- All electrical wiring must be in accordance with the relevant electrical authority rules and regulations.

CAUTION

STATIC SENSITIVE ELECTRONIC DEVICES !

- DO NOT handle electronic devices unless you are wearing an Anti-Static Wrist Strap that is connected to a GOOD EARTH. Failure to protect the electronic devices from static electricity may cause unreparable damage.
- Static damaged electronic devices are NOT COVERED for replacement under warranty.

Accessing Service and Technical via NEO

Special options are available via Advance Option menu. This must be accessed through Service and Technical section. Follow the steps as shown below:

1. To access the Menu, touch on the hamburger icon (☰) on the NEO Controller.

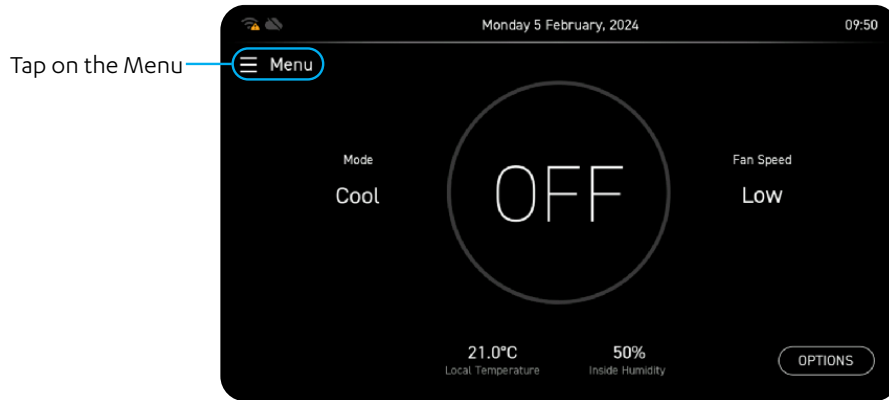

2. On the Main Menu, Select the **Service & Technical** Section.

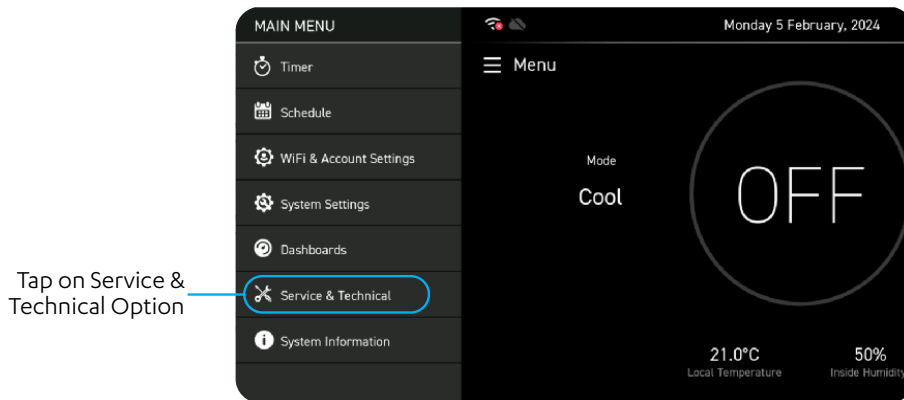

3. An Access Code will be asked. Provide Access Code - **7378**

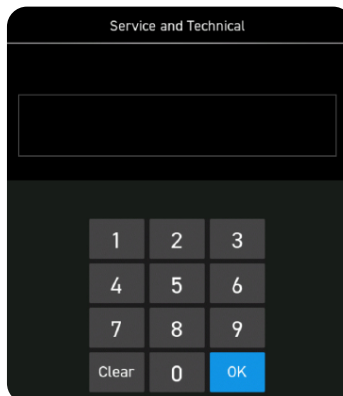

4. The **Service & Technical** Section screen is as below:

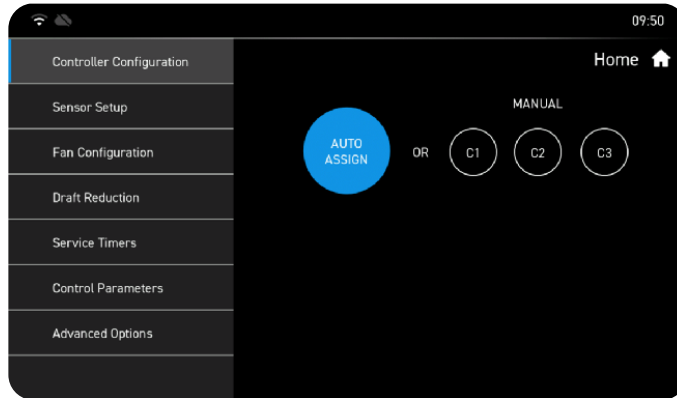

After Hours Logic with Timeclock (Scheduler)

After Hours is the duration (in minutes) in which the unit will turn ON when the After Hours is set. By default, this is set to 0 min. The Minimum Settable Value is 1 min and the Maximum Settable Value is 120 mins. Setting this will be accessible via Service & Technical menu.

Set up the After Hours via the Control Interface as follow:

1. In the **Service and Technical** Section, select the **Advanced Options**.

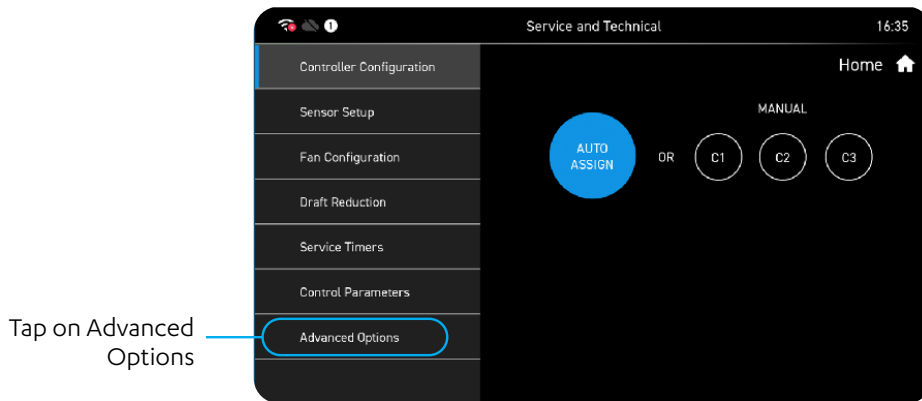

2. In the Advanced Options, select **Enable Commercial Application Mode** by tapping on the check box.

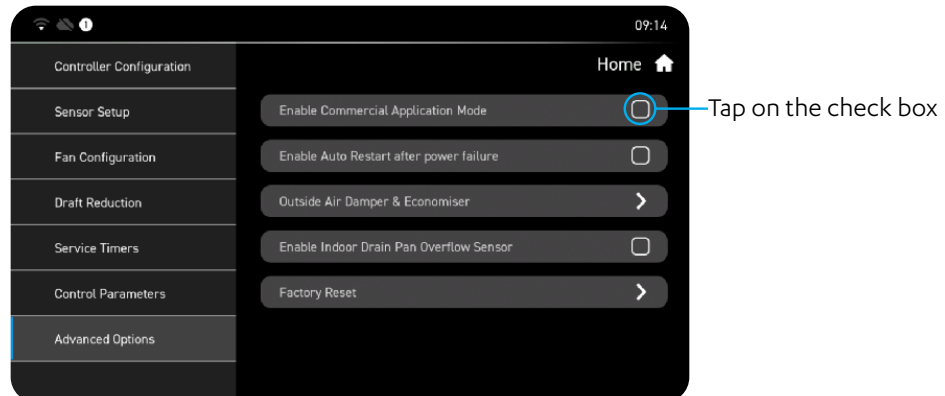

3. Touch on the **Options** tab to get to the next slide.

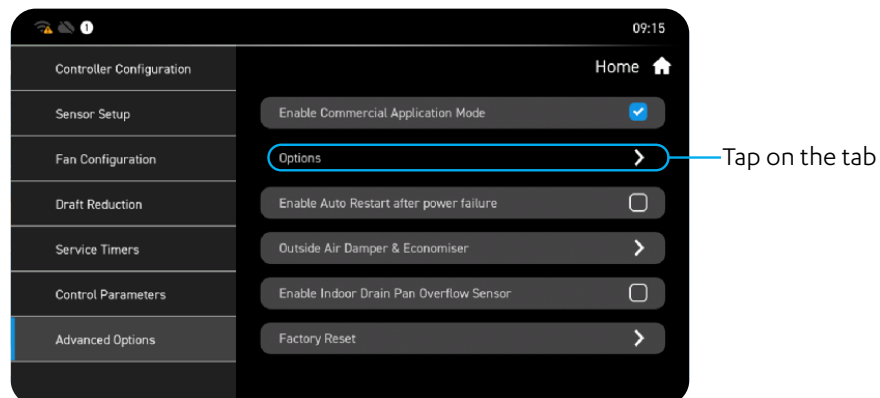

4. Activate the **After Hours Mode** by tapping on the check box.

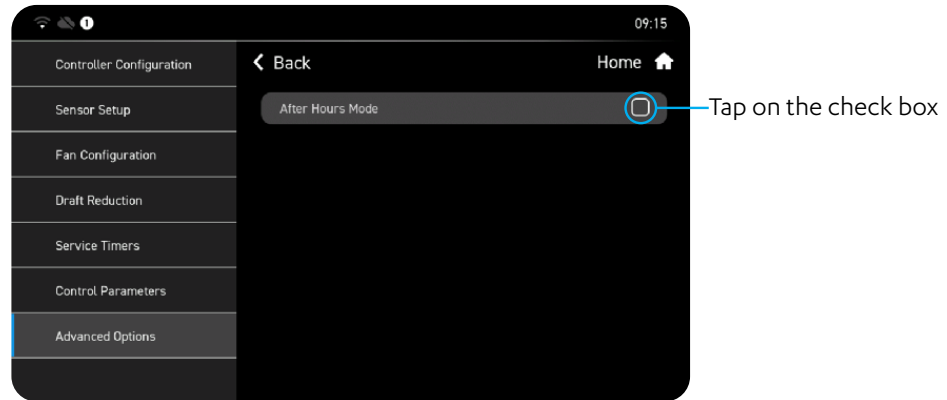

5. Make necessary changes as the settings will be automatically saved. Touch on the **Home** button on the top right corner to go back to the **Home** screen.

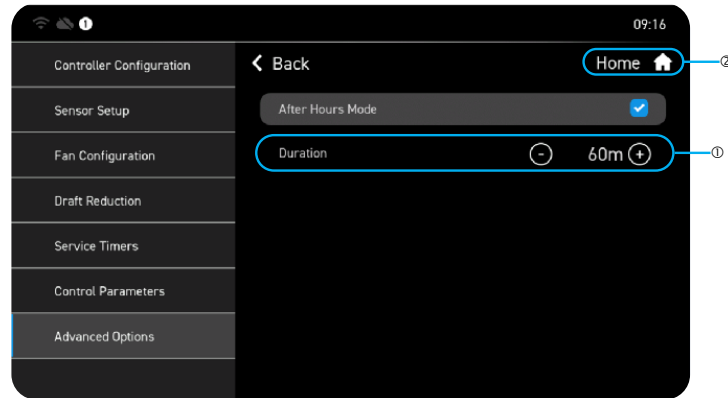

6. **Home** screen.



7. To view the new setting of the **After Hours Mode**, touch the **Menu** button on the **Home** screen.

Tap on the Menu

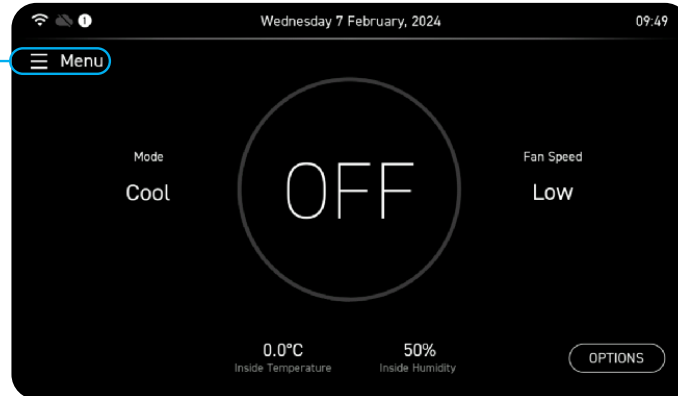

8. Select the **After Hours** and the new settings will appear.

Tap on After Hours

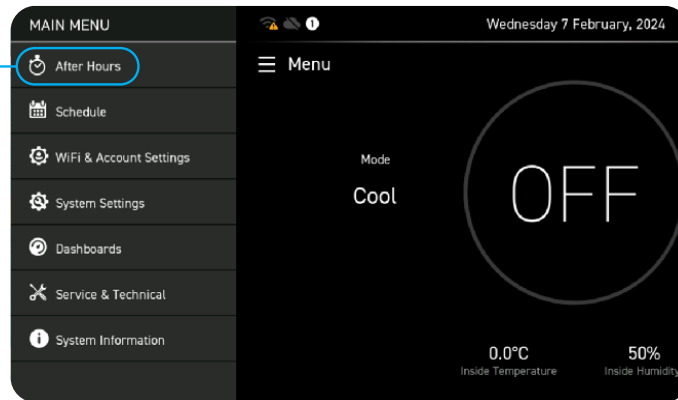

Filter Alarm Configuration

This gives the user an option to Enable and set the Air Filter Alarm .
The setting is accessible via Service & Technical menu.

Filter Alarm Configuration

The filter timer can be set via the Control Interface as follow:

1. In the **Service & Technical** Section, select the **Service Timers**.

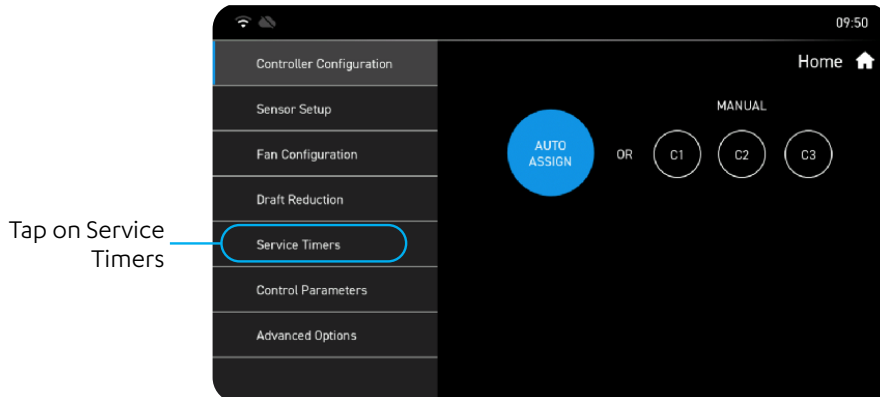

2. In the Service Timers, select **Fan Filter Alarm Configuration** by tapping on the tab

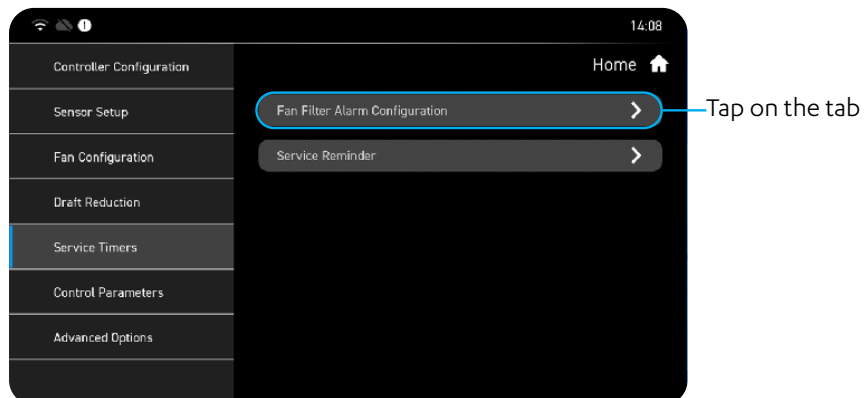

3. Make sure the **Timer Mode** is ticked. Make necessary changes on the **Duration** by clicking the ⊖ or ⊕ buttons. Settings are automatically saved.

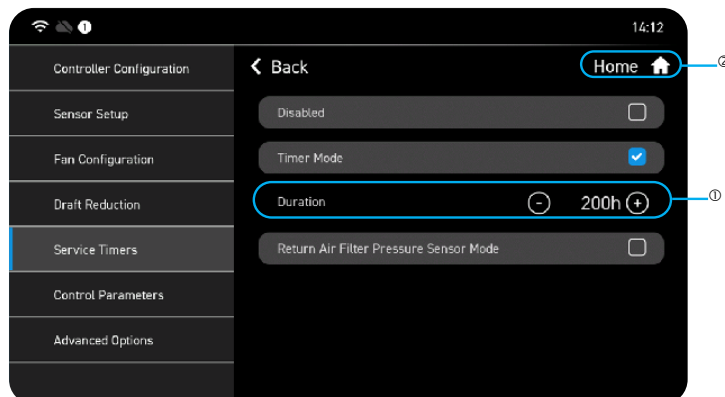

4. Click on the **Home** button on the top right corner to go back to the home screen.

Bluetooth Commissioning Tool

This application will allow end users to set up and configure VCC products by using **Actron Link** Application.

With its simple and easy to use design, this application makes advanced linking functions easy for end-users. The integrated functions and remote access capabilities ensure it is easy to install and service.

The **Actron Link** application also allows the user to retrieve the product information.

To access the **Instruction Manual (9590-3037-01)**, scan the QR Code on the Box of the Bluetooth Commissioning Tool or visit docs.actronair.com.au.

Demand Response Management

These products are compliant to AS/NZS 4577.3.1:2012

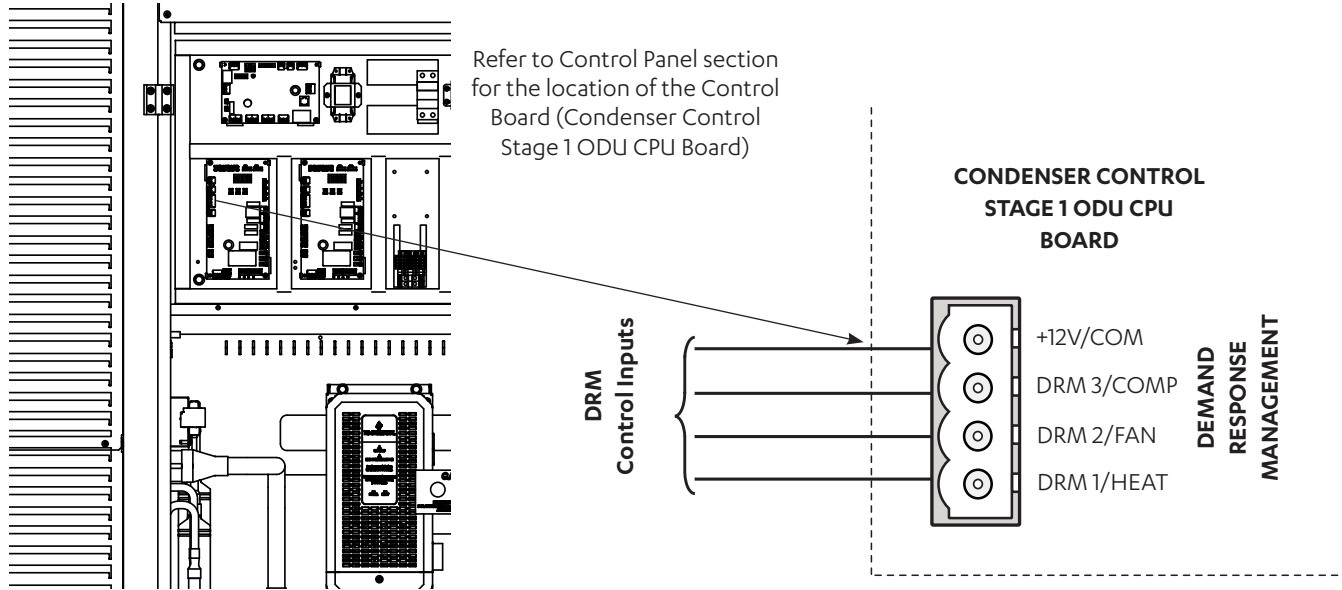

1. Route DRM input cables into the Unit (as per previous wiring installation procedure).
2. Connect cables into terminals (as per wiring diagram provided with the unit).

Demand Management Mode	Description Of Mode Allowable Range (%)	Operating Mode
DRM1	Compressor Off Mode	Compressor <u>ONLY</u> will cycle Off and remain Off for the entire Demand Response event. All other functions will operate as normal (i.e. Indoor Fan)
DRM2	Maximum 50% power use mode with 0 to <50% allowable power use range	Compressor 0 to <50% operation range for the total Demand Response event.
DRM3	Maximum 75% power use mode with 0 to <75% allowable power use range	Compressor 0 to <75% operation range for the total Demand Response event.

DEMAND RESPONSE ENABLING DEVICE CIRCUIT DIAGRAM

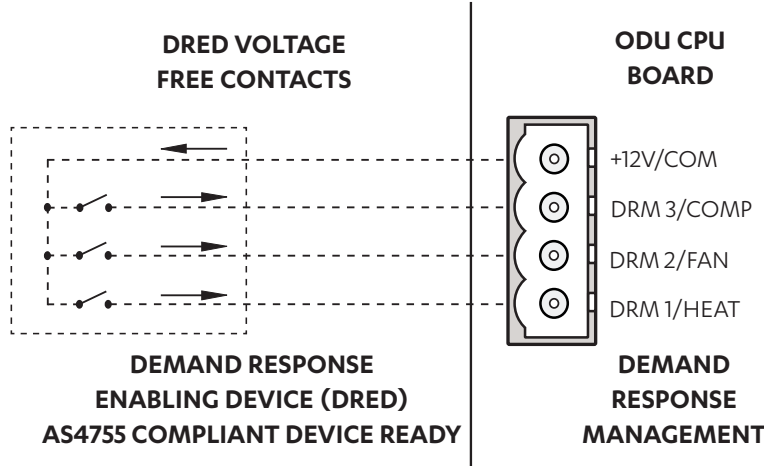

NOTES

- Demand Response Management is not applicable when using third party control.
- Contact your electricity authority to install and activate DRED.
- All drawings are for illustration purposes only. Actual unit may vary depending on the model.

Third Party Control Input (Indoor and/or Outdoor Board)

This option allows Fan, Compressor and Reversing Valve to be controlled by a Third Party Control. There are two ways on how the Indoor Fan may be controlled, using 0-10V Analogue Input or Fixed Indoor Fan Speed.

NOTE

- Demand Response Management (DRM) is not available if Third Party Control Option is used.
- Ensure control source has been configured for Control Mode 0.
 1. On the Outdoor Board, set Control Source to Third Party. Using the MENU and the ENTER buttons, navigate to SEt (Settings) --> CtrS (Control Source).
 2. Use the MENU button to navigate to 0 to select Third Party Control as the control source. Press the ENTER button to save the setting.

0-10V Analogue Input for Compressor and Indoor Fan

Indoor Fan Connection (Indoor Board)

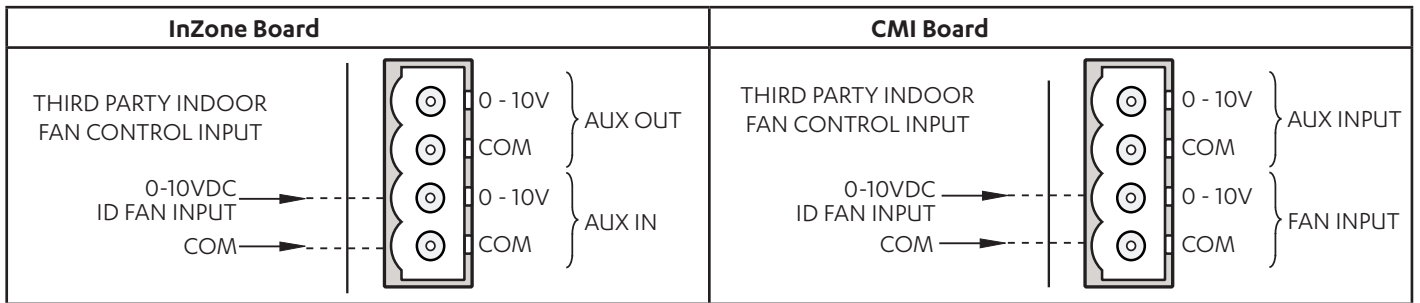

Indoor Fan Setting (Indoor Board)

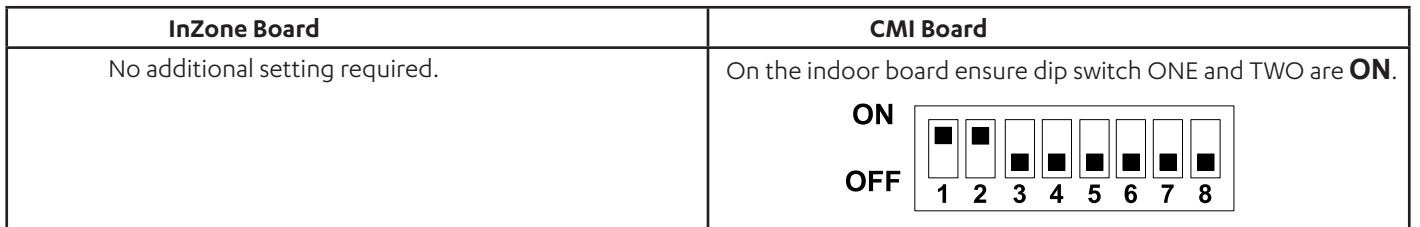

Input (DC)	Output	Fan Status
0.0V to 0.99 V	0%	Off
1.0V to 1.49 V	0 or 20%	Off or On
1.5V to 9.5 V	20% to 100%	On
9.5V to 10 V	100%	On

Compressor and Reversing Valve Connection (Outdoor Board)

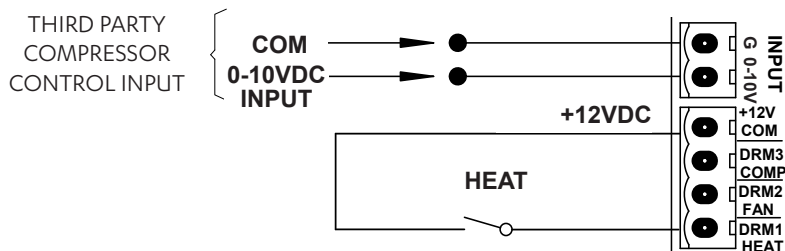

Input (DC)	Output	Compressor Status
0 - 0.99 V	0%	Off
1 - 1.49 V	0 or 20%	Off/On (hysteresis)
1.5 - 9.5 V	20% to 100%	On
9.5 - 10 V	100%	On

NOTES

- As the compressor turns ON and the Indoor fan signal is not available then indoor fan will start to run on medium PWM speed.
- Indoor fan low and high PWM limits depends upon the model. Refer to Indoor Fan Table and Fan Curve Section.
- The Voltage can be linearly interpolated using the above table to determine the desired PWM or unit output.
- Only applicable for CMI board: If the compressor turn ON, during reduced fan operation, the controller will increase the fan speed to the "low PWM fan limit" if it is running less than the low PWM Limits.

0-10V Analogue Input for Compressor with Fixed Indoor Fan Speed

This feature allows for the Indoor Fan to be controlled externally (ON/OFF only).

Indoor Fan Connection (Indoor Board) AS IS

When using fixed speed indoor fan, there would be no wiring onto the InZone nor CMI.

Indoor Fan Setting (Indoor Board)

InZone Board	CMI Board
No additional setting required.	On the indoor board ensure that only dip switch TWO is ON .

Fan, Compressor and Reversing Valve Connection (Outdoor Board)

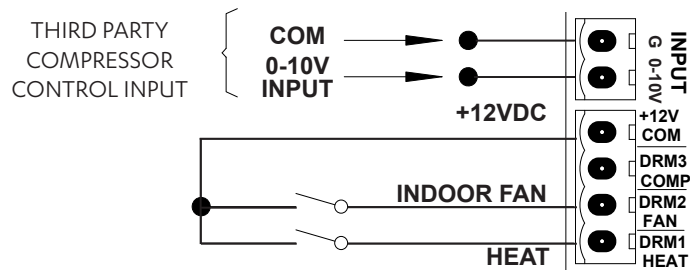

NOTES

- As the compressor turns ON and the Indoor fan signal is not available then indoor fan will start to run on medium PWM speed.
- Indoor fan operation when fan signal is available:
 - Compressor ON : Indoor fan will run on medium speed.
 - Compressor OFF :
 - » CMI: Indoor fan will run on reduce airflow operation.
 - » InZone: Indoor fan is dependent of the controller setting.

Input for Fixed Compressor with Fixed Indoor Fan Speed

This feature allows for both Compressor and Indoor Fan to be controlled externally (ON/OFF only).

Indoor Fan Setting (Indoor Board)

InZone Board	CMI Board
No additional setting required.	On the indoor board ensure that only dip switch TWO is ON .
	<p>ON</p>  <p>OFF</p>

Fan, Compressor and Reversing Valve Connection (Outdoor Board)

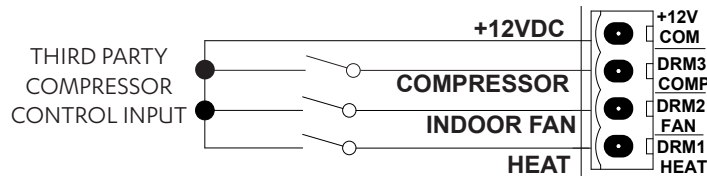

NOTES

- As the compressor turns ON and the Indoor fan signal is not available then indoor fan will start to run on medium PWM speed.
- Indoor fan operation when fan signal is available:
 - Compressor ON : Indoor fan will run on medium speed.
 - Compressor OFF :
 - » CMI: Indoor fan will run on reduce airflow operation
 - » InZone: Indoor fan is dependent of the controller setting.
- Compressor turns on with 100% speed request.
- Although the compressor will have 100% speed request, the speed may vary depending on compressor safety requirements. This will be shown on the outdoor board display.

0-10V Analogue Input for Indoor Fan with Fixed Speed Compressor

This feature allows for the compressor to be controlled externally (ON/OFF only).

Indoor Fan Connection (Indoor Board)

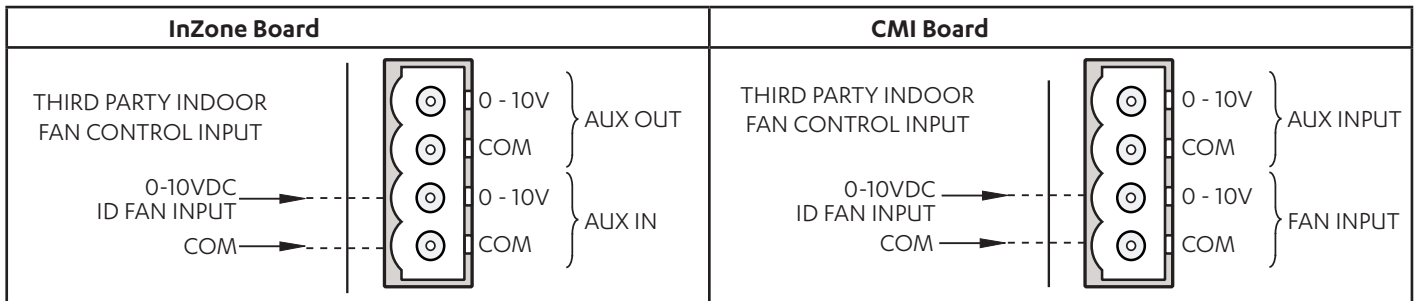

Indoor Fan Setting (Indoor Board)

InZone Board	CMI Board
No additional setting required.	On the indoor board ensure dip switch ONE and TWO are ON .
	<p>ON</p>  <p>OFF</p>

Input (DC)	Output	Fan Status
0.0 V to 0.99 V	0%	Off
1.0 V to 1.49 V	0 or 20%	Off or On
1.5 V to 9.5 V	20% to 100%	On
9.5 V to 10 V	100%	On

Fan, Compressor and Reversing Valve Connection (Outdoor Board)

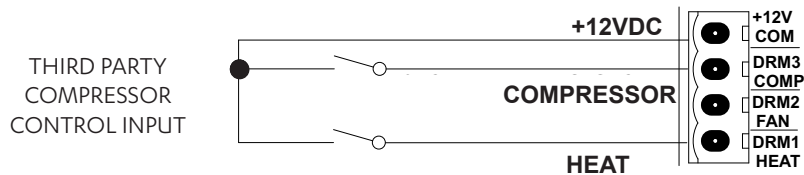

NOTES

- As the compressor turns ON and the Indoor fan signal is not available then indoor fan will start to run on medium PWM speed.
- If the compressor turn ON, during reduced fan operation, the controller will increase the fan speed to the "low PWM fan limit" if it is running less than the low PWM Limits.
- Indoor fan low and high PWM limits depends upon the model.
- The Voltage can be linearly interpolated using the above table to determine the desired PWM or unit output.
- Compressor turns on with 100% speed request.

Run and Fault Indication Output (Outdoor Board)

To activate, the unit must be wired as illustrated below. If required, a fault output connection terminal is also available to show any error/fault with the a/c system. RUN/FAULT relay outputs (230VAC/5A MAX) connection.

Run Indication

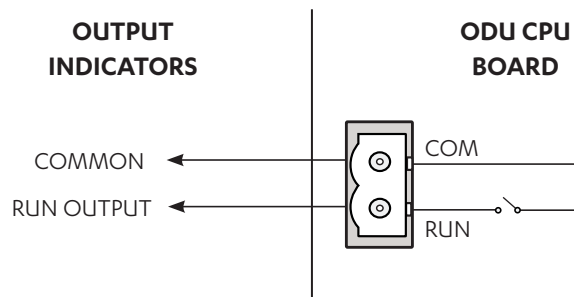

Run Output is configurable to indicate that the unit is running. There are two configurations in which this can be set:

- Either the compressor or the Indoor Fan only is running
- Only Compressor is running.

By default, this is set to turn on when either indoor fan or compressor is operating. To set up to compressor run indication only, in OD Board Menu follow below steps.

1. Using the **MENU** and the **ENTER** Buttons on the outdoor PCB, navigate to **SEt** (Settings) → **run** (Unit Operation Indicator Settings).

- If required, press **MENU** to navigate to **YES**.

Fault Indication

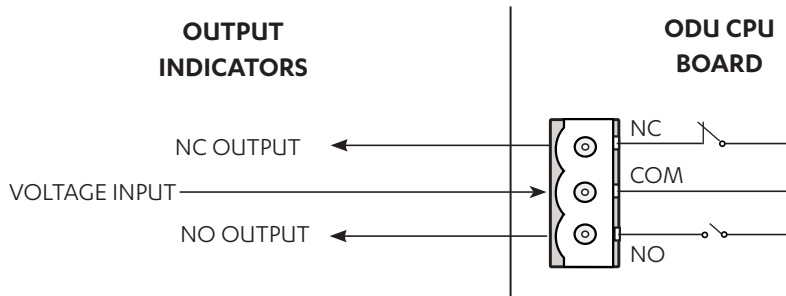

To indicate any system fault, outdoor controller will provide a signal through the Fault Indication relay. An installer can use either NC or NO output as per their requirements.

Remote On/Off

To activate, the unit must be wired as illustrated below. This will enable unit to be turned ON and OFF from the Outdoor board.

NOTES

The system must be operating in Wall Controller only (control mode 1) or BMS + Wall Controller (control mode 3) for this function to work.

- On the Outdoor Board, set Control Source to Third Party. Using the MENU and the ENTER buttons, navigate to SEt (Settings) --> CtrS (Control Source).
- Use the MENU button to navigate to "1" or "3" to select "Wall Controller only" or "BMS + Wall Controller" as the control source. Press the ENTER button to save the setting.

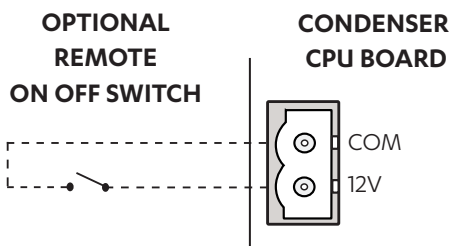

Turning the system On and Off by remote method

Turning the system On	Status 1: The system is Off and the remote switch/relay has been left in the open position. <ol style="list-style-type: none"> Close remote switch/relay. System will start in approximately in 30 seconds.
	Status 2: The system is Off and the remote switch/relay has been left in the closed position. <ol style="list-style-type: none"> Open remote switch/relay for a minimum of 5 seconds. Close remote switch/relay. System will start in approximately in 30 seconds.
Turning the system Off	Status 3: The system is On and the remote switch/relay has been left in the closed position. <ol style="list-style-type: none"> Open remote switch/relay. System will turn Off in approximately in 30 seconds.
	Status 4: The system is On and the remote switch/relay has been left in the open position. <ol style="list-style-type: none"> Close remote switch/relay for a minimum of 5 seconds. Open remote switch/relay. System will turn Off in approximately in 30 seconds.

Fan Performance Data and Curve

EVA720T

FAN DATA																					
AIRFLOW (l/s)		EXTERNAL STATIC PRESSURE (Pa)																			
		50		100		150		200		250		300		350		400		450		500	
		% SPD	W	% SPD	W	% SPD	W	% SPD	W	% SPD	W	% SPD	W	% SPD	W	% SPD	W	% SPD	W	% SPD	W
1*	1000	33	174	41	275	49	435	55	561	60	687	65	834	69	963	73	1121	77	1291	81	1461
	1500	40	260	47	395	53	544	58	691	63	856	68	1037	72	1203	75	1341	79	1525	83	1709
2*	1700	43	313	50	465	55	623	60	772	65	953	70	1138	74	1323	77	1468	81	1676	84	1864
	2000	48	394	54	570	59	741	63	893	68	1098	72	1289	76	1502	79	1658	83	1902	86	2095
	2500	56	574	61	770	66	988	70	1172	74	1398	77	1573	81	1818	84	2020	88	2297	92	2577
	3000	65	846	70	1088	73	1272	77	1517	81	1771	84	1985	87	2212	91	2537	94	2809	97	2898
3*	3500	74	1205	78	1464	81	1667	84	1886	88	2205	91	2468	94	2769	96	2970	98	3170		
	3800	79	1477	83	1726	86	1961	89	2221	92	2529	95	2633	98	3103	99	3229				
	4000	83	1658	86	1901	89	2157	92	2444	95	2745	97	2743	MOTOR /BLOWER LIMIT							
	4500	92	2258	95	2563	97	2562														

- * 1 Airflow during compressor OFF operation.
- 2 Airflow during Safe Mode, see the fan curve for detailed information.
- 3 Capacity Selection Range - See the Airflow Correction Multiplier for details.

NOTES:

% Speed = Indoor Fan Speed Control Setting, in percent

W = Indoor Fan Power, Watts

 Bold data in the box indicates Factory Default Setting.

High speed limit may be outside the fan curves at lower static condition which needs to be taken care while operating the unit.

Indoor Fan PWM Limits	
High Spd. Limit (%)	99
Low Spd. Limit (%)	33

EVA720T : Third Party Application Fan Curve

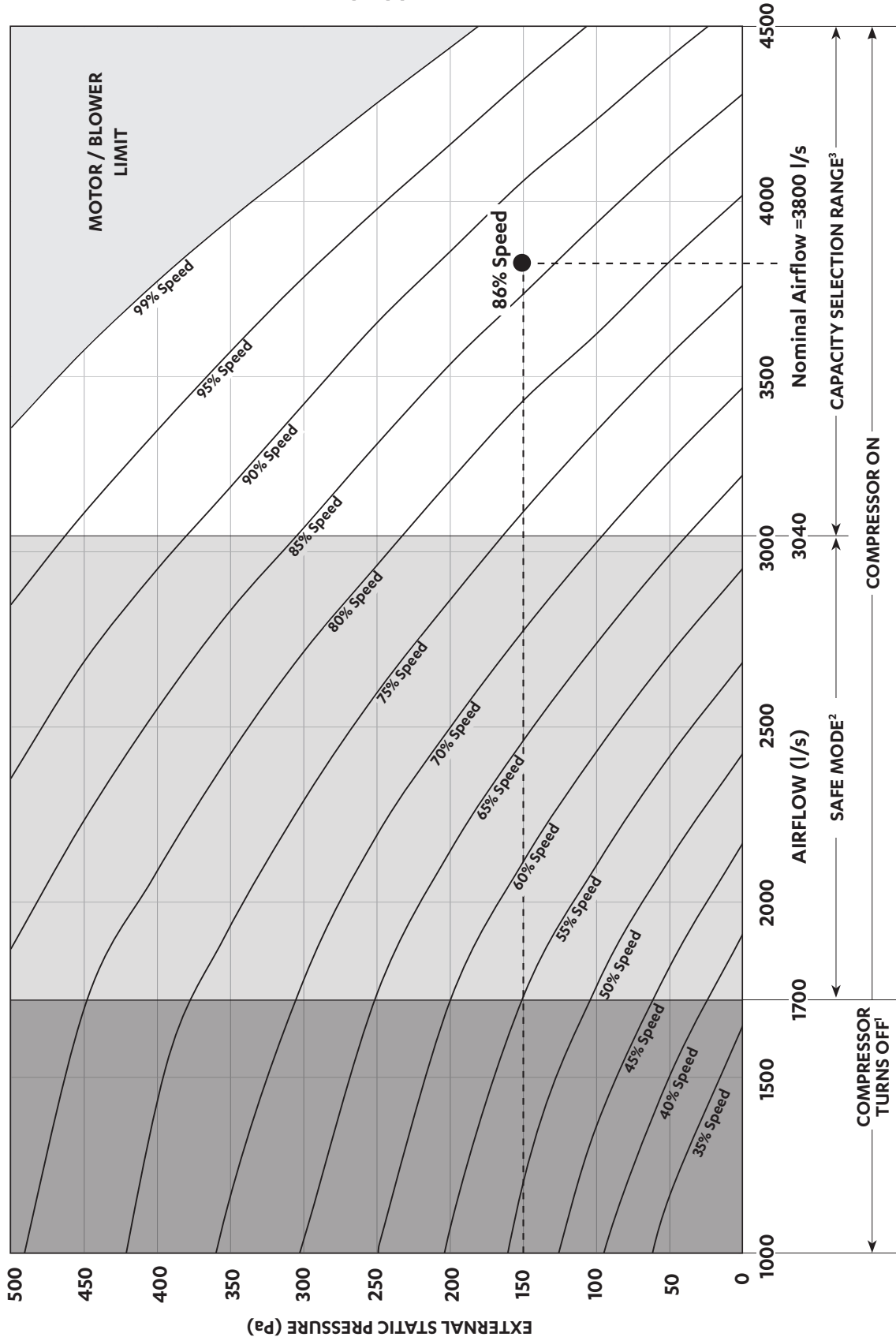

NOTE

- 1 When the airflow goes below the lower limit of the Safe Mode, the compressor turns off; the fan will continue to run.
 - 2 System safety logic may be activated
- Fan Performance Data and Fan Curve shown is at dry coil and with no air filters installed. Consider external static pressure drop specific to your design requirements. Airflow should be reduced with respect to the moisture content in the air. Please review filter manufacturer for application. 2.5 m/s face velocity point will occur outside the application range.

EVA850T

FAN DATA																			
AIRFLOW (l/s)	100		150		200		250		300		350		400		450		500		
	% PWM	W	% PWM	W	% PWM	W	% PWM	W	% PWM	W	% PWM	% PWM	% PWM	W	% PWM	% PWM	% PWM	% PWM	
1*	1200	40	349	46	518	52	697	57	875	62	1072	66	1250	70	1460	74	1696	78	1936
	1500	41	410	47	574	53	775	58	968	63	1185	67	1384	71	1609	75	1856	79	2103
2*	2000	44	515	50	718	55	912	61	1179	65	1380	69	1611	73	1870	77	2181	80	2447
	2500	48	650	53	851	58	1081	63	1337	67	1574	71	1844	75	2153	79	2475	82	2717
	3000	52	790	57	1038	62	1316	66	1562	70	1836	74	2152	77	2404	81	2752	84	3012
	3500	57	993	62	1285	66	1547	70	1841	73	2098	77	2457	80	2738	83	3039	87	3438
3*	4000	63	1277	67	1566	70	1802	74	2166	77	2450	80	2740	83	3067	86	3394	89	3721
	4450	68	1522	72	1873	75	2151	78	2464	81	2779	84	3114	87	3485	90	3872	93	4259
	4500	68	1550	72	1907	75	2190	78	2497	81	2815	84	3155	87	3531	90	3925	93	4319
	5000	73	1877	76	2178	80	2612	83	2974	86	3349	88	3617	91	4039	94	4498	96	4650
	5350	77	2140	80	2479	83	2874	86	3266	89	3673	92	4082	94	4427	96	4784	98	5048

- * 1 Airflow during compressor OFF operation.
- 2 Airflow during Safe Mode, see the fan curve for detailed information.
- 3 Capacity Selection Range - See the Airflow Correction Multiplier for details.

NOTES:

% Speed = Indoor Fan Speed Control Setting, in percent

W = Indoor Fan Power, Watts

 Bold data in the box indicates Factory Default Setting.

High speed limit may be outside the fan curves at lower static condition which needs to be taken care while operating the unit.

Indoor Fan PWM Limits	
High Spd. Limit (%)	98
Low Spd. Limit (%)	40

EVA850T : Third Party Application Fan Curve

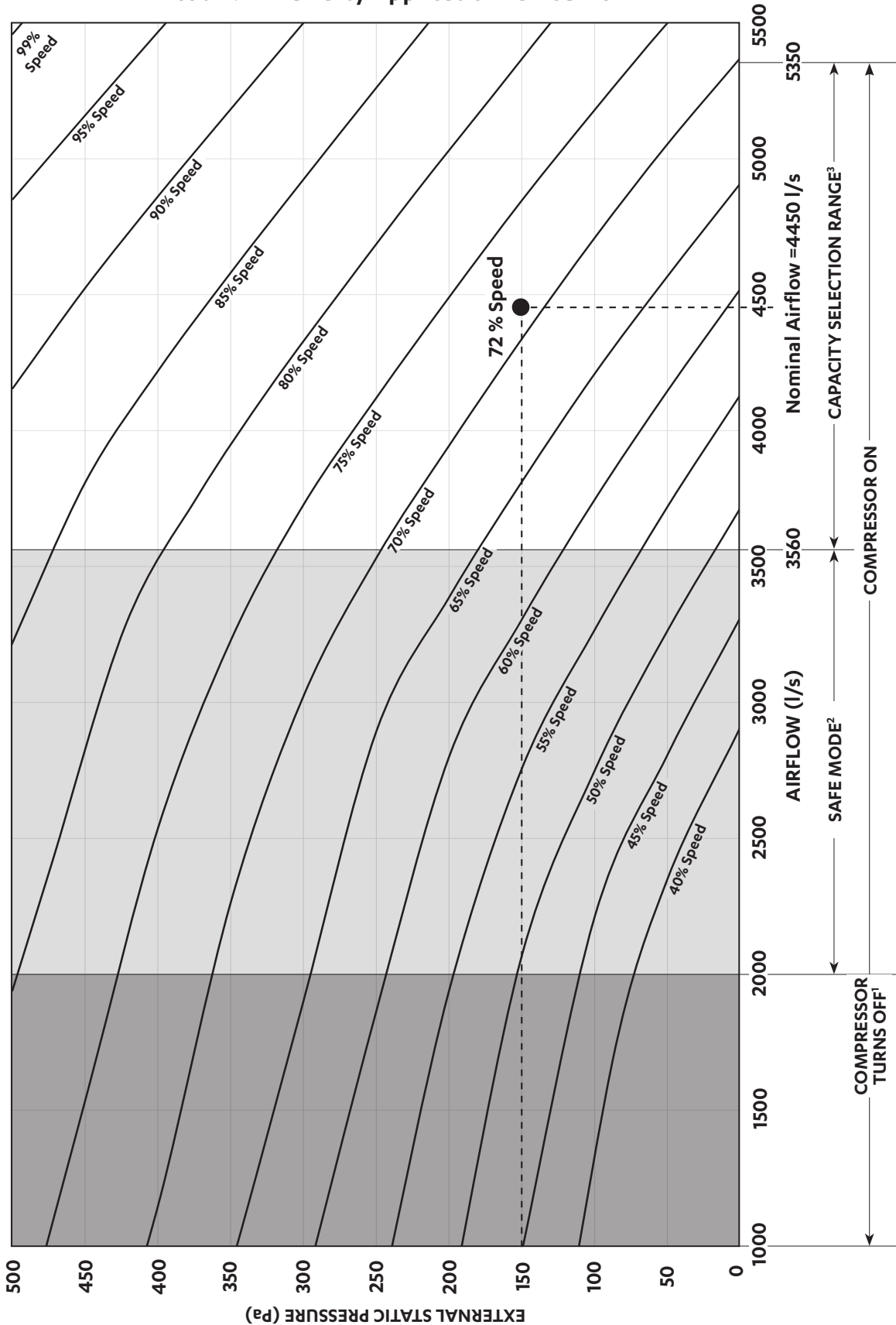

NOTE

- 1 When the airflow goes below the lower limit of the Safe Mode, the compressor turns off; the fan will continue to run.
- 2 System safety logic may be activated

Fan Performance Data and Fan Curve shown is at dry coil and with no air filters installed. Consider external static pressure drop specific to your design requirements. Airflow should be reduced with respect to the moisture content in the air. Please review filter manufacturer for application. 2.5 m/s face velocity point will occur outside the application range.

EVA960T

FAN DATA																			
AIRFLOW (l/s)		EXTERNAL STATIC PRESSURE (Pa)																	
		100		150		200		250		300		350		400		450		500	
		% SPD	W	% SPD	W	% SPD	W	% SPD	W	% SPD	W	% SPD	W	% SPD	W	% SPD	W	% SPD	W
1*	1250	39	389	46	525	51	682	57	882	62	1105	66	1298	70	1520	73	1701	77	1947
	1500	40	407	47	582	52	748	58	979	63	1200	67	1411	71	1650	74	1847	78	2110
	2000	44	525	49	695	54	894	60	1146	65	1402	69	1655	72	1857	76	2150	80	2484
2*	2250	46	578	51	786	56	997	62	1252	66	1507	70	1777	73	1990	77	2299	81	2634
	2500	47	631	53	876	58	1100	63	1359	67	1612	71	1899	74	2123	78	2449	82	2784
	3000	52	815	57	1061	62	1338	66	1599	69	1822	73	2132	77	2473	80	2749	83	3024
	3500	57	1022	62	1315	66	1591	69	1832	73	2165	76	2428	80	2800	83	3125	86	3449
	4000	62	1253	66	1543	70	1878	73	2143	77	2516	80	2813	83	3159	86	3505	88	3736
3*	4500	71	1538	71	1892	75	2262	78	2572	81	2897	84	3251	87	3643	89	3917	92	4328
	5000	76	1959	76	2262	79	2593	82	2957	85	3336	88	3753	91	4190	93	4511	96	4830
	5500	81	2353	81	2727	84	3121	87	3528	89	3803	92	4264	95	4748	97	4746		
	6000	85	2718	85	3131	88	3559	91	4005	94	4490	96	4813	99	5298				

- * 1 Airflow during compressor OFF operation.
- 2 Airflow during Safe Mode, see the fan curve for detailed information.
- 3 Capacity Selection Range - See the Airflow Correction Multiplier for details.

NOTES:

% Speed = Indoor Fan Speed Control Setting, in percent

W = Indoor Fan Power, Watts

 Bold data in the box indicates Factory Default Setting.

High speed limit may be outside the fan curves at lower static condition which needs to be taken care while operating the unit.

Indoor Fan PWM Limits	
High Spd. Limit (%)	99
Low Spd. Limit (%)	39

EVA960T : Third Party Application Fan Curve

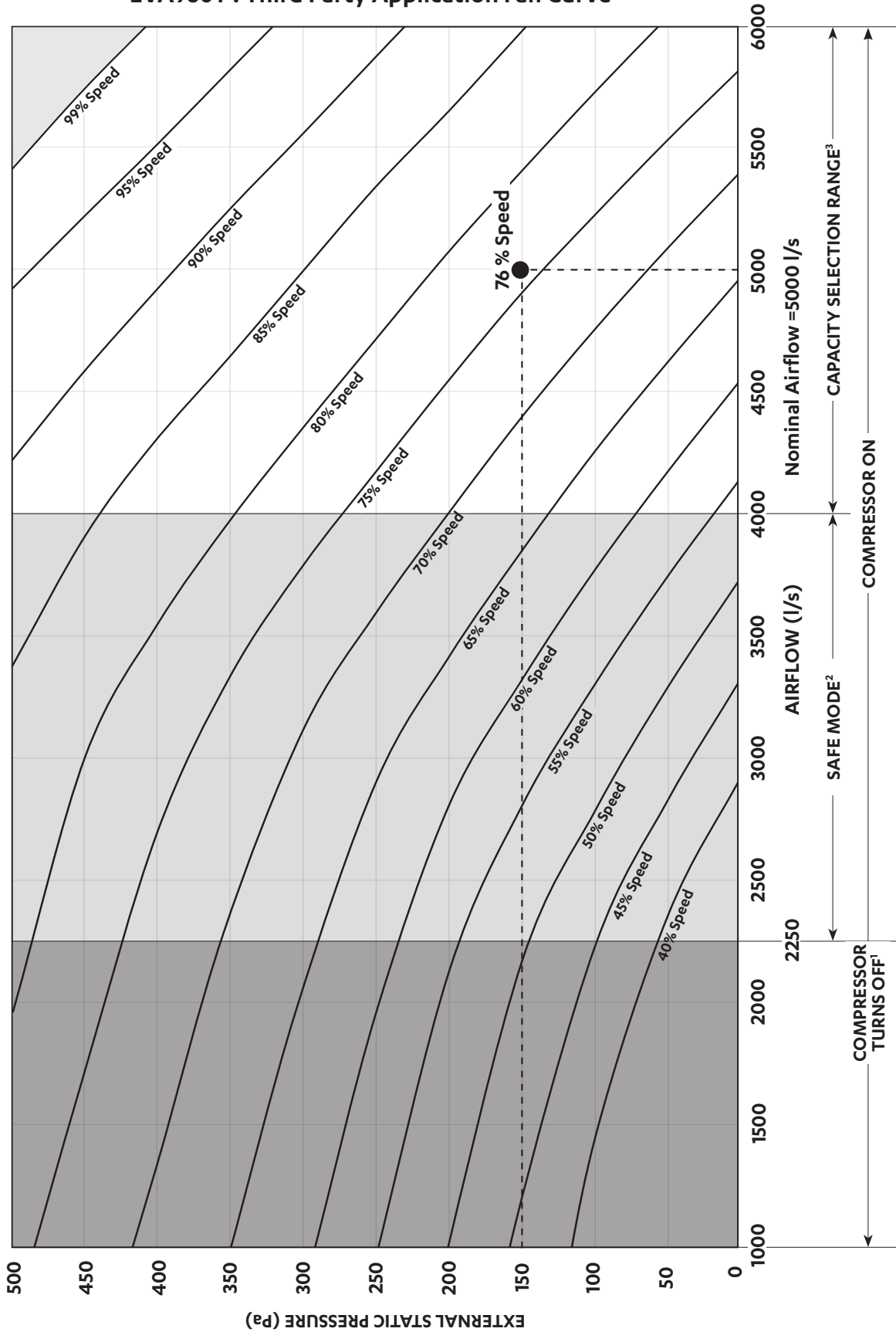

NOTE

- 1 When the airflow goes below the lower limit of the Safe Mode, the compressor turns off; the fan will continue to run.
 - 2 System safety logic may be activated
- Fan Performance Data and Fan Curve shown is at dry coil and with no air filters installed. Consider external static pressure drop specific to your design requirements. Airflow should be reduced with respect to the moisture content in the air. Please review filter manufacturer for application. 2.5 m/s face velocity point will occur outside the application range.

Sensor Detail

OUTDOOR SENSORS			
Sl.No.	Description	Location	ActronAir Part Number
1	Compressor 1 Discharge Temp. Sensor	Compressor 1 Discharge line	S2060-121-DLT1
2	Compressor 2 Discharge Temp. Sensor	Compressor 2 Discharge line	S2060-121-DLT2
3	Outdoor Coil 1 Temperature Sensor	Last return bend of Coil system 1	S2060-121-COIL1
4	Outdoor Coil 2 Temperature Sensor	Last Return Bend of Coil system 2	S2060-121-COIL1
5	Ambient Air Temperature Sensor	Outdoor Coil System 2 Air Inlet side	S2060-121-AMB
6	Suction Sensors Stage 1	Suction Line 1	S2060-121-SCT1
7	Suction Sensors Stage 2	Suction Line 2	S2060-121-SCT2
8	HP Pressure Sensor	Compressor 1 Discharge line	2060-126
9	HP Pressure Sensor	Compressor 2 Discharge line	2060-126
10	LP Pressure Sensor	Suction Line 1	2060-125
11	LP Pressure Sensor	Suction Line 2	2060-125

INDOOR SENSORS			
Sl.No.	Description	Location	ActronAir Part Number
1	Indoor Coil Temperature Sensor	Indoor Coil	2060-017

SWITCHES				
Sl.No.	Description	Location	Type	ActronAir Part Number
1	Compressor 1 High Pressure Switch	Compressor 1 Discharge Line	Pressure Switch	2060-019
2	Compressor 2 High Pressure Switch	Compressor 2 Discharge Line	Pressure Switch	2060-019
3	Compressor 1 Low Pressure Switch	Compressor 1 Suction Line	Pressure Switch	2060-123
4	Compressor 2 Low Pressure Switch	Compressor 2 Suction Line	Pressure Switch	2060-123

Refrigerant Charging

- The unit is supplied with factory-charged R-410A refrigerant as stated in the Rating Label. The use of other materials as a refrigerant may cause explosions and/or personal injury.
- Be aware of all the relevant regulations concerning the handling of refrigerant.
- The system of this unit operates with Polyester (POE)* oil.
- It is important to work with absolute cleanliness.
- Brazing must be done with the use of Nitrogen to avoid carbon deposits into the pipes.
- The system must be evacuated thoroughly to 500 microns (see evacuation procedure).
- Never allow refrigerant to vent into the atmosphere. It is an offence to release refrigerant in Australia.
- Always reclaim refrigerant using equipment and container dedicated for the refrigerant used in the system.
- Only qualified technicians are allowed to perform any work described in this guide.
- All work must be carried out in accordance with Australia and New Zealand refrigerant handling code of practice.
- Where crankcase heaters are in operation, ensure to power up the unit for a minimum of 3 hours prior to starting the compressor. For colder climates, a longer time period may be required.
- R-410A refrigerant must always be charged in liquid state. Always charge refrigerant in the unit liquid line. The air conditioning system should always be liquid charged from the cylinder. When the system is in a vacuum, always charge into the high pressure side. Although it is acceptable to charge refrigerant into the discharge service port, but the liquid line service port on the shut-off valve is recommended.
- Only during the compressor running condition can the system be charged through the suction service port on the compressor suction line.
- When the system is operating in cooling mode, it can be charged through the service port on the suction line ball valve (larger of the two shut off valves). This ensures the liquid refrigerant goes into the accumulator and then slowly enters the compressor.
- Remember, the pressure in this shut-off valve port will be high during heating mode, so the above method is not possible. The system can be charged through the suction service port on the compressor suction line. But be careful not to charge too much refrigerant at once, let the liquid enter in short bursts by opening and closing your gauges.
- Changes in refrigerant charge must be noted on a label that is fixed to the unit for future reference.

CAUTION

R-410A refrigerant has POE oil that rapidly absorbs moisture. The maximum time any system can be opened to atmosphere is 15 minutes.

Charging Method: Subcooling and Superheat

Parameters:

LLT = Liquid Line Temperature

SLT = Suction Line Temperature

SCT = Saturated Condensing Temperature

SST = Saturated Suction Temperature

Cooling and Heating Operation:

Adjust the refrigerant charge to obtain the correct super heat and sub-cool for optimal performance as follows:

1. Ensure that air filters are fitted and total system airflows are achieved. (Air filters are not supplied with the unit, it is the responsibility of the installing contractor to provide and fit adequate return air and fresh air filters).
2. Connect service gauges to the shut off valves.
3. Start the unit in cool mode ensuring that the compressor is in operation before taking service gauges reading. Allow the system to stabilise for the next 15 - 30 minutes before recording.
4. Record the discharge pressure, suction pressure, liquid line temperature and suction line temperature for all the refrigeration circuits.

Circuit 1

Discharge Pressure = _____ kPa

Suction Pressure = _____ kPa

Liquid Line Temperature (LLT) = _____ °C

Suction Line Temperature (SLT) = _____ °C

Circuit 2

Discharge Pressure = _____ kPa

Suction Pressure = _____ kPa

Liquid Line Temperature (LLT) = _____ °C

Suction Line Temperature (SLT) = _____ °C

See Diagram Below

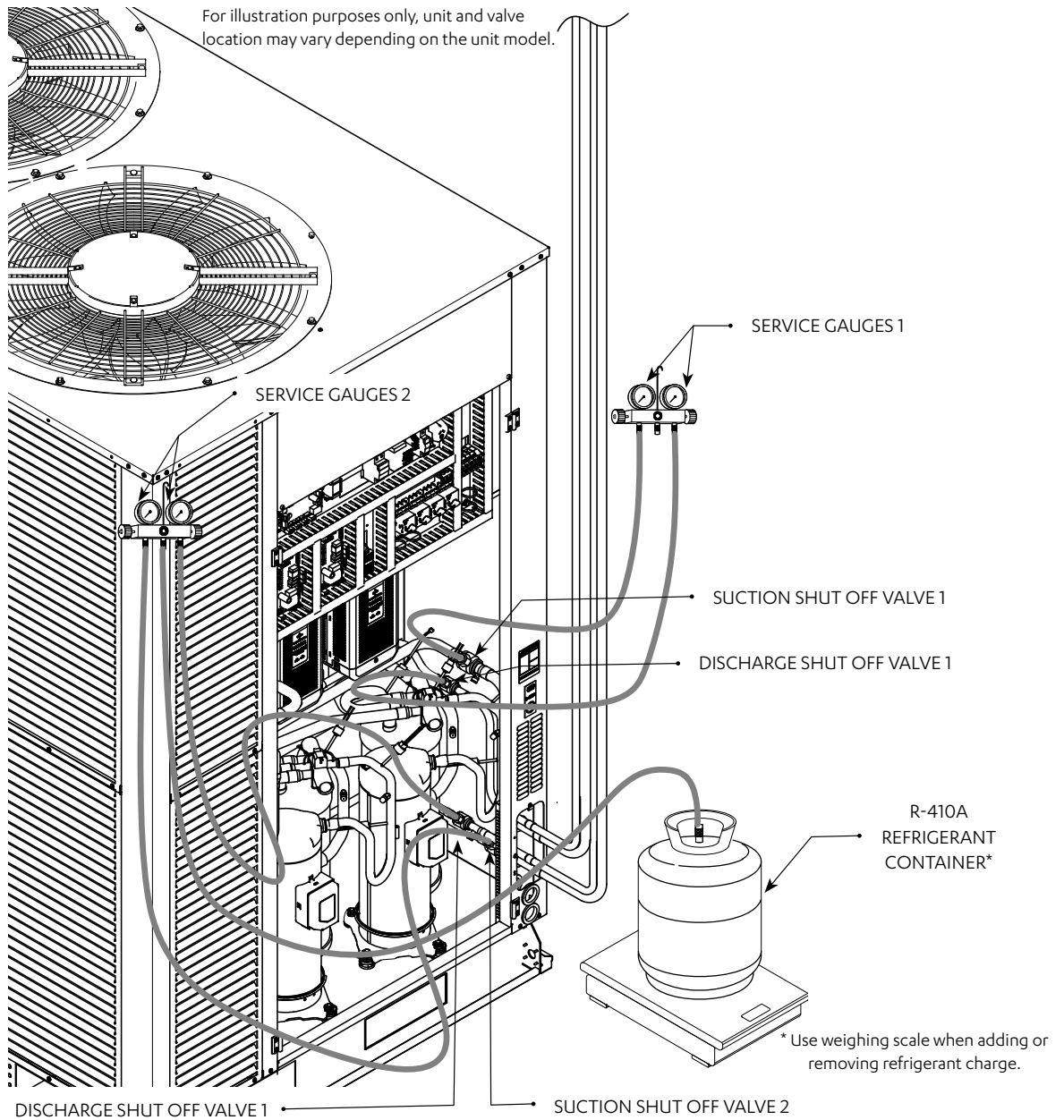

NOTES

- Accurate pressure and temperature measuring tools should be used to achieve satisfactory results.
- The sensors of thermocouple must be in good contact with the area being measured and must be insulated in order to obtain correct reading.

Checking for Subcooling

1. From the Pressure / Temperature Chart, record the corresponding Saturated Condensing Temperature (**SCT**) at the given discharge pressure.
2. Calculate the system subcooling using the formula below:

$$\text{Subcooling} = \text{SCT} - \text{LLT}$$

3. If subcooling is within the range (see charging table), there is no need to add/remove refrigerant.
 - If subcooling is lower than minimum, the system is undercharged, it is necessary to add refrigerant.
 - If subcooling is higher than maximum, the system is overcharged, it is necessary to remove refrigerant.

Allow the systems to stabilise (15 - 30 mins) and repeat the steps 1-3 until subcooling falls within the range specified in the Subcooling/Superheat Table below.

Checking for Superheat

Maintaining the correct superheat is important for ensuring the evaporator is achieving maximum capacity and avoiding excessive liquid refrigerant returning to the compressor.

1. From the Pressure/Temperature Chart, record the corresponding Saturated Suction Temperature (**SST**) at the given suction pressure.
2. Calculate the system super heat using the formula below:

$$\text{Superheat} = \text{SLT} - \text{SST}$$

3. If superheat is within the range (see charging table), there is no need to add/remove refrigerant.
 - If superheat is lower than minimum, it means that liquid refrigerant may be returning to the compressor. It is necessary to remove refrigerant or check EEV settings.
 - If superheat is higher than maximum, it means that refrigeration capability of the evaporator is not fully maximised. It is necessary to add refrigerant charge or check EEV settings.

Allow the systems to stabilise (15 - 30 mins) and repeat the steps 1-3 until superheat falls within the range specified in the table below.

Subcooling/Superheat Table			
Cooling		Heating	
Subcooling	Superheat	Subcooling	Superheat
4 - 8	2 - 8	10 - 14	2 - 8

NOTES

The above subcooling and superheat recommendations are based on the following rated conditions:

- Cooling: 35°C DB outdoor, air entering indoor at 27°C DB / 19°C WB.
- Heating: 7°C DB / 6°C WB outdoor, air entering indoor at 20°C DB Nominal indoor airflow.

CHARGING TABLE

Temp °C	Pressure KPa	Temp °C	Pressure KPa	Temp °C	Pressure KPa	Temp °C	Pressure KPa
-50	9	-19	320	11	1040	41	2439
-49	15	-18	336	12	1073	42	2500
-48	20	-17	353	13	1108	43	2564
-47	27	-16	369	14	1143	44	2628
-46	33	-15	387	15	1180	45	2694
-45	40	-14	405	16	1217	46	2760
-44	46	-13	424	17	1255	47	2829
-43	54	-12	442	18	1293	48	2898
-42	61	-11	462	19	1333	49	2969
-41	69	-10	481	20	1373	50	3040
-40	76	-9	502	21	1415	51	3114
-39	85	-8	523	22	1457	52	3187
-38	93	-7	545	23	1501	53	3264
-37	102	-6	567	24	1544	54	3340
-36	111	-5	590	25	1589	55	3419
-35	121	-4	613	26	1634	56	3498
-34	130	-3	637	27	1681	57	3580
-33	140	-2	661	28	1728	58	3662
-32	150	-1	687	29	1777	59	3747
-31	161	0	712	30	1826	60	3832
-30	172	1	739	31	1877	61	3920
-29	184	2	765	32	1928	62	4008
-28	195	3	793	33	1981	63	4099
-27	208	4	821	34	2034	64	4190
-26	220	5	851	35	2089	65	4284
-25	234	6	880	36	2144	66	4378
-24	247	7	911	37	2201	67	4476
-23	261	8	941	38	2258	68	4573
-22	275	9	974	39	2318	69	4675
-21	290	10	1006	40	2377	70	4776
-20	304						

Fault Display Codes

Outdoor Board Fault Display Codes

Display Code	Function / Fault
oFF	Unit Off or Unit Turning Off (flashing)
CoOL	Unit Cooling Mode or Start Cooling (flashing)
HEAt	Unit Heating Mode or Start Heating (flashing)
dEF3	3 min to Defrost
dEF2	2 min to Defrost
dEF1	1 min to Defrost
dEF	Heating Mode - Defrost
HEAt	Heating Mode - Indoor coil pre-heat after defrost
oiLr	Oil Return Operation
dr-1	Demand Response Management 1 - Mode (Compressor Off)
dr-2	Demand Response Management 2 - Mode (System operation restricted to 50% of rated power)
dr-3	Demand Response Management 3 - Mode (System operation restricted to 75% of rated power)
ohP	Unit derating - Overheat Protection Mode
dtP	Unit derating - Discharge Temperature Protection Mode
cPP	Unit derating - Condenser Pressure Protection Mode
hSP	Unit derating - High Suction Pressure Protection Mode

ADC: Analog to Digital Converter
 IGBT: Insulated-Gate Bipolar Transistor

DSP: Digital Signal Processor
 PFC: Power Factor Correction

Reading the error code

Digit 1	Digit 2	Digit 3 + 4
Source	Circuit #	Error code

For Example:

Digit 1	Digit 2	Digit 3 + 4	Error code	Error Description
A	1	06	A106	Discharge temperature high

Digit 1	Digit 2	Digit 3 + 4	Error Description
A = Outdoor unit	*1 = Circuit-1 **2 = Circuit-2	06	Discharge temperature high
		07	Coil sensor failure
		08	Discharge sensor fail
		09	LP switch open
		10	LP sensor fail
		11	HP switch open
		12	HP sensor fail
		13	VSD fault
		18	Suction temperature sensor fail
		22	Ambient Sensor Fail
		50	Configuration error
B = Indoor unit	1* / 2**	01	Phase failure (3-phase devices) or line undervoltage (single-phase devices)
		03	Output stage overheated
		04	Modbus Communication Error
		05	Fan Error
C = Compressor Envelope	1* / 2**	01	Outside envelope, area A
		02	Outside envelope, area B
		03	Outside envelope, area C
		04	Outside envelope, area D
		10	OHP Trip

Digit 1	Digit 2	Digit 3 + 4	Error Description
d = Drive	1* / 2**	01	Compressor Phase Overcurrent
		02	AC Input Overcurrent
		03	DC bus overvoltage
		04	DC bus undervoltage
		05	AC input overvoltage
		06	AC input undervoltage
		07	AC voltage imbalance
		08	Inverter desaturation
		09	HP Switch open
		12	Power module over temperature
		13	PFC igbt over temperature
		14	Lost rotor position
		15	Motor thermistor fault
		16	Precharge relay open
		17	DC voltage low
		18	Compressor phase over current intermediate
		19	Compressor phase current foldback
		20	Power module temperature foldback timeout
		21	AC input current foldback timeout
		23	Modbus communication lost
		24	Auto config communication fail
		25	DLT over temperature
		26	Motor temperature high
		27	Board temperature high
		28	Power module temperature high
		29	PFC IGBT temperature high
		30	DSP PFC Communication lost
		31	DSP communication lost
		32	Compressor phase current imbalance
		33	Three phase PFC current imbalance
		34	Micro electronics fault
		35	Motor overspeed
		37	HP transducer fault
		38	Compressor model config error
39	HP Sensor type config error		
49	PFC temperature imbalance		
50	DLT low temperature		
51	Motor temperature low		
52	Power module temperature low		
53	PFC IGBT temperature low		
54	Communication ADC failure		
62	Fault limit lockout		
E = Outdoor fan F = Indoor fan	1* / 2**	01	Phase failure (3-phase devices) or line undervoltage (single-phase devices)
		03	Output stage overheated
		04	Modbus Communication Error
		05	Fan Error
		06	Motor overheated
		07	Hall sensor error
		08	Motor blocked
		09	Speed limit exceeded
11	Rotor position sensor calibration error		
		13	DC-link undervoltage

Digit 1	Digit 2	Digit 3 + 4	Error Description
H Communication	1* / 2**	15	VSD Communication
		51	IDU Communication
		52	WC Communication
		54	IDU Fan Communication
		55	ODU Communication
		56	Master WC Communication
		57	ODU Fan Communication

Maintenance

Maintenance Procedures

This section describes the procedures that must be performed as a part of normal maintenance program. Regular servicing of equipment by licensed technician is highly recommended. Regular servicing of your unit helps in maintaining its optimum performance and reliability. **The checklist and service periods provided on this manual are guides only, as some sites may require more frequent servicing.** Always disconnect electrical power to the unit before performing these procedures unless otherwise required. It is always a safe practice to observe all safety warnings and cautions when conducting maintenance tasks.



DANGER

Live Electrical Connections!

It may be necessary to work with live electrical components on certain maintenance tasks. Only licensed electricians and qualified technicians are allowed to perform these tasks.

Beware of Rotating Fan Blades!

Always make sure that all power supplied to the fans are turned Off and isolated.

Observe WH&S safety procedures, do not wear loose clothing and any jewellery when working near the fans.

Wear PPE whenever performing any maintenance procedures.

Observe all necessary procedures when working on a confined space.



WARNING

Hazardous Voltage!

Always make sure that all power supply, including remote controls, are disconnected before performing maintenance.

Observe proper LOCK-OUT/TAG-OUT procedures to ensure that power cannot be inadvertently energised. Failure to disconnect power before maintenance procedures can result in serious injury and/or death.

EC Motors are fitted with high power capacitors and can have dangerous residual voltages at motor terminals after power has been isolated. Wait at least 5 minutes after power isolation and test for any residual voltage before beginning service work.

Annual Maintenance Checklists

- Perform general maintenance inspections.
- Perform scheduled start-up checks.
- Leak test refrigerant circuits.
- Inspect contacts of all contactors and relays. Replace all worn contacts as required.
- Inspect, clean and tighten all electrical connections.
- Check fans for balanced operation. Make sure that there are no loose screws / bolts, no fan blades interference and no damage to the fans and guards.
- Inspect the air filters, clean or replace as required.
- Clean and repaint any corroded panel section.
- Ensure no blockage of airflow through variable speed drive.

Cleaning the Condenser Coils

Clean the coils at least once a year or more frequently if unit is located in a dusty and dirty environment, in order to maintain your system's proper operating performance. High discharge pressures are good indication that the coils need cleaning. When using detergent or solvents to clean the coils, follow the manufacturer's instructions to avoid potential damage to the coils and to the unit.

To clean the refrigerant coils, use a soft brush and water spray, such as garden hose or pressure washer with low pressure nozzle.

 **WARNING****Do Not Use High Alkaline Detergent!**

When using detergent for coil cleaning, ensure that the alkaline level is no higher than 8.5, which can cause corrosion damage to the coils.

 **DANGER****No Water into the Electrical Compartments!**

Ensure consideration is given to the possibility of water entering the electrical compartments during cleaning of the condenser coil.

Coil Cleaning Procedures

- Disconnect power to the unit.
- Remove the louvered panels from the unit to gain access to the air inlet side of the coils.
- Use a soft brush to remove loose dirt and debris from both sides of the coils.
- Straighten bent coil fins with fin comb.
- Prepare the detergent solutions according to the manufacturer's instructions.
- Spray solution at a 90° angle to the coils, keeping a minimum nozzle spray angle of 15°, with at least a 1800mm distance from the coils and 600 psi pressure.
- Spray leaving air side of the coils first then the air inlet side. Allow the solution to stand on the coils for five minutes.
- Rinse both sides of the coils with cool clean water.
- Inspect the coils, if they are still dirty, repeat the cleaning procedure.
- Clean and wipe dry the outer and inner sides of the unit, the refrigerating parts and other components.
- Ensure that the condensate drain lines are not blocked.
- Reinstall all unit panels, covers and guards.
- Restore electrical power to the unit.

Maintenance Frequency Checklist

Regular servicing of equipment by a qualified technician is recommended every 12 months for residential applications and every quarter for commercial applications. Regular servicing of your unit helps in maintaining its optimum performance and reliability. **The following checklist and service periods are provided as a guide only, as some sites may require more frequent servicing.**

ELECTRICAL											
Parts	Service Period								Detail of Service Check	Service Methods	
	1 Mth	3 Mth	6 Mth	1 Yr	2 Yrs	3 Yrs	4 Yrs	5 Yrs			
Printed Circuit Boards				✓						Visual Inspection	Tighten Terminals as necessary on printed circuit boards
Electrical Connections				✓						Check all electrical terminals, mains, communications, etc	Re-tighten if loose.

OUTDOOR UNIT											
Parts	Service Period								Detail of Service Check	Service Methods	
	1 Mth	3 Mth	6 Mth	1 Yr	2 Yrs	3 Yrs	4 Yrs	5 Yrs			
Casing / Panels and Frames				✓						Visual check for damage, rust and dust accumulation.	For highly corrosive environment, wash panels quarterly with water and neutral detergent solution. Wax panels. Repair / re-paint where required.
Insulation				✓						Visual check for insulation conditions.	Repair / replace insulation material.
Fan				✓						Visual check for run out of balance and dust attached	Clean off dust as necessary to negate possibility of fan running out of balance
Motor				✓ Ω						Visual check on wiring. Insulation resistance check to be carried out annually	Measure insulation resistance. Should be more than 1MΩ
Heat Exchanger				✓						Check for clogging by dust. Check for leaks / damage.	Clean air inlet side as necessary. Straighten any bent fins using fins comb.
Condensate Drain Line (if available)				✓						Check for obstructions and free flow of water	Clean to eliminate obstructions/sludge and check condition of drain line. Pour water to ensure free flow.
Compressor				✓ Ω						Check for high / low pressure. Measure insulation resistance. Check compressor for abnormal noise/vibrations	Measure insulation resistance. Should be more than 1MΩ.
Refrigeration Operational Readings				✓						Make note of operational reading in test cool/heat	Check operating pressures, record superheat and subcooling values
Safety Devices				✓						Check calibration of safety devices such as HP and LP controls, sensors, etc	Check resistance of sensors, pressure cut in / cut out of pressure controls
Faults				✓						Check for any previous fault history on unit.	Investigate any causes for previous faults, reset fault history.

Start Up and Commissioning Report

INSTALLATION INFORMATION	
CUSTOMER	Name: _____ Tel. Number: _____
	Address: _____
INSTALLER	Name: _____ Tel. Number: _____
	Address: _____
Site Address: _____	Date Installed: _____
Model: _____	Serial Number: _____

CIRCUIT TEMPERATURE SETTINGS	
Supply Air Temperature	_____ °C
Return Air Temperature	_____ °C
Suction Temperature	_____ °C
Discharge Temperature	_____ °C
Condenser Coil Temperature	_____ °C
Ambient Temperature	_____ °C

INDOOR FAN SETTINGS		OUTDOOR FAN SETTINGS	
Indoor Fan Current	_____ Amps	Outdoor Fan Current	_____ Amps
Indoor Fan Airflow	_____ l / s		
Indoor Fan PWM	_____ %		
Set Static	_____ Pa		

Check No Active Error Codes on the Unit	Checked: <input type="checkbox"/>
---	-----------------------------------

Date Checked:	_____
---------------	-------

Version History

DOCUMENT VERSION	BOM VERSION	UPDATE HISTORY
Ver 1	-0100	Released
Ver 2	-0100	Included lower capacity models
Ver 3	-0100	Phase 2
Ver 4	-0100	Updated menu tree in the Configuring and Commissioning Setup
Ver 5	-0100	Included NEO Wall Controller Options
Ver 6	-0100	Added Safety Precautions Information, Updated Testing Pressure, the Wiring Diagrams and Replaced AS60038 with AS60335.1



©Copyright 2022 Actron Engineering Pty Limited ABN 34 002767240. ®Registered Trade Marks of Actron Engineering Pty Limited. ActronAir is constantly seeking ways to improve the design of its products. Therefore, specifications are subject to change without notice.