

AIRES SPLIT DUCTED UNIT

Outdoor

Installation and Commissioning Guide



Model Numbers

Single Phase

CRS10AS
CRS13AS
CRS15AS
CRS17AS

Three Phase

CRS13AT
CRS15AT
CRS17AT
CRS20AT
CRS23AT



CAUTION:

The system is charged with flammable refrigerant, safety checks are necessary to ensure that the risk of ignition is minimised.

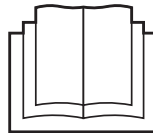

IMPORTANT NOTE:

This unit is designed for use with R-32 refrigerant only. Please read the R-32 Safety Manual and this manual carefully before installing or operating your air conditioning unit. Information in this manual is to be used in conjunction with the R-32 Safety Manual. Make sure to save this manual for future reference.

Table of Contents

Introduction	4
General Information	5
Safety Instructions	7
Installation Information	8
Operation Manual Access	9
Components Overview	10
CRS10AS	10
CRS13AS/AT	11
CRS15AS/AT and CRS17AS/AT	12
CRS20AT and CRS23AT	13
Control Panel	14
CRS10AS	14
CRS13AS/AT	15
CRS15AS/AT and 17AS/AT	16
CRS20AT and CRS23AT	17
Unit Dimensions, Clearances and Weights	18
Unit Dimensions	18
Refrigeration Pipe Distances (mm)	18
Service Clearances, Airflow Allowances and Weights	20
Unit Lifting Procedure	21
Outdoor Unit Preparation	22
Field Pipe Connection	25
Piping and Brazing	25
Pressure Testing	28
Evacuation Procedure (Triple Evacuation)	28
Electrical Installation	29
Wiring Diagram - Outdoor Units	30
Wiring Diagram - Indoor Units	36
Electrical Connection	42
Data Cable Shielding Instructions	43
Circuit Breaker Size Recommendation	44
Wall Controller Options	45
Wall Controller Options	45
Wiring Configuration : Recommended	46
Wiring Configuration : Alternate	47
Wiring Connections	48
LR7-1 and LC7-2 Wall Control Wiring Connections	48
NEO Wall Control Wiring Connections	48
LM-RS-2 Optional Sensor Wiring Connections	49
AERSS Optional Duct Sensor Wiring Connections	49

Table of Contents

Demand Response Management	50
Configuring and Commissioning Setup	51
Menu and Navigation	51
Configuring Compressor and Capacity(cnFg)	52
Configuring Control Source (CtrS)	52
Third Party Control Input (Indoor and/or Outdoor Board)	53
0-10V Analogue Input for Compressor and Indoor Fan	53
0-10V Analogue Input for Compressor with Fixed Indoor Fan Speed	54
Input for Fixed Compressor with Fixed Indoor Fan Speed	54
0-10V Analogue Input for Indoor Fan with Fixed Speed Compressor	55
Run and Fault Indication Output (Outdoor Board)	56
Remote On/Off	57
Indoor Fan Commissioning	58
EVA10AS	58
EVA13AS / EFA13AS	61
EVA15AS / EFA15AS	64
EVA17AS / EFA17AS	67
EVA20AS / EFA20AS	70
EVA23AS / EFA23AS	73
Refrigerant Charging	76
Charging Method: Subcooling and Superheat	77
Recording of Final R-32 Refrigerant Charge	78
Charging Table for R-32	79
Specifications for Refrigeration	80
Maintenance	82
Maintenance Frequency Checklist	84
Version History	85

Introduction

CONGRATULATIONS on your purchase of an ActronAir air conditioning system! This unit has been designed and engineered to provide optimum air conditioning and to achieve maximum energy efficiency.

Your air conditioning system has been manufactured from the highest quality materials. Numerous “in house” and “external” inspection and test procedures were conducted to your air conditioner to ensure satisfactory operation.

Information About This Guide

This guide provides installation instructions, specific to your ducted unit. Read this manual thoroughly and take into consideration all specifications and instructions to ensure correct installation and safe operation of your air conditioning system.

NOTE

Print a copy of this document and keep it for future reference. Ensure all technicians that work on the unit can refer to this manual at any time.

Product Inspections

Check your air conditioning unit and all items against the invoice upon receiving your shipment. Inspect the unit, components and accessories for any sign of damage. If there is any damage to the unit, contact ActronAir Customer Care Department immediately on: **1300 522 722** to obtain a Goods Return Number.

Check the unit nameplate to verify the model, serial number, electrical rated specifications are correct.

Codes, Regulations And Standards

The installer and/or contractor assumes responsibility to ensure that unit installation complies with the relevant council, state / federal codes, regulations and building code standards. All electrical wiring must be in accordance with current electrical authority regulations and all wiring connections to be as per electrical diagram provided with the unit

Important Safety Symbols And Labels

Safety Symbols and labels appear at appropriate sections throughout this manual to indicate immediate or potential hazards. Pay full attention and comply to the safety information and instructions. Failure to follow safety instructions increases the risks of personal injury, death and/or property damage. Damages to the product as a result of such failure may void warranty.

ActronAir has endeavoured to provide sufficient safety warnings and recommendations, however current and prevailing WH&S regulations must be observed and will take precedent whenever performing the installation instructions discussed in this manual.

General Information

ActronAir air conditioning units are designed for applications where superior performance, high efficiency, reliability, supply air quality and quiet operation are the prime priorities. The units are built with the latest technologies advanced variable speed driven inverter compressor, Variable speed Indoor and Outdoor Fan, low-noise outdoor fans, electronic expansion valve and an intelligent electronic control.

For optimum efficiency, your air conditioning unit will deliver just the right amount of cooling or heating capacity.

Energy Efficient Refrigeration Circuits

The ActronAir system is designed with a highly efficient refrigeration circuit that delivers only the amount of cooling or heating actually required to maintain your desired comfort at the most optimum efficiency.

Each refrigeration circuit consists of:

- High efficiency Twin Rotary compressor.
- Hydrophilic coated condenser coil designed for optimum performance and efficiency with corrugated fins and ruffled tubing
- Hydrophilic coated evaporator coil designed for optimum performance and efficiency with lanced fins and ruffled tubing
- Electronic expansion valve (EEV), to maintain efficiency at across a wide range of operating conditions

Evaporator Section

The evaporator section has EC fans which deliver just the right amount of airflow, depending on requirements. The fans provide superior performance for your comfort at optimum efficiency:

- Highly efficient EC motor that uses less energy than the traditional fixed speed induction motor
- Easy indoor fan commissioning via intelligent controllers
- Low noise operation
- Adjustable Indoor Airflow

Condenser Section

Uses DC axial fans and state of the art Inverter Compressor, with the following features:

- Efficient Twin Rotary Compressor and Inverter Drive combination
- Efficient axial fans with direct drive DC motor
- Low noise operation
- Variable compressor capacity
- Variable speed outdoor fan
- Turbo Mode for extra capacity (limited time)

Durable Design and Construction

ActronAir is an Australian manufacturer with proven high quality air conditioning products. Known for their durability and reliable performance, these products are designed and built to withstand the extreme Australian weather conditions.

The galvanized steel cabinet, with powder coated epoxy enamel finish, resists the toughest conditions.

Blue Hydrophilic coil fins provide protection to your heat exchangers and enhanced heat transfer with increased performance efficiency.

External fasteners in all Outdoor are coated carbon steel screws.

System Flexibility

The ActronAir air conditioning units are the first choice for residential and commercial applications, both for new construction or retrofitting projects.

Refrigerant Handling and Accountability

ActronAir strongly urges that all service technicians make every effort possible to eliminate and/or vigorously reduce the emission of refrigerants to the atmosphere. Everyone must act in a responsible manner to conserve refrigerants in accordance to the industry code of practice.

Sustainability and Environmentally Friendly

The air conditioning system is supplied with zero ozone depleting refrigerant, which has no phase out or replacement concern.

With cooling and heating performance capacity that are among the best in the market, the ActronAir air conditioning units provide the solution for the reduction of energy consumption, CO₂ emission, high fuel dependency and high network grid demand.

Safety Instructions

- Only licensed HVAC technicians* should install and service air conditioning equipment. Improper service or alteration by an unqualified technician could result in significant and major damage to the product or property which may render your warranty null and void. Such unqualified service could also lead to severe physical injury or death. Follow all safety instructions in this literature and all warning labels that are attached to the equipment.
- Prevailing WH&S regulations must be observed and will take precedence to the safety instructions contained on this manual. Safe work practices and environment must be the paramount importance in the performance of all the service procedures.
- Ensure that unit installation complies with relevant council regulations and building code standards.
- All electrical wiring must be in accordance with current electrical authority regulations and all wiring connections to be as per electrical diagram provided.
- Secure the fans against accidental contact. Beware of pinch point and sharp edges which can cause cutting injury.
- Always wear appropriate PPE, remove any dangling jewelery and protect long hair by wearing a cap.
- Make sure that safety guards and panel covers are always firmly secured and not damaged before and during operation of unit.
- This appliance is not intended for use by young children or infirm persons unless they have been adequately supervised by a responsible person to ensure that they can use the appliance safely. Young children should be supervised to ensure that they do not play with the appliance.
- Installer must incorporate a means of electrical disconnection (isolator) in the sub mains fixed wiring in accordance with the latest edition of the AS/NZS 3000 (also known as Australian Wiring Rules) or AS/NZS 3008.
- Secure the power cords and control cables that goes in/out the unit. Use the cable ties provided in the control box.
- This unit is designed for use with R-32 refrigerant only.

*Qualifications required will be appropriate Electrical, Refrigeration and Refrigerant Handling License and Training dependent on local State/Territory regulations.

DANGER

Hazardous Voltage - Risk of Electrocution.

TURN-OFF the power from main isolator before proceeding with any service work of the unit. Observe proper LOCK-OUT/TAG-OUT (LOTO) procedures for electrical appliances in order to prevent accidental switching-on of the power supply.

WARNING

EC Motors and Compressor Drives are fitted with high power capacitors and can have dangerous residual voltages at motor/drive terminals after power has been isolated. Wait at least 5 minutes after power isolation and test for any residual voltage before beginning service work.

CAUTION

Beware of Rotating Fans !

Ensure that indoor and outdoor fans are isolated and have come to a complete stand still before servicing the equipment. Beware of pinch point and sharp edges which can cause cutting injury. Secure the fans against accidental contact. Always wear appropriate PPE and remove any dangling jewellery and protect long hair by wearing a cap. Ensure that no loose clothing can be caught / entangled in moving parts.

VISUAL INSPECTION AND WORK ASSESSMENT

Work areas and conditions must first be assessed and evaluated for any potential hazardous conditions. It is also important to be familiar with the unit parts and components before proceeding with any service task.

Installation Information

All service technicians handling refrigerant must be licensed to handle refrigerant gases.

Recover and Recycle Refrigerants

Never release refrigerant to the atmosphere! It is an offence in Australia to do so. Always recover, recycle and reuse refrigerants. When removing from the system, properly contain and identify refrigerants in its dedicated container for proper disposal and/or storage. Always consider the recycle or reclaim requirements of the refrigerant before beginning the recovery procedures. Obtain a chemical analysis of the refrigerant if necessary. For the recovered refrigerant and acceptable refrigerant quality, refer to the existing standards and regulations.

Refrigerant Handling and Safety

Consult the refrigerant manufacturer's Material Safety Data Sheet (MSDS) for information on proper handling and to fully understand health, safety, storage and disposal requirements. Use the approved containment vessels and refer to appropriate safety standards. Comply with all applicable transportation standards when shipping refrigerant containers.

Service Equipment and Recovery Procedures

Always use refrigerant reclaiming equipment in order to minimise refrigerant emissions. Use equipment and methods which will pull the lowest possible system vacuum while recovering and condensing refrigerant. Equipment capable of pulling a vacuum of less than 500 microns is required.

Do not open the system to the atmosphere for service work until refrigerant is fully removed and/or recovered. Perform refrigeration system evacuation, prior to charging, in accordance with AIRAH / IRHACE Refrigerant handling code of practice.

Let the unit stand for 1 hour and with the vacuum not rising above 500 microns. A rise above 500 microns indicates a leak from the system and a leak test is required to locate and repair any leak.

CAUTION

A leak test is always required on any repaired section of the refrigeration system.

Charge refrigerant into the system only after the equipment does not leak or contain moisture. Take into consideration the correct amount of refrigerant charge specified for the system to ensure efficient unit operations. When charging is complete, reclaim refrigerant from charging lines into an approved refrigerant container. Seal all used refrigerant containers with approved closure devices to prevent unused refrigerant from escaping to the atmosphere. Take extra care to maintain all service equipment directly supporting refrigerant service work such as gauges, hoses, vacuum pumps and recycling equipment.

INSTALLATION PREPARATION (Pre-Installation considerations)

The following items must be considered before beginning the unit installation:

- Verify the unit capacities and ratings with the unit nameplate.
- Make certain the floor or foundation is level, solid and has sufficient structural strength to support the unit and accessories weight.
- Allow minimum recommended clearances for periodic maintenance and service access.
- Allow sufficient space for the outdoor air discharge. Condenser air inlet, located on the coil side of the unit, requires sufficient airflow clearance for the optimum unit performance.
- Note the conditioned supply air and return air location. Ensure sufficient spaces are allocated for these purposes.
- For the connection and location of condensate drain in the unit, refer to the drawings and dimensions section of this manual.
- Use anti-vibration rubber pads (supplied) on residential units (**up to 24kW split ducted**).
- If the installer is using external supplied vibration mounts
 - Install anti-vibration rubber under **all of the unit's feet** to help reduce noise and minimize vibration transfer through the foundation. Ensure that all anti-vibration rubbers are rated to provide stable support without impairing the unit's structural integrity.
 - Diameter or width of anti-vibration rubber's must be at least equal to the width of the actual feet to prevent deformation overtime.

- Wiring connections must be in accordance with the wiring diagram provided with the unit.
- Make sure all wirings are in accordance with local electricity authority regulations and standards.
- Do not install the unit close to an area where there is a danger of fire due to volatile, explosive, flammable and/or hazardous materials.
- Ensure that spaces around the unit are free from any obstructions for optimum unit performance.
- Installer to ensure correct size/type that main circuit breaker and cable is installed in unit sub-mains to protect the sub-mains and unit wiring.
- Installer to ensure correctly rated residual current device (RCD) is installed as per the latest edition of the AS/NZS 3000 (also known as Australian Wiring Rules).
- Secure the power cords and control cables that goes in/out the unit. Use the cable ties provided in the control box.

 **CAUTION**

This outdoor unit is designed to match only with an ActronAir indoor unit as specified in the Technical Selection Catalogue. The unit is supplied with factory charged refrigerant as stated in the Rating Label. The use other material as a refrigerant may cause explosion and/or personal injury.

Be aware of all the relevant regulations concerning the handling of refrigerant.

For units charged with R-32

R-32 refrigerant (CLASS A2L) is mildly flammable.

Thoroughly read and understand the accompanying R-32 Safety Guide for installation and maintenance instructions.

Installation, service, maintenance, repairs and decommissioning of this unit must be performed by a licensed HVAC technician; qualified to handle R-32 refrigerant.

Appliance shall be installed, operated and stored in a well ventilated area:

- where the room size corresponds to the room area as specific for operation.
- without continuously operating open flames (for example an operating gas appliance) and ignition sources (for example an operating electric heater).
- away from other potential continuously operating sources that known to cause ignition of R-32 refrigerant.

R-32 refrigerant is odorless if the refrigerant gas comes into contact with fire, it may emit a poisonous gas.

Operation Manual Access

Download from website

Operation manuals can be downloaded through our website shown below.

<https://actronair.com.au/manuals/>

Components Overview

NOTE

Drawing shown below is for illustration purposes only. Actual unit may vary depending on model.

CRS10AS

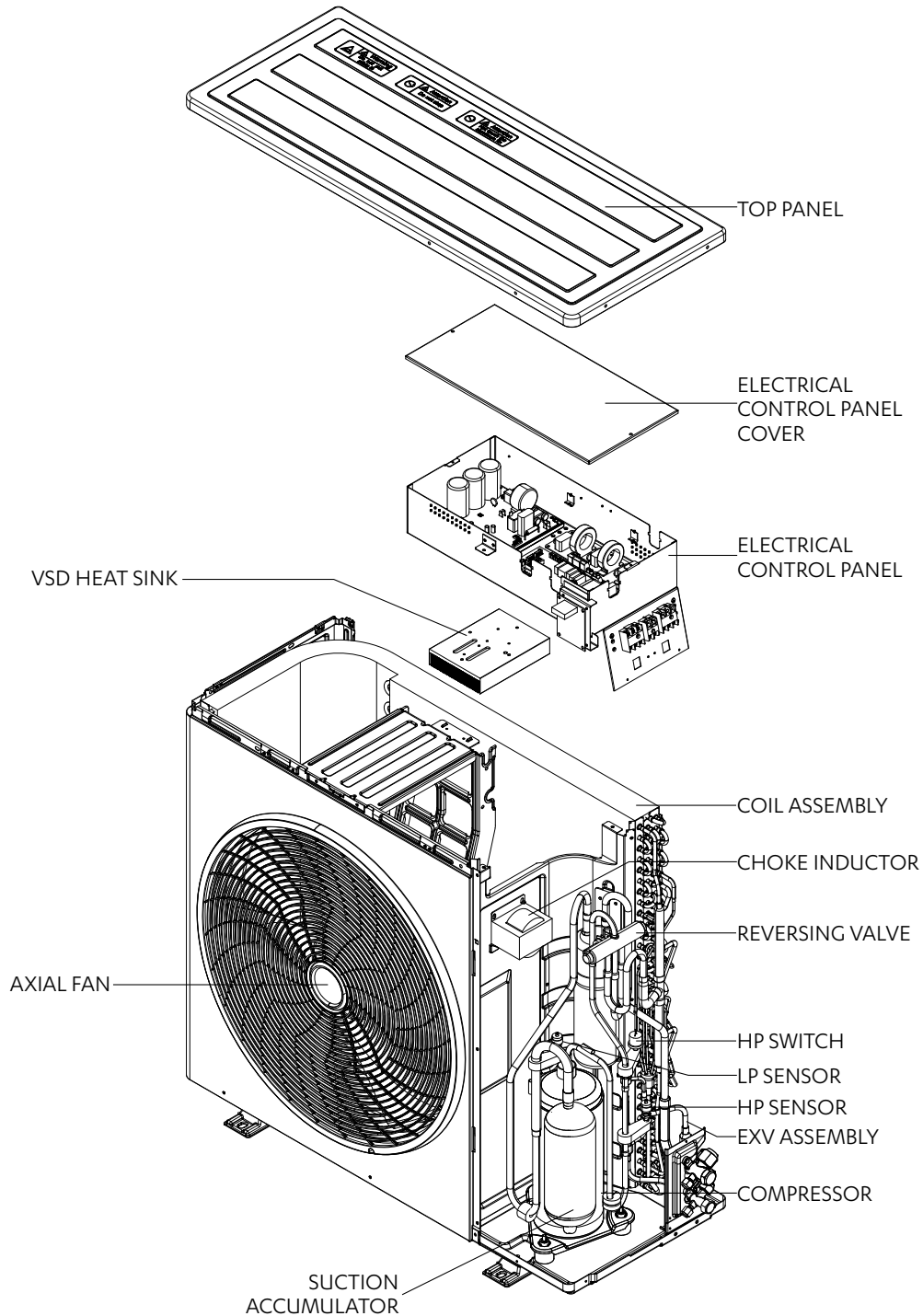

CRS13AS/AT

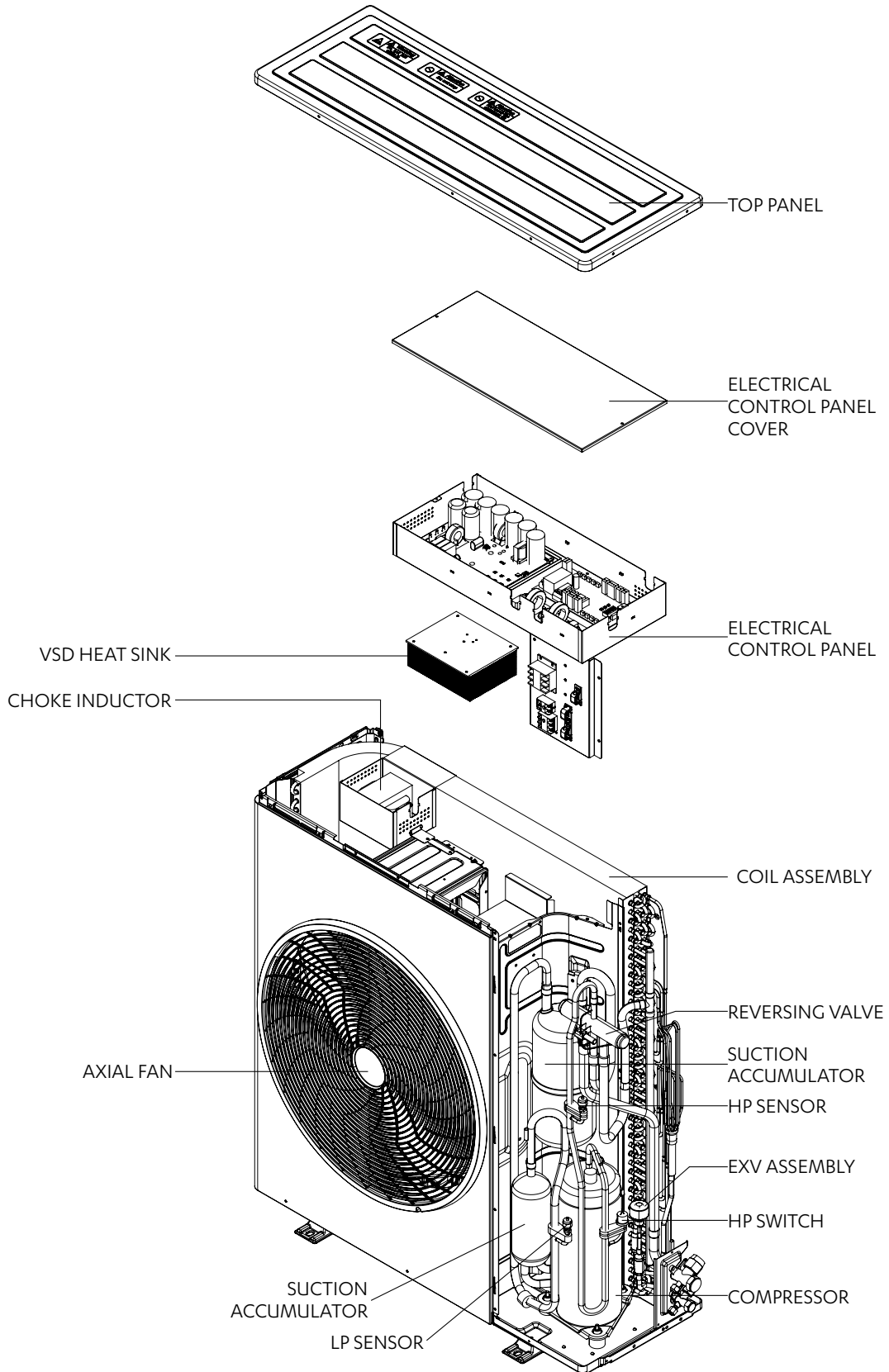

CRS15AS/AT and CRS17AS/AT

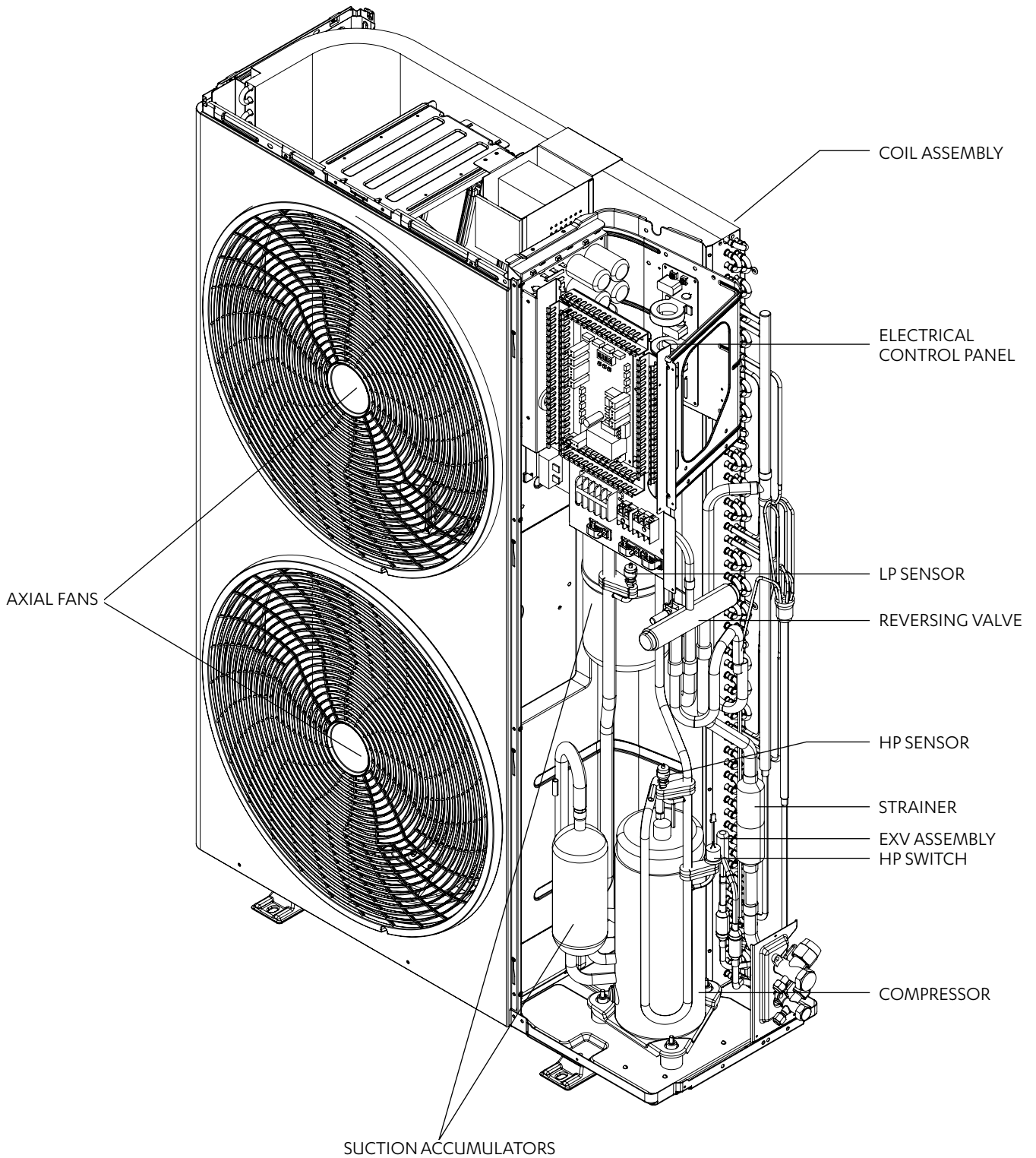

CRS20AT and CRS23AT

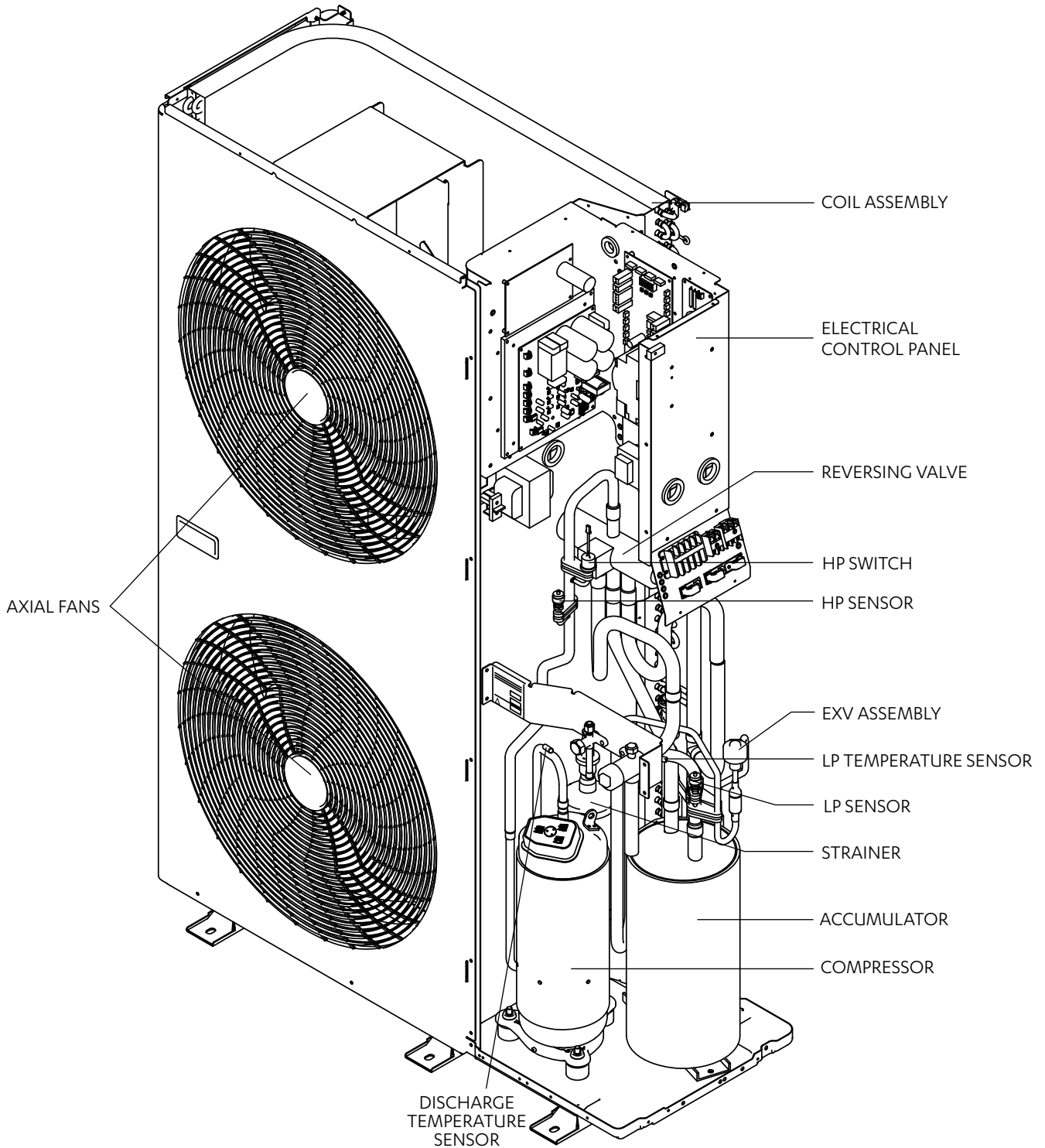

Control Panel

CRS10AS

VSD BOARD

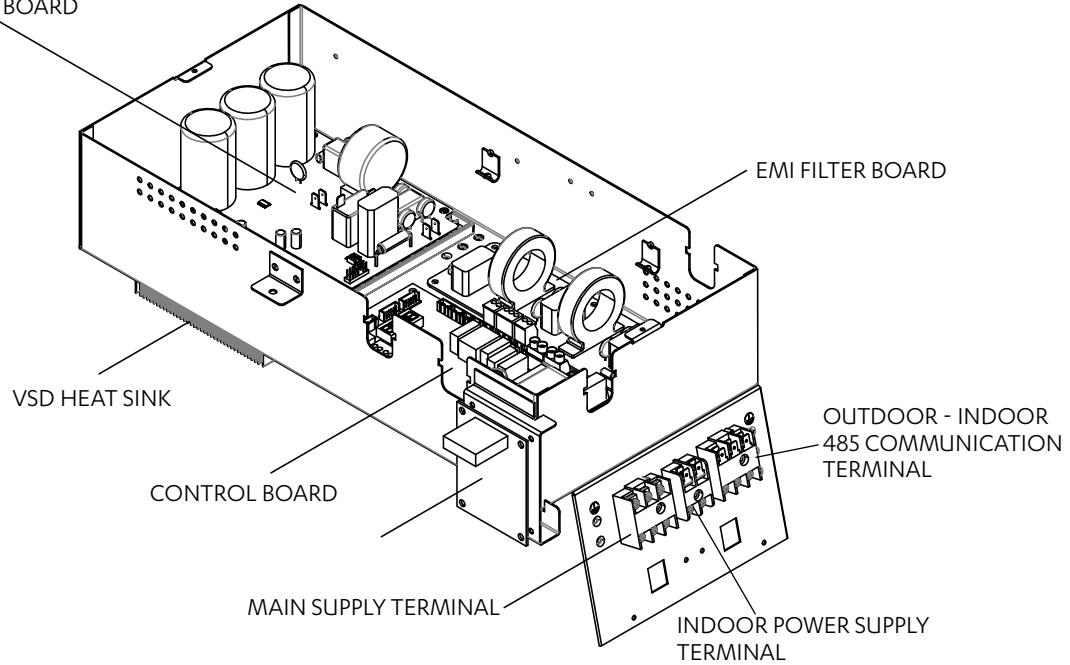

CRS13AS/AT

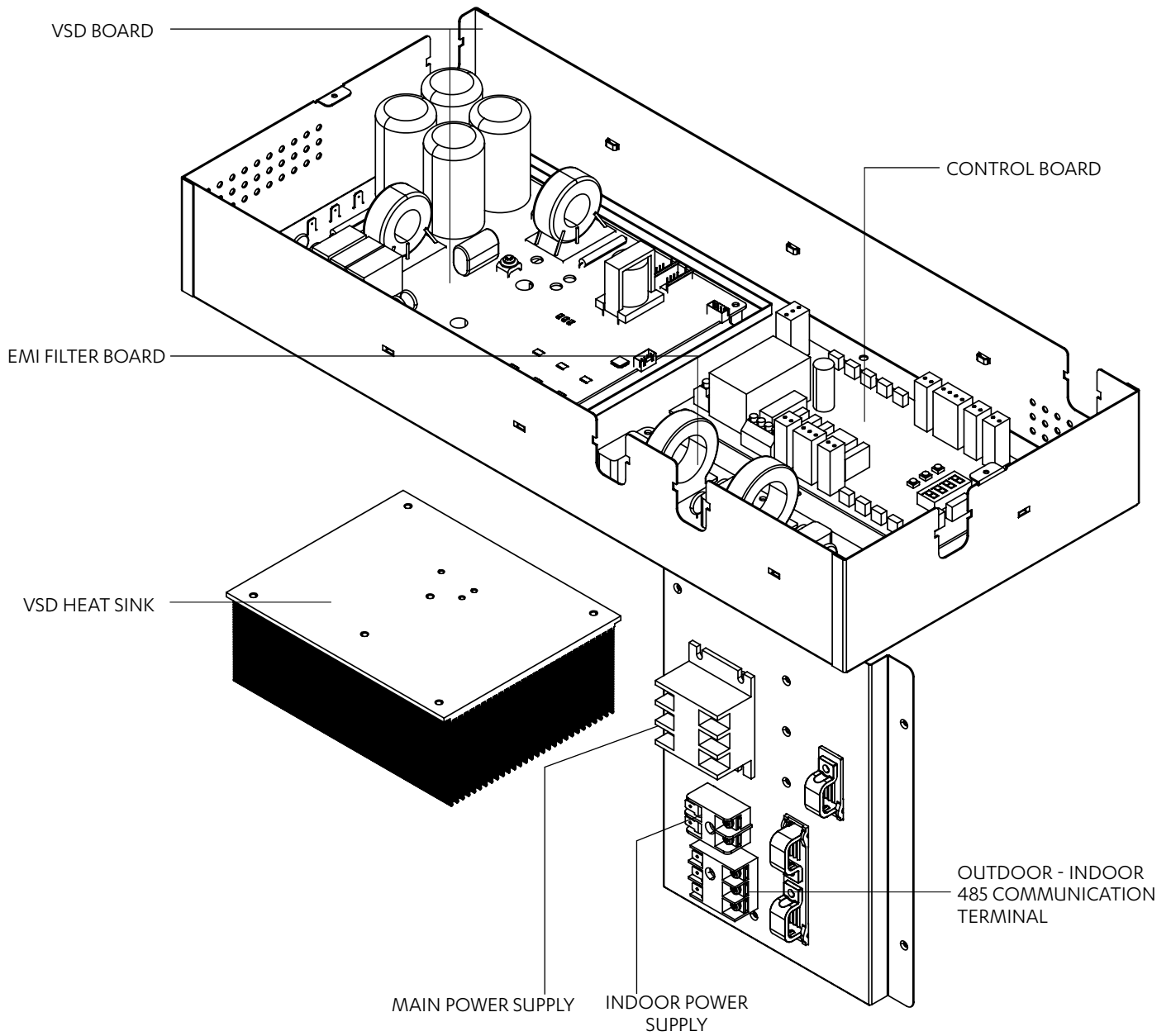

CRS15AS/AT and 17AS/AT

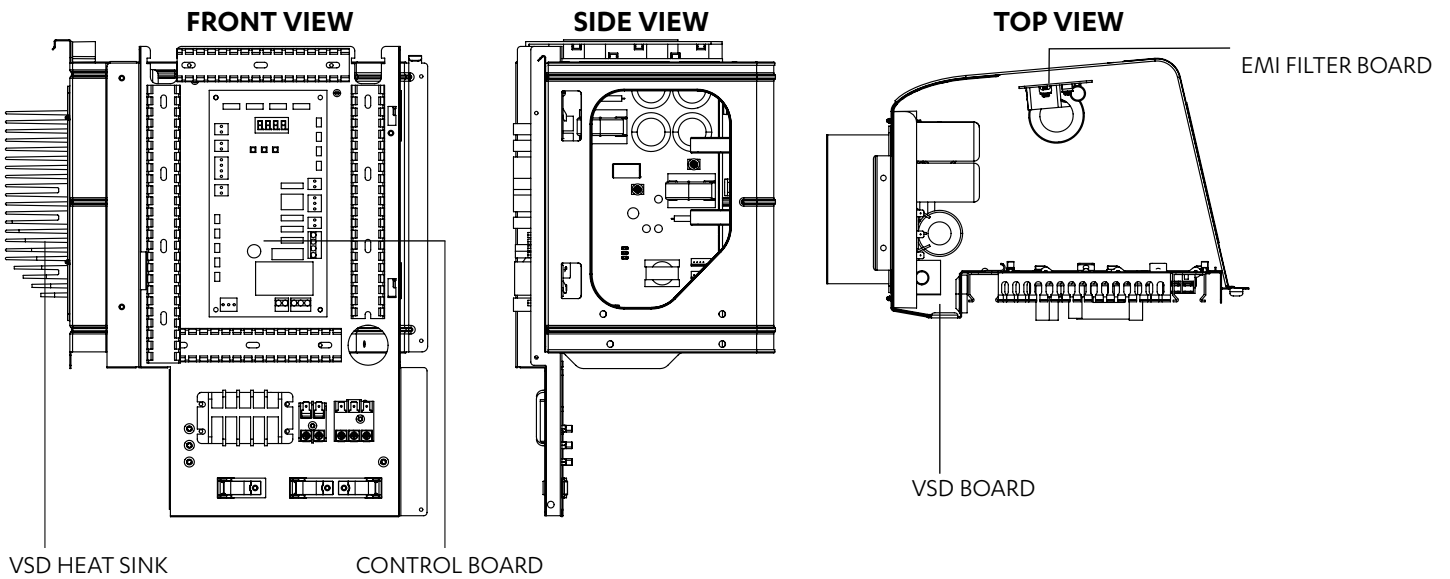
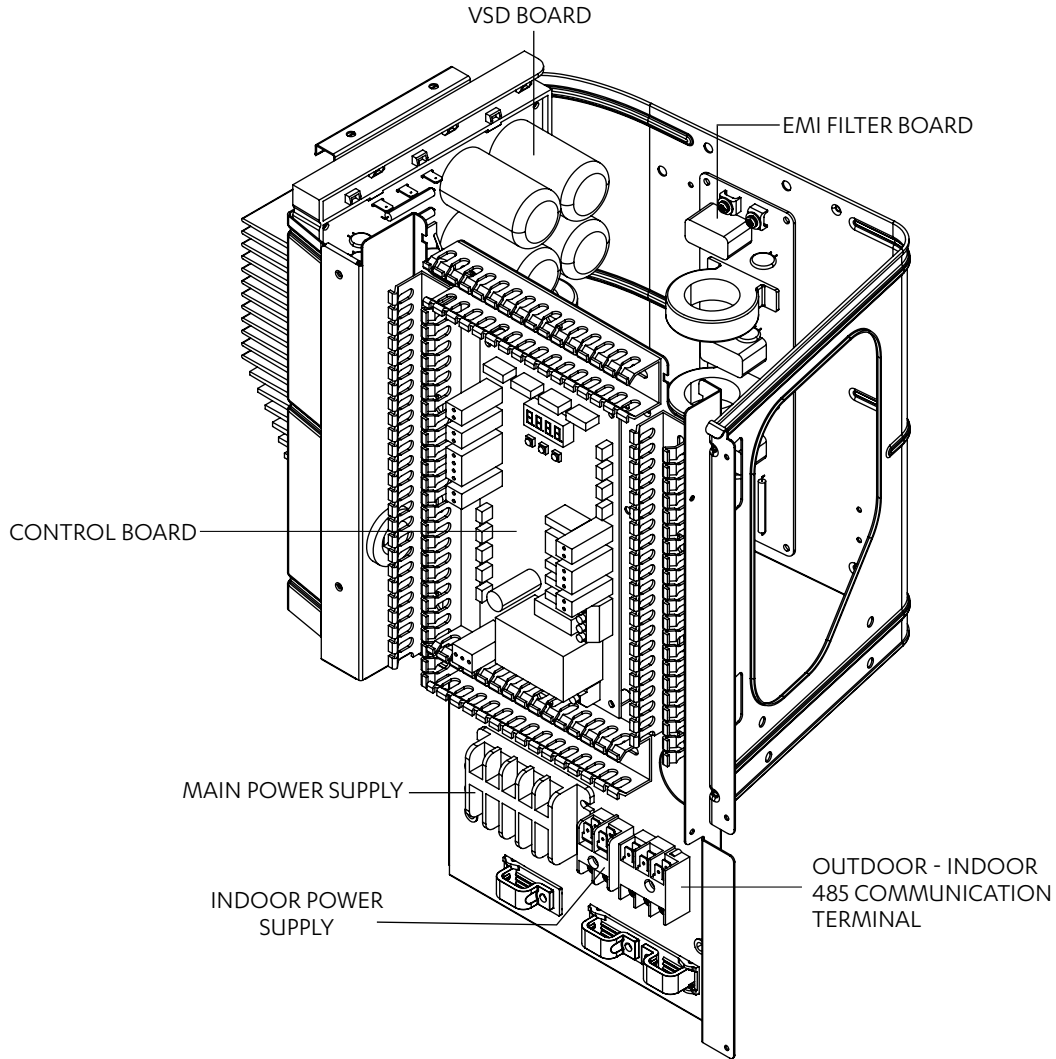

CRS20AT and CRS23AT

FRONT VIEW

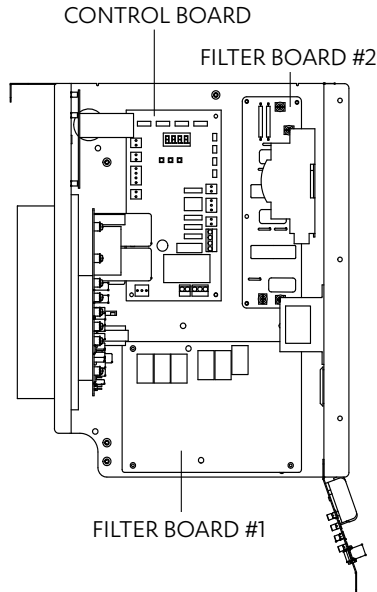

LEFT SIDE VIEW

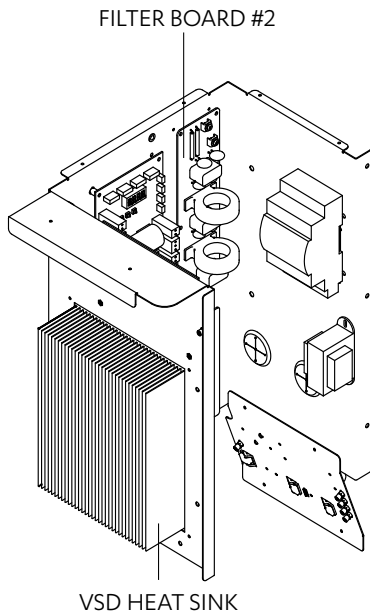

RIGHT SIDE VIEW

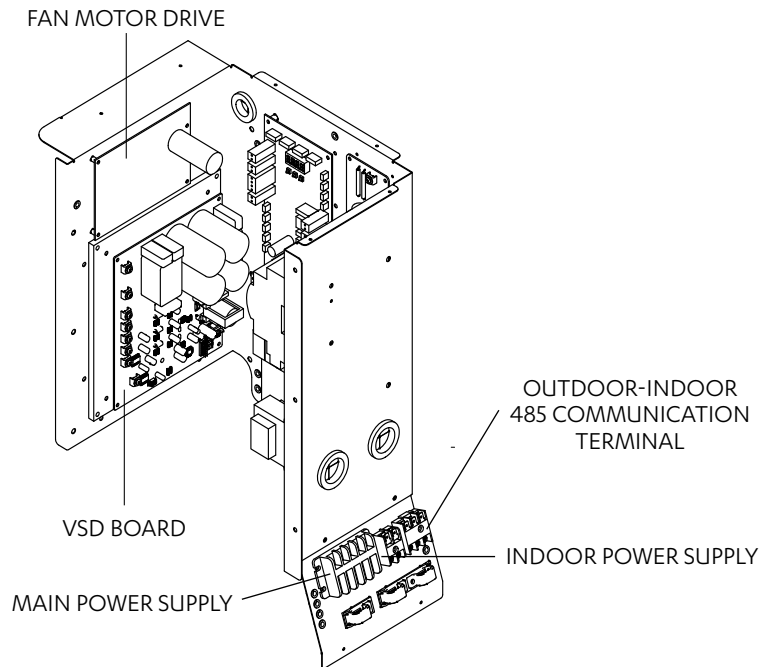

Unit Dimensions, Clearances and Weights

Unit Dimensions

NOTE:

All drawings are subject to change without notice.

CRS10AS - CRS17AS/ CRS13AT - CRS17AT

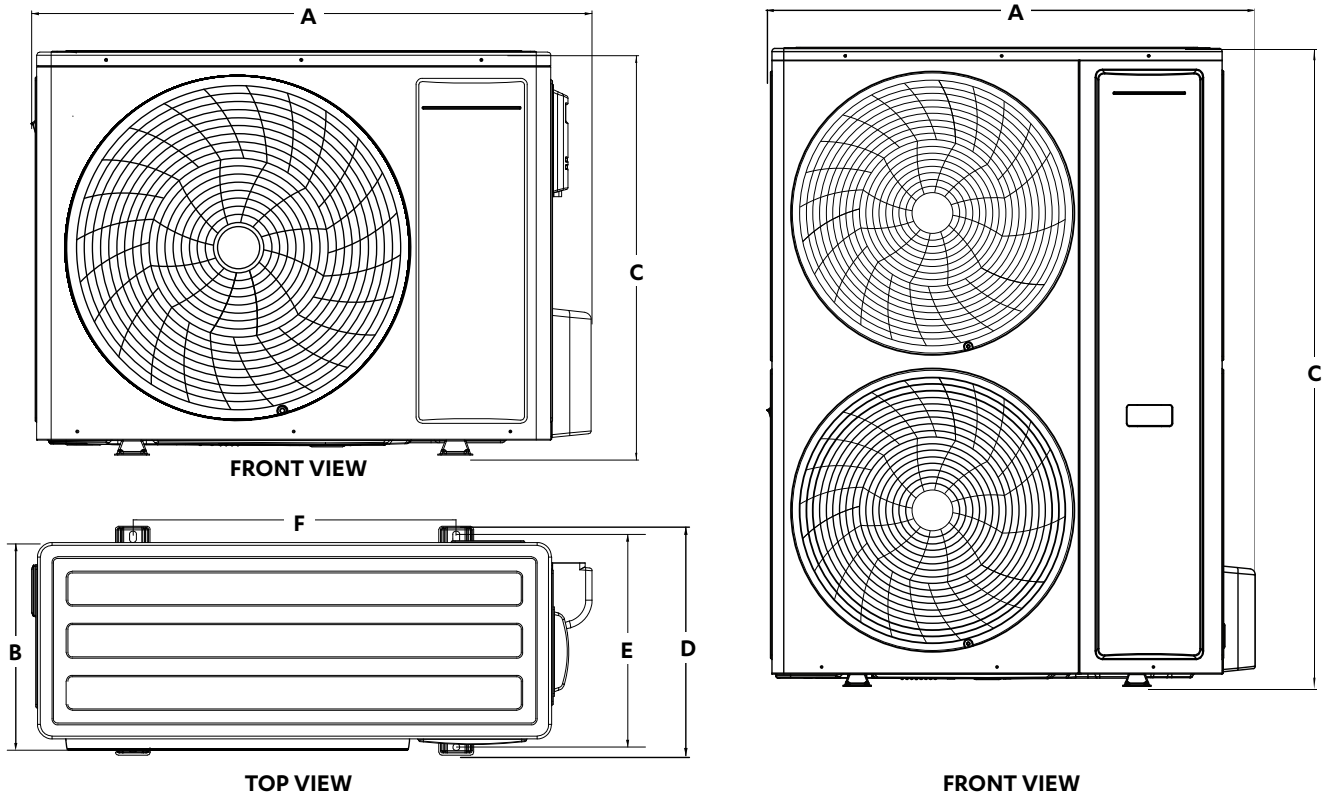

Model Number	Unit Dimensions (mm)				MTG C-C DIST (mm)*	
	A	B	C	D	E	F
CRS10AS	990	370	790	426	394	610
CRS13AS / CRS13AT	1020	340	997	396	368	590
CRS15AS / CRS15AT			1350			
CRS17AS / CRS17AT						

Note: CRS10AS / CRS13AS / CRS13AT has a single fan configuration

* MTG C-C DIST - Mounting Distance Base Foot (Centre to Centre)

Refrigeration Pipe Distances (mm)

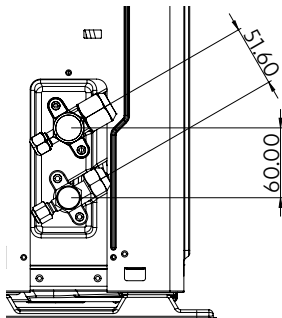

CRS20AT -CRS23AT

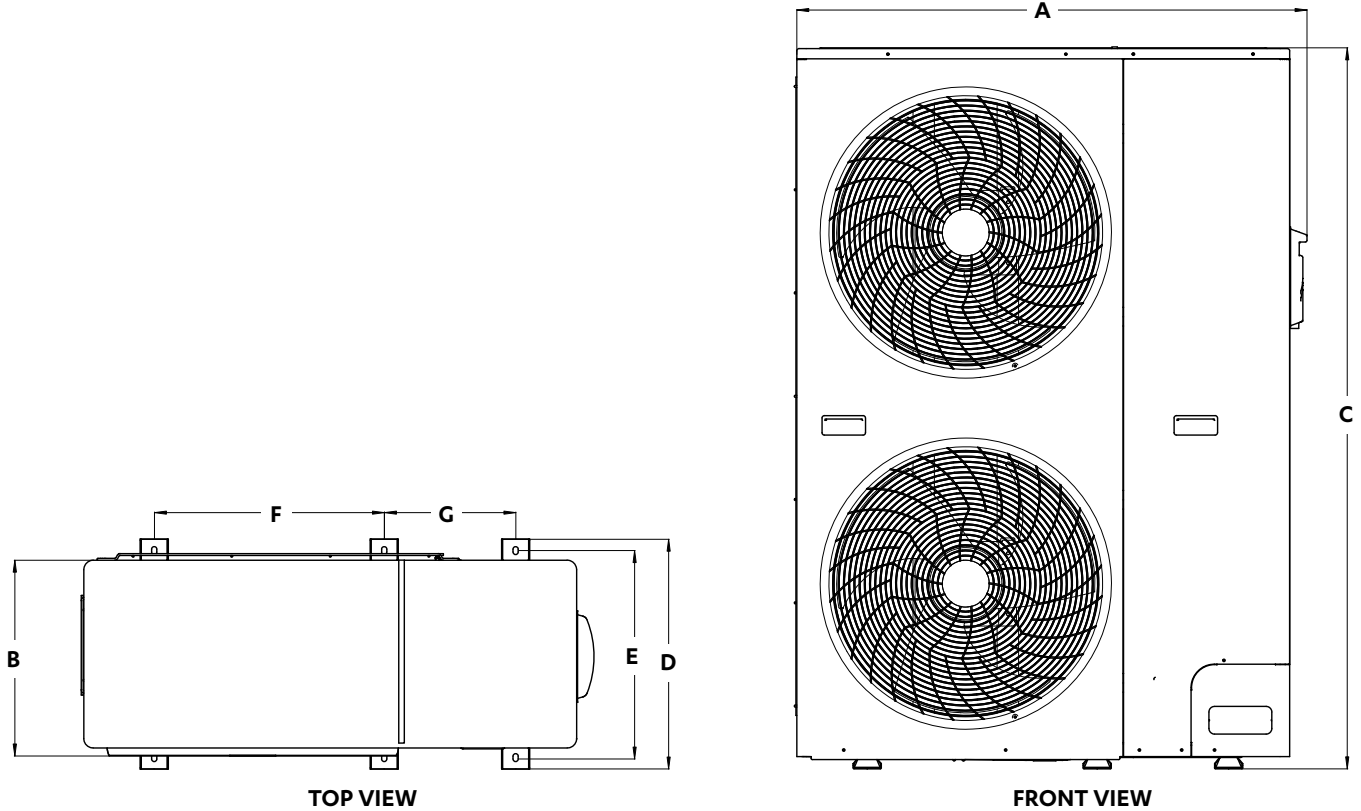

Model Number	Unit Dimensions (mm)				MTG C-C DIST (mm)*		
	A	B	C	D	E	F	G
CRS20AT	1087	417	1536	490	441	490	280
CRS23AT							

* MTG C-C DIST - Mounting Distance Base Foot (Centre to Centre)

Service Clearances, Airflow Allowances and Weights

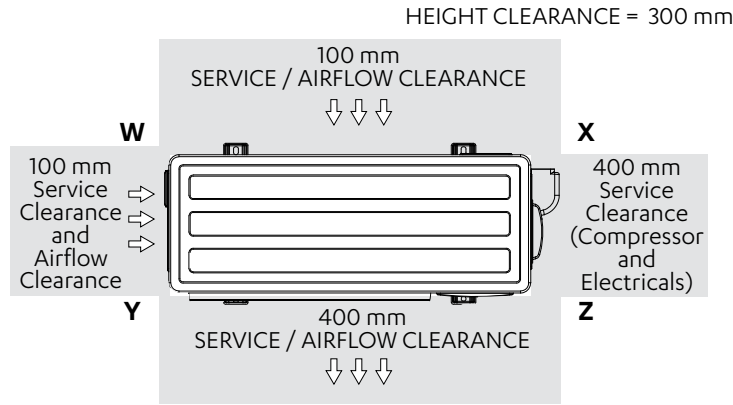

- The Service and Airflow clearances of the outdoor unit represent the minimum area recommended to ensure the designed operational performance range of the system and for safe or adequate serviceability of the system.
- The performance is influenced by the outdoor unit air intake temperatures therefore it's important to refer to the technical selection catalogue data to gain a full understanding of the effects that could lead to substandard performance if neglected.

Model Number	Net Weight	Gross Weight
CRS10AS	64	69
CRS13AS / CRS13AT	85	95
CRS15AS / CRS15AT	99	109
CRS17AS / CRS17AT	110	120
CRS20AT	142	159
CRS23AT	149	165

NOTES:

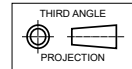

- Do not scale drawing. All dimensions are in **mm** unless otherwise specified. Refer to corresponding unit dimensional drawing for mounting hole details.
- Service Access Areas and Spaces for Airflow Clearances are suggested minimum based on the condition that the spaces around the units are free from any obstructions and a walkway passage of 1000 mm between the units or between the unit and the outside perimeter is available.
- Minimum service access areas and spaces for airflow clearances are responsibilities of the installer, ActronAir will not be held liable for any extra charges incurred due to lack of access and space for airflow.
- Under all circumstances, condenser air must not recirculate back onto condenser coil. Keep all clearance free of any obstruction.
- Refer Pipe Connection Details on Specifications Sheet.
- MTG C-C DIST = Mounting Centre to Centre Distance.
- Use M12 bolt for feet mounting.
- For installation with release height less than or equal to 0.6m, minimum area will be computed based on release height of 0.6m.
- Where A min (the minimum area required) is not satisfied, the installer must provide additional control measure/s in place as per AS/NZS 60335.2.40 standard for the installation to be acceptable.
The examples of controls measures are (but are not limited to): Ventilation, Shut Off Valves and Safety Alarm. These control measures are not provided by ActronAir and must be determined by the installer based on individual installation requirements
- Refer to R-32 Safety Manual for minimum required area of installation.

Unit Lifting Procedure

WARNING

WH&S regulations must be observed and will take precedence during lifting process.

NOTE

All drawings are for illustration purposes only. Actual unit may vary depending on the model.

Crane Lifting Method

Crane lifting method is recommended for high rise lifting.

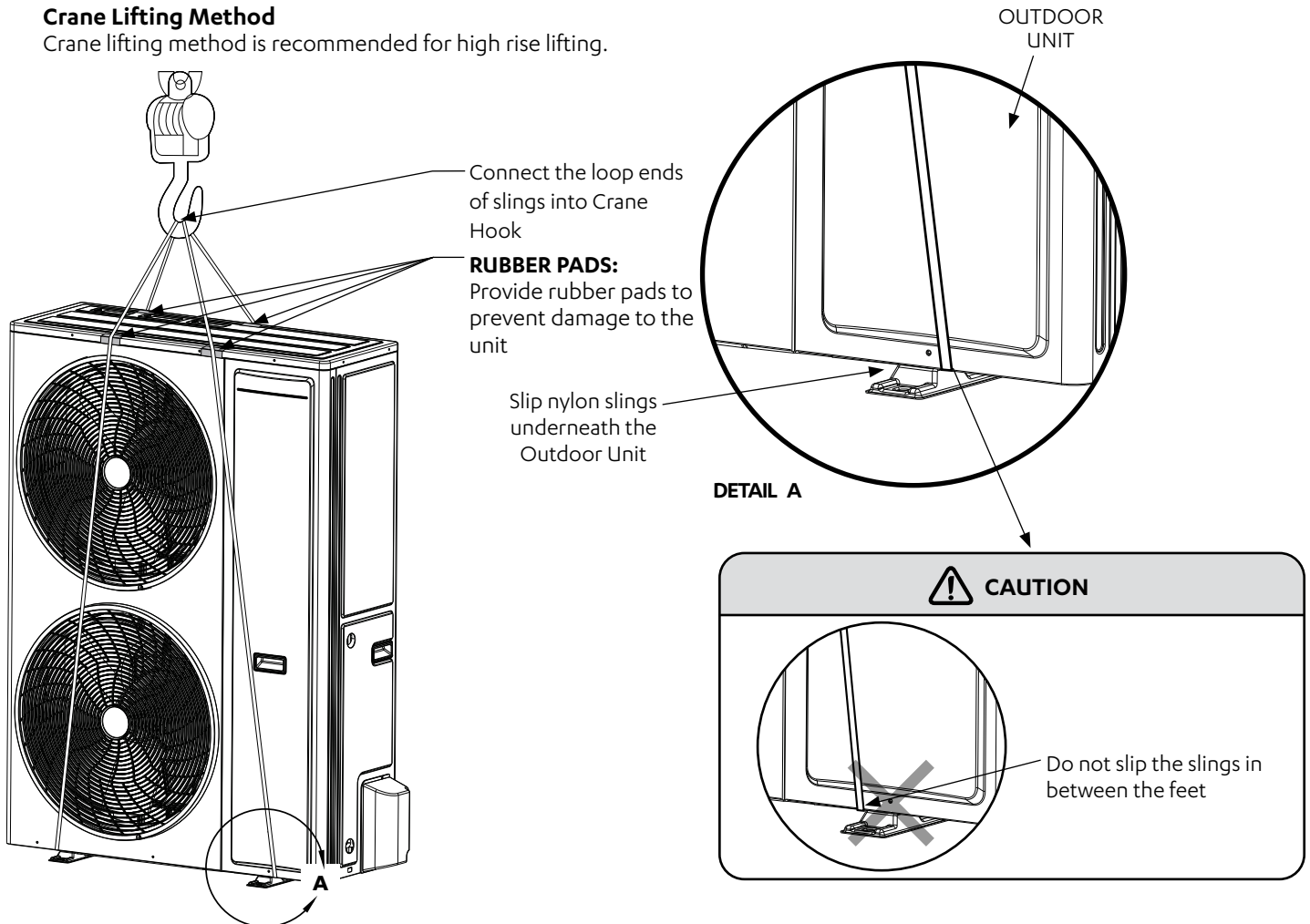

Equipment Required For Crane Lifting:

- 2 x Nylon Slings

NOTE

Refer to Unit Dimensions and Clearances section for unit weight before selecting shackle and slings.

Procedure:

1. Slip nylon slings through the pallet as shown in Fig. 1.
2. Use a Bow or Dee shackle to connect the slings.
3. Ensure slings are protected by rubber pads or similar if slings are draped across unit edges, corners, or air grilles. This will prevent the unit from being damaged during lifting.
4. SPREADER BARS must be used when lifting the unit. Ensure that the spreader bar is slightly larger than the base.
5. Test lift the unit to determine exact unit balance and stability before hoisting it to the installation location.

Outdoor Unit Preparation

WARNING

Live electrical within enclosure. Isolate electrical supply before removing panels.
 Authorised technicians access only.

Step 1: Select installation location

Before installing the outdoor unit, you must choose an appropriate location. Proper installation locations meet the following standards:

1. Meets all spatial requirements.
2. Good air circulation and ventilation.
3. Firm and solid—the location can support the unit and will not vibrate.
4. Noise from the unit will not disturb others.
5. Protected from prolonged periods of direct sunlight or rain.

Step 2: Fix the outdoor unit

When installing the unit on ground level, ensure it is sufficiently fastened to prevent movement and vibration. It is recommended to install vibration rubbers underneath the feet (supplied).

NOTES

Take sufficient protective measures when installing the outdoor unit.
 If the unit is installed on bracket, make sure the support can withstand at least four times of the unit weight.

Step 3 : If drain connection is required

If outdoor unit requires a drain joint, before fixing the outdoor unit in place, you must install the drain joint at the bottom of the unit. Rubber plugs must be fitted to any open drainage holes except in the location of the drain joint. These are supplied with the condenser units.

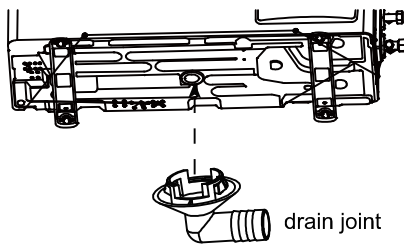

NOTE

If drainage from the condenser is required, the outdoor unit should be installed at least 30 mm above the floor in order to install drain joint.

Step 4: Connect indoor and outdoor pipe

A. CRS10AS to CRS17AS/CRS17AT

1. Remove the screw on the right bottom side of the cover and then remove the cover.

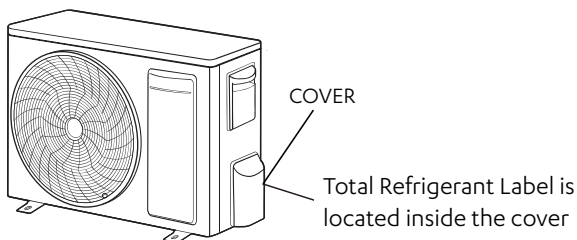

- Remove the screw cap of access valve and aim the pipe joint at the flare end of the pipe.

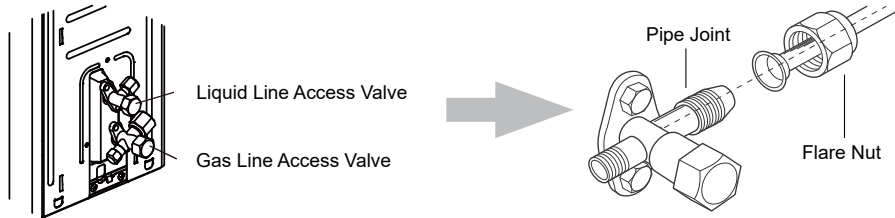

- Pretighten the flare nut with hand.
- Tighten the flare nut with torque wrench.

Pipe Size	Torque (N.m.)
ø 9.52	30 ~ 40
ø 15.88	60 ~ 65
ø 19.05	70 ~ 75
ø 22.22	85 ~ 95

B. CRS20AT to CRS23AT

- Remove the screws on the right bottom side of the panel and remove the cover.

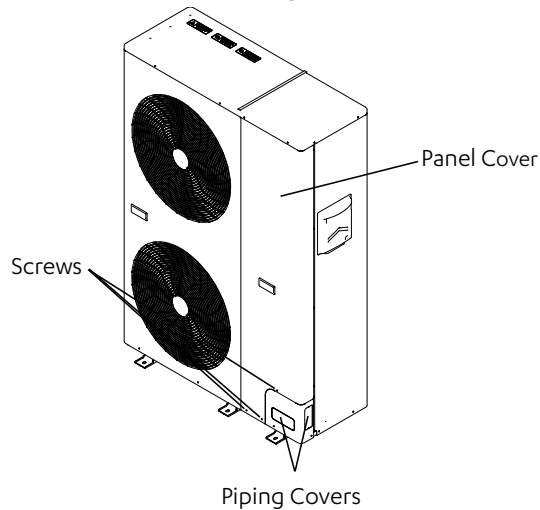

- Select an outlet where the pipe will come out of the unit (front or side) and remove the piping cover.

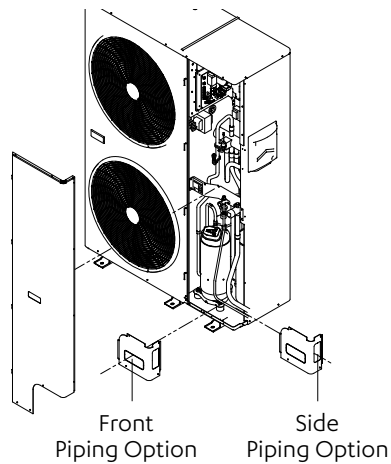

3. Insert connecting pipes (front or side outlet) and bend to specific length.

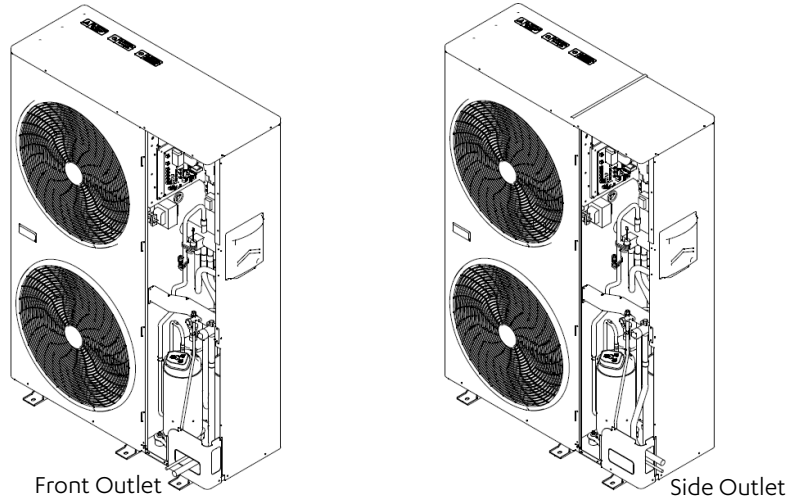

4. Braze pipe to position.

Step 5: Connect indoor and outdoor CABLE

1. Connect the power cable and signal control wire to the wiring terminal according to the colour.

NOTE

After tightening the screw, pull the power cable slightly to check if it is firmly connected.

2. Secure the power cable and signal control cable with cable clip.
3. Use the provided cable tie to secure the wire from contacting the refrigeration components.

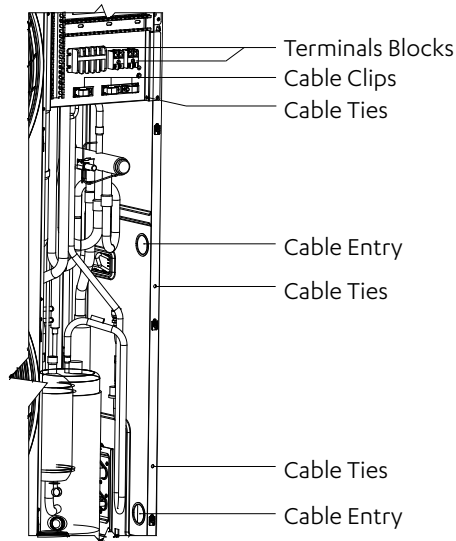

Refer the wiring diagram behind the access panel for electrical wiring between indoor and outdoor units.

NOTE

The power cable and the data cable should not be tied together.

Field Pipe Connection

Piping and Brazing



CAUTION

This outdoor unit described in this guide is designed to match only with an ActronAir indoor unit as specified in the Technical Selection Catalogue.

- The unit is supplied with factory charged refrigerant as stated in the Rating Label. The use of other material as a refrigerant may cause explosion and/or personal injury.
- Be aware of all the relevant regulations concerning the handling of refrigerant.
- The system of this unit operates with Polyester Ester (VG74)* oil.
- The maximum time any system can be opened to atmosphere is 15 minutes.
- It is important to work with absolute cleanliness.
- Secure Hot Work Permit as required.
- Brazing must be done with the use of Nitrogen to avoid carbon deposits into the pipes.
- The system must be evacuated thoroughly to 500 microns (see evacuation procedure).
- Never allow refrigerant to vent into the atmosphere. It is an offence to release refrigerant in Australia.
- Always reclaim refrigerant using equipment and container dedicated for the refrigerant used in the system.
- Only qualified technicians are allowed to perform any work described in this guide and all work must be carried out in accordance with Australia and New Zealand refrigerant handling code of practice.

*The VG74, which means that it rapidly absorbs moisture from the air.

Maximum allowable total equivalent field pipe length is 60 metres, see diagram on the next page. This includes all the equivalent pipe fitting losses and vertical height difference. Vertical height difference must not exceed 20 metres. Table below shows the equivalent straight pipe length of elbow fittings.

TABLE : EQUIVALENT STRAIGHT PIPE LENGTH OF ELBOW FITTINGS (METRES)				
Pipe size Nominal Diameter	90° Long Radius Elbow	90° Short Radius Elbow	45° Long Radius Elbow	45° Short Radius Elbow
9.52 (3/8")	0.24	0.36	0.09	0.14
15.88 (5/8")	0.30	0.45	0.15	0.23
19.05 (3/4")	0.40	0.60	0.18	0.27
22.22 (7/8")	0.46	0.69	0.21	0.32

Selected field pipe sizes must match the recommended sizes in Tables on Refrigeration Piping in the Specification for Refrigeration Section. If the installation requires different field pipe diameter due to different application condition other than recommended, contact ActronAir for advice.

For installations over 40 m, additional 5ml of oil is required for every additional 5 meters.



R-32 REFRIGERANT

- R-32 refrigerant (CLASS A2L) is mildly flammable. Thoroughly read and understand the accompanying R-32 Safety Guide for installation and maintenance instructions.
- Installation, service, maintenance, repairs and decommissioning of this unit must be performed by a licensed HVAC technician; qualified to handle R-32 refrigerant.
Appliance shall be installed, operated and stored in a well ventilated area:
 - where the room size corresponds to the room area as specific for operation.
 - without continuously operating open flames (for example an operating gas appliance) nor ignition sources (for example an operating electric heater).
 - away from other potential continuously operating sources that known to cause ignition of R-32 refrigerant.
 - R-32 refrigerant is odorless if the refrigerant gas comes into contact with fire, it may emit a poisonous gas.

The indoor unit pipe connections are factory swagged to easily fit to the recommended field pipe diameter.

When it is required to install other refrigeration devices, such as refrigerant drier, solenoid valve and the like, include the equivalent straight pipe length of the device in the calculation of total equivalent field pipe length and mechanical connections shall be accessible for maintenance purposes.

Both pipes are required to be insulated.

Improper insulation can result in condensation forming on the pipework's surface, potentially leading to dripping condensation.

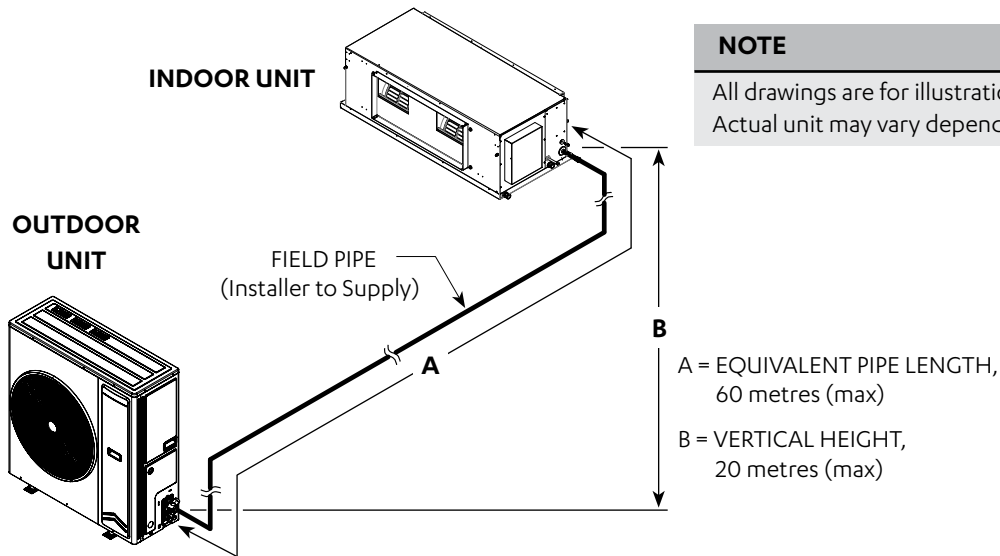

Example of Total Equivalent Field Pipe Length Calculations

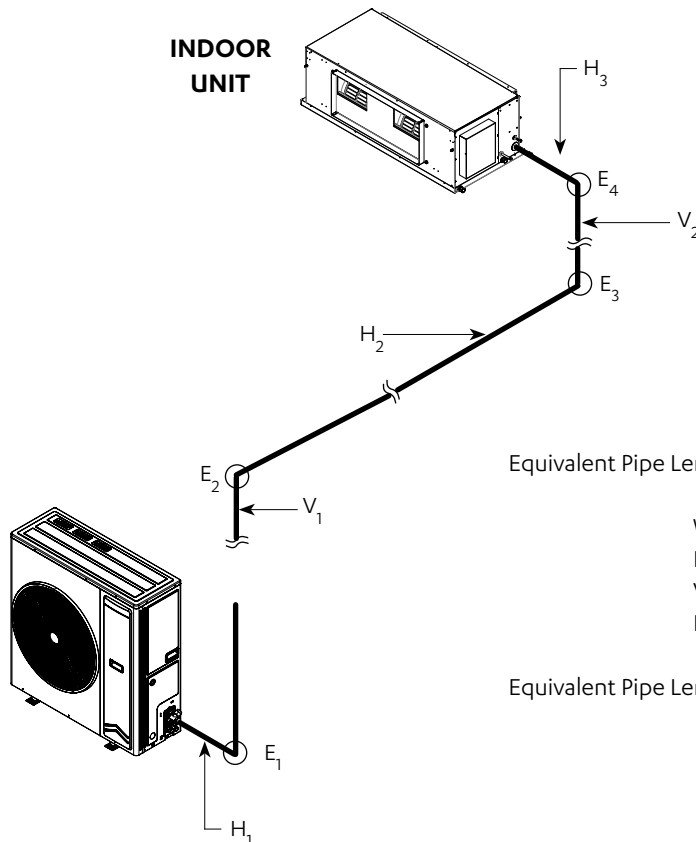

CAUTION

Above illustration shown as calculation examples only. It is the responsibility of the Installer to design an efficient refrigeration piping lay out for optimum unit performance.

Equivalent Pipe Length = Total Horizontal Length + Total Vertical Length + Total Losses from Elbows

Where:

H = Horizontal Length

V = Vertical Length

E = Elbow Losses

$$\text{Equivalent Pipe Length} = (H_1 + H_2 + H_3) + (V_1 + V_2) + (E_1 + E_2 + E_3 + E_4)$$

CAUTION

Brazed joints should only be made while purging Nitrogen through the system. Failure to do so will cause carbon deposit to be left on the internal pipe surface, that in turn can cause system failure and void warranty.

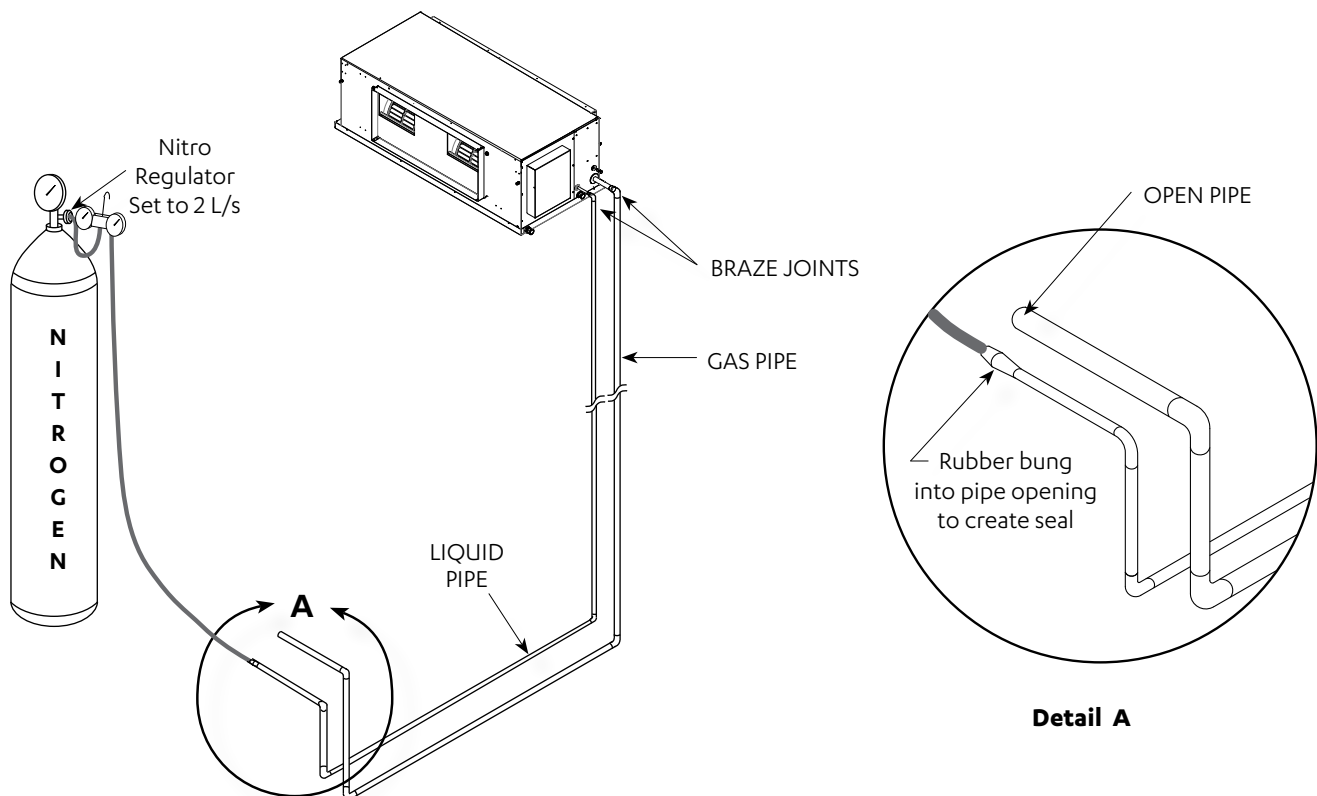

Installing interconnecting pipe work to indoor, nitrogen bleed procedure (First fit or rough in stage only)

1. Run interconnecting pipe work from condenser location to evaporator.
2. Release pressure in evaporator and remove caps.
3. Fit copper tube into tail, set nitro bottle and regulator up at condenser end of pipe work.
4. Fit nitrogen line into liquid line with rubber bung to seal the connection. The seal will prevent air being sucked into pipe work.
5. Leave suction line open, set nitro regulator for nitrogen to flow through pipe work at 2 l/s flow rate @20kPa.
6. Braze required joints as quick as possible. **See Diagram Above.**

Pressure Testing

Pressure test the system between 2500kPa and the system's maximum kPa as determined in **AS/NZS 5149.2:2016, Clause 5.2.2.1 Maximum Allowable Pressure**. Ensure pressure is held for no less than 1 hour.

NOTES

Importance of Evacuation:

- Any non-condensable product left in the system can cause the pressure in the high side of the system to increase and in turn, the compression temperature to rise.
- Moisture will result in adverse reaction in the refrigerant circuit.
- To prevent chemical reactions in the system, any moisture must be removed at all costs.
- Oxygen (air) reacts with the compressor oil and can lead to faults such as compressor failure.

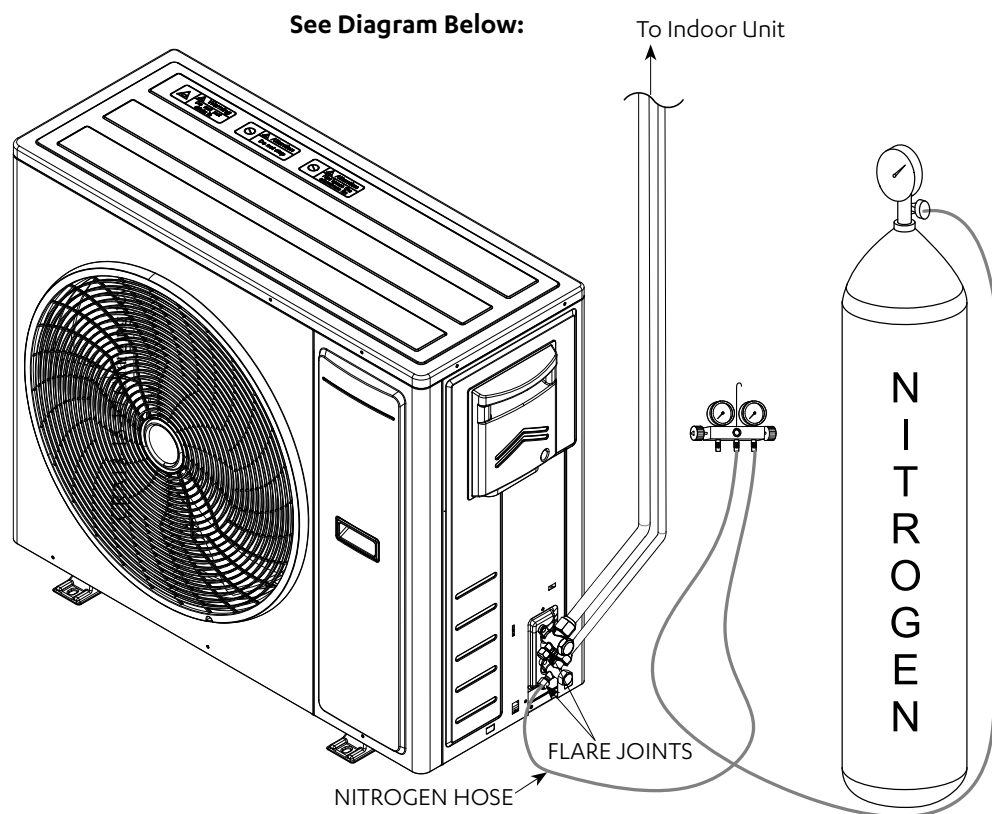

Evacuation Procedure (Triple Evacuation)

1. Fit service gauges to the ball valves (liquid line service valve and suction line service valve).
2. Evacuate the system to 1000 microns.
3. Check vacuum with vacu stat. Break the vacuum with dry Nitrogen to 100kPa.
4. Release Nitrogen pressure. Evacuate to 500 microns.
5. Check vacuum with vacu stat. Break the vacuum with dry Nitrogen to 100kPa.
6. Release Nitrogen pressure. Evacuate to 500 microns.
7. Check vacuum with vacu stat. Let the unit stand for 1 hour and with the vacuum not rising above 500 microns.
8. Open valve.

Electrical Installation

All electrical work must be carried out by a qualified technician. Make sure all wiring is in accordance with local wiring rules. Wiring connections should be made in accordance with the wiring diagram provided.



DANGER

Live Electrical Supply !

- During installation of your air conditioning unit, it may be necessary to work in close proximity to live electricity. Only qualified technicians are allowed to perform these tasks.
- Follow all electrical safety precautions when exposed to live electrical components.
- Always make sure that all power supply, including remote controls, are disconnected before performing maintenance. Observe proper LOCK-OUT / TAG-OUT (LOTO) procedures to ensure that power cannot be inadvertently energised. Failure to disconnect power before maintenance procedure can result in serious injury or death.
- All electrical wiring must be in accordance with the relevant electrical authority rules and regulations.



CAUTION

STATIC SENSITIVE ELECTRONIC DEVICES !

- DO NOT handle electronic devices unless you are wearing an Anti-Static Wrist Strap that is connected to a EARTH. Failure to protect the electronic devices from static electricity may cause unreparable damage.
- Static damaged electronic devices are NOT COVERED for replacement under warranty.

Wiring Diagram

The wiring diagrams specific for your air conditioning system are located on the inside of the electrical access panel.

Always refer all wiring installation, servicing and troubleshooting of this equipment to this diagram to ensure correct electrical connections are satisfied.

Supply and Power Requirements Procedure

It is the installer's responsibility to provide power supply wiring to the sub-mains isolator. Wiring should conform to the current electrical authority regulations and all wiring connections to be as per electrical diagram provided with the unit.

- Confirm that the power supply available is compatible with the unit nameplate ratings. The supply power must be within +6% to -6% of the rated voltage as per AS60335.1.
- Protect electrical service from over current and short circuit conditions in accordance with the latest edition of the AS/NZS 3000 (also known as Australian / New Zealand Wiring Rules). Protection devices are to be sized accordingly as per to the electrical specifications of the unit.
- Complete the outdoor unit power supply wiring into the sub-mains isolator.
- Secure the power cords and control cables that enters in/exits out the unit. Use the cable ties provided in the electrical panels.
- Provide proper unit earthing in accordance with local and national wiring rules.
- Installer to connect an appropriate load break (AC3) isolator in sub mains wiring.

Compressor Voltage Balance Requirement

Check the voltage at the mains supply terminals to determine if it is balanced. Voltage imbalance on three phase systems can cause motor overheating and premature failure. The maximum allowable imbalance is + 2.0% should voltage imbalance exceed this value, check unit wiring connections to locate and rectify faults or contact local supply authority.

Crankcase Heater

Crankcase Heater is to be disconnected for pipe lengths 8m or less.

Wiring Diagram - Outdoor Units

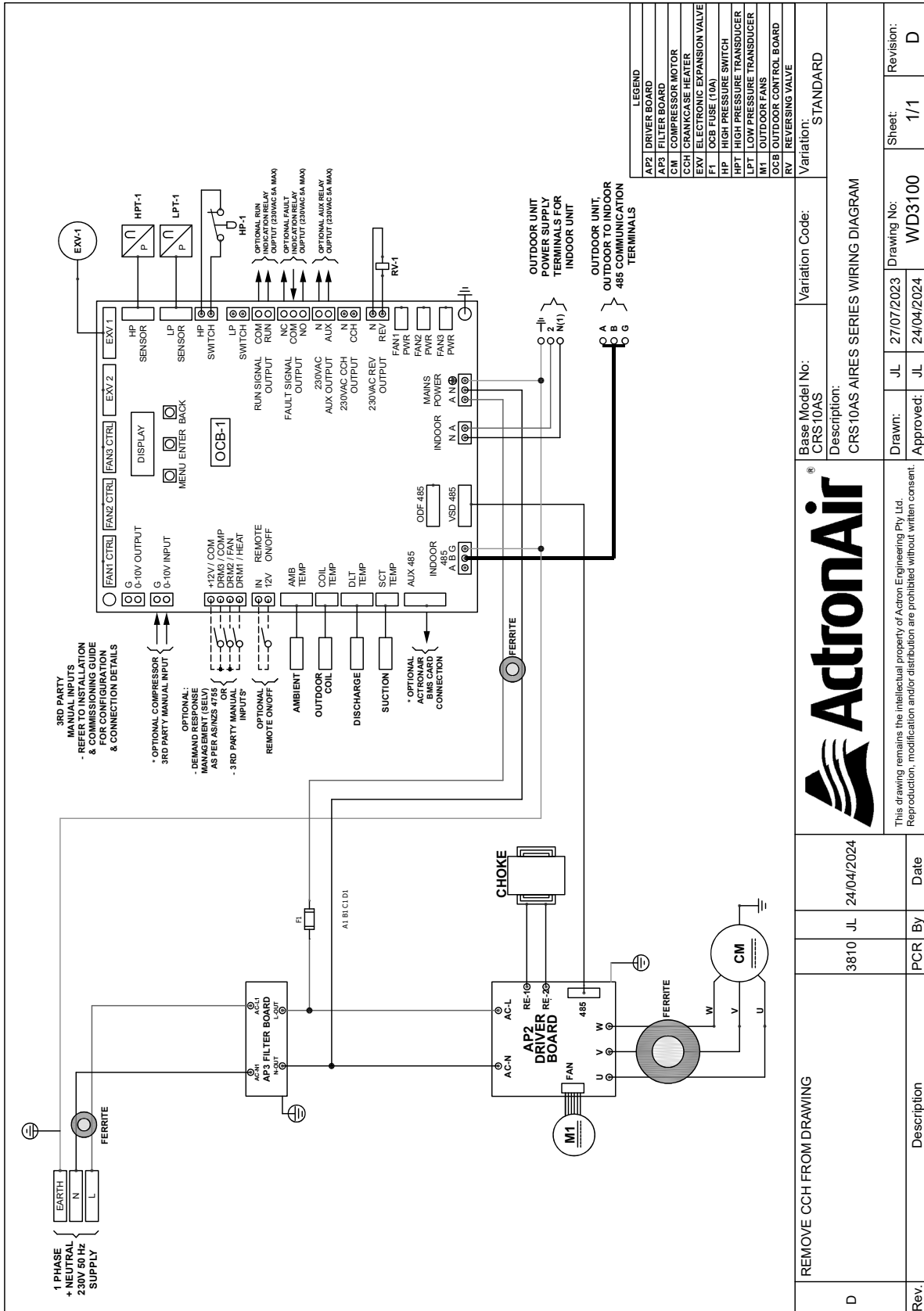

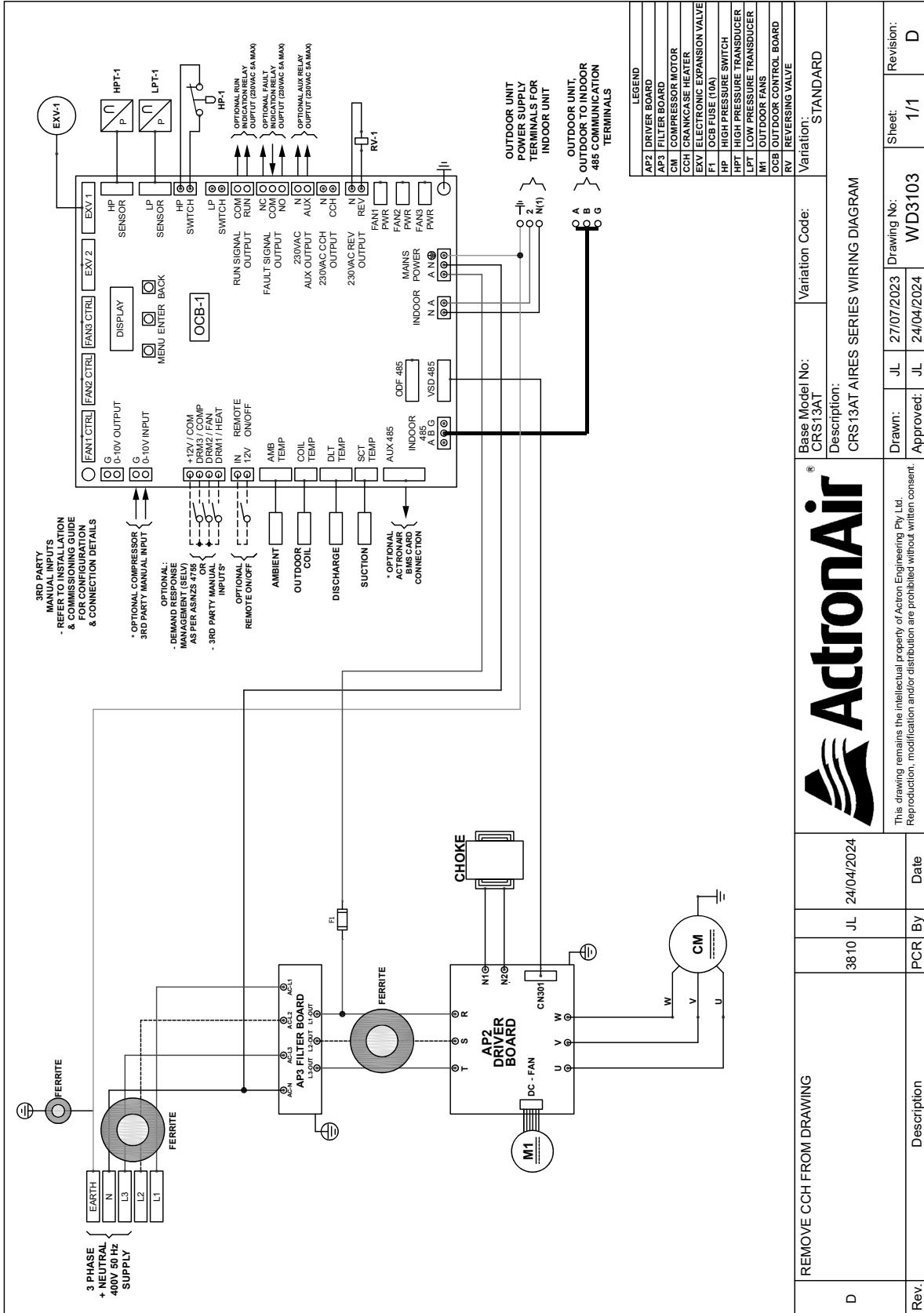

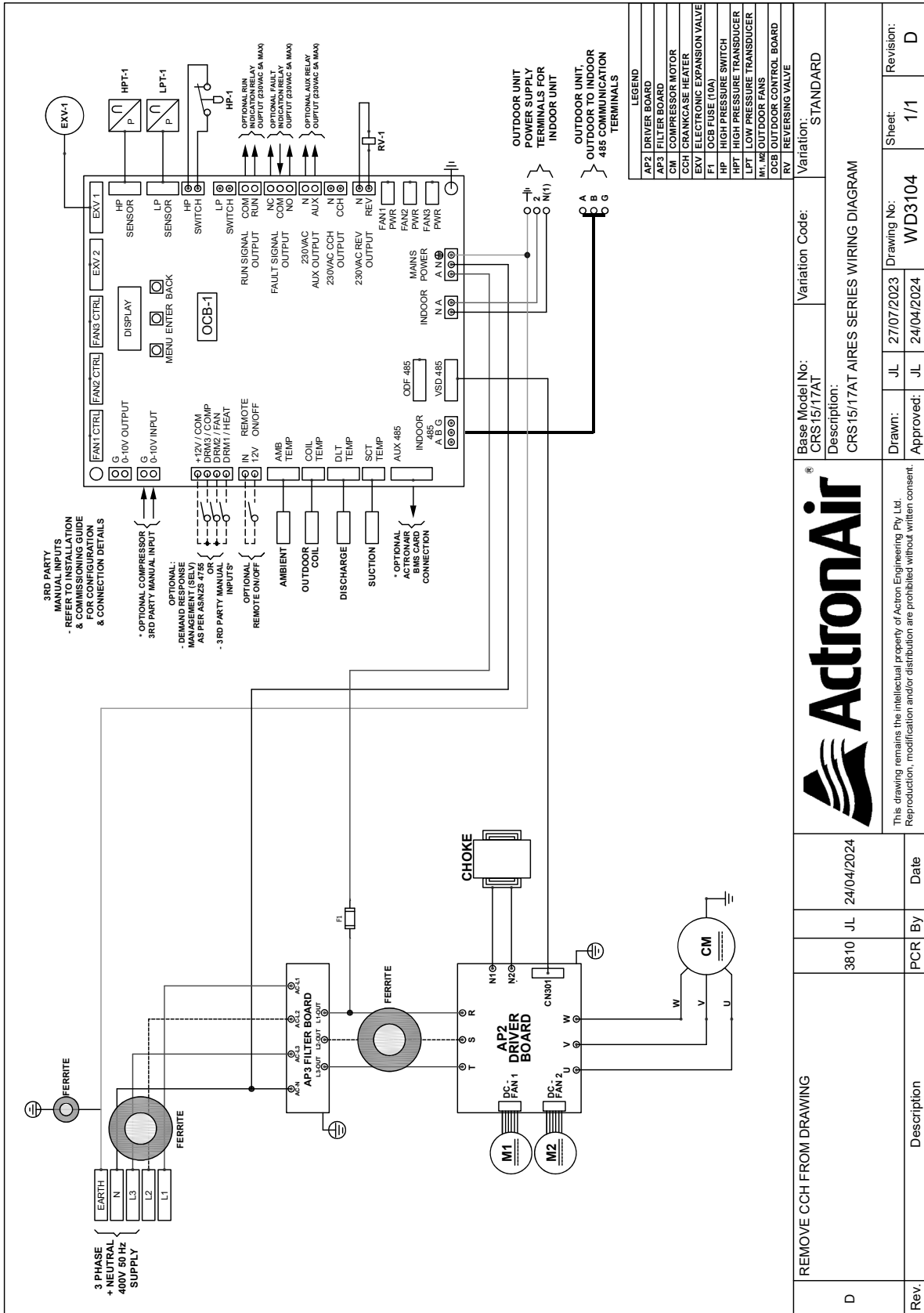

This drawing remains the intellectual property of Actron Engineering Pty Ltd. Reproduction, modification and/or distribution are prohibited without written consent.

REMOVE CCH FROM DRAWING	3810	JL	24/04/2024	PCR	By	Date
Rev.				Description		

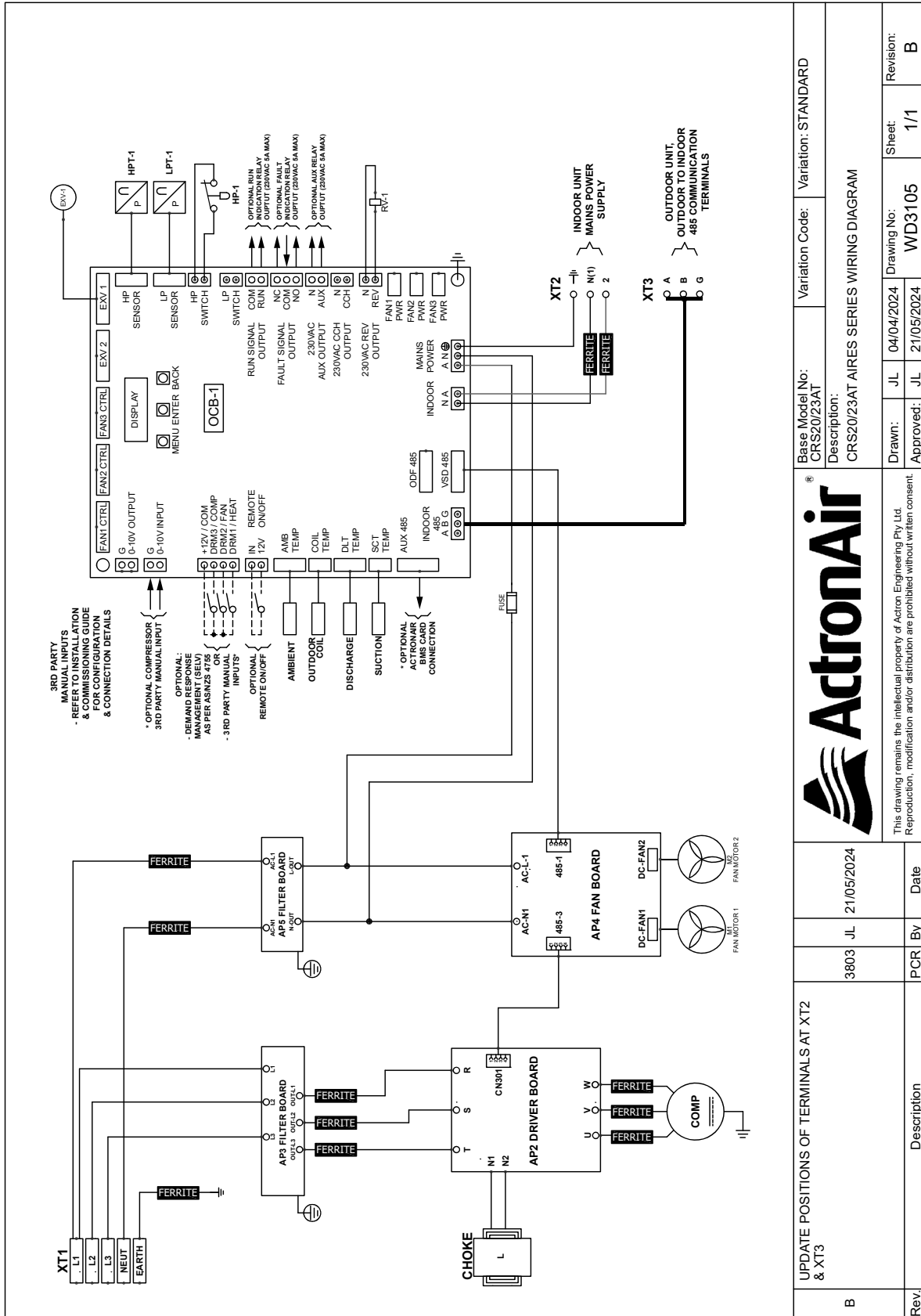

B	UPDATE POSITIONS OF TERMINALS AT XT2 & XT3	3803	JL	21/05/2024			
	Rev.	Description	PCR	By	Date		
Description: CRS20/23AT AIRES SERIES WIRING DIAGRAM		Base Model No: CRS20/23AT		Variation Code: STANDARD		Variation: STANDARD	
Approved:	JL	21/05/2024	WD3105	1/1	Sheet:	Revision: B	
Drawn:	JL	04/04/2024	WD3105	1/1	Sheet:	Revision: B	

This drawing remains the intellectual property of Actron Engineering Pty Ltd. Reproduction, modification and/or distribution are prohibited without written consent.

Wiring Diagram - Indoor Units

Base EVA10AS
Model No.:

Description:
WIRING DIAGRAM INDOOR BOARD + 8 ZONES
WITH 3 WALL CONTROLLERS

Variation Code:

Variation:
STANDARD

This drawing remains the intellectual property of Actron Engineering Pty Ltd. Reproduction, modification and/or distribution are prohibited without written consent.

Drawn: JL	13/05/2024	Drawing No: 0515-1102	Sheet: 1/1	Revision: A
Approved: JL	15/05/2024			

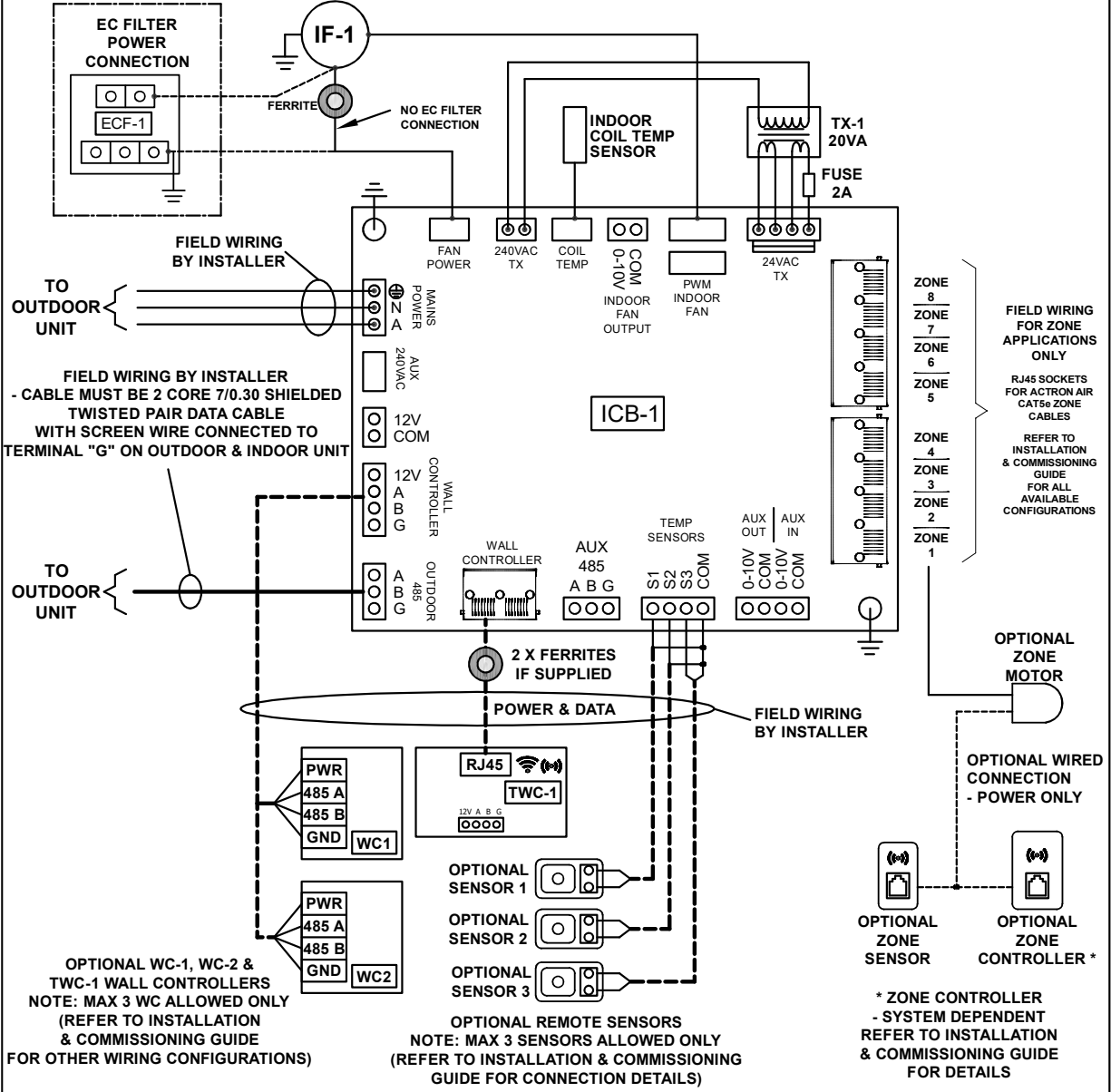

WALL CONTROLLER WIRING

PWR:	- BROWN / ORANGE
485 A:	- BLUE
485 B:	- BLUE-WHITE
GND:	- BROWN-WHITE / ORANGE-WHITE
NOT USED:	- GREEN / GREEN-WHITE

LEGEND

ECF	EC FILTER
IF	INDOOR FAN
ICB	INDOOR CONTROL BOARD
TX	ZONE TRANSFORMER 240/24VAC
TWC	TOUCH WALL CONTROLLER
WC	WALL CONTROLLER



Base Model No.:	EVA/EFA13AS	Variation Code:	Variation: STANDARD		
Description:	WIRING DIAGRAM INDOOR BOARD + 8 ZONES WITH 3 WALL CONTROLLERS				
Drawn:	JL	13/05/2024	Drawing No:	0515-1103	Sheet: 1/1
Approved:	JL	15/05/2024			Revision: A

This drawing remains the intellectual property of Actron Engineering Pty Ltd. Reproduction, modification and/or distribution are prohibited without written consent.

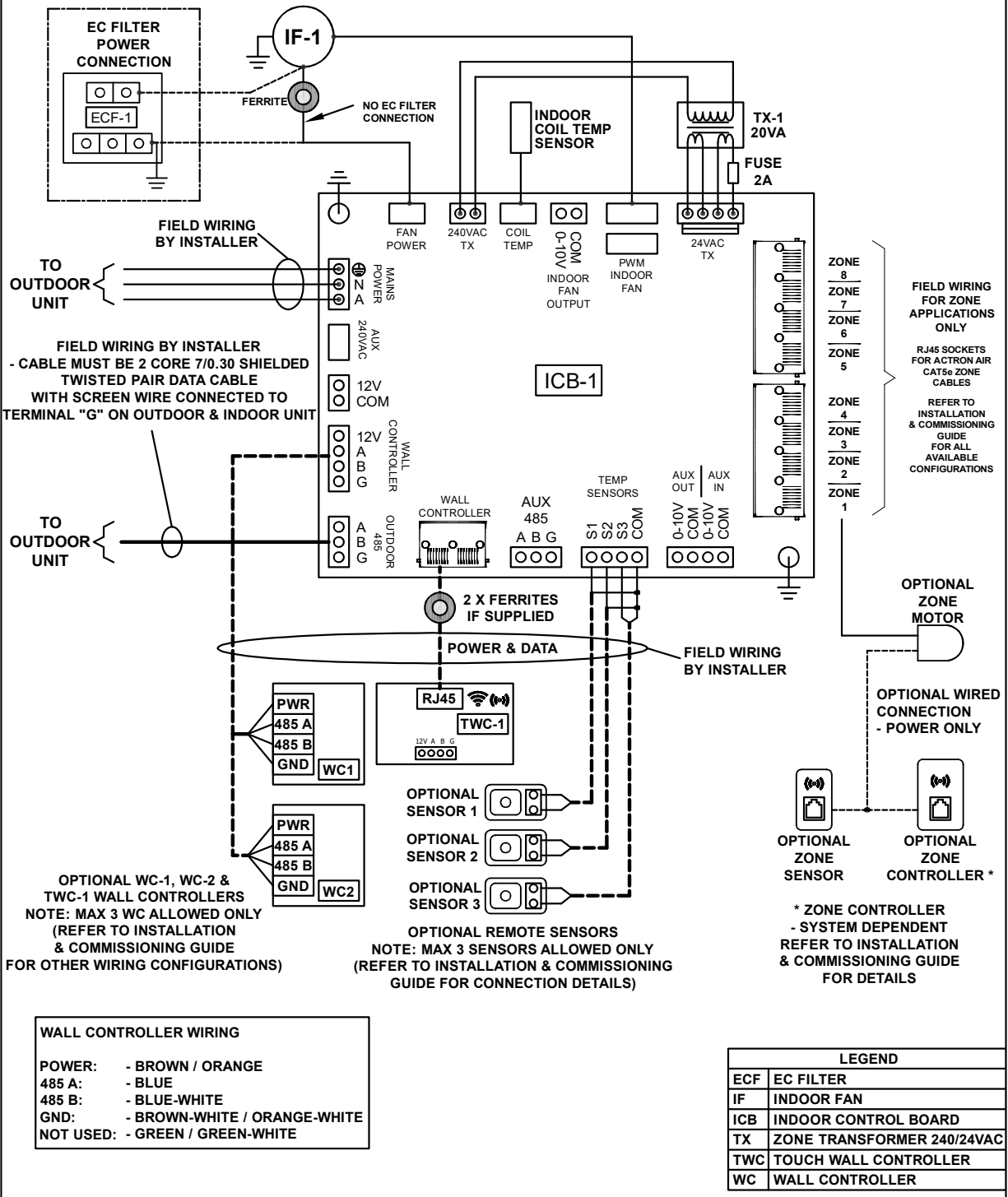



Base Model No.:	EVA/EFA15AS	Variation Code:	Variation: STANDARD		
Description:	WIRING DIAGRAM INDOOR BOARD + 8 ZONES WITH 3 WALL CONTROLLERS				
Drawn:	JL	13/05/2024	Drawing No.:	0515-1104	Sheet: 1/1
Approved:	JL	15/05/2024	Revision:	A	

This drawing remains the intellectual property of Actron Engineering Pty Ltd. Reproduction, modification and/or distribution are prohibited without written consent.

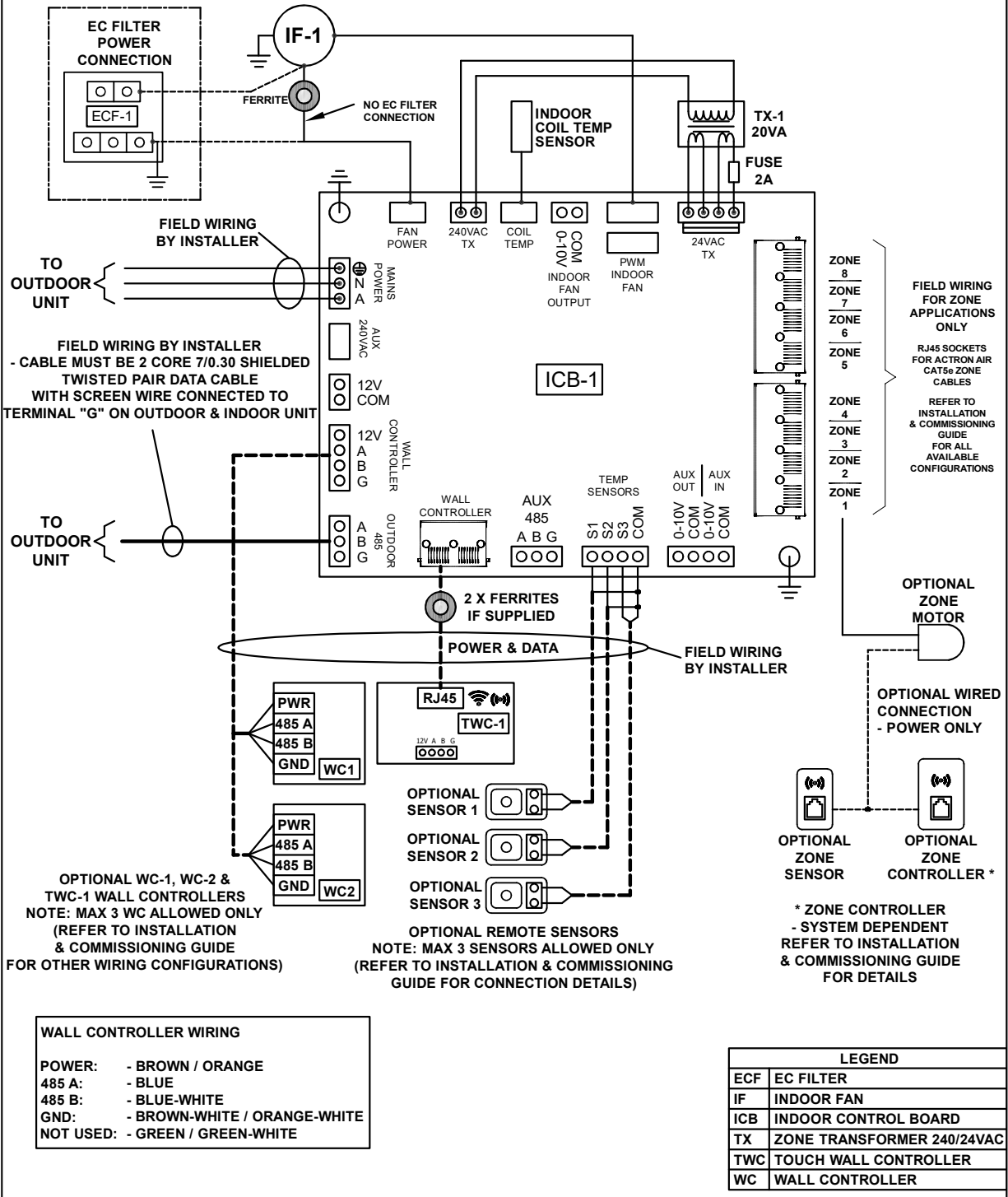



Base	EVA/EFA17AS	Variation Code:	Variation: STANDARD		
Model No.:					
Description:	WIRING DIAGRAM INDOOR BOARD + 8 ZONES WITH 3 WALL CONTROLLERS				
Drawn:	JL	13/05/2024	Drawing No:	0515-1105	Sheet: 1/1
Approved:	JL	15/05/2024	Revision: A		

This drawing remains the intellectual property of Actron Engineering Pty Ltd. Reproduction, modification and/or distribution are prohibited without written consent.

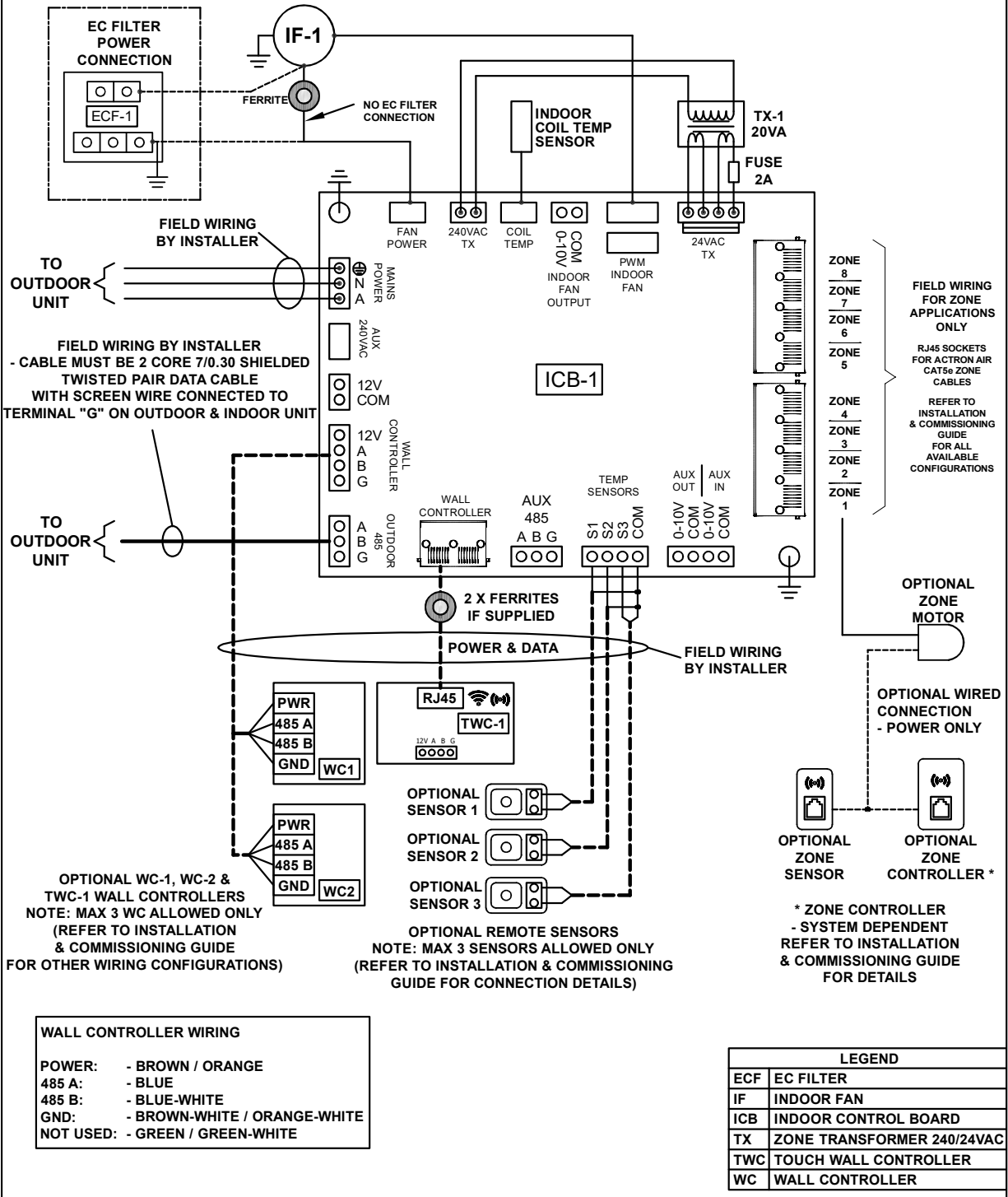



Base Model No.:	EVA/EFA20AS	Variation Code:	Variation: STANDARD		
Description:	WIRING DIAGRAM INDOOR BOARD + 8 ZONES WITH 3 WALL CONTROLLERS				
Drawn:	JL	01/05/2024	Drawing No:	0515-1101	Sheet: 1/1
Approved:	JL	15/05/2024	Revision: A		

This drawing remains the intellectual property of Actron Engineering Pty Ltd. Reproduction, modification and/or distribution are prohibited without written consent.

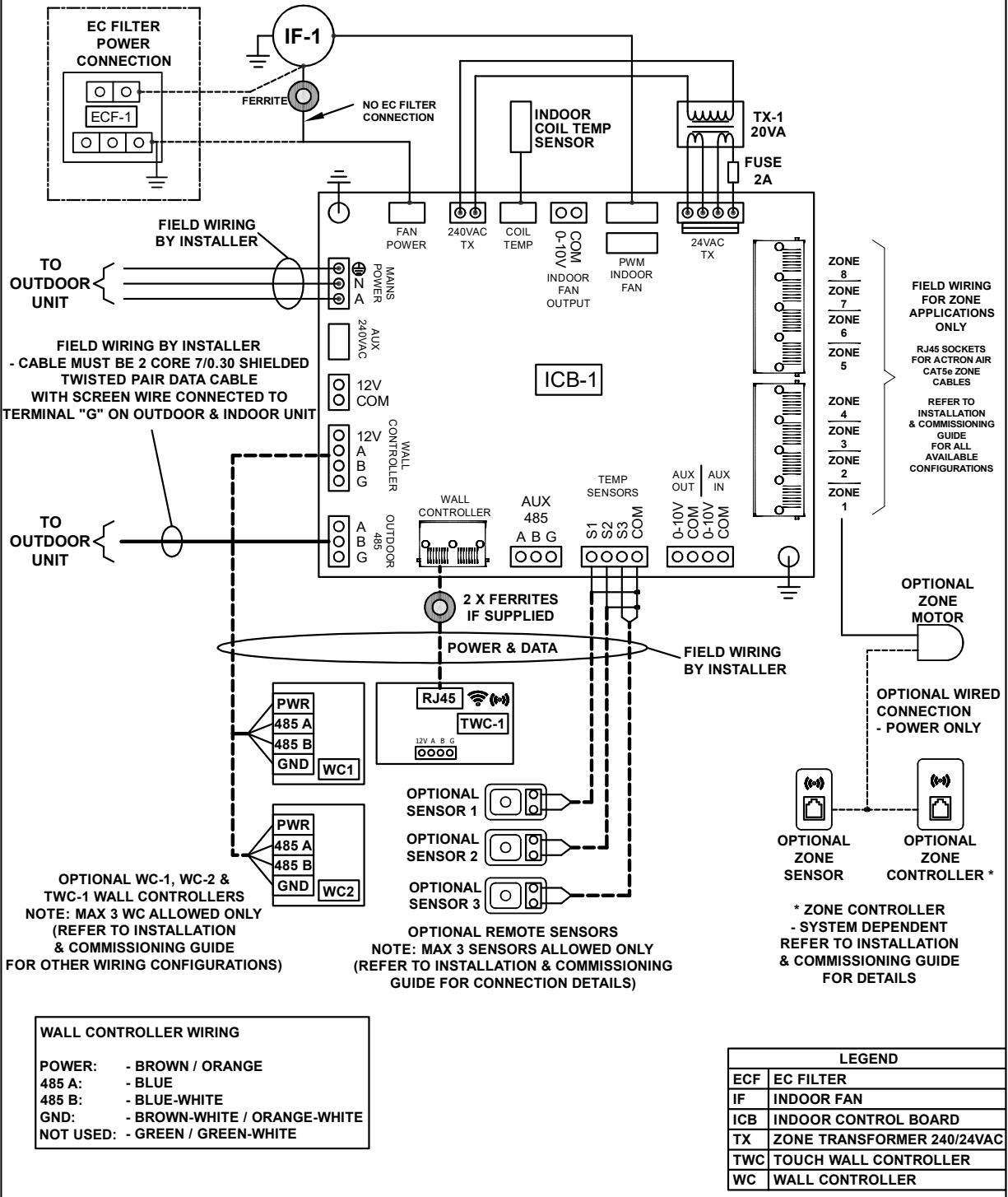



Base Model No.:	EVA/EFA23AS	Variation Code:	Variation: STANDARD		
Description:	WIRING DIAGRAM INDOOR BOARD + 8 ZONES WITH 3 WALL CONTROLLERS				
Drawn:	JL	13/05/2024	Drawing No.:	0515-1100	Sheet: 1/1
Approved:	JL	15/05/2024	Revision:	A	

This drawing remains the intellectual property of Actron Engineering Pty Ltd. Reproduction, modification and/or distribution are prohibited without written consent.

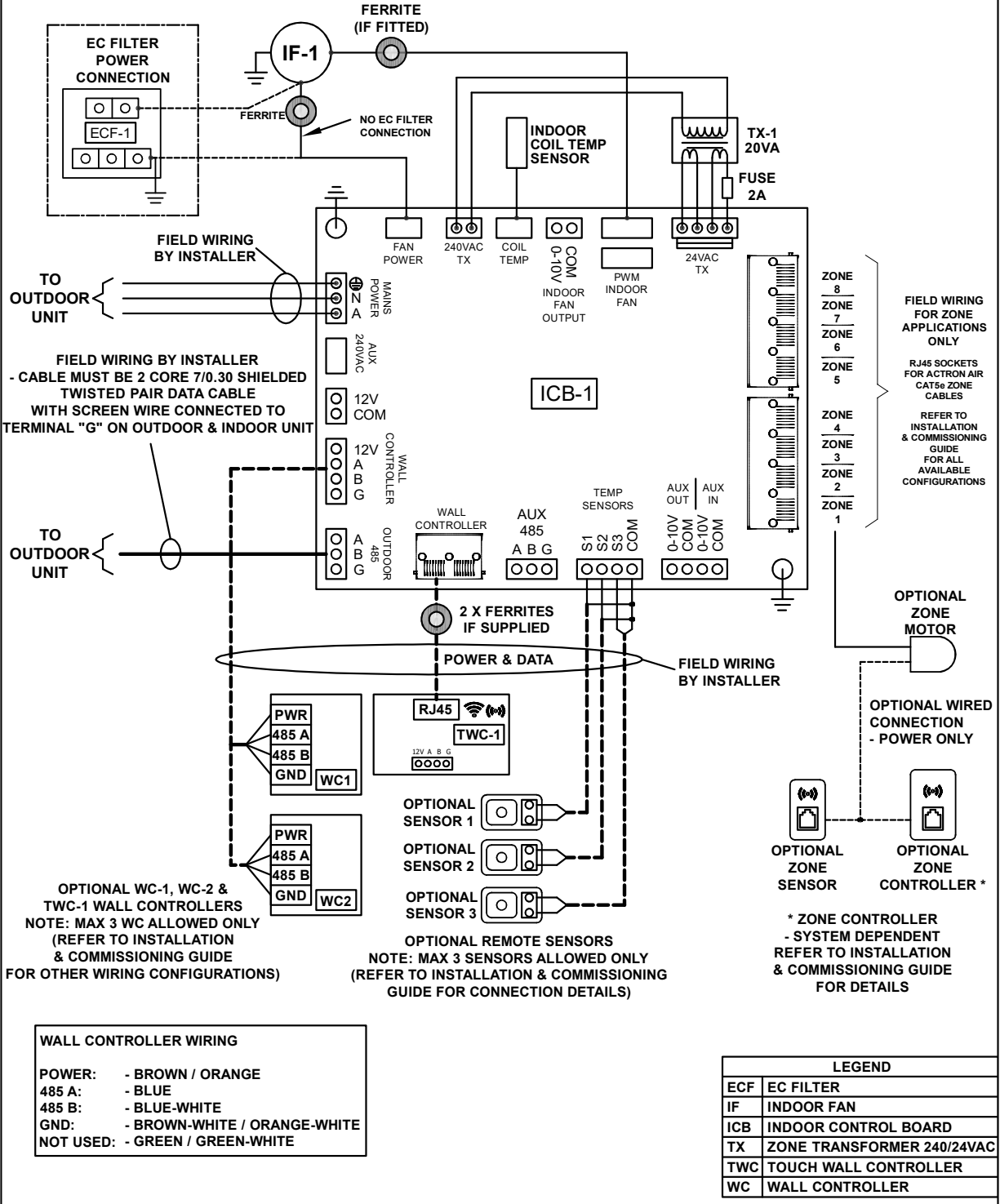

Electrical Connection

NOTES

- To minimise noise interference, Data and Power cable clearance should be maintained as much as possible.
- All drawings are for illustration purposes only. Actual unit may vary depending on the model.
- All electrical components do not come with the unit, must be purchased separately.

DETAILED WIRING DIAGRAM IS PROVIDED WITH THE UNIT.

Outdoor Unit: Located at the back of electrical/compressor access panel.
 Indoor Unit: Located at the back of electrical box cover.

SPLIT UNIT

- ① MAINS WIRING (230/400VAC)
 (Single Phase + Neutral + Earth) 50Hz
 (Three Phase + Neutral + Earth) 50Hz
- ② INTER-CONNECTING POWER CABLE (230VAC)
 (Single Phase + Neutral + Earth) 50Hz
- ③ DATA CABLE TO WALL CONTROLLER
 (Cat5e UTP (AWG 24) Data Cable)
- - - - ④ EXTRA LOW VOLTAGE DATA CONTROL WIRING
 (2 Core Shielded Twisted Pair 7/0.30 (0.5mm²) Data Cable)

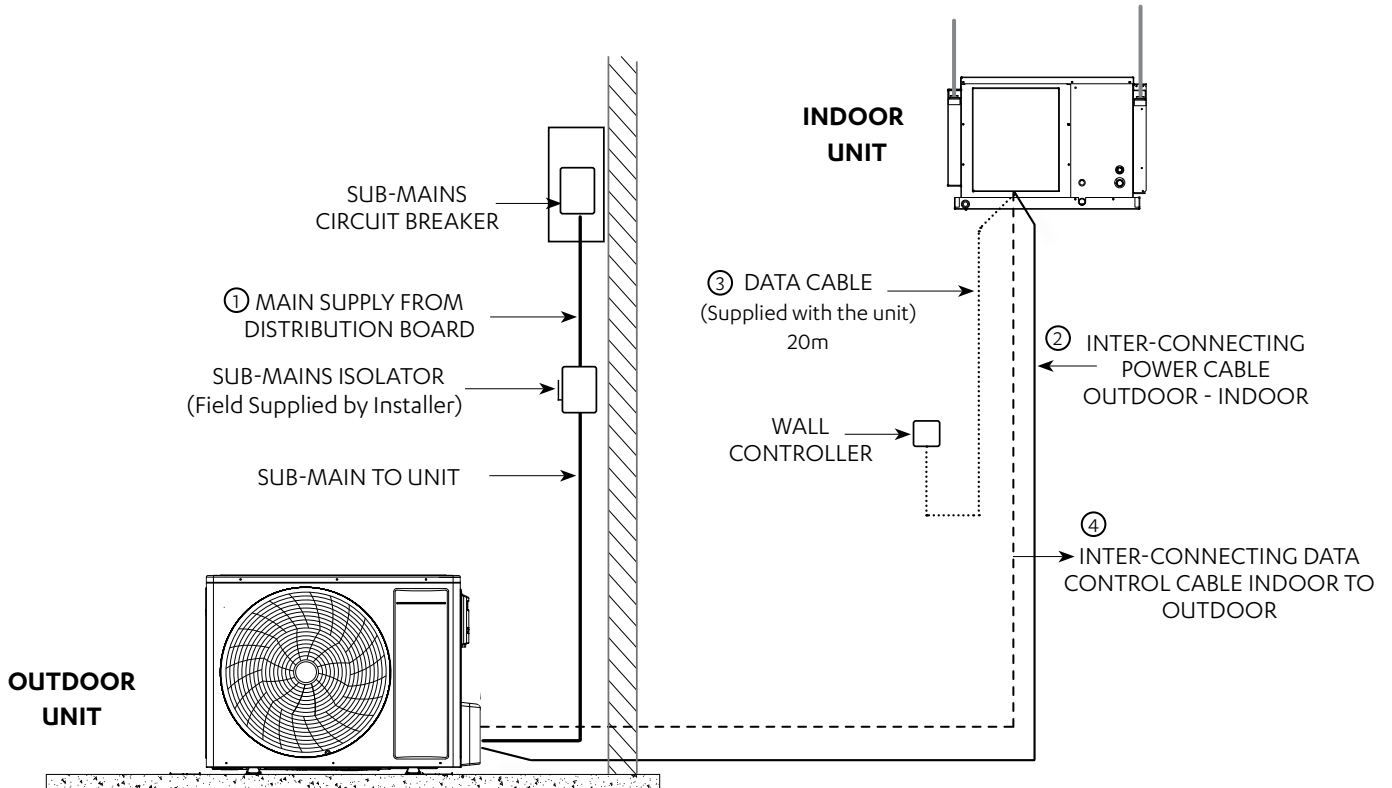

Data Cable Shielding Instructions

2 Core Twisted (ActronAir Part Number: AEDC2)

NOTES

- Maximum strip length of outer insulation to the Green Terminal Plug is 50mm.
- Make sure the cable colors used for the Data Terminal in Outdoor Unit match the Data Terminal in Indoor unit.

Outdoor Unit Data Terminal

“Terminal A” - White Wire

“Terminal B” - Black Wire

“Terminal G” - Shield Wire

Indoor Unit Data Terminal (Green Plug)

“Terminal A (+)” - White Wire

“Terminal B (-)” - Black Wire

“Terminal G” - Shield Wire

Insert data cable through the cable entry. Use provided cable ties and cable clips to secure the wire from contacting the refrigeration components.

NOTE

The power cable and the data cable should not be tied together.

Connect core wires and shield wire into the Outdoor - Indoor 485 Communication Terminal. Refer to Outdoor Unit Installation Commissioning Guide for the location of the Outdoor - Indoor 485 Communication Terminal of the specific model.

(Refer to unit wiring diagram for complete wiring connection details).

NOTE

All drawings are for illustration purposes only. Actual unit may vary depending on the model.

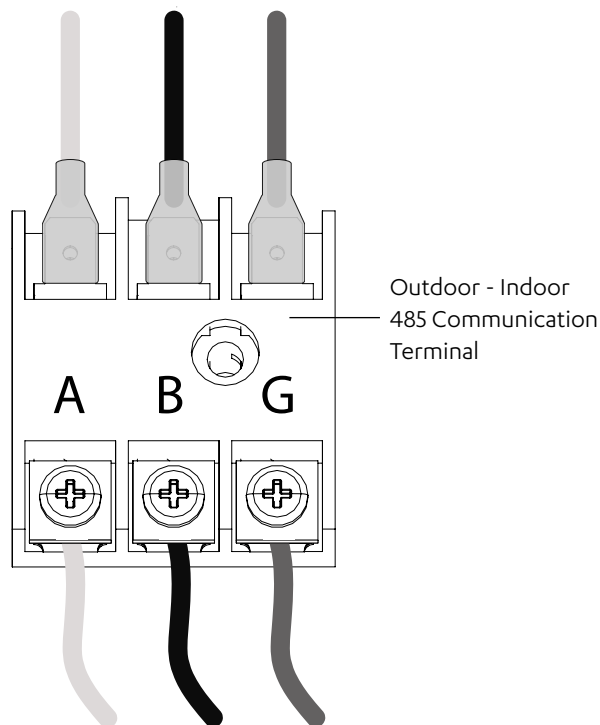

Circuit Breaker Size Recommendation

Outdoor / Indoor Model Number	Circuit Breaker Size Amps
CRS10AS / EVA10AS	25A
CRS13AS / EVA13AS EFA13AS	25A
CRS15AS / EVA15AS EFA15AS	32A
CRS17AS / EVA17AS EFA17AS	32A
CRS13AT / EVA13AS EFA13AS	16A
CRS15AT / EVA15AS EFA15AS	16A
CRS17AT / EVA17AS EFA17AS	16A
CRS20AT / EVA20AS EFA20AS	20A
CRS23AT / EVA23AS EFA23AS	20A

Note:

Refer to latest edition of AS/NZS 3000 or AS/NZS 3008 Australian/New Zealand Wiring Rules to determine required cable size.

Wall Controller Options

Wall Controller Options

A maximum of three (3) wall controllers in the below combinations is allowed per unit. See below table.

Options	Wall Controllers		
	C1	C2	C3
1st Option	NEO		
2nd Option	NEO	NEO	
3rd Option	NEO	NEO	LR7-1 / LC7-2
4th Option	NEO	LR7-1 / LC7-2	
5th Option	NEO	LR7-1 / LC7-2	LR7-1 / LC7-2
6th Option	LR7-1 / LC7-2		
7th Option	LR7-1 / LC7-2	LR7-1 / LC7-2	
8th Option	LR7-1 / LC7-2	LR7-1 / LC7-2	LR7-1 / LC7-2

NOTES

- NEO - Available in White (NTW-1000) and Black (NTB-1000).
- LC7-2, LR7-1 and LM-RS-2 - Available in White and Grey.
- In the instance of a combination of NEO and LR7-1 / LC7-2 being connected together, the NEO will always need to be addressed as C1.

Wiring Configuration : Recommended

NOTES

- Diagram shown below is a general representation only. Refer to individual unit wiring diagram for complete wiring connection details.
- Long runs beside Mains cables or TV antenna cables should be avoided.
- Wiring configuration for LR7-1 and LC7-2 wall controller is the same.
- Daisy connection is not allowed for the NEO wall controller.
- Two Ferrite Clips*, if supplied, are to be placed 200mm and 400mm from the NEO controller respectively.

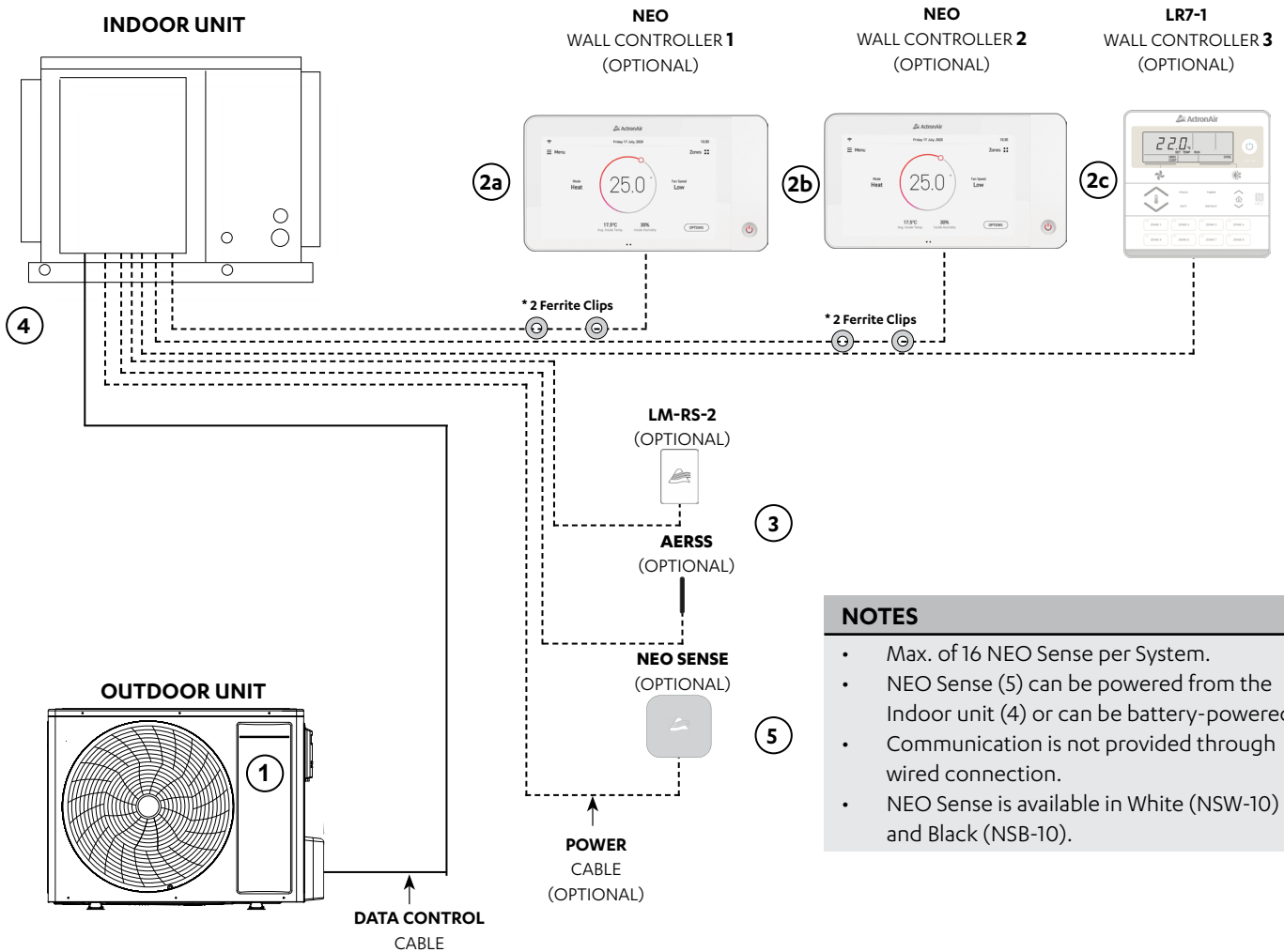

NOTES

- Max. of 16 NEO Sense per System.
- NEO Sense (5) can be powered from the Indoor unit (4) or can be battery-powered.
- Communication is not provided through wired connection.
- NEO Sense is available in White (NSW-10) and Black (NSB-10).

Item	Description	Maximum Cable Length
1 to 4	Outdoor PCB to Indoor PCB	100 m
4 to 2a, 4 to 2b	Indoor PCB to Wall Controller	90 m
4 to 2c	Indoor PCB to Wall Controller 3	100 m
4 to 3	Indoor PCB to Remote Sensor	100 m
4 to 5	Indoor PCB to ZS	100 m

Description	Cable Type
Indoor to Wall Controller	Cat5e UTP (AWG 24) Data Cable
Indoor to Remote Sensor	Cat5e UTP (AWG 24) Data Cable
Indoor to Outdoor Data Cable	2 Core (1 Pair) Twisted Pair, 7/0.30 (0.5mm ²) Shielded Data Cable

Wiring Configuration : Alternate

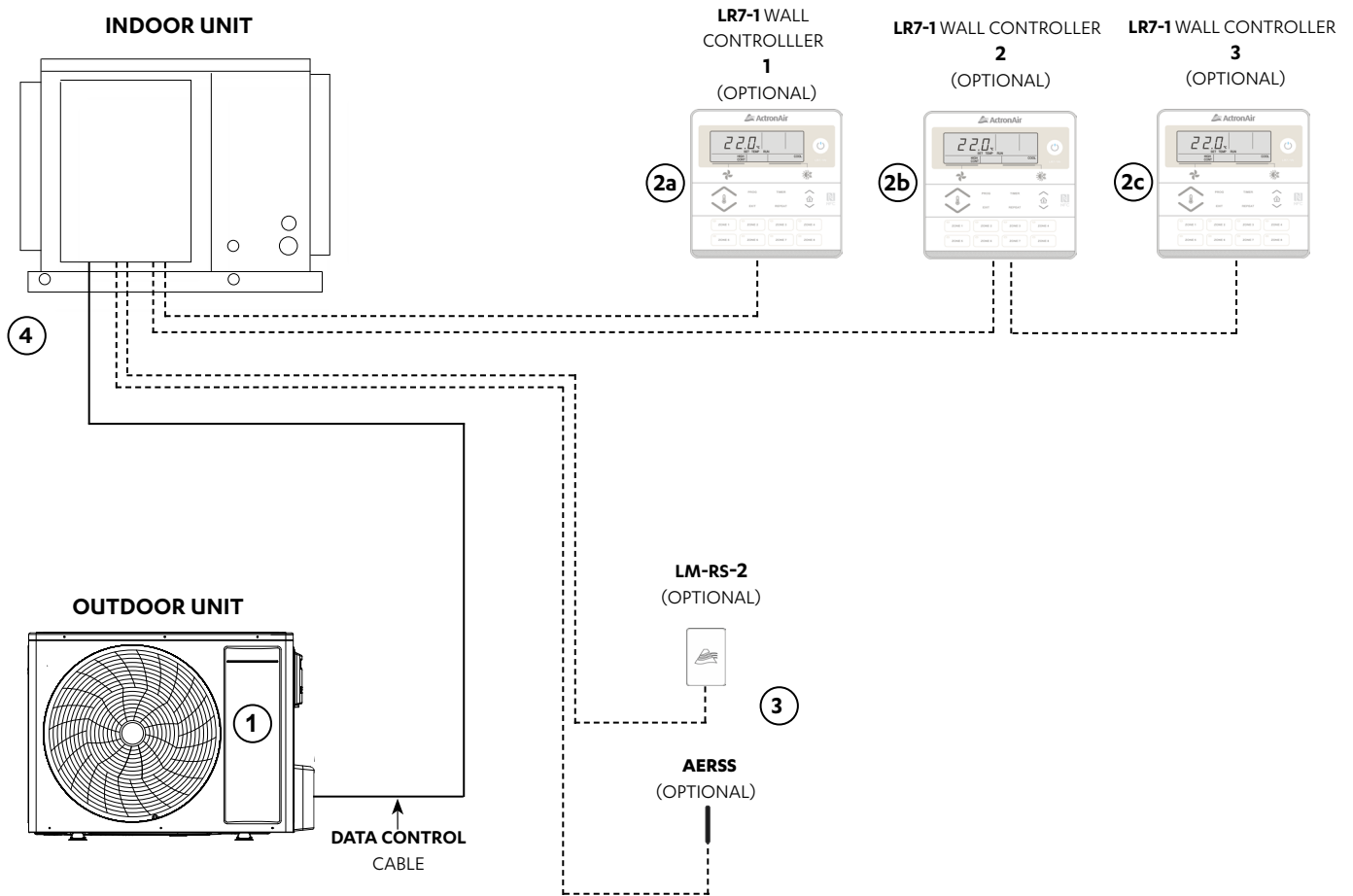

NOTES

- Diagram shown above is a general representation only. Refer to individual unit wiring diagram for complete wiring connection details.
- Long runs beside Mains cables or TV antenna cables should be avoided where possible.
- Wiring configuration for LR7-1 and LC7-2 wall controller is the same.

Item	Description	Maximum Cable Length
1 to 4	Outdoor PCB to Indoor PCB	100 m
4 to 2a	Indoor PCB to Wall Controller 1	100 m
4 to 2c	Indoor PCB to Wall Controller 3 (last controller)	75m total (Daisy Chain)**
4 to 3	Indoor PCB to Remote Sensor	100 m

** Maximum Daisy Chain connection is up to 2 wall Controls.

Description	Cable Type
LR7-1 Field Control Wiring	Cat5e UTP (AWG 24) Data Cable
Indoor to Remote Sensor	Cat5e UTP (AWG 24) Data Cable
Indoor to Outdoor Data Cable	2 Core (1 Pair) Twisted Pair, 7/0.30 (0.5mm ²) Shielded Data Cable

Wiring Connections

LR7-1 and LC7-2 Wall Control Wiring Connections

WALL CONTROL WIRING

POWER: - BROWN / ORANGE
 485 A: - BLUE
 485 B: - BLUE-WHITE
 GND: - BROWN-WHITE / ORANGE-WHITE
 NOT USED: - GREEN / GREEN-WHITE

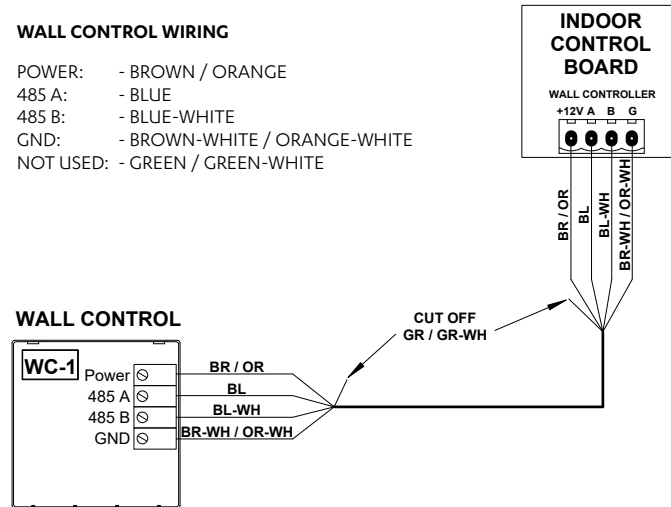

NEO Wall Control Wiring Connections

NOTES

Two FERRITE CLIPS, if supplied, should be installed 200 mm away and FERRITE 2 should be 400 mm away from the Wall Control.

NEO Hard Wiring

WALL CONTROL WIRING

POWER: - BROWN / ORANGE
 485 A: - BLUE
 485 B: - BLUE-WHITE
 GND: - BROWN-WHITE / ORANGE-WHITE
 NOT USED: - GREEN / GREEN-WHITE

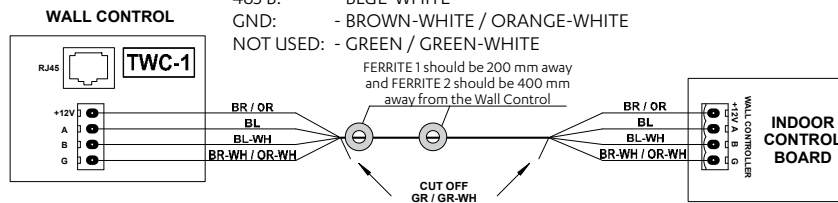

NEO RJ45 Wiring

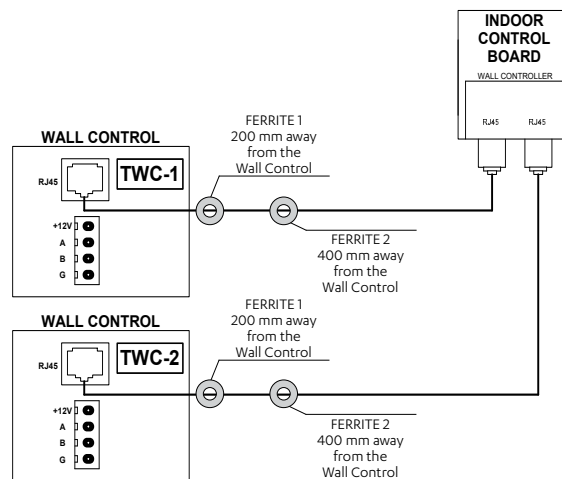

LM-RS-2 Optional Sensor Wiring Connections

REMOTE SENSOR WIRING

- PAIR 1: - BLUE / BLUE-WHITE
- PAIR 2: - ORANGE / ORANGE-WHITE
- PAIR 3: - GREEN / GREEN-WHITE
- PAIR 4: - BROWN / BROWN-WHITE

NOTE:

- PAIR 1 AND 2 USED FOR ILLUSTRATION PURPOSES ONLY.
- CUT OFF AND TERMINATE ANY UNUSED PAIRS TO ENSURE NO WIRING IS LEFT EXPOSED.

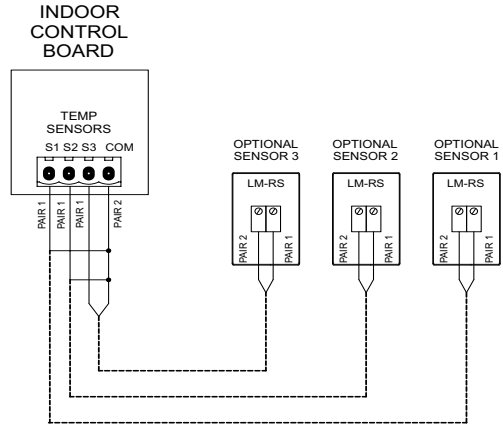

AERSS Optional Duct Sensor Wiring Connections

REMOTE SENSOR WIRING

- PAIR 1: - BLUE / BLUE-WHITE
- PAIR 2: - ORANGE / ORANGE-WHITE
- PAIR 3: - GREEN / GREEN-WHITE
- PAIR 4: - BROWN / BROWN-WHITE

NOTE:

- PAIR 1 AND 2 USED FOR ILLUSTRATION PURPOSES ONLY.
- CUT OFF AND TERMINATE ANY UNUSED PAIRS TO ENSURE NO WIRING IS LEFT EXPOSED.

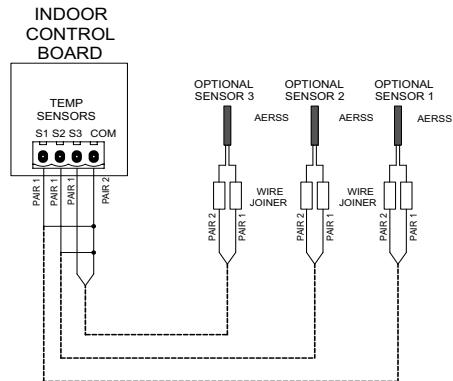

Demand Response Management

These products are compliant to AS/NZS 4577.3.1:2012

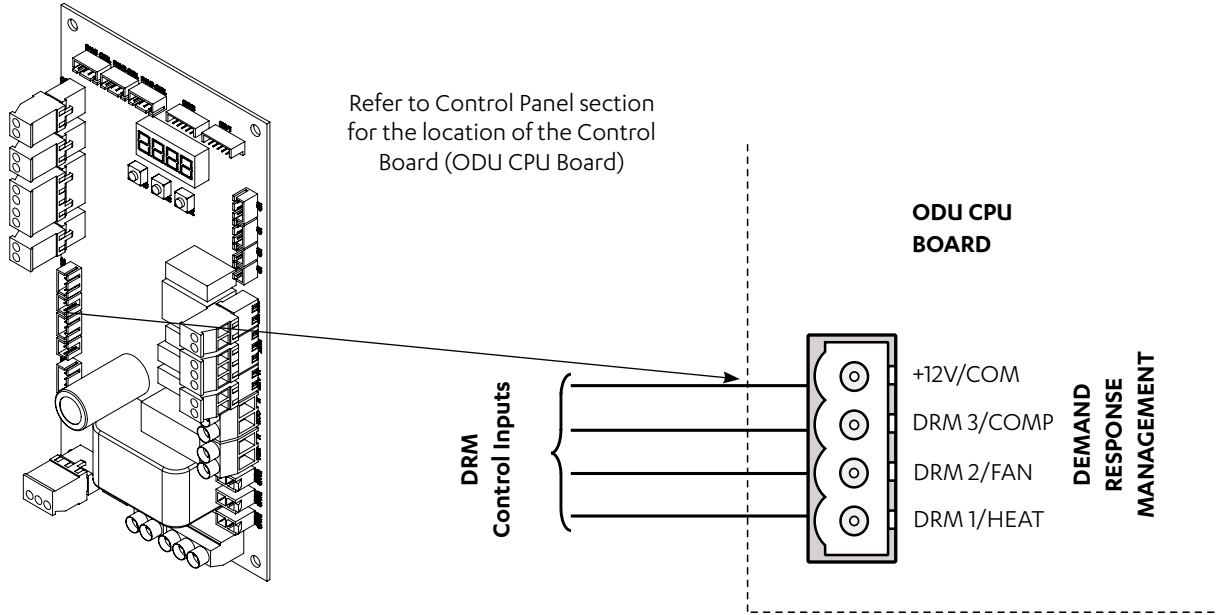

1. Route DRM input cables into the Unit (as per previous wiring installation procedure).
2. Connect cables into terminals (as per wiring diagram provided with the unit).

Demand Management Mode	Description Of Mode Allowable Range (%)	Operating Mode
DRM1	Compressor Off Mode	Compressor <u>ONLY</u> will cycle Off and remain Off for the entire Demand Response event. All other functions will operate as normal (i.e. Indoor Fan)
DRM2	Maximum 50% power use mode with 0 to <50% allowable power use range	Compressor 0 to <50% operation range for the total Demand Response event.
DRM3	Maximum 75% power use mode with 0 to <75% allowable power use range	Compressor 0 to <75% operation range for the total Demand Response event.

DEMAND RESPONSE ENABLING DEVICE CIRCUIT DIAGRAM

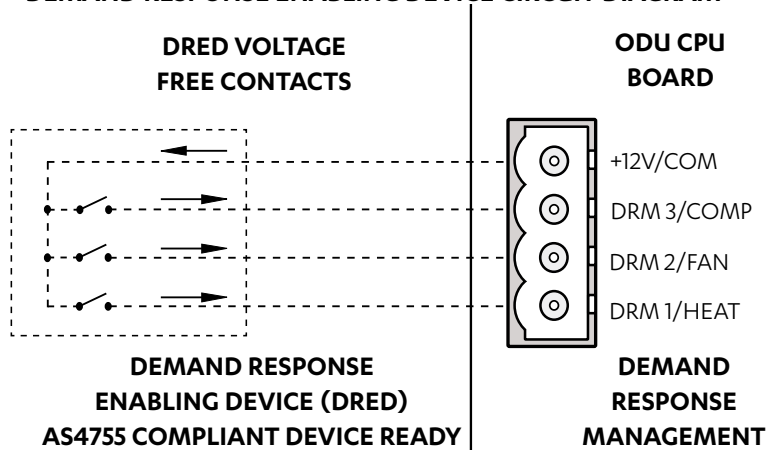

NOTES

- Demand Response Management is not applicable when using third party control.
- Contact your electricity authority to install and activate DRED.
- All drawings are for illustration purposes only. Actual unit may vary depending on the model.

Configuring and Commissioning Setup

Menu and Navigation

dis (Display)	Display system's status and settings		
SEr (Service)	Service use only		
SEt (Settings)	cnFg	03.00 = Family*	
		03.00 = Capacity*	
		CtrS	Ct. 0 = 3rd Party
			Ct. 1 = Wall Control (default)
			Ct. 2 = Basic BMS
	Ct. 3 = Wall Control + Basic BMS		
	Ct. 4 = Advanced BMS		
	CtrS	Ct. 0 = 3rd Party	
		Ct. 1 = Wall Control (default)	
		Ct. 2 = Basic BMS	
		Ct. 3 = Wall Control + Basic BMS	
		Ct. 4 = Advanced BMS	
	iduS	FP1 = IDU Fan Low PWM setting	
		FP2 = IDU Fan Med PWM setting	
		FP3 = IDU Fan High PWM setting	
		Fr1 = IDU Fan Low RPM setting	
		Fr2 = IDU Fan Med RPM setting	
		Fr3 = IDU Fan High RPM setting	
		FPd = IDU Fan Defrost PWM setting	
		FPc = IDU Reduced Airflow PWM setting	
		FiL = IDU Fan Filter Hours setting	
		Econ = IDU Econ 0-10V Output setting	
	FnSE = Indoor Fan Setting		
	SoFt	no = Soft Start not enabled (default)	
		YES = Soft Start enabled	
	run	no = Indoor Fan and Compressor (default)	
		YES = Compressor only	
	odFS	Pc = Pressure control	
		tc = Temperature control	
		CrS = Cooling rated speed.	
		CHS = Cooling max. speed.	
		CtrS = Temp. restricted speed.	
		Crt1 = Cooling restricted temp.	
		Crt2 = Cooling restricted temp.	
		Crt3 = Cooling restricted temp.	
		HrS = Heating rated speed.	
		HHS = Heating max. speed.	
		HtrS = Heating temp. restricted speed.	
		Hrt1 = Heating restricted temp.	
		Hrt2 = Heating restricted temp.	
Hrt3 = Heating restricted temp.			
qS		CCS = Cooling compressor speed	
	HCS = Heating compressor speed		
	CCt = Cooling mode critical temp condition		
	Hct = Heating mode critical temp condition		

EEU	SEEU = Single EEV
	dEEU = Double EEV
EEUt	tE1 = UKV Type
	tE2 = UKV-SE Type (default)

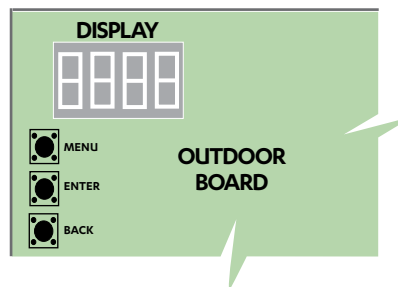

MENU

Scroll through the items at the same menu level. Increment the value being set.

ENTER

Go into the selected menu. Lock in selected value.

BACK

Go back to the parent menu. Press and hold to go back to main menu.

* Family and Capacity are the representative values only and may vary depend on the model purchased as seen below table. **Do not change setting.**

Model		CRS10AS	CRS13AS	CRS15AS	CRS17AS	CRS13AT	CRS15AT	CRS17AT	CRS20AT	CRS23AT
Family	Family Name	Capacity (kW)								
8	Single Phase	10	13	15	17	-	-	-	-	-
11	Three Phase	-	-	-	-	13	15	17	20	23

Configuring Compressor and Capacity(cnFg)

Configure the compressor type and capacity. The unit is factory configured. **Do not change this setting.**

Configuring Control Source (CtrS)

This commissioning is applicable for BMS and third party control.

Configurable settings are as follows:

Third Party Control

The unit can be controlled by non-ActronAir wall control. To do this, **CtrS** on the Outdoor Board has to be set to **Ct. 0**. For connection details, see the wiring diagram supplied with the outdoor unit.

Wall Control

ActronAir offers NEO, LR7-1 and LC7-2, wall controls that can control the available features and maximise the function and operation of the air conditioner. To do this, **CtrS** on the Outdoor Board must be set to **Ct. 1**.

Basic BMS

The unit can be connected to a network through a BMS card (ICUNO-MOD). This allows the unit to be operated in the same way the as the NEO, LR7-1 and LC7-2 does. To do this, **CtrS** on the Outdoor Board must be set to **Ct. 2**.

Wall Control + Basic BMS

The unit can be connected to a network (Basic BMS) and at the same time be controlled using the NEO, LR7-1 or LC7-2 controller. Priority will be given to the most recent command. To do this, **CtrS** on the Outdoor Board must be set to **Ct. 3**.

Advanced BMS

The unit can be connected for system that requires customised functions not included in the existing software or logic in the Outdoor Board but still retaining the safety logic. To do this, **CtrS** on the Outdoor Board must be set to **Ct. 4**.

Auto Fan Function

Auto fan function can only be commissioned by ActronAir wall control such as NEO, LR7-1 and LC7-2.

Third Party Control Input (Indoor and/or Outdoor Board)

This option allows Fan, Compressor and Reversing Valve to be controlled by a Third Party Control. There are two ways on how the Indoor Fan may be controlled, using 0-10V Analogue Input or Fixed Indoor Fan Speed.

Refer to InZone Board for these models.

NOTE

- Demand Response Management (DRM) is not available if Third Party Control Option is used.
- Ensure control source has been configured for Control Mode 0.

0-10V Analogue Input for Compressor and Indoor Fan

Indoor Fan Connection (Indoor Board)



Input (DC)	Output	Fan Status
0.0V to 0.99 V	0%	Off
1.0V to 1.49 V	0 or 20%	Off or On
1.5V to 9.5 V	20% to 100%	On
9.5V to 10 V	100%	On

Compressor and Reversing Valve Connection (Outdoor Board)

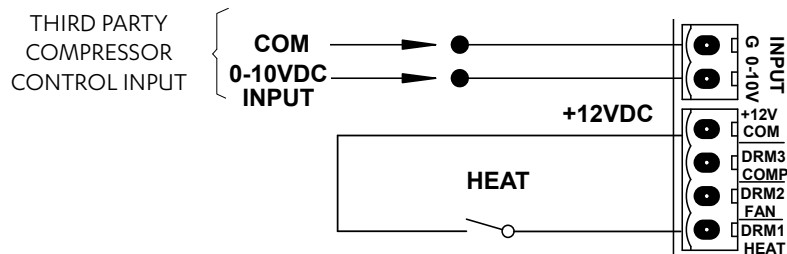

Input (DC)	Output	Compressor Status
0 - 0.99 V	0%	Off
1 - 1.49 V	0 or 20%	Off/On (hysteresis)
1.5 - 9.5 V	20% to 100%	On
9.5 - 10 V	100%	On

NOTES

- As the compressor turns ON and the Indoor fan signal is not available then indoor fan will start to run on medium PWM speed.
- Indoor fan low and high PWM limits depends upon the model.
- The Voltage can be linearly interpolated using the above table to determine the desired PWM or unit output.

0-10V Analogue Input for Compressor with Fixed Indoor Fan Speed

This feature allows for the Indoor Fan to be controlled externally (ON/OFF only).

Fan, Compressor and Reversing Valve Connection (Outdoor Board)

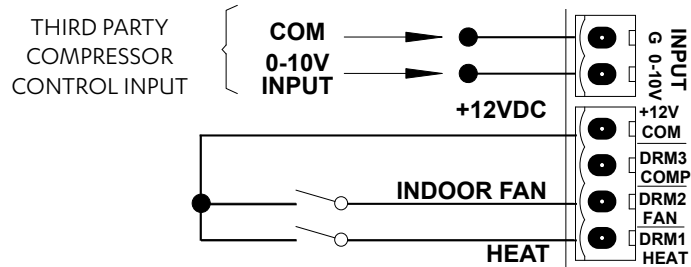

NOTES

- As the compressor turns ON and the Indoor fan signal is not available then indoor fan will start to run on medium PWM speed.
- Indoor fan operation when fan signal is available:
 - Compressor ON : Indoor fan will run on medium speed.
 - Compressor OFF : Indoor fan will run on reduce airflow operation.

Input for Fixed Compressor with Fixed Indoor Fan Speed

This feature allows for both Compressor and Indoor Fan to be controlled externally (ON/OFF only).

Fan, Compressor and Reversing Valve Connection (Outdoor Board)

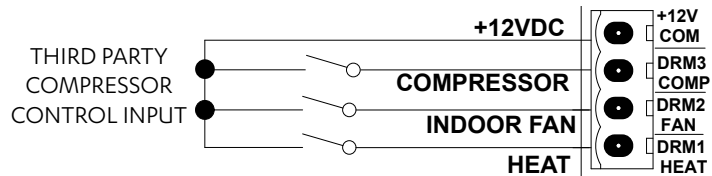

NOTES

- As the compressor turns ON and the Indoor fan signal is not available then indoor fan will start to run on medium PWM speed.
- Indoor fan operation when fan signal is available:
 - Compressor ON : Indoor fan will run on medium speed.
 - Compressor OFF : Indoor fan will run on reduce airflow operation.
- Compressor turns on with 100% speed request.
- Although the compressor will have 100% speed request, the speed may vary depending on compressor safety requirements.

0-10V Analogue Input for Indoor Fan with Fixed Speed Compressor

This feature allows for the compressor to be controlled externally (ON/OFF only).

Indoor Fan Connection (Indoor Board)



Input (DC)	Output	Fan Status
0.0 V to 0.99 V	0%	Off
1.0 V to 1.49 V	0 or 20%	Off or On
1.5 V to 9.5 V	20% to 100%	On
9.5 V to 10 V	100%	On

Fan, Compressor and Reversing Valve Connection (Outdoor Board)

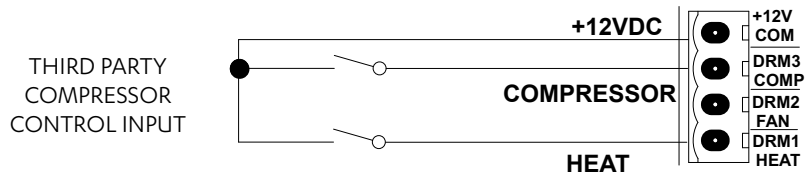

NOTES

- As the compressor turns ON and the Indoor fan signal is not available then indoor fan will start to run on medium PWM speed.
- If the compressor turn ON, during reduced fan operation, the controller will increase the fan speed to the "low PWM fan limit" if it is running less than the low PWM Limits.
- Indoor fan low and high PWM limits depends upon the model.
- The Voltage can be linearly interpolated using the above table to determine the desired PWM or unit output.
- Compressor turns on with 100% speed request.

Run and Fault Indication Output (Outdoor Board)

To activate, the unit must be wired as illustrated below. If required, a fault output connection terminal is also available to show any error/fault with the a/c system. RUN/FAULT relay outputs (230VAC/5A MAX) connection.

Run Indication

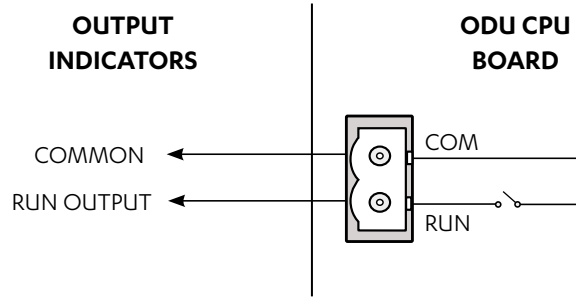

Run Output is configurable to indicate that the unit is running. There are two configurations in which this can be set:

- Either the compressor or the Indoor Fan only is running
- Only Compressor is running.

By default, this is set to turn on when either indoor fan or compressor is operating. To set up to compressor run indication only, in OD Board Menu follow below steps.

1. Using the **MENU** and the **ENTER** Buttons on the outdoor PCB, navigate to **Set** (Settings) → **run** (Unit Operation Indicator Settings).
2. If required, press **MENU** to navigate to **YES**.

Fault Indication

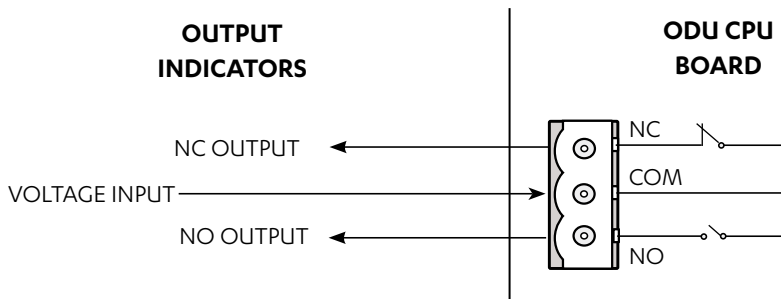

To indicate any system fault, outdoor controller will provide a signal through the Fault Indication relay. An installer can use either NC or NO output as per their requirements.

Remote On/Off

To activate, the unit must be wired as illustrated below. This will enable unit to be turned ON and OFF from the Outdoor board.

NOTES

The system must be operating in Wall Controller only (control mode 1) or BMS + Wall Controller (control mode 3) for this function to work.

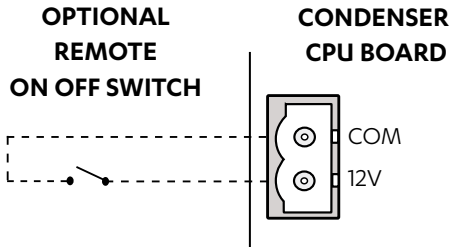

Turning the system On and Off by remote method

Turning the system On	Status 1: The system is Off and the remote switch/relay has been left in the open position. 1. Close remote switch/relay. 2. System will turn on/off in approximately in 30 seconds.
	Status 2: The system is Off and the remote switch/relay has been left in the closed position. 1. Open remote switch/relay for a minimum of 5 seconds. 2. Close remote switch/relay. 3. System will turn on/off in approximately in 30 seconds.
Turning the system Off	Status 3: The system is On and the remote switch/relay has been left in the closed position. 1. Open remote switch/relay. 2. System will turn on/off in approximately in 30 seconds.
	Status 4: The system is On and the remote switch/relay has been left in the open position. 1. Close remote switch/relay for a minimum of 5 seconds. 2. Open remote switch/relay. 3. System will turn on/off in approximately in 30 seconds.

Indoor Fan Commissioning

EVA10AS

FAN DATA*																
AIRFLOW (l/s)	EXTERNAL STATIC PRESSURE (Pa)															
	25		50		75		100		125		150		175		200	
	% SPD.	W	% SPD.	W	% SPD.	W	% SPD.	W	% SPD.	W	% SPD.	W	% SPD.	W	% SPD.	W
400			35	451	38	537	40	595	42	664	44	733	47	836	49	905
425	35	422	38	501	41	587	43	651	46	753	48	830	50	907	52	907
450	39	500	42	581	45	667	47	739	49	810	51	890	53	976	55	1063
475	43	578	46	662	48	728	51	833	53	912	55	990	57	1069	59	1147
500	46	630	50	743	52	815	55	924	57	1019	59	1114	61	1183	MOTOR / BLOWER LIMIT	
525	50	710	53	805	56	912	58	997	60	1082	63	1212	65	1299		
550	54	802	57	903	60	1012	62	1103	64	1195	67	1301	73	1413		
575	58	898	61	1002	64	1120	67	1239	69	1318	75	1318				
600	62	994	66	1139	68	1222	72	1356	80	1483						

NOTES

* Above Fan Data table is only applicable only to Third Party Controller

W = Indoor Fan Power, Watts

PWM = Pulse Width Modulation Setting, 50% PWM (Adjustable through the LR7-1, LC7-2, NEO or Outdoor Board).

Default Fan Speed Value at 100 Pa	
Speed	Default PWM (adjustable)
High PWM (%)	72
Medium PWM (%)	55
Low PWM (%)	40

Indoor Fan PWM Limits	
Maximum PWM Limit (%)	99
Minimum PWM Limit (%)	35

EVA10AS : Three Speed Application Fan Curve

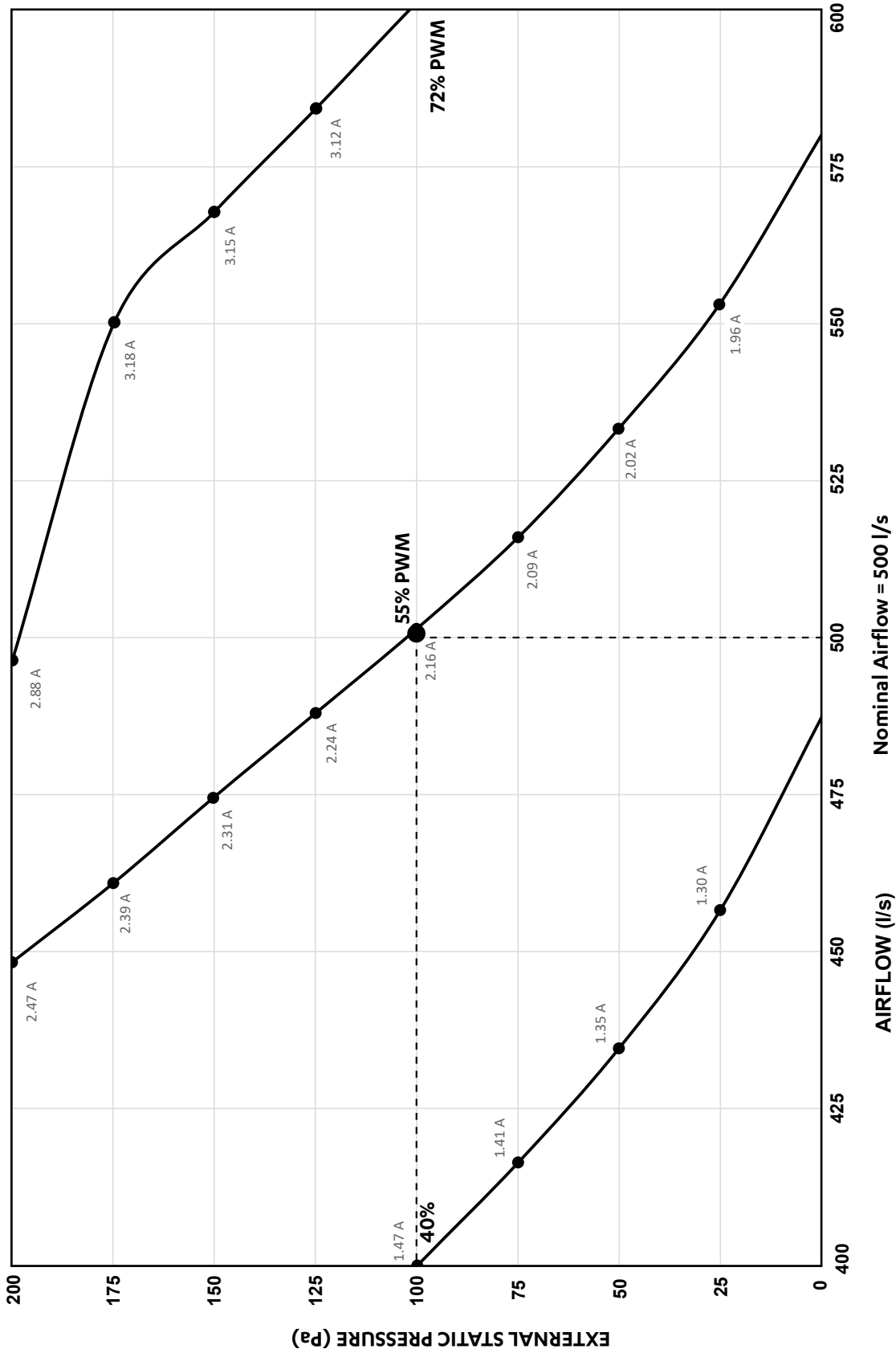

EVA10AS : Third Party Application Fan Curve

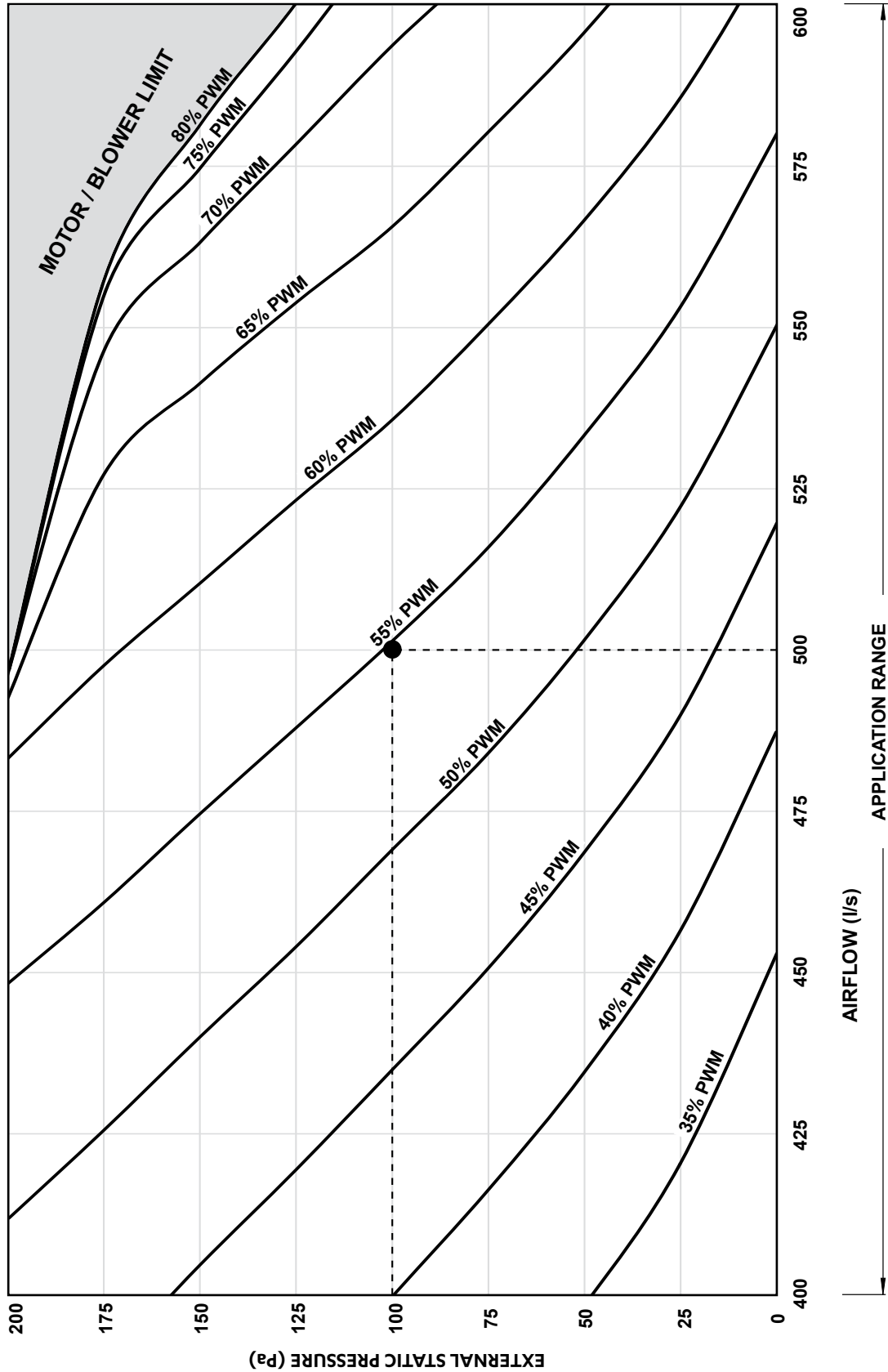

NOTE

Fan Performance Data and Fan Curve shown is at dry coil and with no air filters installed. Consider external static pressure drop specific to your design requirements. Airflow should be reduced with respect to the moisture content in the air. Please review filter manufacturer for application. 2.5 m/s face velocity point will occur outside the application range.

EVA13AS / EFA13AS

FAN DATA*										
AIRFLOW (l/s)	EXTERNAL STATIC PRESSURE (Pa)									
	50		100		150		200		250	
	% PWM	W	% PWM	W	% PWM	W	% PWM	W	% PWM	W
520	32	120	37	167	43	226	48	283	53	344
550	34	132	40	188	46	249	50	299	56	372
575	36	142	42	197	48	263	53	323	59	393
600	38	152	45	215	50	273	56	344	61	404
625	41	170	47	226	53	294	58	366	62	430
650	44	186	50	246	56	317	60	379	64	441
675	46	195	52	257	58	332	62	392	67	471
700	49	214	55	278	60	345	65	418	71	500
725	52	234	57	290	63	370	69	454	90	540
750	54	241	60	314	66	393	72	470	MOTOR / BLOWER LIMIT	
775	57	262	63	336	69	419	77	500		
780	58	266	64	340	70	423	79	507		

NOTES

* Above Fan Data table is only applicable only to Third Party Controller

W = Indoor Fan Power, Watts

PWM = Pulse Width Modulation Setting, 50% PWM (Adjustable through the LR7-1, LC7-2, NEO or Outdoor Board).

Default Fan Speed Value at 100 Pa	
Speed	Default PWM (adjustable)
High PWM (%)	64
Medium PWM (%)	50
Low PWM (%)	40

Indoor Fan PWM Limits	
Maximum PWM Limit (%)	99
Minimum PWM Limit (%)	30

EVA13AS / EFA13AS : Three Speed Application Fan Curve

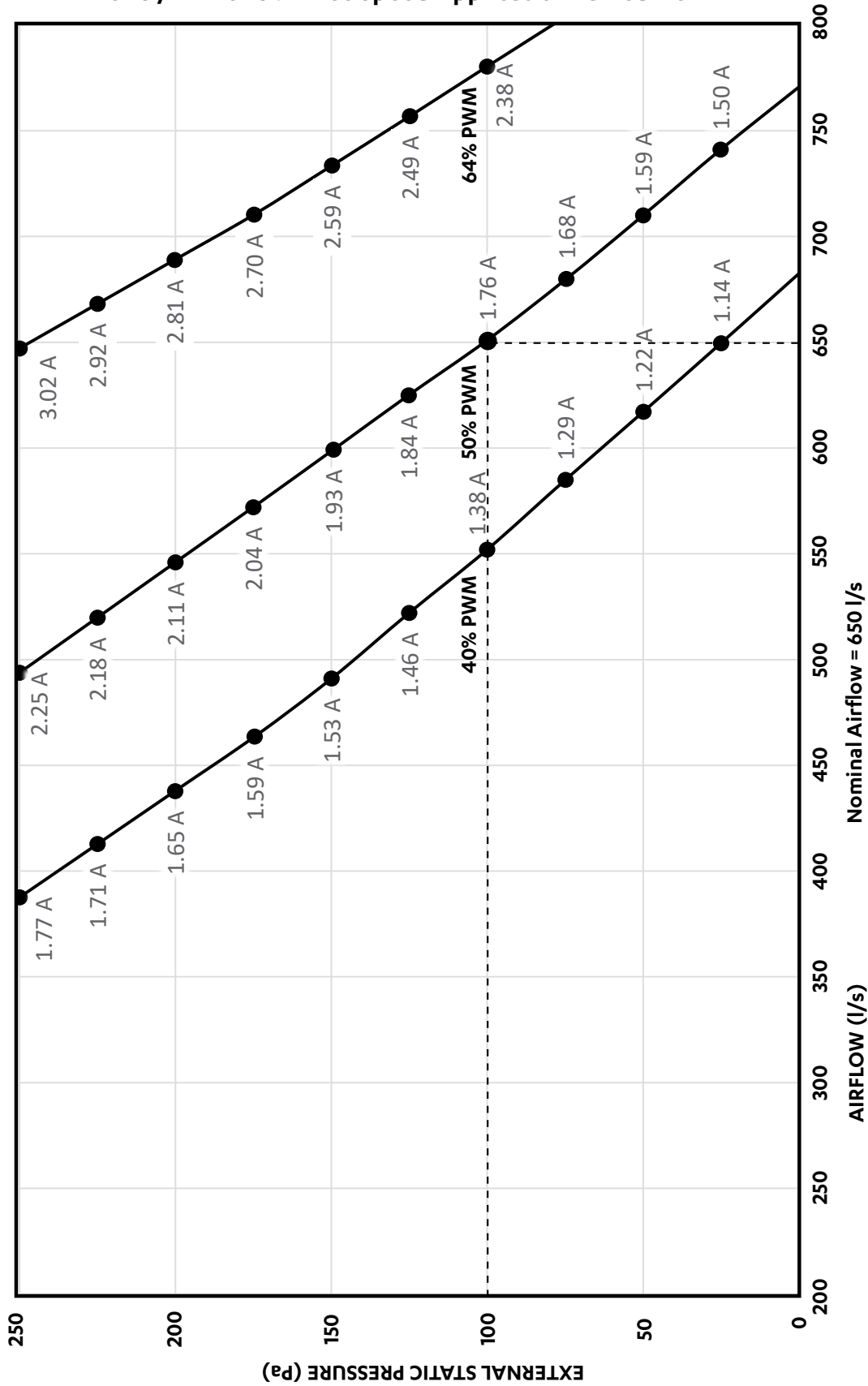

EVA13AS / EFA13AS : Third Party Application Fan Curve

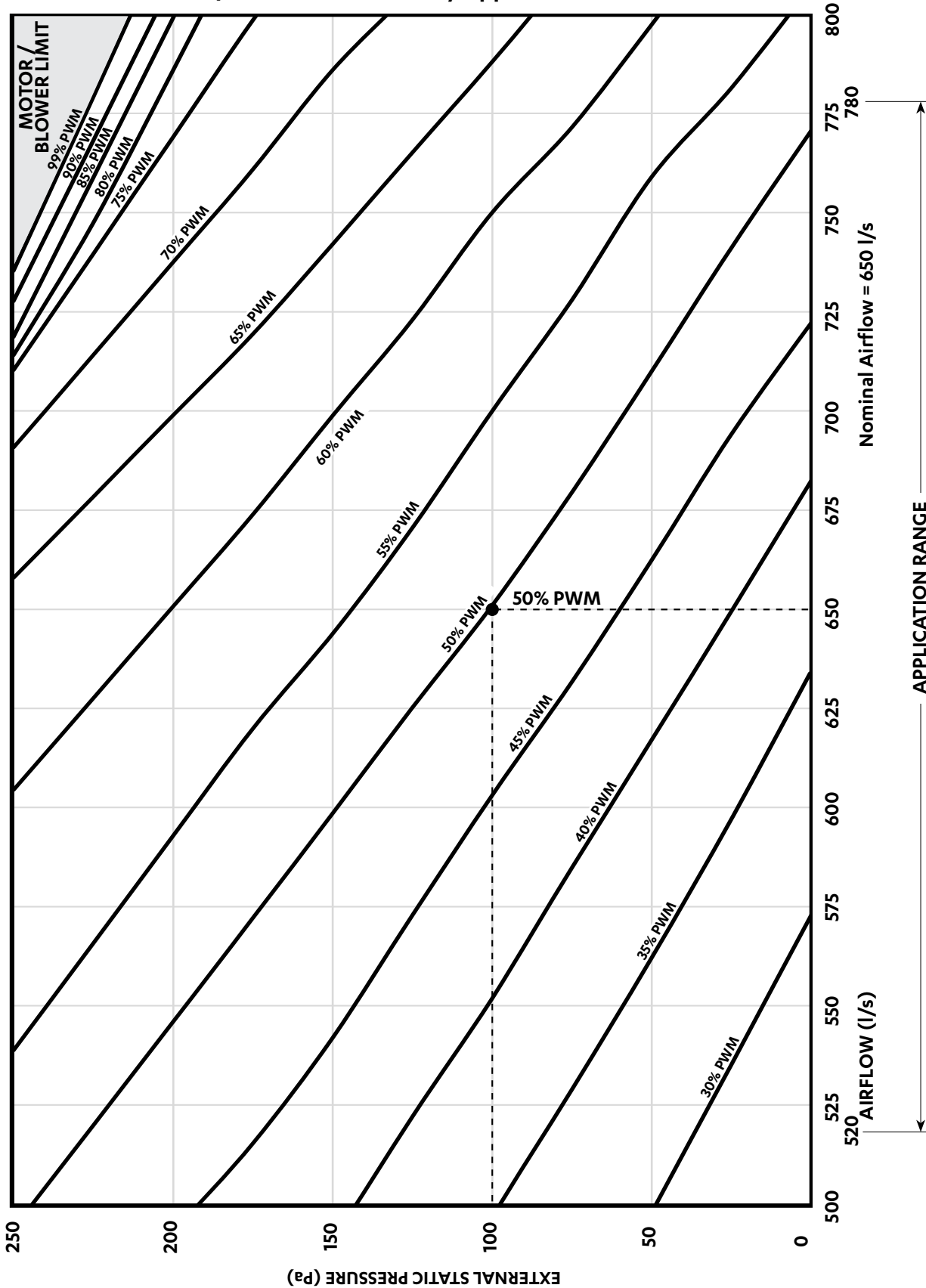

NOTE

Fan Performance Data and Fan Curve shown is at dry coil and with no air filters installed. Consider external static pressure drop specific to your design requirements. Airflow should be reduced with respect to the moisture content in the air. Please review filter manufacturer for application. 2.5 m/s face velocity point will occur outside the application range.

EVA15AS / EFA15AS

FAN DATA*

AIRFLOW (l/s)	EXTERNAL STATIC PRESSURE (Pa)									
	50		100		150		200		250	
	% PWM	W	% PWM	W	% PWM	W	% PWM	W	% PWM	W
620	41	164	48	224	55	288	62	376	67	458
650	45	180	52	244	58	310	63	386	71	480
675	48	196	55	261	61	336	65	411	75	501
700	51	211	58	280	63	357	67	419	96	545
725	55	238	61	306	64	360	69	434	MOTOR / BLOWER LIMIT	
750	58	255	62	309	67	390	72	456		
770	60	261	64	324	69	396	75	479		
775	60	263	64	327	69	397	76	485		
800	62	282	67	352	73	432	80	510		
825	64	297	70	371	76	452	87	539		
850	67	321	74	407	80	480	MOTOR / BLOWER LIMIT			
875	71	352	78	437	84	511				
900	75	382	81	456	90	547				
920	77	397	84	486						

NOTES

* Above Fan Data table is only applicable only to Third Party Controller

W = Indoor Fan Power, Watts

PWM = Pulse Width Modulation Setting, 64% PWM (Adjustable through the LR7-1, LC7-2, NEO or Outdoor Board).

Default Fan Speed Value at 100 Pa	
Speed	Default PWM (adjustable)
High PWM (%)	78
Medium PWM (%)	64
Low PWM (%)	52

Indoor Fan PWM Limits	
High PWM Limit (%)	99
Low PWM Limit (%)	41

EVA15AS / EFA15AS : Three Speed Application Fan Curve

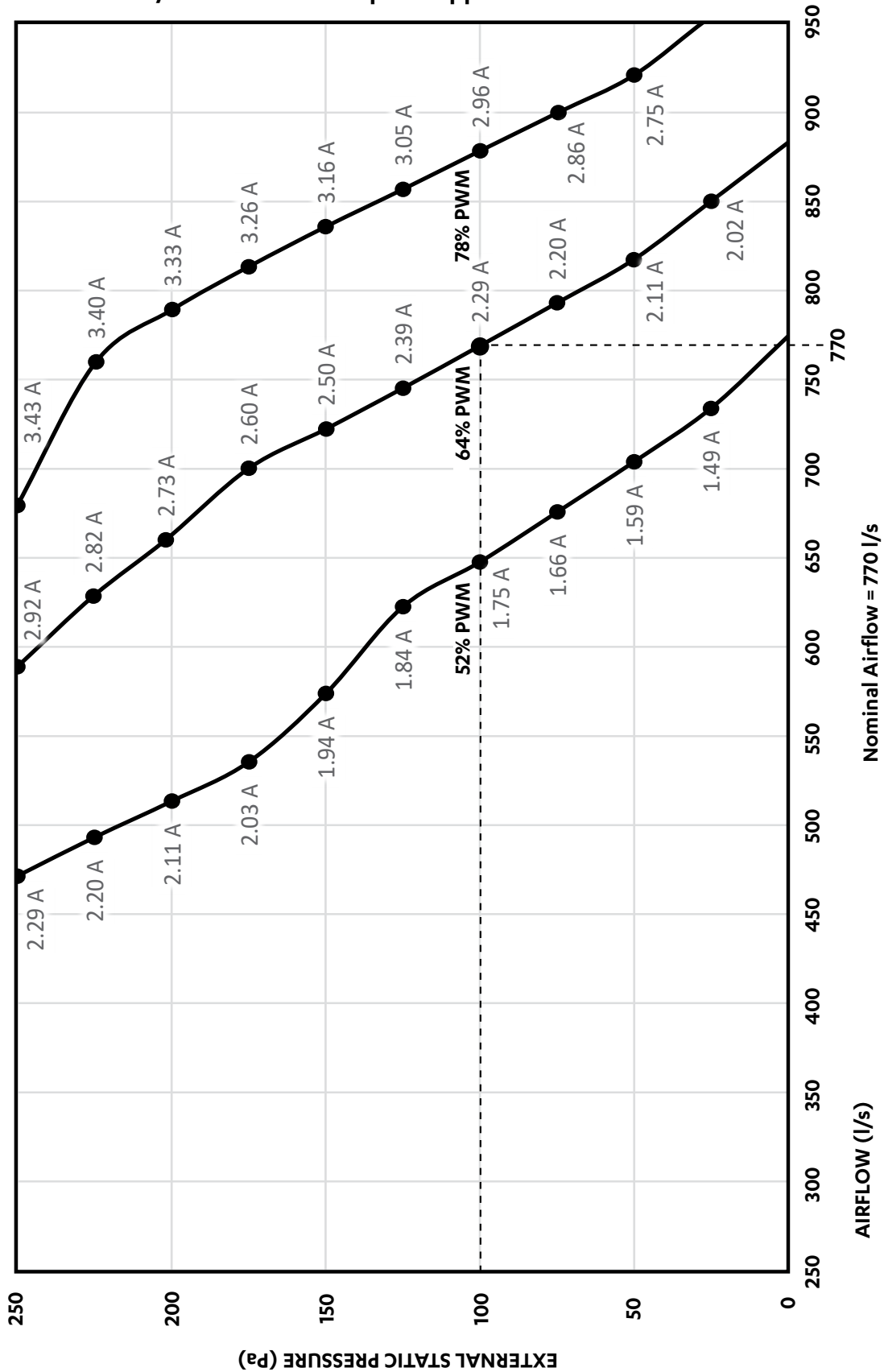

EVA15AS / EFA15AS : Third Party Application Fan Curve

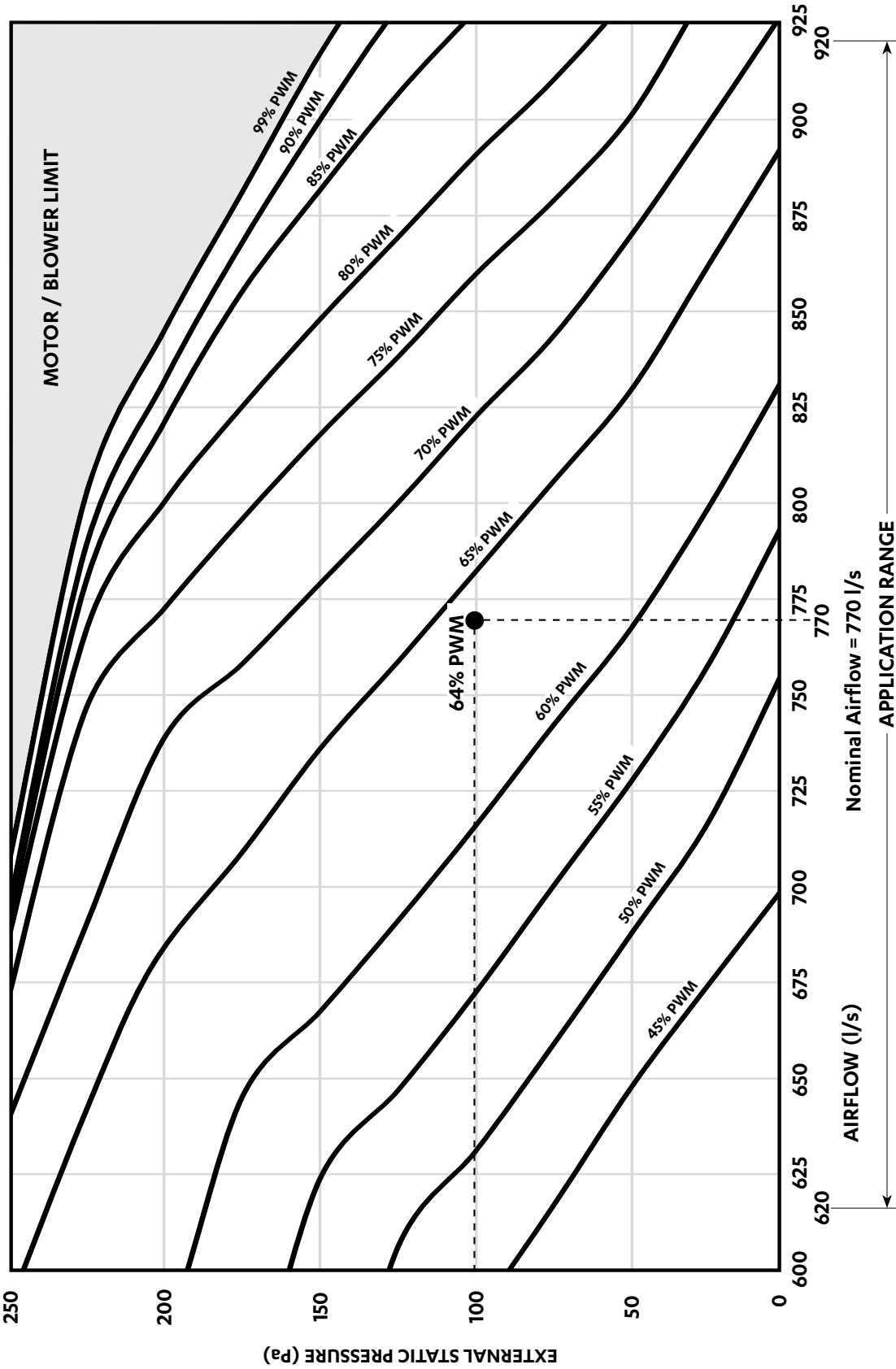

NOTE

Fan Performance Data and Fan Curve shown is at dry coil and with no air filters installed. Consider external static pressure drop specific to your design requirements. Airflow should be reduced with respect to the moisture content in the air. Please review filter manufacturer for application. 2.5 m/s face velocity point will occur outside the application range.

EVA17AS / EFA17AS

FAN DATA*

AIRFLOW (l/s)	EXTERNAL STATIC PRESSURE (Pa)									
	50		100		150		200		250	
	% PWM	W	% PWM	W	% PWM	W	% PWM	W	% PWM	W
710	46	185	52	247	58	317	64	397	70	468
725	48	196	54	259	60	330	66	411	72	485
750	50	202	57	279	63	355	69	433	76	502
775	53	220	60	299	66	378	72	453	90	534
800	56	237	62	308	69	401	75	477	MOTOR / BLOWER LIMIT	
825	59	255	65	328	72	422	80	503		
850	62	273	68	349	75	444	87	534		
875	65	293	72	382	79	471	99	555		
890	67	303	73	395	81	485				
900	68	310	75	403	83	495				
925	71	328	78	419	88	523				
950	75	360	82	446	95	552				
975	78	377	87	480						
1000	82	404	92	509						
1025	87	438								
1050	92	467								
1060	95	487								

NOTES

* Above Fan Data table is only applicable only to Third Party Controller

W = Indoor Fan Power, Watts

PWM = Pulse Width Modulation Setting, 73% PWM (Adjustable through the LR7-1, LC7-2, NEO or Outdoor Board).

Default Fan Speed Value at 100 Pa	
Speed	Default PWM (adjustable)
High PWM (%)	99
Medium PWM (%)	73
Low PWM (%)	57

Indoor Fan PWM Limits	
High PWM Limit (%)	99
Low PWM Limit (%)	46

EVA17AS / EFA17AS : Three Speed Application Fan Curve

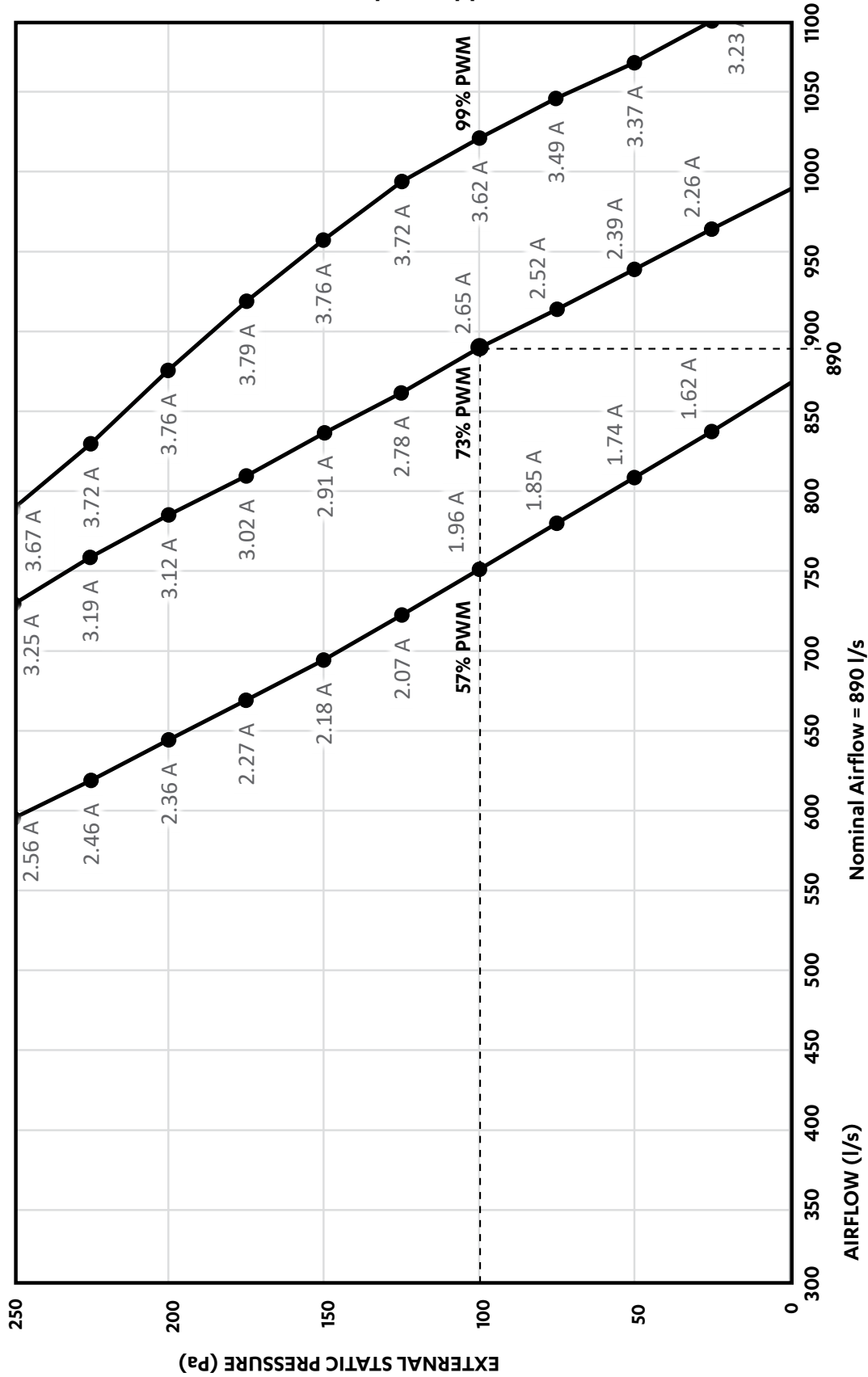

EVA17AS / EFA17AS : Third Party Application Fan Curve

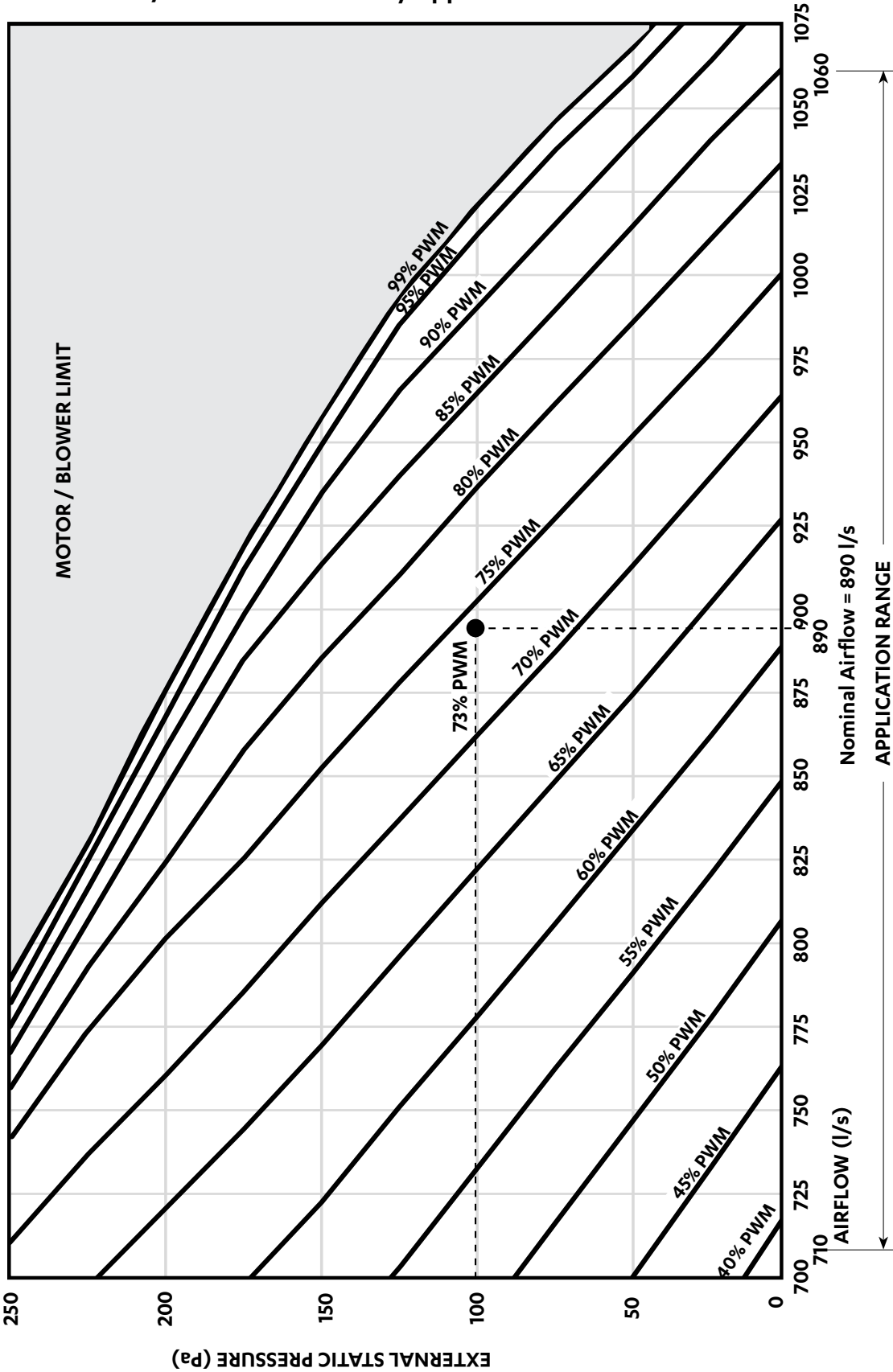

NOTE

Fan Performance Data and Fan Curve shown is at dry coil and with no air filters installed. Consider external static pressure drop specific to your design requirements. Airflow should be reduced with respect to the moisture content in the air. Please review filter manufacturer for application. 2.5 m/s face velocity point will occur outside the application range.

EVA20AS / EFA20AS

FAN DATA*

AIRFLOW (l/s)	EXTERNAL STATIC PRESSURE (Pa)											
	50		100		150		200		250		300	
	% PWM	W	% PWM	W	% PWM	W	% PWM	W	% PWM	W	% PWM	W
850	44	732	50	956	57	1241	63	1509	69	1770	88	2103
875	46	777	52	1004	59	1293	65	1567	72	1857	91	2165
900	480	823	55	1091	61	1347	67	1626	74	1920	94	2235
925	50	865	57	1143	63	1402	70	1731	78	2017	97	2280
950	52	914	59	1192	65	1456	72	1783	81	2099	MOTOR / BLOWER LIMIT	
975	54	961	61	1243	68	1557	74	1842	84	2170		
1000	57	1047	64	1339	70	1609	77	1932	88	2258		
1025	59	1095	66	1391	73	1711	79	1995	91	2336		
1050	61	1143	68	1444	75	1760	82	2089	95	2433		
1075	64	1232	70	1497	78	1871	85	2212	99	2449		
1100	66	1281	73	1597	80	1928	88	2293	MOTOR / BLOWER LIMIT			
1125	68	1333	76	1698	83	2033	90	2389				
1150	71	1427	78	1746	85	2088	93	2462				
1175	74	1522	81	1843	88	2198	95	2563				
1200	76	1570	84	1943	91	2310	99	2511				
1225	79	1665	87	2049	94	2416	MOTOR / BLOWER LIMIT					
1250	82	1759	89	2104	96	2412						

NOTES

* Above Fan Data table is only applicable only to Third Party Controller

W = Indoor Fan Power, Watts

PWM = Pulse Width Modulation Setting, 68% PWM (Adjustable through the LR7-1, LC7-2, NEO or Outdoor Board).

Default Fan Speed Value at 100 Pa	
Speed	Default PWM (adjustable)
High PWM (%)	50
Medium PWM (%)	68
Low PWM (%)	89

Indoor Fan PWM Limits	
High PWM Limit (%)	99
Low PWM Limit (%)	44

EVA20AS / EFA20AS : Three Speed Application Fan Curve

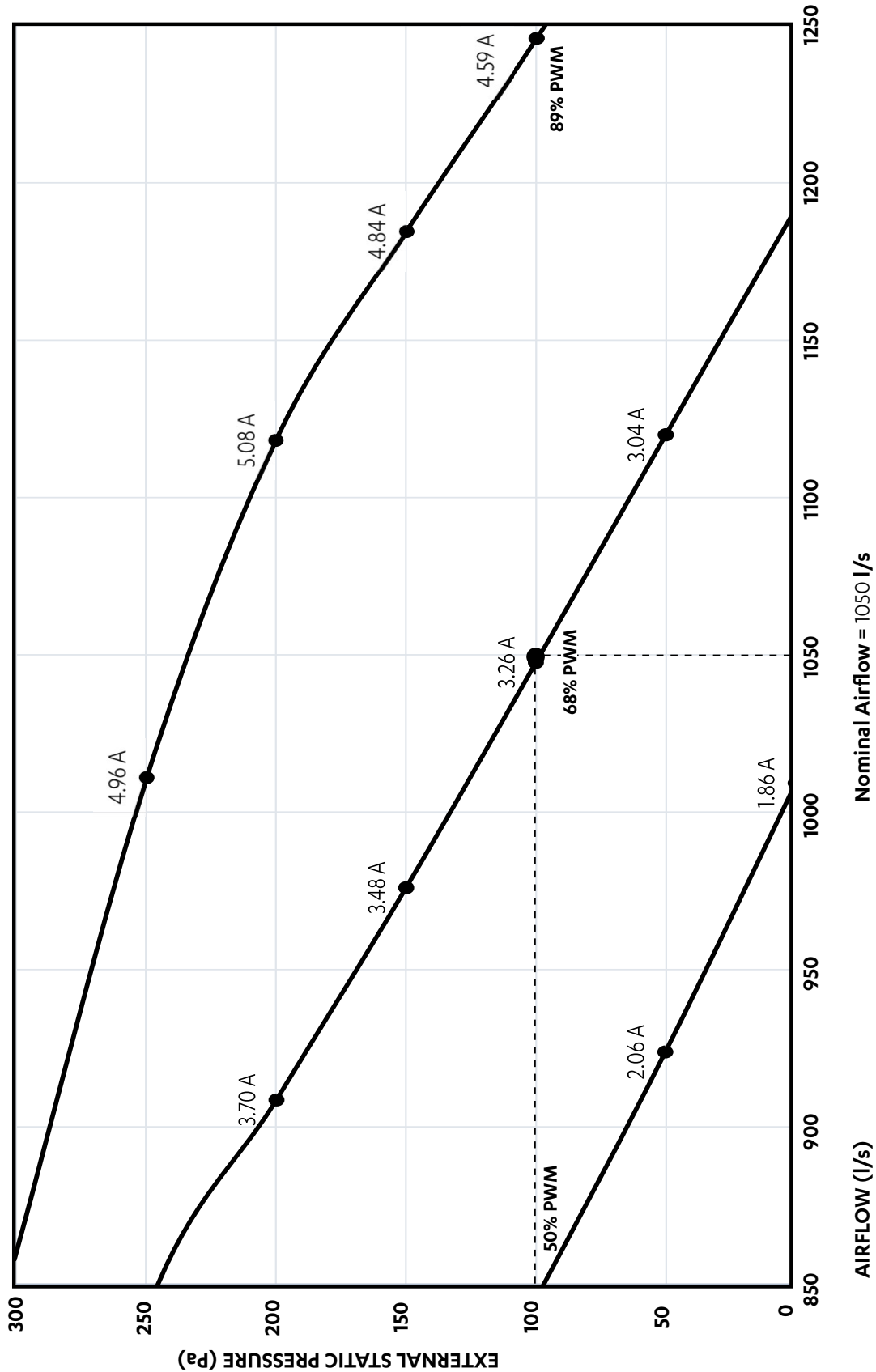

EVA20AS / EFA20AS : Third Party Application Fan Curve

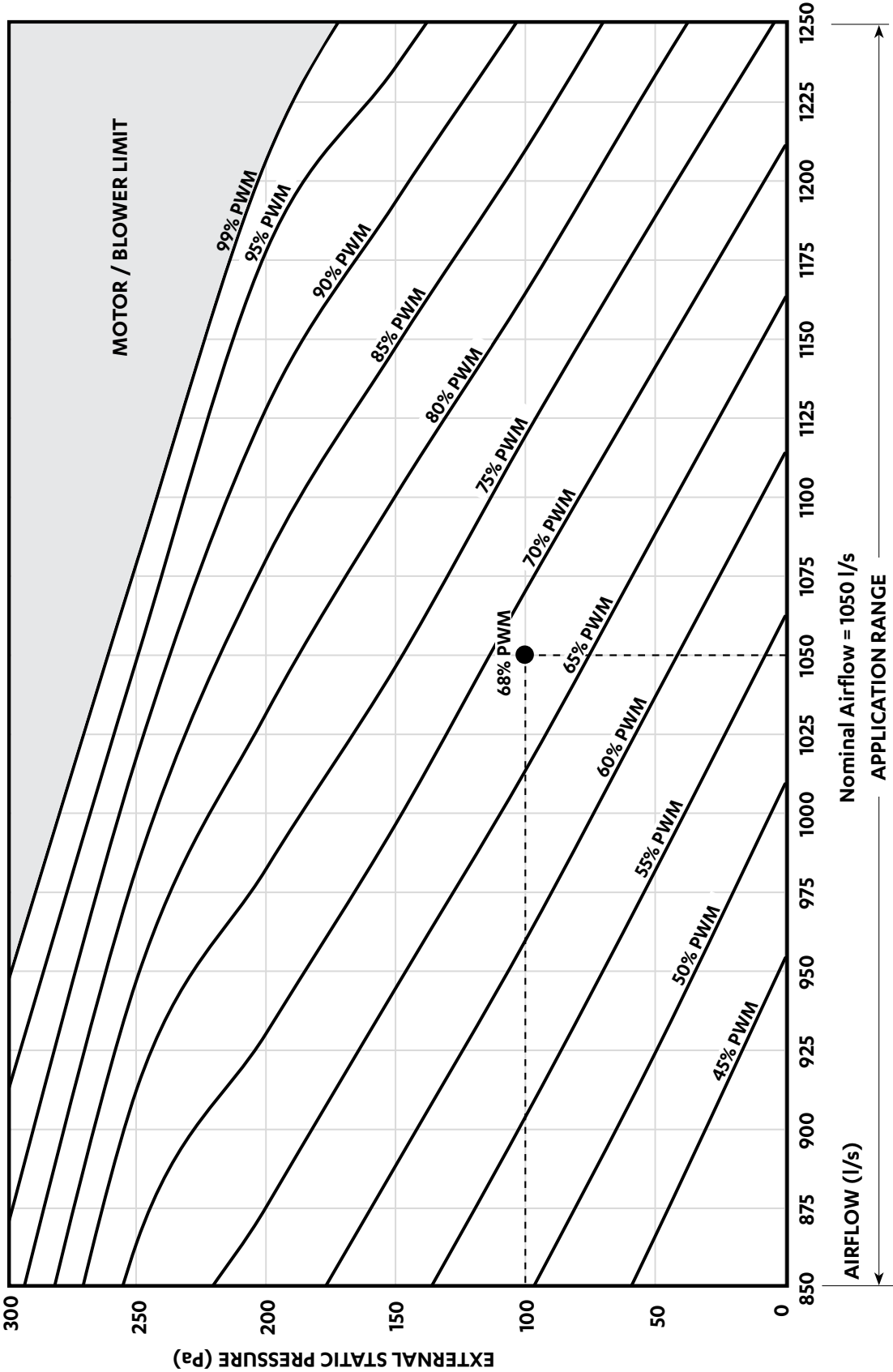

NOTE

Fan Performance Data and Fan Curve shown is at dry coil and with no air filters installed. Consider external static pressure drop specific to your design requirements. Airflow should be reduced with respect to the moisture content in the air. Please review filter manufacturer for application. 2.5 m/s face velocity point will occur outside the application range.

EVA23AS / EFA23AS

FAN DATA*

AIRFLOW (l/s)	EXTERNAL STATIC PRESSURE (Pa)											
	50		100		150		200		250		300	
	% PWM	W	% PWM	W	% PWM	W	% PWM	W	% PWM	W	% PWM	W
950	41	876	45	1091	49	1332	53	1588	58	1835	73	2114
1000	44	956	49	1237	53	1487	57	1750	62	1999	78	2269
1050	48	1092	52	1324	57	1642	61	1897	67	2159	84	2447
1100	52	1230	56	1469	61	1795	65	2067	73	2332	90	2634
1150	56	1367	60	1613	65	1948	69	2206	80	2539	97	2799
1200	60	1506	65	1830	69	2110	74	2418	87	2744	MOTOR / BLOWER LIMIT	
1250	64	1650	69	1983	73	2266	79	2631	94	2954		
1300	69	1861	74	2202	78	2494	84	2820				
1350	74	2071	78	2352	83	2700	92	3073				
1400	78	2219	83	2577	89	2977						
1450	83	2434	89	2870	94	3202						

NOTES

* Above Fan Data table is only applicable only to Third Party Controller

W = Indoor Fan Power, Watts

PWM = Pulse Width Modulation Setting, 65% PWM (Adjustable through the LR7-1, LC7-2, NEO or Outdoor Board).

Default Fan Speed Value at 100 Pa	
Speed	Default PWM (adjustable)
High PWM (%)	45
Medium PWM (%)	65
Low PWM (%)	89

Indoor Fan PWM Limits	
High PWM Limit (%)	99
Low PWM Limit (%)	41

EVA23AS / EFA23AS : Three Speed Application Fan Curve

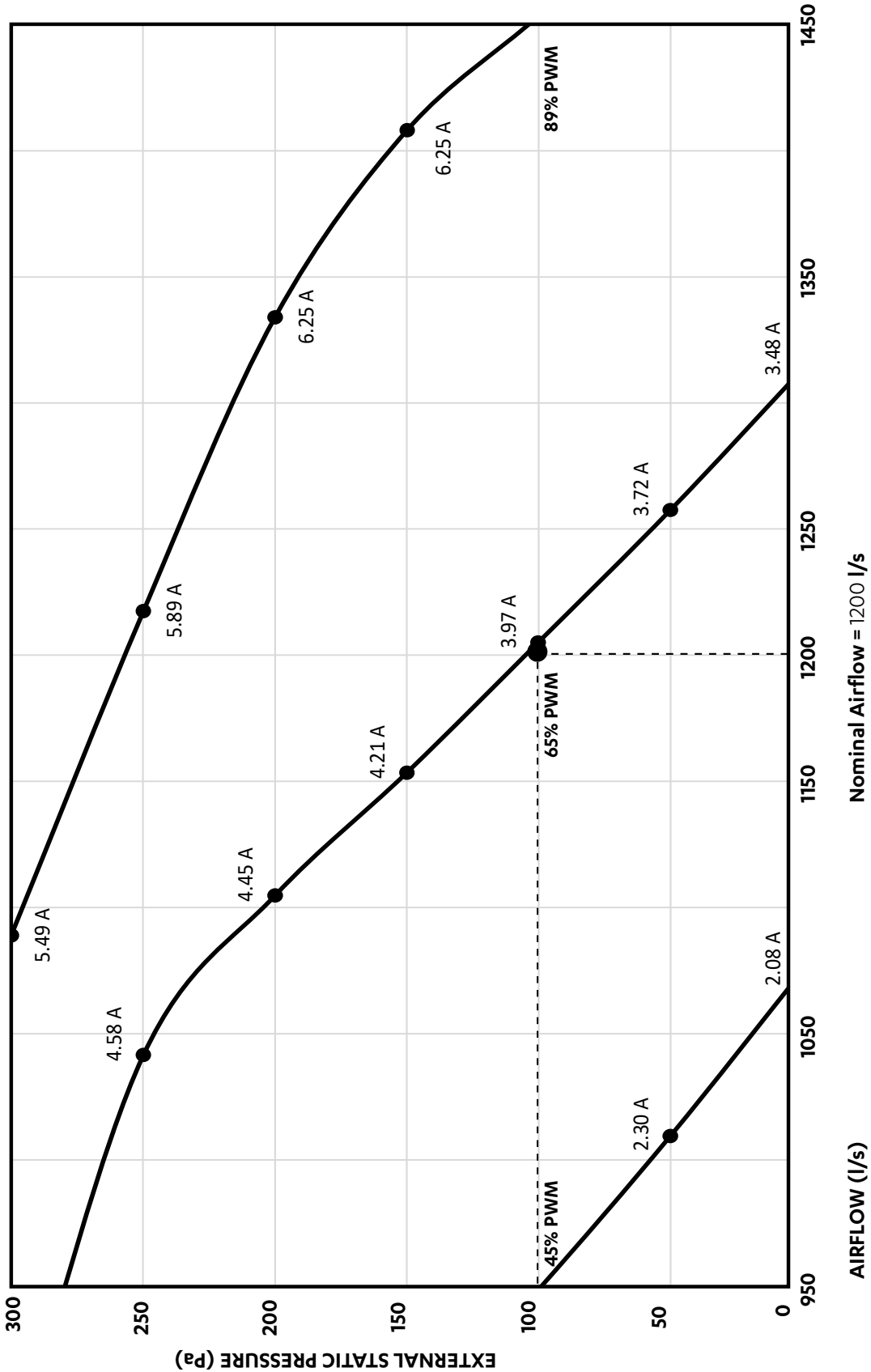

EVA23AS / EFA23AS : Third Party Application Fan Curve

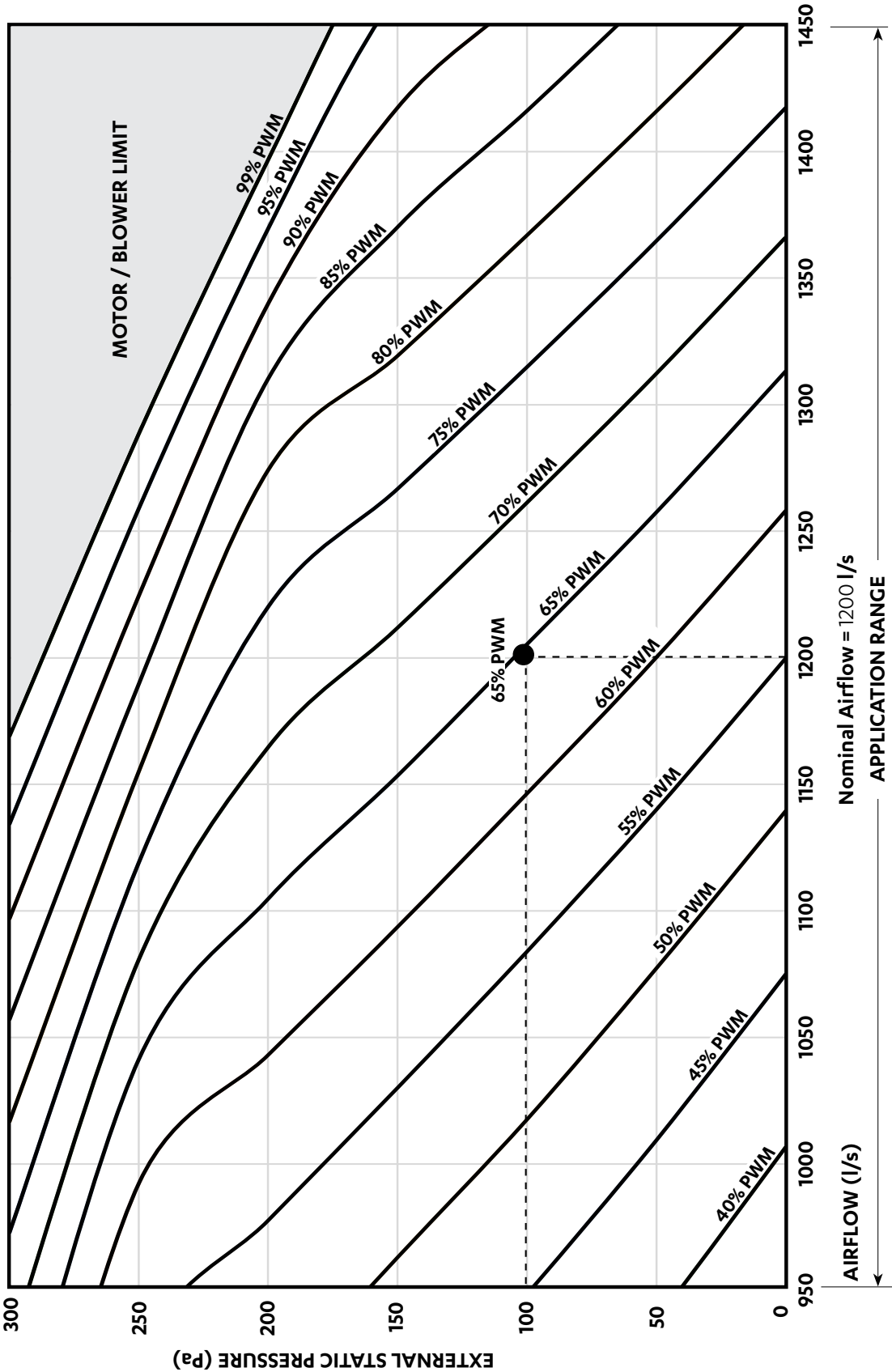

NOTE

Fan Performance Data and Fan Curve shown is at dry coil and with no air filters installed. Consider external static pressure drop specific to your design requirements. Airflow should be reduced with respect to the moisture content in the air. Please review filter manufacturer for application. 2.5 m/s face velocity point will occur outside the application range.

Refrigerant Charging

- The unit is supplied with factory charged refrigerant as stated in the Rating Label. The use of other material as a refrigerant may cause explosion and/or personal injury.
- Be aware of all the relevant regulations concerning the handling of refrigerant.
- The refrigeration system operates with Ester (VG74) oil.
- It is important to work with absolute cleanliness.
- Brazing must be done with the use of Nitrogen to avoid carbon deposits into the pipes.
- The system must be evacuated thoroughly to 500 microns (see evacuation procedure).
- Never allow refrigerant to vent into the atmosphere. It is an offence to release refrigerant in Australia.
- Always reclaim refrigerant using equipment and container dedicated for the refrigerant used in the system.
- Only qualified technicians are allowed to perform any work described in this guide.
- All work must be carried out in accordance with Australia and New Zealand refrigerant handling code of practice.

⚠ CAUTION

VG74 oil that rapidly absorbs moisture. The maximum time any system can be opened to atmosphere is 15 minutes. This unit is charged with R-32 refrigerant.

- This outdoor unit is designed to match only with an ActronAir indoor unit as specified in the Technical Selection Catalogue.
- R-32 refrigerant (CLASS A2L) is mildly flammable. Thoroughly read and understand the accompanying R-32 Safety Guide for installation and maintenance instructions.
- R-32 refrigerant is odorless if the refrigerant gas comes into contact with fire, it may emit a poisonous gas.
- Installation, service, maintenance, repairs and decommissioning of this unit must be performed by a licensed HVAC technician; qualified to handle R-32 refrigerant.
- Appliance shall be installed, operated and stored in a well ventilated area:
 - away from other potential continuously operating sources that known to cause ignition of R-32 refrigerant.
 - where the room size corresponds to the room area as specific for operation.
 - without continuously operating open flames (for example an operating gas appliance) and ignition sources (for example an operating electric heater).

REFRIGERANT CHARGE DETAILS (R-32)			
Model	Refrigerant Charge (g)	Model	Refrigerant Charge (g)
CRS10AS	2300	CRS13AT	3300
CRS13AS	3400	CRS15AT	3600
CRS15AS	3600	CRS17AT	4100
CRS17AS	4100	CRS20AT	5000
		CRS23AT	5400

Note: For installations over 40 m, additional 5ml of oil is required for every additional 5 meters.

Charging Method: Subcooling and Superheat

Parameters:

LLT = Liquid Line Temperature

SLT = Suction Line Temperature

SCT = Saturated Condensing Temperature

SST = Saturated Suction Temperature

Cooling and Heating Operation:

Adjust the refrigerant charge to obtain the correct super heat and sub-cool for optimal performance as follows:

1. Ensure that air filters are fitted and total system airflows are achieved. (Air filters are not supplied with the unit, it is the responsibility of the installing contractor to provide and fit adequate return air and fresh air filters).
2. Connect service gauges to the shut off valves.
3. Start the unit in cool mode ensuring that the compressor is in operation before taking service gauges reading. Allow the system to stabilise for next 15 - 30 minutes before recording.
4. Record the discharge pressure, suction pressure, liquid line temperature and suction line temperature for all the refrigeration circuits.

Discharge Pressure = _____ kPa

Suction Pressure = _____ kPa

Liquid Line Temperature (**LLT**) = _____ °C

Suction Line Temperature (**SLT**) = _____ °C

See Diagram Below:

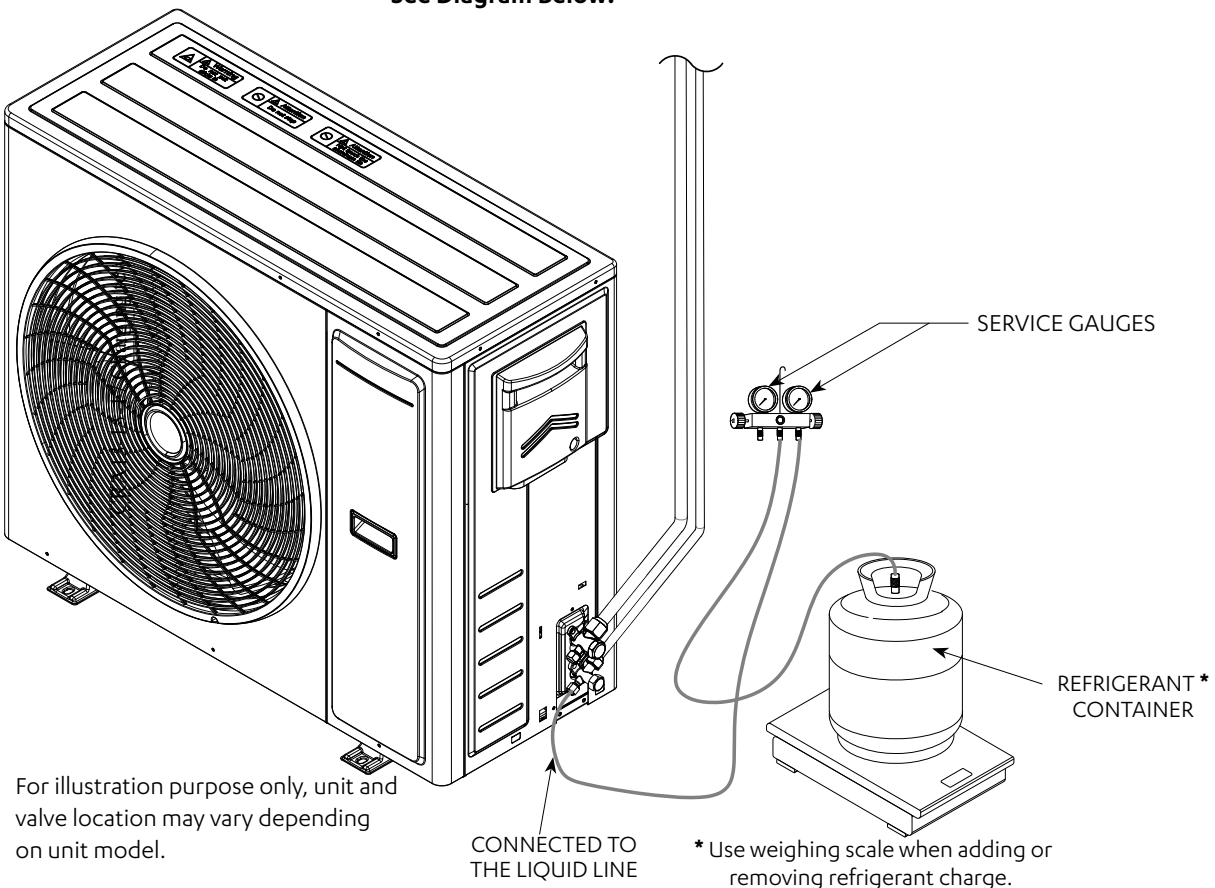

NOTES

- Accurate pressure and temperature measuring tools should be used to achieve satisfactory results.
- The sensors of thermocouple must be in good contact with the area being measured and must be insulated in order to obtain correct reading.

Checking for Subcooling

1. From the Pressure / Temperature Chart, record the corresponding Saturated Condensing Temperature (**SCT**) at the given discharge pressure.
2. Calculate the system subcooling using the formula below:

$$\text{Subcooling} = \text{SCT} - \text{LLT}$$

3. If subcooling is within the range (see charging table), there is no need to add/remove refrigerant.
 - If subcooling is lower than minimum, the system is undercharged, it is necessary to add refrigerant.
 - If subcooling is higher than maximum, the system is overcharged, it is necessary to remove refrigerant.

Allow the systems to stabilise (15 - 30 mins) and repeat the steps 1-3 until subcooling falls within the range specified in the Subcooling/Superheat Table below.

Checking for Superheat

Maintaining the correct superheat is important for ensuring the evaporator is achieving maximum capacity and avoiding excessive liquid refrigerant returning to the compressor.

1. From the Pressure/Temperature Chart, record the corresponding Saturated Suction Temperature (**SST**) at the given suction pressure.
2. Calculate the system super heat using the formula below:

$$\text{Superheat} = \text{SLT} - \text{SST}$$

3. If superheat is within the range (see charging table), there is no need to add/remove refrigerant.
 - If superheat is lower than minimum, it means that liquid refrigerant may be returning to compressor. It is necessary to remove refrigerant or check EEV settings.
 - If superheat is higher than maximum, it means that refrigeration capability of evaporator is not fully maximised. It is necessary to add refrigerant charge or check EEV settings.

Allow the systems to stabilise (15 - 30 mins) and repeat the steps 1-3 until superheat falls within the range specified in the table below.

Subcooling/Superheat Table (K)			
Cooling		Heating	
Subcooling	Superheat	Subcooling	Superheat
4 - 8	4 - 8	10 - 14	1 - 4

NOTES

The above subcooling and superheat recommendations are based on the following rated conditions:

- Cooling: 35°C DB outdoor, air entering indoor at 27°C DB / 19°C WB.
- Heating: 7°C DB / 6°C WB outdoor, air entering indoor at 20°C DB Nominal indoor airflow.

Recording of Final R-32 Refrigerant Charge

In case adjustment of refrigerant charge is required, the total charge must not exceed the maximum charge as per "Minimum Room Area and Maximum Charge Guide" section of the R-32 Safety Manual.

The total R-32 charge (factory refrigerant charge + adjustment quantity of refrigerant) must be recorded in the "3570-082" label (Total Charge Amount Label) and the "Start Up and Commissioning Report" of the R-32 Safety Manual.

⚠ CAUTION

Ensure that no power supplied to the unit when filling out below sticker.

"IMPORTANT"

IT IS IMPORTANT TO RECORD THE FINAL R-32 REFRIGERANT CHARGE (KGS) OF THE SYSTEM USING AN INDELIBLE MARKER SO THAT FIGURES WILL NOT FADE OVER TIME. THIS INFORMATION IS NECESSARY FOR FUTURE SERVICING AND MAINTENANCE.

PRE-CHARGE AMOUNT kg

+

ADDITIONAL CHARGE kg

TOTAL CHARGE = kg

3570-082

- ← REFRIGERANT CHARGE AS SPECIFIED IN THE RATING LABEL
- ← ADJUSTMENT CHARGE; (-) IF R-32 IS RECLAIMED FROM THE SYSTEM
- ← FINAL CHARGE OF THE SYSTEM

Charging Table for R-32

Temp °C	Pressure KPa	Temp °C	Pressure KPa	Temp °C	Pressure KPa	Temp °C	Pressure KPa
-50	9	-19	320	11	1040	41	2439
-49	15	-18	336	12	1073	42	2500
-48	20	-17	353	13	1108	43	2564
-47	27	-16	369	14	1143	44	2628
-46	33	-15	387	15	1180	45	2694
-45	40	-14	405	16	1217	46	2760
-44	46	-13	424	17	1255	47	2829
-43	54	-12	442	18	1293	48	2898
-42	61	-11	462	19	1333	49	2969
-41	69	-10	481	20	1373	50	3040
-40	76	-9	502	21	1415	51	3114
-39	85	-8	523	22	1457	52	3187
-38	93	-7	545	23	1501	53	3264
-37	102	-6	567	24	1544	54	3340
-36	111	-5	590	25	1589	55	3419
-35	121	-4	613	26	1634	56	3498
-34	130	-3	637	27	1681	57	3580
-33	140	-2	661	28	1728	58	3662
-32	150	-1	687	29	1777	59	3747
-31	161	0	712	30	1826	60	3832
-30	172	1	739	31	1877	61	3920
-29	184	2	765	32	1928	62	4008
-28	195	3	793	33	1981	63	4099
-27	208	4	821	34	2034	64	4190
-26	220	5	851	35	2089	65	4284
-25	234	6	880	36	2144	66	4378
-24	247	7	911	37	2201	67	4476
-23	261	8	941	38	2258	68	4573
-22	275	9	974	39	2318	69	4675
-21	290	10	1006	40	2377	70	4776
-20	304						

Specifications for Refrigeration

REFRIGERATION PIPING - SINGLE PHASE					
Reverse Cycle (Outdoor / Indoor)		CRS10AS/ EVA10AS	CRS13AS/ EVA13AS	CRS15AS/ EVA15AS	CRS17AS/ EVA17AS
Max. Equivalent Pipe Length	metres	60			
Max. Vertical Height Differential	metres	20 (Included in Max. Pipe Length)			
Field Pipe Size					
Liquid Line	inch (mm)	3/8" (9.52)			
Gas Line	inch (mm)	5/8" (15.88)	3/4" (19.05)		
Indoor Pipe Size					
Liquid Line	inch (mm)	3/8" (9.52) swaged			
Gas Line	inch (mm)	5/8" (15.88)	3/4" (19.05)		
Outdoor Pipe Size					
Liquid Line	inch (mm)	3/8" (9.52) swaged			
Gas Line	inch (mm)	5/8" (15.88)	3/4" (19.05)		

REFRIGERATION PIPING - THREE PHASE						
Reverse Cycle (Outdoor / Indoor)		CRS13AT/ EVA13AS	CRS15AT/ EVA15AS	CRS17AT/ EVA17AS	CRS20AT/ EVA20AS	CRS23AT/ EVA23AS
Max. Equivalent Pipe Length	metres	60				
Max. Vertical Height Differential	metres	20 (Included in Max. Pipe Length)				
Field Pipe Size						
Liquid Line	inch (mm)	3/8" (9.52)				
Gas Line	inch (mm)	3/4" (19.05)		7/8" (22.22)		
Indoor Pipe Size						
Liquid Line	inch (mm)	3/8" (9.52) swaged		1/2" (12.7) swaged Cut to fit 9.52mm (3/8") field pipe		
Gas Line	inch (mm)	3/4" (19.05)		7/8" (22.22) swaged		
Outdoor Pipe Size						
Liquid Line	inch (mm)	3/8" (9.52) swaged		3/8" (9.52)		
Gas Line	inch (mm)	3/4" (19.05)		7/8" (22.22)		

Refrigerant Charge Details (R-32)

		SINGLE PHASE MODEL			
		CRS10AS	CRS13AS	CRS15AS	CRS17AS
Factory Charge	gm	2300	3400	3600	4100
Pre-charged Length *	m	10	15		
Minimum room area	m ²	4.541	7.318	8.204	10.641
Factory charge @2.2m release height					
Additional Refrigerant per metre	gm	40			
Maximum Refrigeration Charge @ Maximum Pipe Length	gm	4300	5200	5400	5900
/	/	/	/	/	/
Minimum room area @ 2.4m release height	m ²	11.705	17.117	18.459	22.036

* **Note:** If the installation is less than 15m, reduce refrigerant charge by 40g per meter.

Refrigerant Charge Details (R-32)

		THREE PHASE MODEL				
		CRS13AT	CRS15AT	CRS17AT	CRS20AT	CRS23AT
Factory Charge	gm	3300	3600	4100	5000	5400
Pre-charged Length *	m	15				
Minimum room area Factory charge @2.2m release height	m ²	6.894	8.204	10.641	15.826	18.459
Additional Refrigerant per metre	gm	40				
Maximum Refrigeration Charge @ Maximum Pipe Length	gm	5100	5400	5900	6800	7200
/	/	/	/	/	/	/
Minimum room area @ 2.4m release height	m ²	16.465	18.459	22.036	29.272	32.817

* **Note:** If the installation is less than 15m, reduce refrigerant charge by 40g per meter.

Minimum area are calculated based on 2.2 m release height. The higher the release height, the smaller minimum room area is required. Refer to TABLE 1.1 and 1.2 of the R-32 Safety Manual for minimum release height requirement for a given room.

Installation of this unit should be in accordance with Electrical Safety Standard, AS/NZS 60335.2.40.

If the smallest room to be conditioned is less than the required minimum room area (A_{min}), additional safety provision maybe needed such as leak detector sensor and/or ventilation to comply, for more details refer to Annex GG and Annex HH of the above standard.

Refer to R-32 (0525-101) Safety Manual for minimum required area of installation.

The Pre-Charge Amount is written on the Rating Label of the Outdoor unit. Where adjustment to charge is required to complete the refrigerating system, the installer should note the resulting "Additional/Reclaimed Charge" and "Total Charge" on the label of the Outdoor unit and "Start Up and Commissioning Report" of R-32 Safety Manual.

Maintenance

Maintenance Procedures

This section describes the procedures that must be performed as a part of normal maintenance program. Regular servicing of equipment by licensed technician is highly recommended. Regular servicing of your unit helps in maintaining its optimum performance and reliability. **The checklist and service periods provided on this manual are guides only, as some sites may require more frequent servicing.** Always disconnect electrical power to the unit before performing these procedures unless otherwise required. It is always a safe practice to observe all safety warnings and cautions when conducting maintenance tasks.



DANGER

Live Electrical Connections!

It may be necessary to work with live electrical components on certain maintenance tasks. Only licensed electricians and qualified technicians are allowed to perform these tasks.

Beware of Rotating Fan Blades!

Always make sure that all power supplied to the fans are turned Off and isolated.

Observe WH&S safety procedures, do not wear loose clothing and any jewellery when working near the fans.

Wear PPE whenever performing any maintenance procedures.

Observe all necessary procedures when working on a confined space.



WARNING

Hazardous Voltage!

Always make sure that all power supply, including remote controls, are disconnected before performing maintenance.

Observe proper LOCK-OUT/TAG-OUT procedures to ensure that power cannot be inadvertently energised. Failure to disconnect power before maintenance procedures can result in serious injury and/or death.

EC Motors are fitted with high power capacitors and can have dangerous residual voltages at motor terminals after power has been isolated. Wait at least 5 minutes after power isolation and test for any residual voltage before beginning service work.

Annual Maintenance Checklists

- Perform general maintenance inspections.
- Perform scheduled start-up checks.
- Leak test refrigerant circuits.
- Inspect contacts of all contactors and relays. Replace all worn contacts as required.
- Inspect, clean and tighten all electrical connections.
- Check fans for balanced operation. Make sure that there are no loose screws / bolts, no fan blades interference and no damage to the fans and guards.
- Inspect the air filters, clean or replace as required.
- Clean and repaint any corroded panel section.
- Ensure no blockage of airflow through variable speed drive.

Cleaning the Condenser Coils

Clean the coils at least once a year or more frequently if unit is located in a dusty and dirty environment, in order to maintain your system's proper operating performance. High discharge pressures are good indication that the coils need cleaning. When using detergent or solvents to clean the coils, follow the manufacturer's instructions to avoid potential damage to the coils and to the unit.

To clean the refrigerant coils, use a soft brush and water spray, such as garden hose or pressure washer with low pressure nozzle.

**WARNING****Do Not Use High Alkaline Detergent!**

When using detergent for coil cleaning, ensure that the alkaline level is no higher than 8.5, which can cause corrosion damage to the coils.

**DANGER****No Water into the Electrical Compartments!**

Ensure consideration is given to the possibility of water entering the electrical compartments during cleaning of the condenser coil.

Coil Cleaning Procedure

- Disconnect power to the unit.
- Remove the louvered panels from the unit to gain access to the air inlet side of the coils.
- Use a soft brush to remove loose dirt and debris from both sides of the coils.
- Straighten bent coil fins with fin comb.
- Prepare the detergent solutions according to the manufacturer's instructions.
- Spray solution at a 90° angle to the coils, keeping a minimum nozzle spray angle of 15°, with at least a 1800mm distance from the coils and 600 psi pressure.
- Spray leaving air side of the coils first then the air inlet side. Allow the solution to stand on the coils for five minutes.
- Rinse both sides of the coils with cool clean water.
- Inspect the coils, if they are still dirty, repeat the cleaning procedure.
- Clean and wipe dry the outer and inner sides of the unit, the refrigerating parts and other components.
- Ensure that the condensate drain lines are not blocked.
- Reinstall all unit panels, covers and guards.
- Restore electrical power to the unit.

Maintenance Frequency Checklist

Regular servicing of equipment by a qualified technician is recommended every 12 months for residential applications and every quarter for commercial applications. Regular servicing of your unit helps in maintaining its optimum performance and reliability. **The following checklist and service periods are provided as a guide only, as some sites may require more frequent servicing.**

ELECTRICAL											
Parts	Service Period					Detail of Service Check	Service Methods				
	1 Mth	3 Mth	6 Mth	1 Yr	2 Yrs			3 Yrs	4 Yrs	5 Yrs	
Printed Circuit Boards				✓						Visual Inspection	Tighten Terminals as necessary on printed circuit boards
Electrical Connections				✓						Check all electrical terminals, mains, communications, etc	Re-tighten if loose.

OUTDOOR UNIT											
Parts	Service Period					Detail of Service Check	Service Methods				
	1 Mth	3 Mth	6 Mth	1 Yr	2 Yrs			3 Yrs	4 Yrs	5 Yrs	
Casing / Panels and Frames				✓						Visual check for damage, rust and dust accumulation.	For highly corrosive environment, wash panels quarterly with water and neutral detergent solution. Wax panels. Repair / re-paint where required.
Insulation				✓						Visual check for insulation conditions.	Repair / replace insulation material.
Fan				✓						Visual check for run out of balance and dust attached	Clean off dust as necessary to negate possibility of fan running out of balance
Motor				✓ Ω						Visual check on wiring. Insulation resistance check to be carried out annually	Measure insulation resistance. Should be more than 1MΩ
Heat Exchanger				✓						Check for clogging by dust. Check for leaks / damage.	Clean air inlet side as necessary. Straighten any bent fins using fins comb.
Condensate Drain Line (if available)				✓						Check for obstructions and free flow of water	Clean to eliminate obstructions/sludge and check condition of drain line. Pour water to ensure free flow.
Compressor				✓ Ω						Check for high / low pressure. Measure insulation resistance. Check compressor for abnormal noise/vibrations	Measure insulation resistance. Should be more than 1MΩ.
Refrigeration Operational Readings				✓						Make note of operational reading in test cool/heat	Check operating pressures, record superheat and subcooling values
Safety Devices				✓						Check calibration of safety devices such as HP and LP controls, sensors, etc	Check resistance of sensors, pressure cut in / cut out of pressure controls
Faults				✓						Check for any previous fault history on unit.	Investigate any causes for previous faults, reset fault history.

Version History

DOCUMENT VERSION	BOM VERSION	UPDATE HISTORY
Ver 1	-0100	Released
Ver 2	-0100	Updated menu tree in the Configuring and Commissioning Setup
Ver 3	-0100	Added 20kW and 23kW units
Ver 4	-0100	Updated 20/23kW net and gross weight Updated Pressure testing Replaced ANZ 3000/8 with NZS 3000/8 as standard



©Copyright 2023 Actron Engineering Pty Limited ABN 34 002767240. ®Registered Trade Marks of Actron Engineering Pty Limited. ActronAir is constantly seeking ways to improve the design of its products. Therefore, specifications are subject to change without notice.