

# PACKAGE UNIT



## UNIT FEATURES

- Compliant Scroll Compressor
- Pre-charged with R-410A Refrigerant
- Multiple Speed Outdoor Fans
- Hydrophilic Blue Fin coil Coat Protection - Indoor & Outdoor Coils
- Louvred Outdoor Coil Guard
- EC Variable Speed Indoor Fan
- Adjustable Dial-Up Indoor Airflow
- Adaptive Demand Defrost

Integrated Condensate Safety Drain Tray

## UNIT OPTIONS

- Low Ambient
- Compressor Soft Starters
- Phase Protection
- Additional Full Coil Coat Protection
- Fault Detection Board

## CONTROL OPTIONS

### ActronAir C7-4 (BCA Compliant)

- 7-Day Programmable Controller with 2 Events/Day
- Temperature Set Back and After Hours Timer
- Zone Kit for Control up to 4 Zones (See Control Section)
- Auto, Heat & Cool Modes
- Auto/Continuous Indoor Fan Operation
- 1 Speed Indoor Fan Setting
- Hot Start Feature
- 2 Stage Cooling/Heating with 3rd Stage Boost Heat
- Manual Control Inputs
- Remote Temperature Sensors
- 24-Hour ON/OFF Timer
- Home/Building Automation ON/OFF Capability

## UNIT COMPLIANCE

- MEPS 2012 / GEMS 2012
- AS/NZS 4755.3.1 Demand Response Capabilities
- AS/NZS 60335.1 Electrical Appliance Safety
- AS/NZS CISPR 11:2011 (Group 1 ClassA) EMC Compliance

## SPECIFICATION SUMMARY

PACKAGE MODEL	PCG340U	
	<sup>(1)</sup> TOTAL	<sup>(2)</sup> NETT
<sup>(3)</sup> COOLING CAPACITY (kW)	33.40	32.50
<sup>(3)</sup> SENSIBLE CAPACITY (kW)	28.20	27.30
<sup>(4)</sup> HEATING CAPACITY (kW)	34.10	35.00
<sup>(5)</sup> COOLING INPUT POWER (kW)	9.85	
<sup>(5)</sup> HEATING INPUT POWER (kW)	9.94	
EER	3.39	3.30
COP	3.43	3.52
<sup>(6)</sup> INDOOR AIRFLOW (l/s) - MIN. / NOMINAL / MAX.	1450 / 1770 / 1900	
<sup>(7)</sup> OUTDOOR SOUND PRESS. LEVEL @ 3M dB(A) - LOW / HIGH	58.8 / 62.8	
OUTDOOR SOUND POWER LEVEL dB(A) -- LOW / HIGH	75.8 / 79.8	
POWER SUPPLY	400V / 3Ph+N / 50Hz	
<sup>(2)</sup> RATED LOAD AMPS	20.7	
<sup>(8)</sup> FULL LOAD AMPS	35.9	
<sup>(9)</sup> CIRCUIT BREAKER AND CABLE AMPS	40.0	
APPROXIMATE STARTING AMPS	64.0	
WEIGHT (kg)	500	

<sup>(1)</sup> Based on unit rating excluding indoor fan kW.

<sup>(2)</sup> Measured and tested in accordance with AS/NZS 3823.1.2.

<sup>(3)</sup> At 27°C DB / 19°C WB entering air temperatures and 35°C ambient.

<sup>(4)</sup> At 20°C DB entering air temperature and 7°C DB / 6°C WB ambient.

<sup>(5)</sup> Input power includes indoor fan kW.

<sup>(6)</sup> Max. - Min. airflow application range.

<sup>(7)</sup> Outdoor sound pressure level is determined in an anechoic chamber and may differ once the unit is installed due to environment conditions.

<sup>(8)</sup> Full Load Amps are based on compressor and fan motors' maximum expected current.

<sup>(9)</sup> See Specifications sheet for cable size and circuit breaker size details.

Note: Use input power to estimate running cost.

3 Phase  
2 Stage  
33.40 kW





## PACKAGE UNIT - STANDARD MODEL

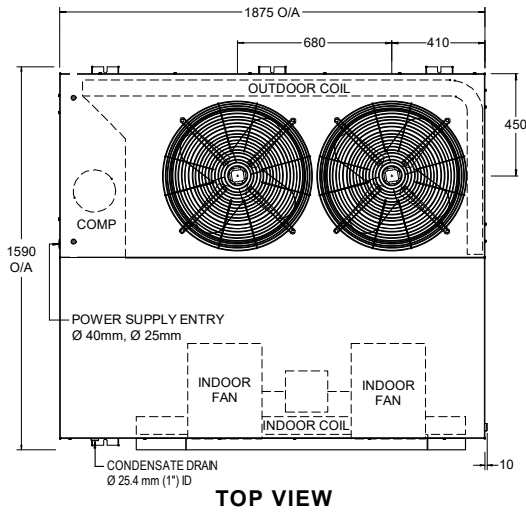

OVERALL NOMINAL DIMENSION (H x W x D)  
= 1330 x 1875 x 1590  
SUPPLY DUCT (H x W) = 300 x 1065  
RETURN DUCT (H x W) = 525 x 1450  
USE M12 BOLT FOR FEET MOUNTING

CONDENSATION POINTS ARE DESIGNED TO ENSURE ALL CONDENSATION IS REMOVED EFFICIENTLY TO AVOID WATER POOLING WITHIN THE CONDENSER. IF A SINGLE CONDENSATION DRAIN POINT IS REQUIRED, ACTRONAIR RECOMMENDS THE INSTALLATION OF A CONDENSER TRAY. THESE ARE AVAILABLE AS AN ADDITIONAL ACCESSORY.  
\*\* DRAWING IS SUBJECT TO CHANGE WITHOUT NOTICE\*\*

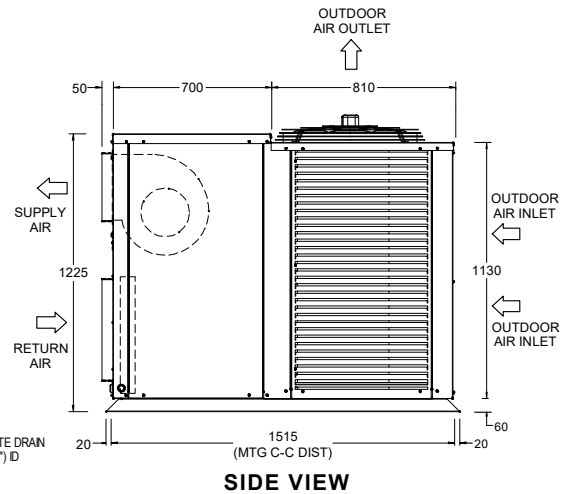
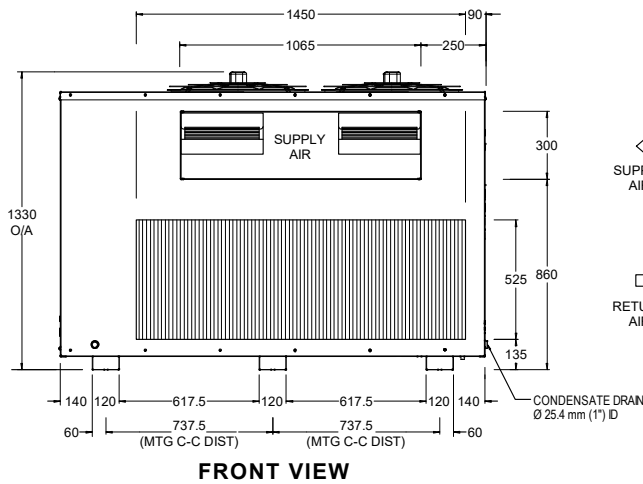

UNIT MODEL NUMBER	UNIT WEIGHT (kg)	CORNER WEIGHTS (kg)					
		A	B	C	D	E	F
PCG340U	500	62.0	53.4	129.3	52.4	53.4	149.5

### MINIMUM SERVICE ACCESS AREAS AND AIRFLOW CLEARANCES

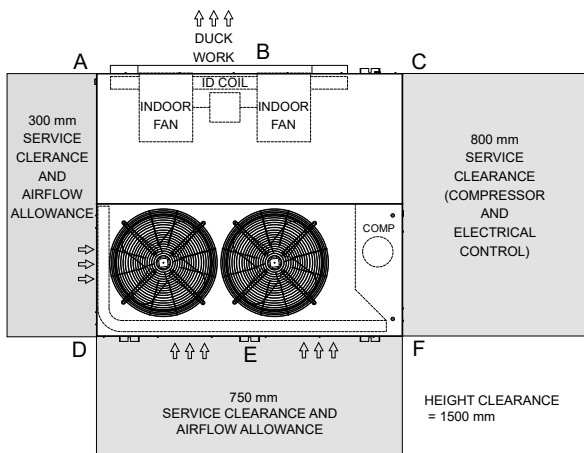

#### NOTES:

- Do not scale drawing. All dimensions are in mm unless specified. Refer to corresponding unit dimensional drawing for mounting hole details.
- Ensure that Service Access Areas and Spaces for Airflow Clearances are met. This is based on the condition that the spaces around the units are free from any obstructions and a walkway passage of 1000mm between the units or between the unit and the outside perimeter is available.
- Minimum service access areas and spaces for airflow clearances are responsibilities of the installer, ActronAir will not be held liable for any extra charges incurred due to lack of access and space for airflow.
- Under all circumstances, condenser air must not recirculate back onto condenser coil. Keep all clearance free of any obstructions.
- MTG C-C DIST = Mounting Centre to Centre Distance.
- Use M12 bolt for feet mounting.

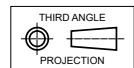

AIRFLOW (l/s)	EXTERNAL STATIC PRESSURE (Pa)													
	50		100		150		200		250		300		350	
	% PWM	W	% PWM	W	% PWM	W	% PWM	W	% PWM	W	% PWM	W	% PWM	W
1450	<b>MOTOR / BLOWER LIMIT</b>		50	626	55	767	59	892	64	1042	73	1192	90	1350
1500	<b>MOTOR / BLOWER LIMIT</b>		53	680	57	797	62	953	67	1096	77	1253	94	1416
1550	51	597	56	734	60	853	65	1012	70	1172	81	1316	<b>MOTOR / BLOWER LIMIT</b>	
1600	54	647	58	761	63	912	68	1076	73	1217	86	1387		
1650	57	700	61	816	66	969	71	1138	75	1278	90	1453		
1700	60	750	65	898	69	1029	74	1198	79	1348	95	1531		
1750	63	804	68	958	72	1089	77	1261	83	1419	<b>MOTOR / BLOWER LIMIT</b>			
1770	64	820	69	974	74	1127	78	1279	85	1452				
1800	66	858	71	1015	75	1146	80	1324	88	1503				
1850	69	913	74	1072	79	1244	84	1410	93	1585				
1900	72	969	77	1131	82	1304	88	1494	<b>MOTOR / BLOWER LIMIT</b>					

**NOTES:**

**W** = Indoor Fan Power, Watts

**PWM** = Pulse Width Modulation Setting, % PWM

(Adjustable through CPI3-1 Board located in electrical panel).

Factory PWM Setting = 69 % PWM for 100 Pa.

   - Data in the box indicates Factory Default Setting.

**(CPI3-1) COMMERCIAL PWM INTERFACE BOARD**

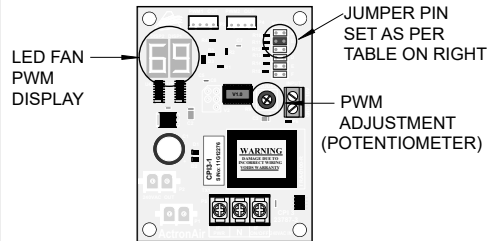

JUMPER PIN POSITION	INDOOR FAN
A	SCG400E PCG400U/L/R
B	SCG340E PCG340U/L/R
C	SCG330E PCG330U/L/R
D	PCG300L/R
E	SCG290E PCG290U/L/R
F	SCG260E PCG260U/V

**NOTES:**

• LED will show PWM without %.

Example: 69% PWM = 69 in LED.

• LED adjustments are in 1 digit increment.

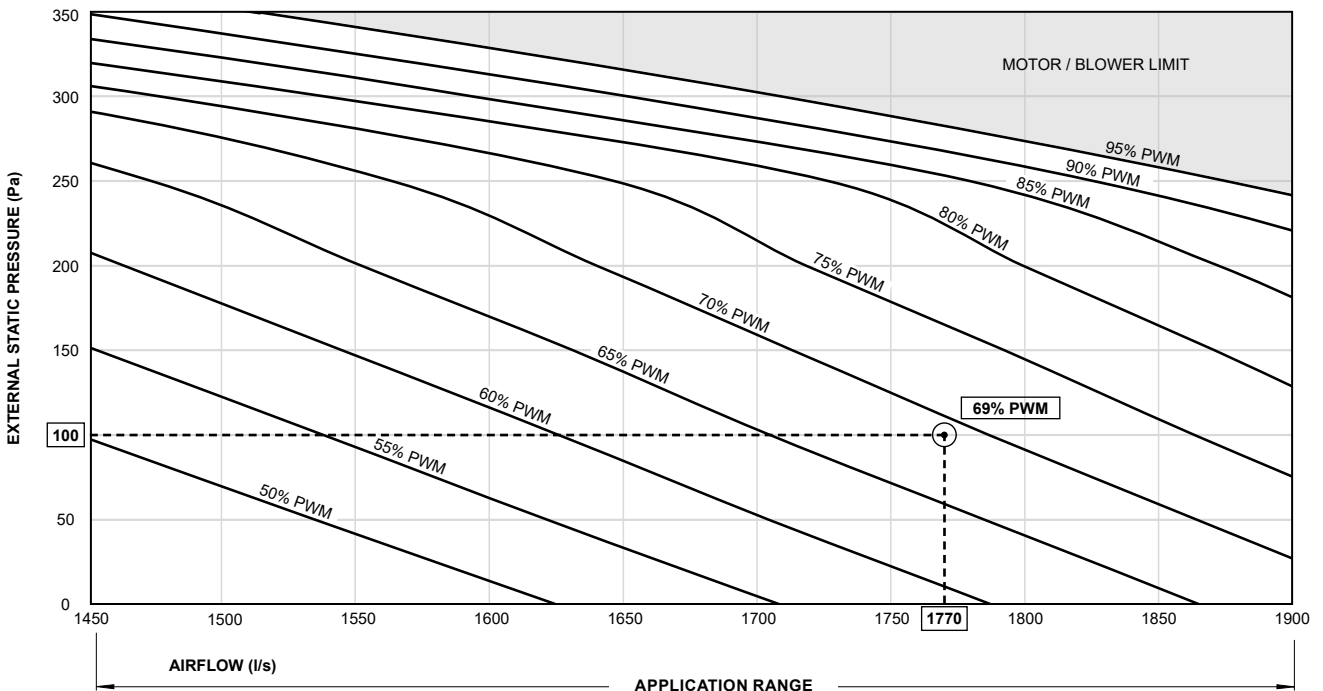

Nominal Airflow = 1770 l/s  
2.5 Face Velocity will occur at 2156l/s.



33.40 kW  
3 Phase  
2 Stage

**Outdoor Radiated**

**Sound Power Level (SWL)**

Fan Speed	Sound Power Level dB(A)	Octave Band Centre Frequency (Hz), dB						
		125	250	500	1k	2k	4k	8k
Low	75.8	75.2	73.6	73.1	71.1	66.9	65.0	59.7
High	79.8	78.2	77.8	77.0	75.3	71.0	69.0	63.9

**Indoor Outlet**

**Sound Power Level (SWL)**

Airflow Setting	Airflow Li/s	Sound Power Level dB(A)	Octave Band Centre Frequency (Hz), dB						
			125	250	500	1k	2k	4k	8k
Nominal	1720	81.0	79.5	80.1	78.0	75.8	73.2	69.5	64.5

**OUTDOOR RADIATED**

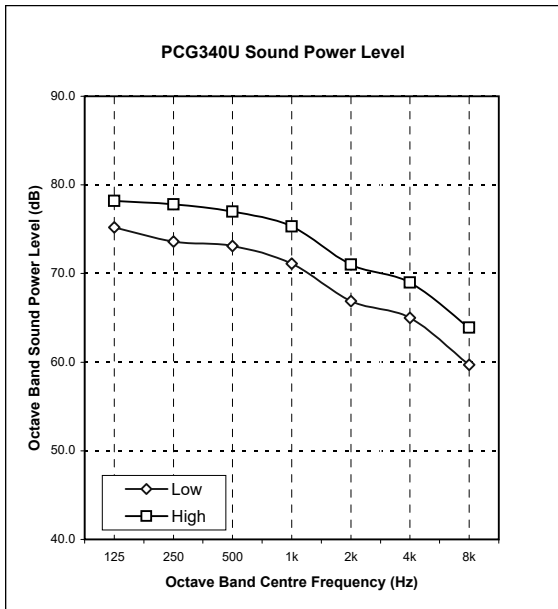

**INDOOR OUTLET**

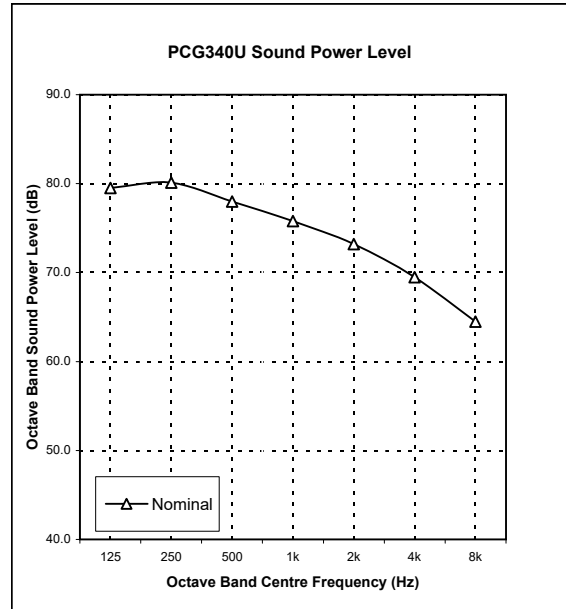

**33.40 KW**  
3 Phase  
2 Stage

**NOTE:**

Radiated sound power levels are based on ISO 3743-1.



# SPECIFICATIONS

# PCG340U

CONSTRUCTION	
CABINET BASE	1.6 mm Galvanized Steel
CABINET TOP AND SIDES	0.9 - 1.2 mm ZA & Galv. Steel
SURFACE FINISH	65 microns Baked Polyester Powder Coat

INSULATION	
TYPE	Foil Faced Polyethylene Expanded Polystyrene

ELECTRICAL	
POWER SUPPLY - 50 Hz	400 Volts x 3 Phase + Neutral
VOLTAGE RANGE (min - max)	380V - 440V
FULL LOAD AMPS * - Phase 1	35.9
FULL LOAD AMPS * - Phase 2 and 3	21.3 and 22.4
RATED LOAD AMPS**	21.3
APPROX. STARTING AMPS	64.0
IP RATING	IP44

IMPORTANT - The local electricity authority may require limits on starting current and voltage drop, please check prior to purchase.

\* Full Load Amps are based on compressor and fan motor's maximum expected current.

\*\* Rated Load Amps are measured and tested in accordance with AS/NZS3823.1.2.

CABLE SIZE & CIRCUIT BREAKER SIZE	
1. Cable size recommendation selected in accordance to maximum conductor temperature of 75°C with wiring enclosed in air.	
2. Suggested minimum cable size should be used as a guide only, refer to AS/NZS 3000 "Australian/New Zealand Wiring Rules" for more details.	
CABLE SIZE (MAIN LINE)	10.0mm <sup>2</sup> (SUGGESTED MINIMUM)
CIRCUIT BREAKER SIZE - AMPS	40.0

OUTDOOR COIL	
TUBE TYPE	Copper - Rifle Bore
FIN TYPE	Aluminium - Wave
FACE AREA (m sqr)	2.50
FIN SPACING (per m)	472
COIL COATING	Hydrophilic Blue Fin Coil Coat Protection

OUTDOOR FAN	
NUMBER OF FANS x TYPE	2 x Axial
NUMBER OF BLADES PER FAN	4
DIAMETER (mm)	560
OUTPUT kW	0.37
MOTOR TYPE / DRIVE TYPE	6 Pole External Rotor / Direct Drive
FAN SPEED CONTROL	2 Speed via Capacitor
The standard type outdoor fans fitted to this unit will accept up to 5Pa of external static resistance.	

INDOOR COIL	
TUBE TYPE	Copper - Rifle Bore
FIN TYPE	Aluminium - Louvre
FACE ARE (m sqr)	0.86
FIN SPACING (per m)	472
COIL COATING	Hydrophilic Blue Fin Coil Coat Protection

INDOOR FAN	
NUMBER OF FANS x TYPE	1 x Twin Deck Centrifugal EC Fan
DIAMETER / WIDTH (mm)	270 x 270
OUTPUT kW / INPUT kW	1.12 / 0.90
MOTOR TYPE / DRIVE TYPE	Variable Speed EC Motor / Direct

COMPRESSOR	
NUMBER PER UNIT x TYPE	2 x Scroll (Hermetic)
FULL LOAD AMPS	19.4
LOCKED ROTOR AMPS	64.0
STARTING METHOD	D.O.L. (optional soft starter)

REFRIGERATION SYSTEM	
REFRIGERANT TYPE	R-410A
EXPANSION CONTROL	Direct Expansion Orifice
FACTORY CHARGE (grams)	6,910 per stage (per compressor)

FILTER DRIER	
CONNECTION SIZE & TYPE	9.52 mm (3/8") ODF Soldered Bi-Flow
FACTORY SUPPLIED / FITTED	No
See Installation Section for complete Filter Drier specifications.	

PROTECTION DEVICES	
HIGH PRESSURE CUTOOUT SWITCH	Nonadjustable (Automatic Reset)
LOW PRESSURE CUTOOUT SWITCH	Nonadjustable (Automatic Reset)
COMPRESSOR MOTOR TEMP.	Internal Thermal Cut-Out
INDOOR FAN OVERLOAD	Internal Thermal Cut-Out
OUTDOOR FAN OVERLOAD	Internal Thermal Cut-Out
SUMP HEATER WATTS	2 x 30 W during Comp. Off Cycle

ELECTRIC CONTROLS	
DEFROST METHOD	Reverse Cycle
DEFROST TYPE	Adaptive Demand Defrost
CONTROL CIRCUIT BREAKER	16.0 Amps
CONTROL FIELD WIRING	2 Core 14 / 0.20 Screened Cable

**OPERATING RANGE**  
It is essential that the unit is correctly sized for the application and operates within its recommended range of operating conditions as shown below.

MODE	RANGE	INDOOR AIR INTAKE TEMPERATURE	OUTDOOR AIR INTAKE TEMPERATURE	
Cooling	Max.	30°C DB / 22°C WB	50°C DB	
	Min.	20°C DB / 16°C WB	15°C DB	
Heating	Max.	24°C DB	19.5°C DB / 18°C WB	
	Min.	16°C DB	-10°C WB	
IMPORTANT - For low ambient cooling use option S. Lower ambient available on request. Contact your nearest ActronAir office for more details.				
Low Ambient Cooling	Option S	Max.	29°C DB / 19°C WB	50°C DB
		Min.	20°C DB / 15°C WB	5°C DB
	On Request	Max.	29°C DB / 19°C WB	50°C DB
		Min.	20°C DB / 15°C WB	-5°C DB

**AIR FILTERS**  
All return air including fresh air must have adequate filters supplied and fitted by the installing contractor. Filters must be located in accessible location between the return air grille and the unit.  
ActronAir does not supply or make any provisions for return air filter.

33.40 kW  
3 Phase  
2 Stage



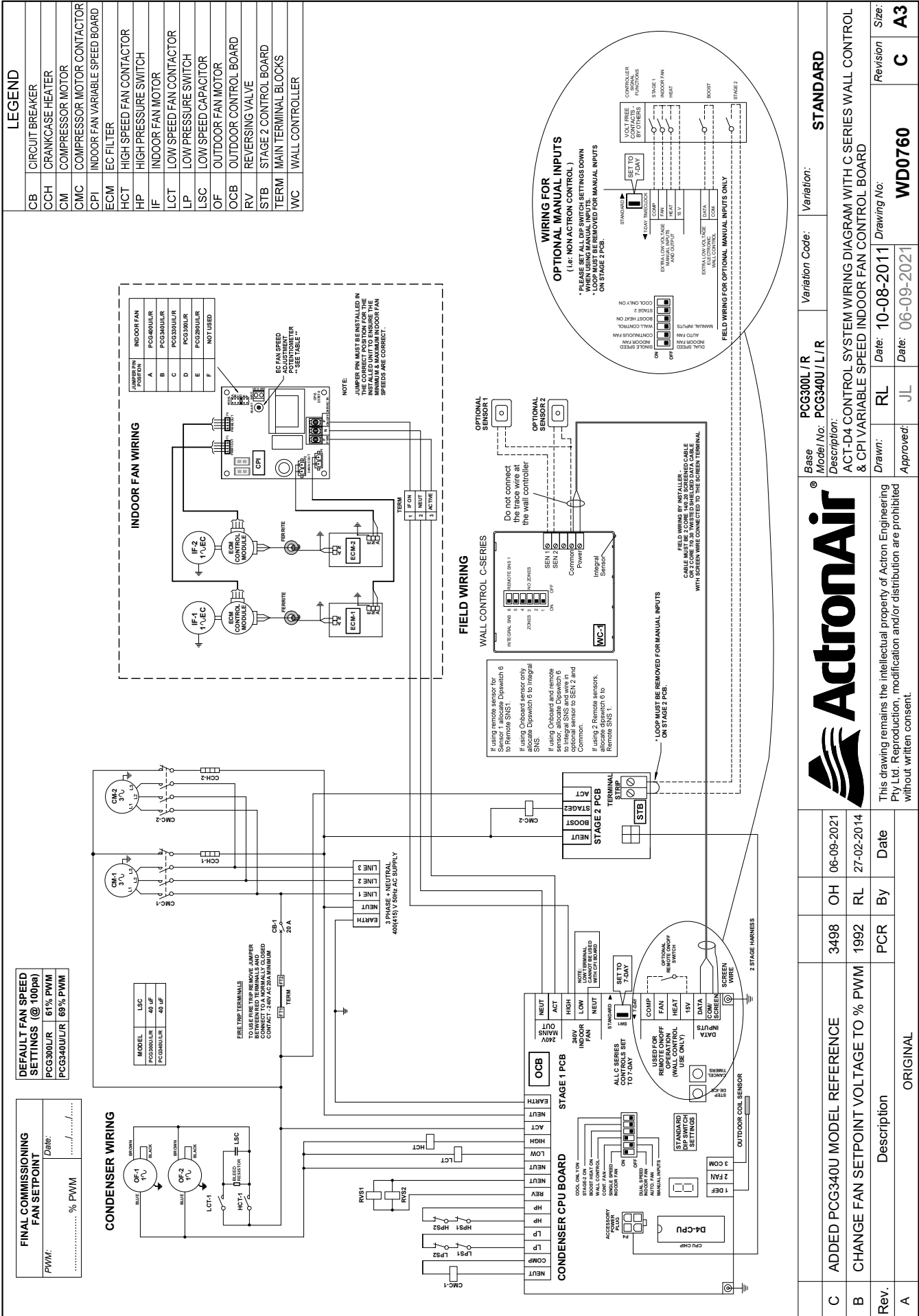

Base Model No: PCG300L/R Variation Code: **STANDARD**

PCG340U/L/R

Description:  
 ACT-D4 CONTROL SYSTEM WIRING DIAGRAM WITH C SERIES WALL CONTROL & CPI VARIABLE SPEED INDOOR FAN CONTROL BOARD

Drawn: **RL** Date: **10-08-2011** Drawing No: **WD0760**

Approved: **JL** Date: **06-09-2021**

Revision: **C** Size: **A3**

3 Phase  
 2 Stage  
 33.40 kW

## V PACKAGE UNIT - WITH FAN COIL VERTICAL DISCHARGE

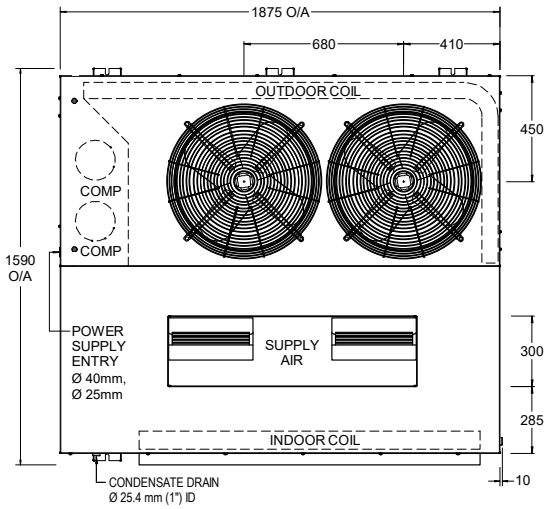

**TOP VIEW**

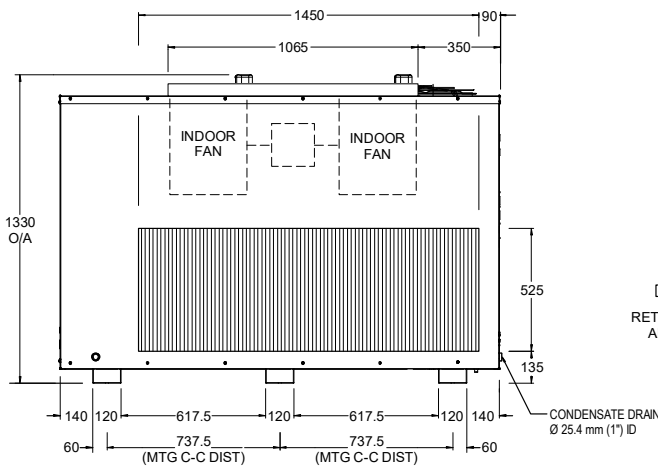

**FRONT VIEW**

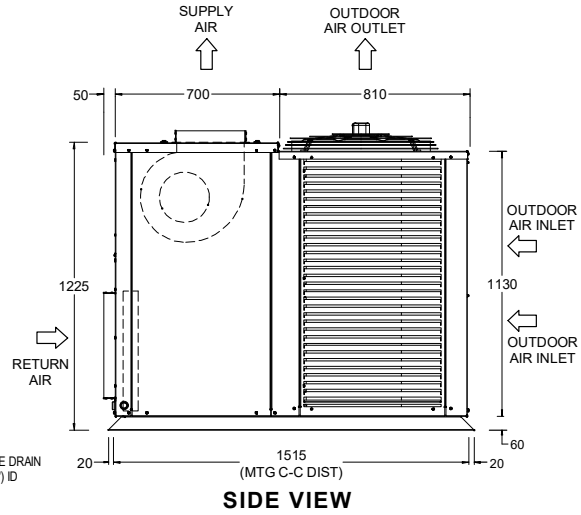

**SIDE VIEW**

OVERALL NOMINAL DIMENSION (H x W x D)  
= 1330 x 1875 x 1590  
SUPPLY DUCT (H x W) = 300 x 1065  
RETURN DUCT (H x W) = 525 x 1450  
USE M12 BOLT FOR FEET MOUNTING

CONDENSATION POINTS ARE DESIGNED TO ENSURE ALL CONDENSATION IS REMOVED EFFICIENTLY TO AVOID WATER POOLING WITHIN THE CONDENSER. IF A SINGLE CONDENSATION DRAIN POINT IS REQUIRED, ACTRONAIR RECOMMENDS THE INSTALLATION OF A CONDENSER TRAY. THESE ARE AVAILABLE AS AN ADDITIONAL ACCESSORY.

\*\* DRAWING IS SUBJECT TO CHANGE WITHOUT NOTICE\*\*

UNIT MODEL NUMBER	UNIT WEIGHT (kg)	CORNER WEIGHTS (kg)					
		A	B	C	D	E	F
PCG340V	500	62.0	53.4	129.3	52.4	53.4	149.5

### MINIMUM SERVICE ACCESS AREAS AND AIRFLOW CLEARANCES

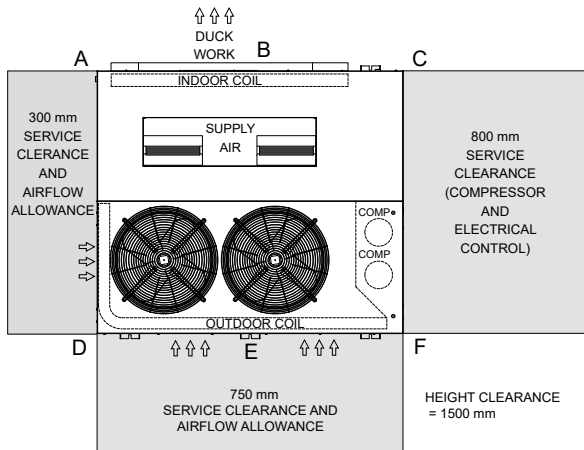

#### NOTES:

- Do not scale drawing. All dimensions are in mm unless specified. Refer to corresponding unit dimensional drawing for mounting hole details.
- Ensure that Service Access Areas and Spaces for Airflow Clearances are met. This is based on the condition that the spaces around the units are free from any obstructions and a walkway passage of 1000mm between the units or between the unit and the outside perimeter is available.
- Minimum service access areas and spaces for airflow clearances are responsibilities of the installer, ActronAir will not be held liable for any extra charges incurred due to lack of access and space for airflow.
- Under all circumstances, condenser air must not recirculate back onto condenser coil. Keep all clearance free of any obstructions.
- MTG C-C DIST = Mounting Centre to Centre Distance.
- Use M12 bolt for feet mounting.

