

MULTI SPLIT SYSTEM



1 Phase
1 Stage
9.85 kW

UNIT FEATURES	Wall Hung	Bulkhead	Mini Cassette
Reverse Cycle Multi-Split System	Yes	Yes	Yes
Mono & Multi Compatible Heads	Yes	N/A	N/A
Twin-Rotary Compressor	Yes	Yes	Yes
Superior Operating Range:			
◦ Cooling: up to 50°C DB	Yes	Yes	Yes
◦ Heating: down to -25°C DB	Yes	Yes	Yes
Adjustable Airflow	Yes	Yes	Yes
3D Multi-Directional Airflow:			
◦ Up/Down Auto Swing	Yes	N/A	N/A
◦ Left/Right Auto Swing	Yes	N/A	N/A
Louvre Position Memory	Yes	N/A	N/A
Fan Speed: Auto, Low, Medium and High	Yes	Yes	Yes
Powder Coated Panels - Outdoor Unit	Yes	Yes	Yes
Hydrophilic Indoor and Outdoor Coil Protection	Yes	Yes	Yes
BIO Filter	Yes	N/A	N/A
Self-Diagnosis and Auto Protection	Yes	Yes	Yes
1W Standby Power Consumption	Yes	N/A	N/A
Fire Proof Electrical Box - Indoor & Outdoor	Yes	Yes	Yes

UNIT OPTION	Yes	Yes	N/A
Left or Right Hand Drain Connection	Yes	Yes	N/A

CONTROL FEATURES	Yes	N/A	Optional
WRE2621	Yes	N/A	Optional
RC-02	Yes*	N/A	N/A
WC-02 Wired Controller	Optional	Yes	Yes
Digital Display	Yes	Yes	Yes
Auto Restart After Power Failure	Yes	Yes	Yes
Timer Operation	Yes	Yes	Yes
Remote ON/OFF Input	Optional	Yes	Yes
Manual ON/OFF Operation	Yes	Yes	Yes
Indoor Fan Speeds	12 Speed	3 Speed	3 Speed
Outdoor Fan Speeds	5 Speed	5 Speed	5 Speed
Sleep Mode	Yes	N/A	Yes
Turbo Mode	Yes	N/A	Yes
Dry Mode Operation	Yes	Yes	Yes
Demand Response Ready	Yes	Yes	Yes
Auto Defrost Function	Yes	Yes	Yes
Follow Me Function	Yes	Yes	Yes
Mute Operation	Yes	N/A	N/A
Self Clean Function	Yes	N/A	N/A
Fault Alarm Output	Optional	Yes	Yes

UNIT COMPLIANCE
 AS/NZS 3823.2 (MEPS)
 AS/NZS 4755.3.1 (DRM 1, 2 and 3)
 AS/NZS CISPR 14.1 (EMC)
 AS/NZS 60335.1 (ELECTRICAL APPLIANCE SAFETY)
 AS/NZS 60335.2.40 (ELECTRICAL APPLIANCE SAFETY - AIR CONDITIONERS)

SPECIFICATION SUMMARY		MRC-100AS-4
OUTDOOR UNIT MODEL	MRC-100AS-4	
	NETT	
(1)(2) COOLING CAPACITY (kW) NOMINAL	9.85	
(1) (3) HEATING CAPACITY (kW) NOMINAL	9.90	
(1) (4) COOLING INPUT POWER (kW)	2.48	
(1) (4) HEATING INPUT POWER (kW)	2.58	
(1)(2) EER	3.97	
(1)(3) COP	3.84	
OUTDOOR SOUND PRESS. LEVEL @ 1M dB(A)	61	
(6) OUTDOOR SOUND POWER LEVEL dB(A)	69	
POWER SUPPLY	220 - 240V / 1Ph+N / 50 Hz	
INDOOR UNIT WIRING METHOD	Hard wire to Outdoor	
(1) RATED LOAD AMPS COOLING / HEATING	10.9 / 11.4	
(6) FULL LOAD AMPS	19.7 (MAX)	
(7) CIRCUIT BREAKER AND CABLE AMPS	20.0	
WEIGHT (kg)	71	
OD OPERATING RANGE (°C)	COOLING	-15 to 50
	HEATING	-25 to 30

(1) Measured and tested in accordance with AS/NZS 3823.1.4. Rated Load Amps shown above is based on MEPS representative outdoor and indoor unit combinations.
 (2) At 27°C DB / 19°C WB entering air temperatures and 35°C ambient.
 (3) At 20°C DB entering air temperature and 7°C DB / 6°C WB ambient.
 (4) input power includes indoor fan kW.
 (5) Determination of Sound Power Levels of Noise Sources per AS1217.2.
 (6) Full Load Amps (FLA) shown above is based on maximum possible outdoor and indoor unit combinations. FLA are based on compressor and fan motors' maximum expected current.
 (7) See Specifications sheet for cable size and circuit breaker size details.

Note: Use input power to estimate running cost.

*Only applicable to Serene 2 models.



CAPACITY COMBINATION TABLE

MRC-100AS-4

9.85 kW
1 Phase 1 Stage

COOLING PERFORMANCE		UNIT COMBINATION				UNIT CAPACITY (kW)				NET COOLING CAPACITY RANGE (kW)			
		UNIT A	UNIT B	UNIT C	UNIT D	UNIT A	UNIT B	UNIT C	UNIT D	MIN	RATED	MAXIMUM	
1 - HEAD	2.6kW	—	—	—	—	3.16	—	—	—	2.05	3.16	4.04	
	3.5kW	—	—	—	—	3.68	—	—	—	2.39	3.68	4.71	
	5.0kW	—	—	—	—	5.05	—	—	—	3.13	5.05	6.46	
	7.1kW	—	—	—	—	7.08	—	—	—	4.39	7.08	9.06	
2 - HEADS	2.6kW	2.6kW	—	—	—	2.73	2.73	—	—	2.29	5.45	6.65	
	2.6kW	3.5kW	—	—	—	2.80	3.44	—	—	2.62	6.24	7.61	
	2.6kW	5.0kW	—	—	—	2.31	4.44	—	—	2.84	6.75	8.24	
	2.6kW	7.1kW	—	—	—	2.13	5.75	—	—	4.89	7.88	9.06	
	3.5kW	3.5kW	—	—	—	3.36	3.36	—	—	2.82	6.72	8.20	
	3.5kW	5.0kW	—	—	—	2.74	4.54	—	—	3.06	7.28	8.88	
	3.5kW	7.1kW	—	—	—	2.72	5.43	—	—	5.05	8.15	9.37	
	5.0kW	5.0kW	—	—	—	4.05	4.05	—	—	3.40	8.09	9.87	
3 - HEADS	2.6kW	2.6kW	2.6kW	—	—	2.60	2.60	2.60	—	3.28	7.80	9.52	
	2.6kW	2.6kW	3.5kW	—	—	2.47	2.47	3.32	—	3.47	8.26	10.08	
	2.6kW	2.6kW	5.0kW	—	—	2.19	2.19	4.22	—	3.61	8.60	10.49	
	2.6kW	3.5kW	3.5kW	—	—	2.29	3.08	3.08	—	3.54	8.44	10.30	
	2.6kW	3.5kW	5.0kW	—	—	2.07	2.79	3.99	—	3.72	8.85	10.80	
	3.5kW	3.5kW	3.5kW	—	—	2.85	2.85	2.85	—	3.59	8.55	10.43	
4 - HEADS	2.6kW	2.6kW	2.6kW	2.6kW	2.6kW	2.46	2.46	2.46	2.46	4.01	9.85	11.93	
	2.6kW	2.6kW	2.6kW	3.5kW	2.6kW	2.36	2.36	2.36	2.91	4.08	10.00	12.13	



HEATING PERFORMANCE		UNIT COMBINATION				UNIT CAPACITY (kW)				NET HEATING CAPACITY RANGE (kW)		
		UNIT A	UNIT B	UNIT C	UNIT D	UNIT A	UNIT B	UNIT C	UNIT D	MIN	RATED	MAXIMUM
1 - HEAD	2.6kW	—	—	—	—	3.28	—	—	—	2.13	3.28	4.20
	3.5kW	—	—	—	—	3.75	—	—	—	2.44	3.75	4.80
	5.0kW	—	—	—	—	5.22	—	—	—	3.24	5.22	6.68
	7.1kW	—	—	—	—	6.55	—	—	—	4.06	6.55	8.38
2 - HEADS	2.6kW	2.6kW	—	—	—	2.79	2.79	—	—	2.34	5.58	6.81
	2.6kW	3.5kW	—	—	—	2.63	3.23	—	—	2.46	5.86	7.15
	2.6kW	5.0kW	—	—	—	2.51	4.83	—	—	3.08	7.34	8.95
	2.6kW	7.1kW	—	—	—	2.25	6.07	—	—	5.16	8.32	9.57
	3.5kW	3.5kW	—	—	—	3.36	3.36	—	—	2.82	6.72	8.20
	3.5kW	5.0kW	—	—	—	3.12	5.16	—	—	3.48	8.28	10.10
	3.5kW	7.1kW	—	—	—	2.88	5.77	—	—	5.36	8.65	9.95
	5.0kW	5.0kW	—	—	—	4.05	4.05	—	—	3.40	8.09	9.87
3 - HEADS	2.6kW	2.6kW	2.6kW	—	—	2.69	2.69	2.69	—	3.39	8.06	9.83
	2.6kW	2.6kW	3.5kW	—	—	2.47	2.47	3.32	—	3.47	8.26	10.08
	2.6kW	2.6kW	5.0kW	—	—	2.19	2.19	4.22	—	3.61	8.60	10.49
	2.6kW	3.5kW	3.5kW	—	—	2.34	3.15	3.15	—	3.63	8.64	10.54
	2.6kW	3.5kW	5.0kW	—	—	2.00	2.69	3.85	—	3.59	8.54	10.42
	3.5kW	3.5kW	3.5kW	—	—	3.11	3.11	3.11	—	3.92	9.33	11.38
	2.6kW	2.6kW	2.6kW	2.6kW	—	2.48	2.48	2.48	2.48	4.31	9.90	12.81
	2.6kW	2.6kW	2.6kW	3.5kW	—	2.36	2.36	2.36	2.91	4.36	10.00	12.96
4 - HEADS	2.6kW	2.6kW	2.6kW	2.6kW	—	2.36	2.36	2.36	2.91	4.36	10.00	12.96

PIPE LENGTH CORRECTION MULTIPLIER

	5m	10m	15m	20m	25m	30m	35m
COOLING	1.000	0.978	0.956	0.934	0.920	0.8875	0.880
HEATING	1.000	0.9815	0.963	0.946	0.934	0.925	0.910

NOTES:

- No allowance has been made for the effect of indoor fan motor.
- Selection tables are based on nominal airflows.
Correction factors must be applied for selection away from these conditions.
- Pipe length correction multipliers are based on horizontal pipe runs and applicable per indoor unit connected to the system.

UNIT DIMENSIONS

MRC-100AS-4

C OUTDOOR UNIT: MRC-100AS-4

NOMINAL DIMENSION (H x W x D)
= 810 x 946 x 410
USE M10 BOLT FOR FEET MOUNTING

9.85 kW
1 Phase 1 Stage

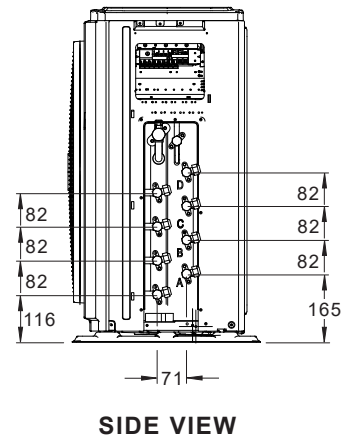
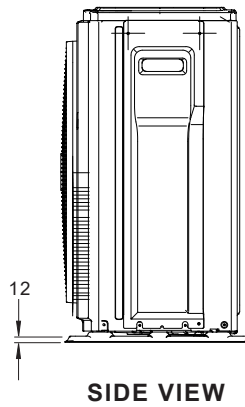
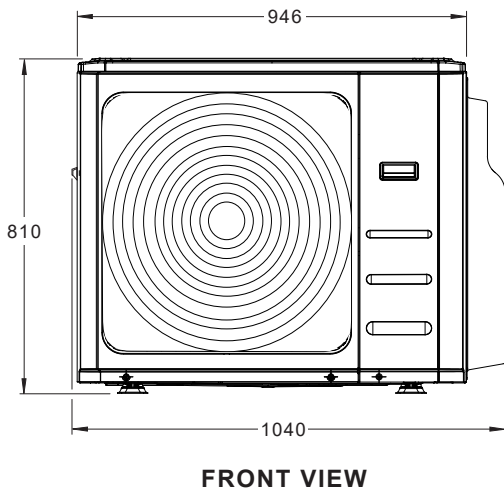
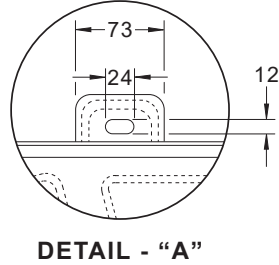
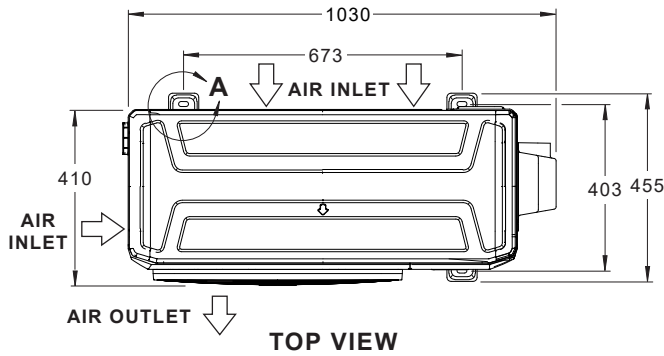

PLEASE NOTE THAT UNDER ALL CIRCUMSTANCES, CONDENSER AIR MUST NOT RECIRCULATE BACK ONTO CONDENSER COIL.

NOTES:

1. All dimensions are in mm unless specified.
2. Do not scale drawing.
3. Refer Pipe Connection Details on Specifications Sheet.
4. Suggested Service Clearances are based on conditions that the spaces are free from obstructions and walkway passage of 1000mm is available.
5. Minimum service access areas are responsibilities of the installer.

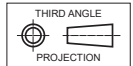

SERVICE ACCESS AREAS & AIRFLOW ALLOWANCES

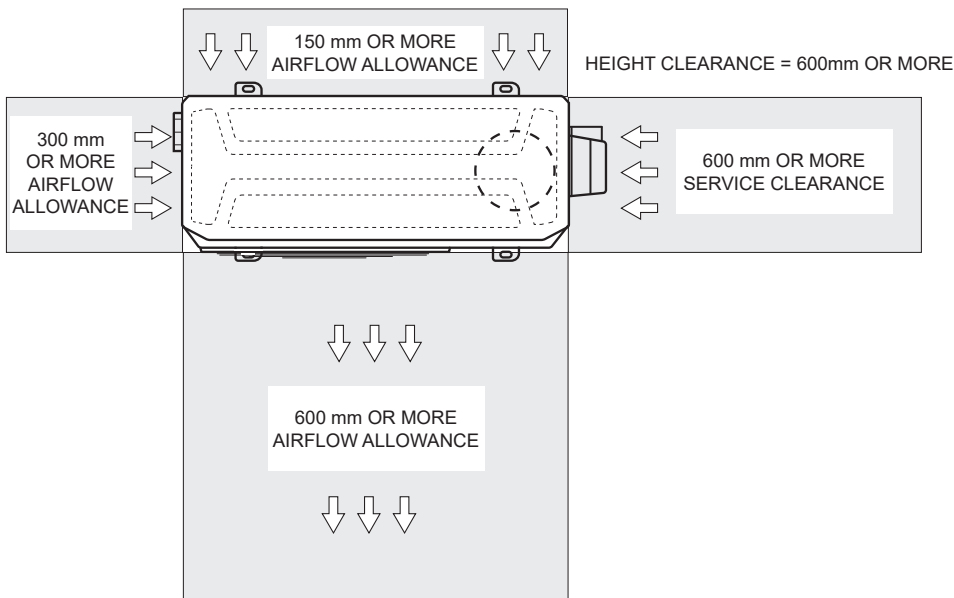

UNIT DIMENSIONS

SERENE 1 INDOOR UNITS

E INDOOR UNITS: WRE-026AS WRE-035AS WRE-050AS WRE-071AS

1 Phase
1 Stage
9.85 kW

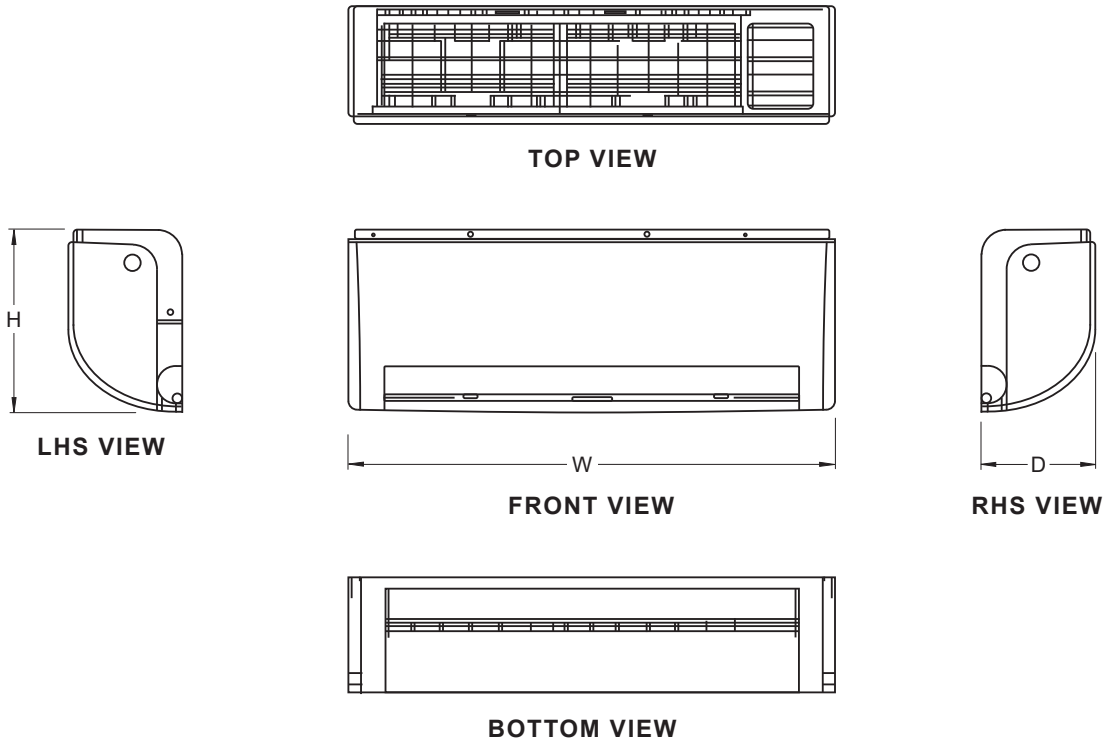

MODEL	DIMENSIONS		
	H	W	D
WRE-026AS	302	805	193
WRE-035AS	325	964	222
WRE-050AS	325	964	222
WRE-071AS	342	1106	232

SERVICE ACCESS AREAS / AIRFLOW ALLOWANCES

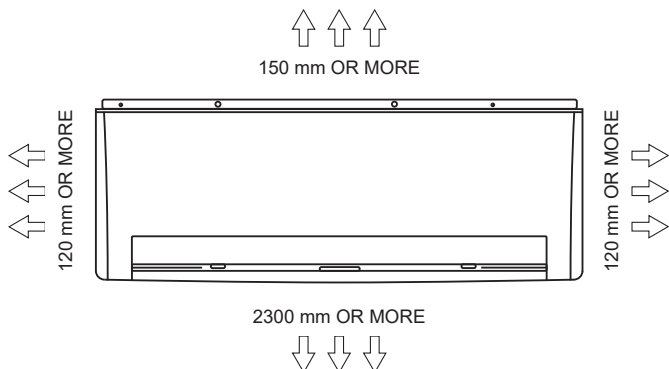

NOTES:

1. All dimensions are in mm unless specified.
2. Do not scale drawing.
3. Refer Pipe Connection Details on Specifications Sheet.
4. Minimum service access areas are responsibilities of the installer.

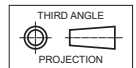

The service areas & airflow allowances mentioned are the minimum requirements to complete minor repairs. Additional space may be required should a major repair need to be undertaken.



UNIT DIMENSIONS

SERENE 2 INDOOR UNITS

E INDOOR UNITS: WRE-026CS WRE-035CS WRE-050CS WRE-072CS

9.85 kW
1 Phase 1 Stage

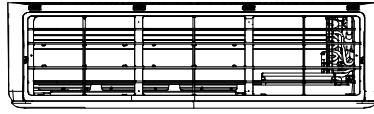

TOP VIEW

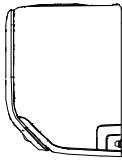

LHS VIEW

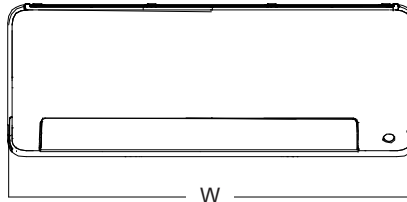

FRONT VIEW

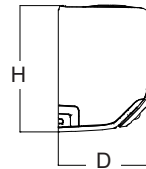

RHS VIEW

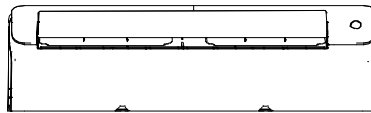

BOTTOM VIEW

MODEL	DIMENSIONS		
	H	W	D
WRE-026CS	295	795	225
WRE-035CS	295	795	225
WRE-050CS	315	965	239
WRE-072CS	370	1140	297

SERVICE ACCESS AREAS / AIRFLOW ALLOWANCES

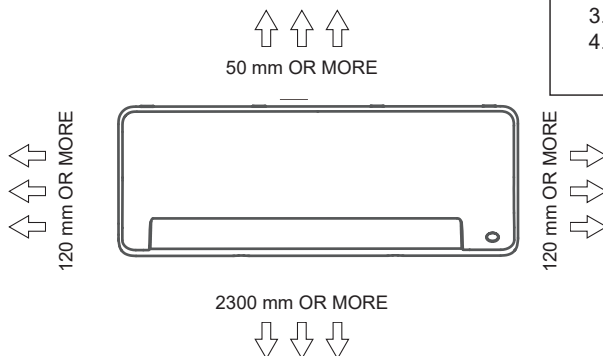

NOTES:

1. All dimensions are in mm unless specified.
2. Do not scale drawing.
3. Refer Pipe Connection Details on Specifications Sheet.
4. Minimum service access areas are responsibilities of the installer.

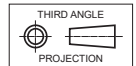

The service areas & airflow allowances mentioned are the minimum requirements to complete minor repairs. Additional space may be required should a major repair need to be undertaken.



MOUNTING DETAILS: WRE-026AS

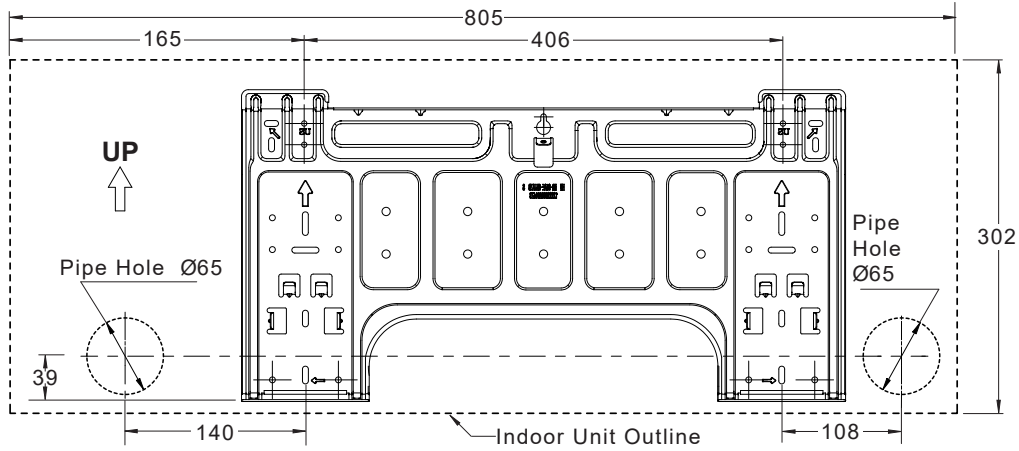

1 Phase
1 Stage
9.85 kW

MOUNTING DETAILS: WRE-035AS & WRE-050AS

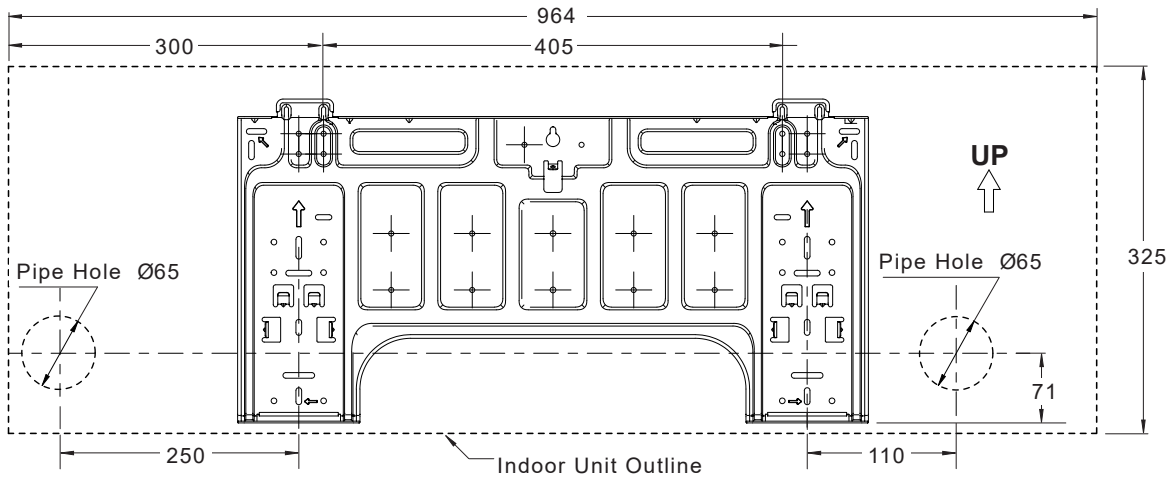

MOUNTING DETAILS: WRE-071AS

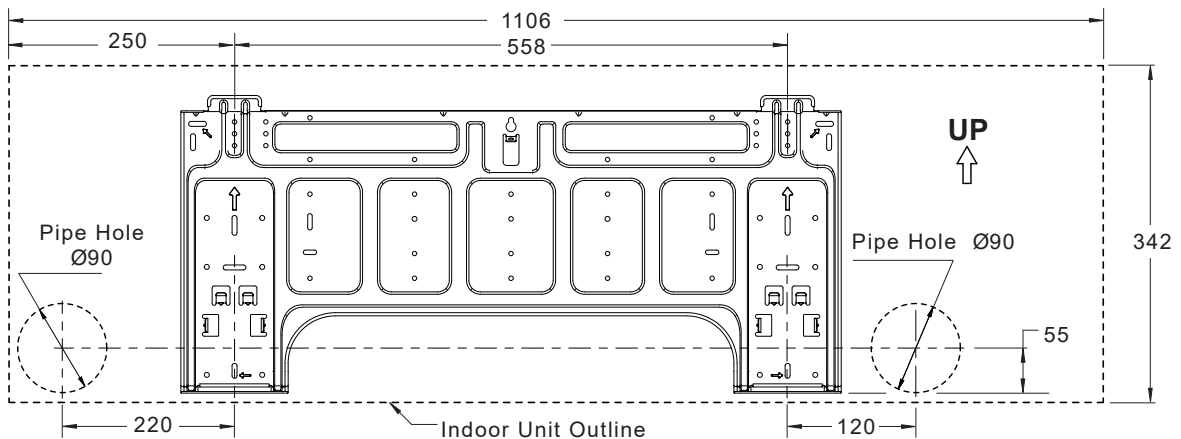

MOUNTING DETAILS: WRE-026CS AND WRE-035CS

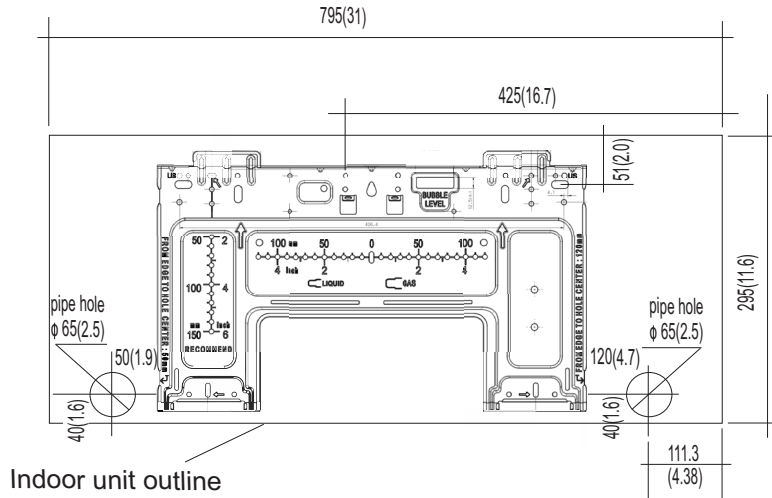

MOUNTING DETAILS: WRE-050CS

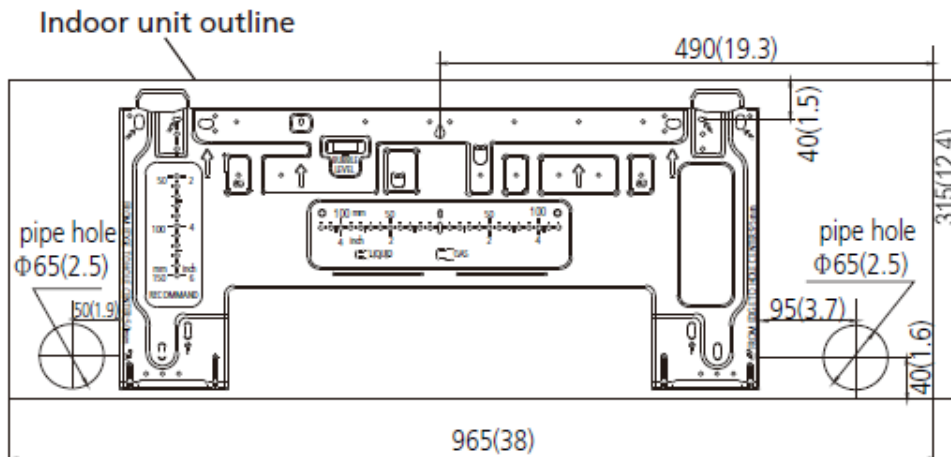

MOUNTING DETAILS: WRE-072CS

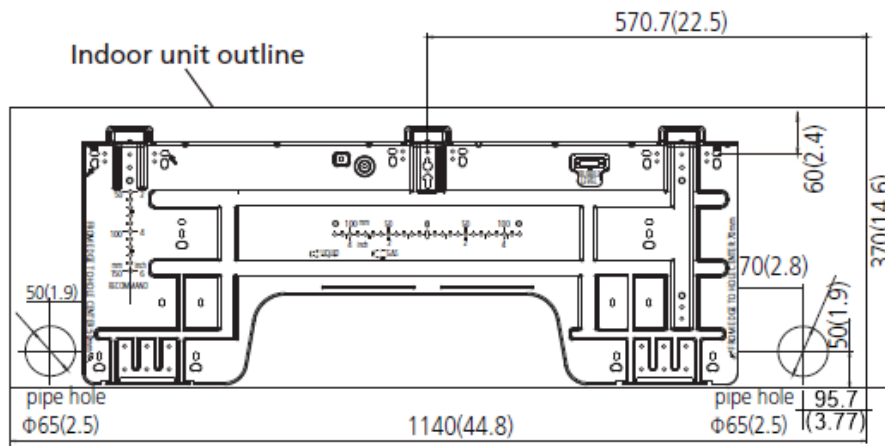

UNIT DIMENSIONS

BULKHEAD INDOOR UNITS

INDOOR UNITS: BRE-026BS BRE-035BS BRE-052BS BRE-071BS

NOTES:

1. All dimensions are in mm unless specified.
2. Do not scale drawing.
3. Refer Pipe Connection Details on Specifications Sheet.
4. Minimum service access areas are responsibilities of the installer.

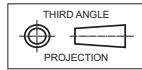

Nominal Dimensions and Supply Air Size

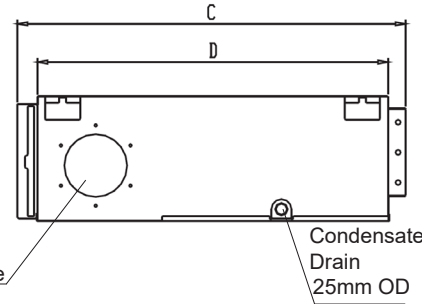
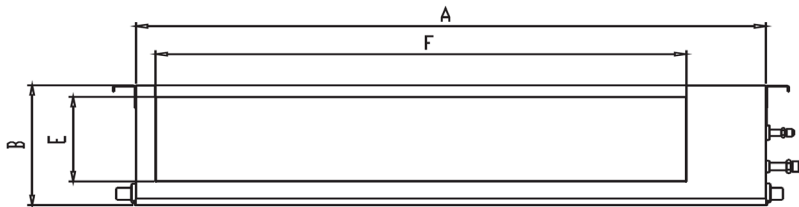

Return Air Size

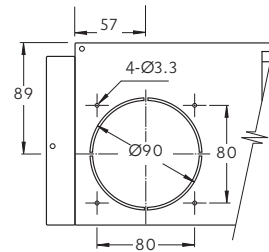
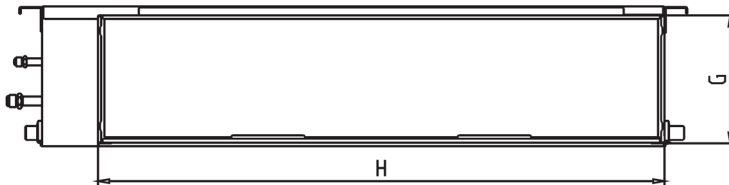

Bottom Return Air Location and Mounting Dimension

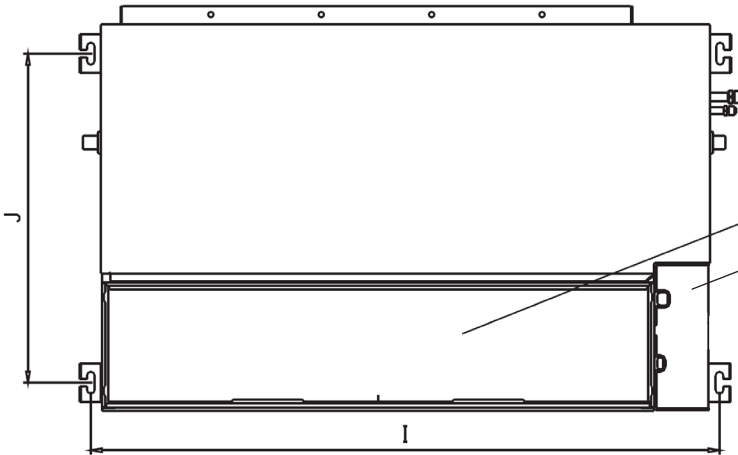

SERVICE ACCESS AREAS

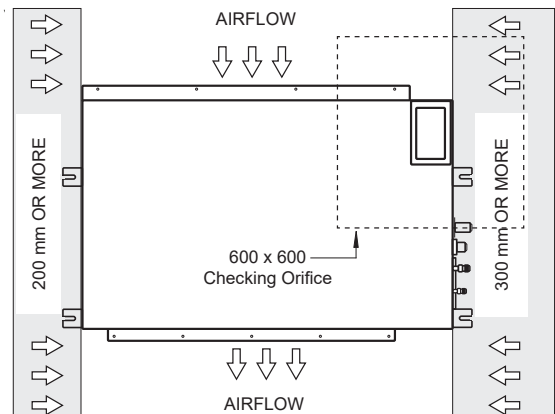

Model	Outline Dimensions				Supply Air		Return Air		Mounting	
	A	B	C	D	E	F	G	H	I	J
BRE-026BS	700	200	506	450	152	537	186	599	741	360
BRE-035BS	700	200	506	450	152	537	186	599	741	360
BRE-052BS	880	210	674	600	136	706	190	782	920	508
BRE-071BS	1100	249	774	700	175	926	228	1001	1140	607

1 Phase
1 Stage
9.85 kW

The service areas and airflow allowances mentioned are the minimum requirements to complete minor repairs. Additional space may be required should a major repair need to be undertaken.



UNIT DIMENSIONS

MINI CASSETTE INDOOR UNITS

E INDOOR UNIT: MRE-035AS MRE-050AS

OVERALL NOMINAL DIMENSION (H x W x D)
= 260 x 570 x 570
DRAIN CONNECTION = Ø25mm

NOTES:

1. All dimensions are in mm unless specified.
2. Do not scale drawing.
3. Refer Pipe Connection Details on Specifications Sheet.
4. Minimum service access areas are responsibilities of the installer.

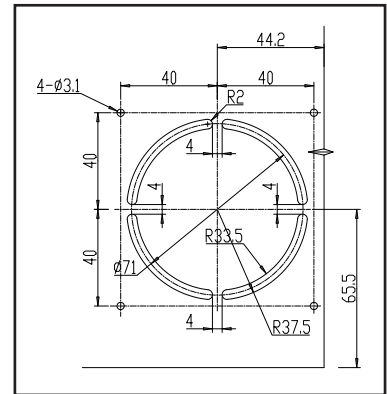
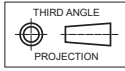

Outside Air Intake Details

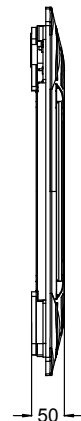
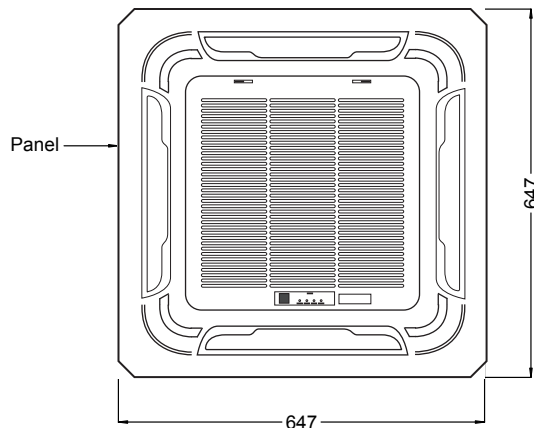
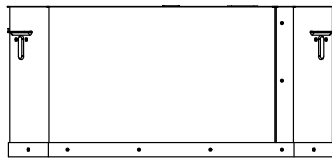
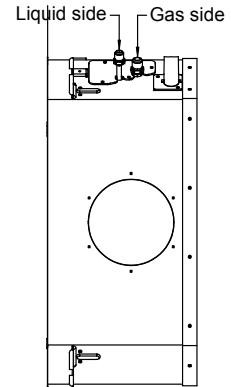
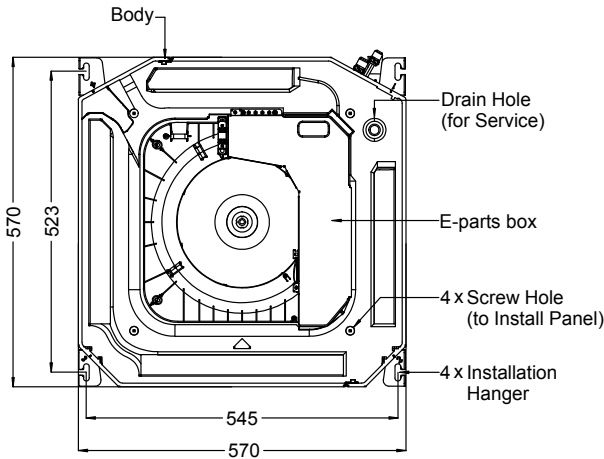
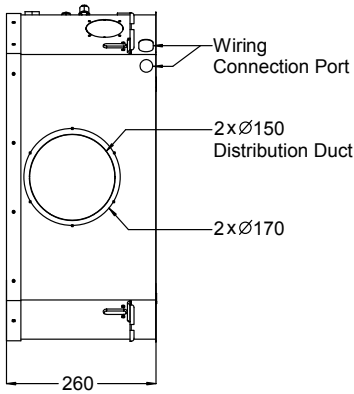
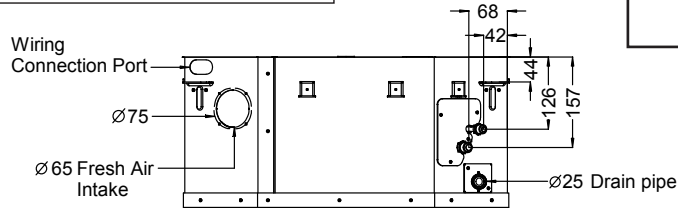

9.85 kW
1 Phase 1 Stage

SERVICE ACCESS AREAS

NOTES:

1. All dimensions are in mm unless specified.
2. Do not scale drawing.
3. Refer Pipe Connection Details on Specifications Sheet.
4. Minimum service access areas are responsibilities of the installer.

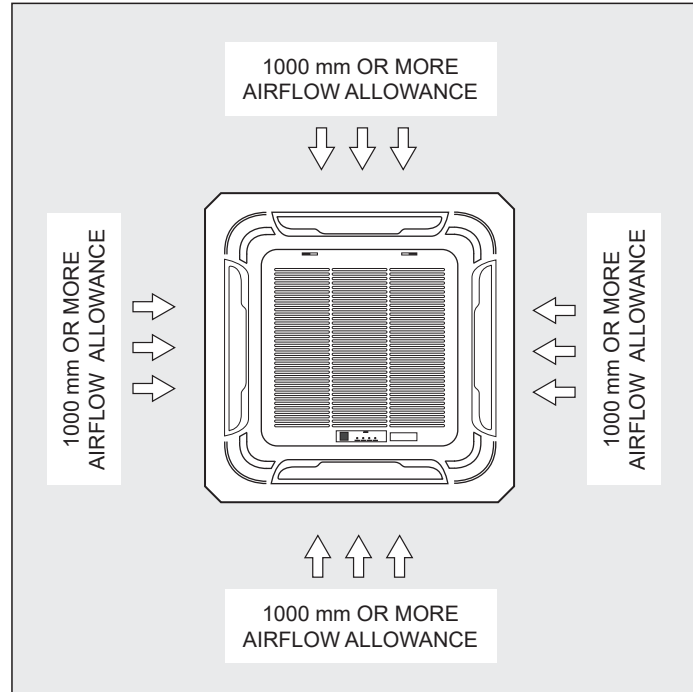
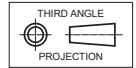

1 Phase
1 Stage
9.85 kW

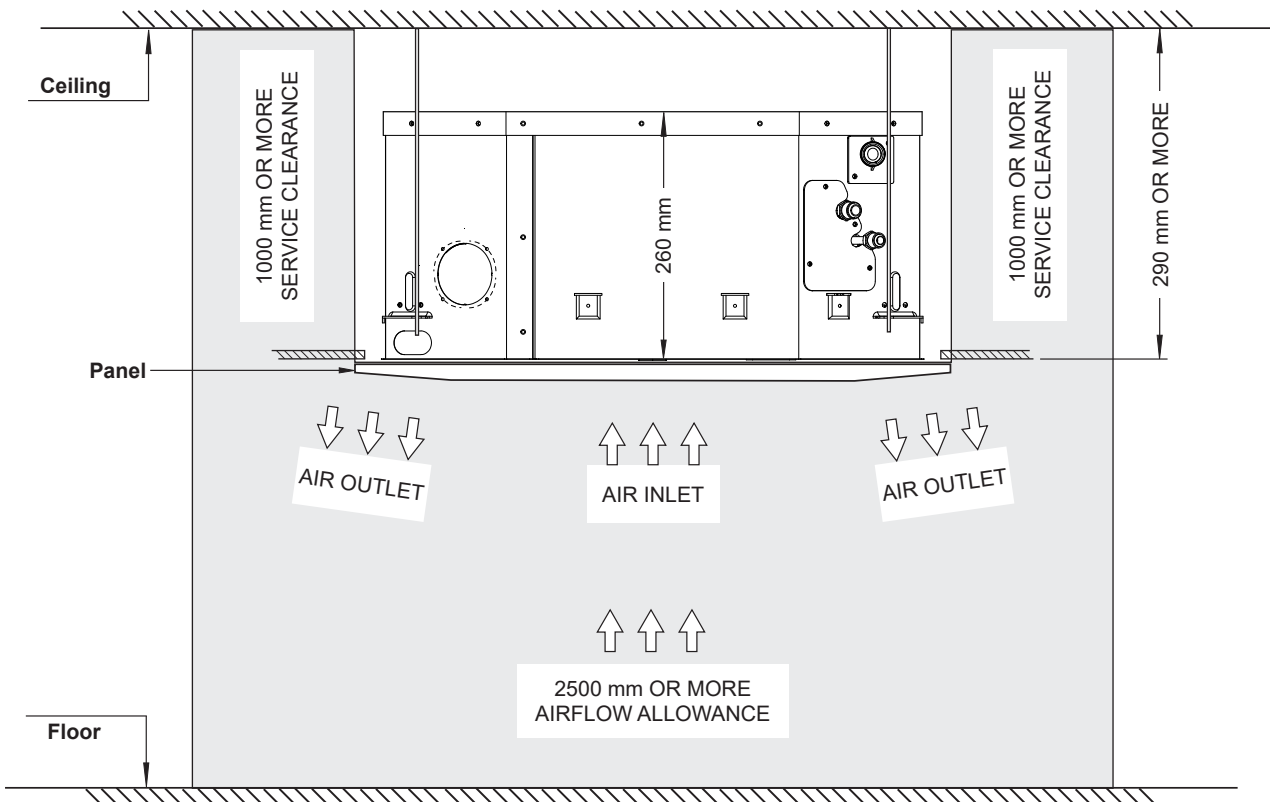

The service areas & airflow allowances mentioned are the minimum requirements to complete minor repairs. Additional space may be required should a major repair need to be undertaken.



9.85 kW
1 Phase 1 Stage

AIR VELOCITY DISTRIBUTIONS:

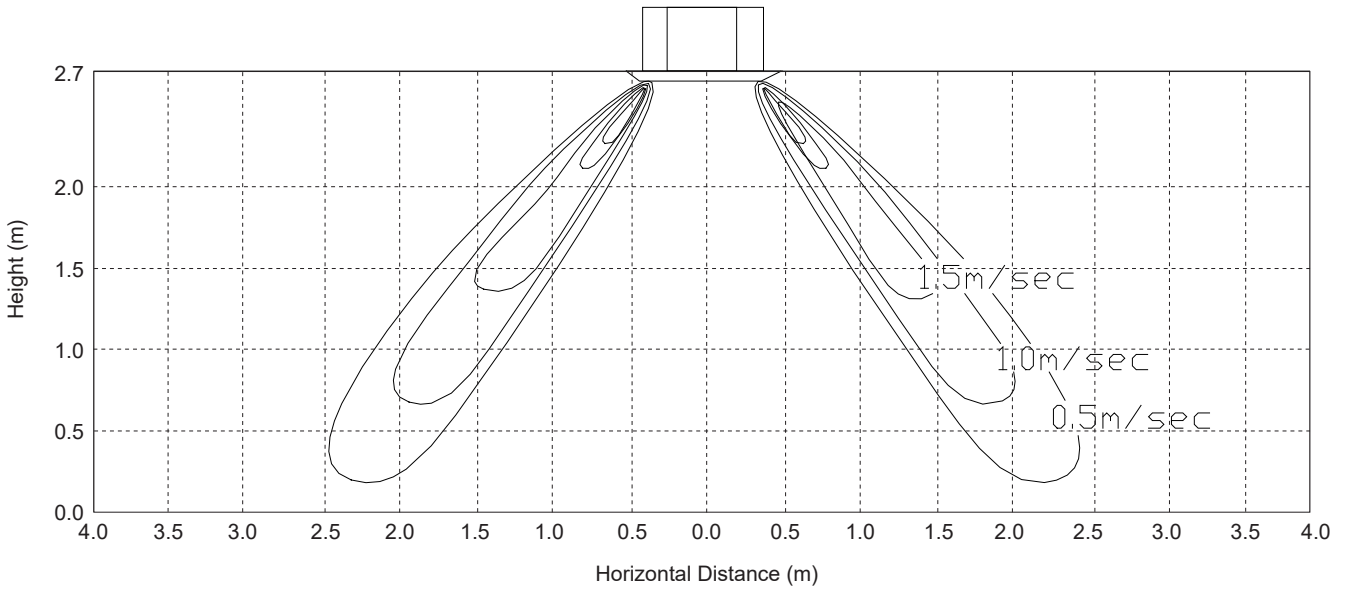

TEMPERATURE DISTRIBUTIONS:

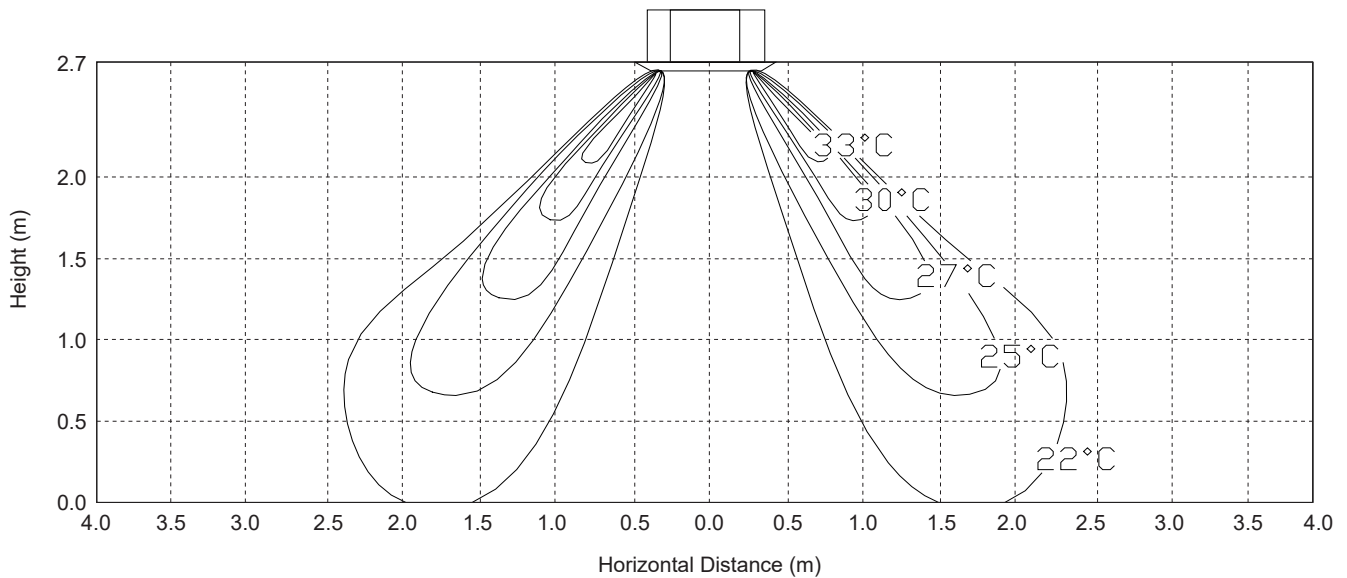

SPECIFICATIONS

MRC-100AS-4

REFRIGERATION SYSTEM	
REFRIGERANT TYPE	R-410A
FACTORY CHARGE	3300 g
PRE-CHARGE LENGTH	4 x 10 m
ADD'L. REFRIGERANT CHARGE	15 g/m
DESIGN PRESSURE (High/Low)	4.2/ 1.5 MPa

INTERCONNECTING PIPE RUN	
MAX PIPE LENGTH	60 m (Max. length for all rooms) 35 m (Max. length for 1 indoor unit)
MIN PIPE LENGTH	12 m (Min. length for 1 indoor unit)
MAX. VERTICAL LENGTH - Incl. in Max. Pipe Length	15 m (from OD unit to ID unit) 10 m (from ID unit to ID unit)

FIELD PIPE SIZES	
Liquid Pipe	6.35mm (1/4")
Gas Pipe	9.52mm (3/8") or 12.7mm (1/2")
CONNECTION TYPE	Flare Nut

ELECTRICAL		
POWER SUPPLY	220 - 240 Volts / 1 Ph + N / 50Hz	
WIRING METHOD	Hard wire to outdoor	
FULL LOAD AMPS*	Total	19.7 (MAX)
RATED LOAD AMPS**	Cooling	10.9
	Heating	11.4
IP RATING	Outdoor	IP24
	Indoor	IP20

IMPORTANT - The local electricity authority may require limits on starting current and voltage drop, please check prior to purchase.
 * Full Load Amps (FLA) shown above is based on **MAXIMUM** possible outdoor and indoor unit combinations. FLA are based on compressor and fan motors' maximum expected current. Final FLA will be based on installed combination. See wiring section of installation guide for more details.
 ** Rated Load Amps shown above is based on MEPS representative outdoor and indoor unit combinations. Rated Load Amps are measured and tested in accordance with AS/NZS3823.1.4.

CABLE SIZE & CIRCUIT BREAKER SIZE	
Suggested minimum cable size should be used as a guide only, refer to AS/NZS 3000 "Australian/New Zealand Wiring Rules" for more details. Cables and circuit breaker sizes below are based on MINIMUM possible outdoor and indoor combinations. Final sizes will be based on installed combination. See wiring section of installation guide for more details.	
Cable Size (Supply Mains)	2.5 mm ² (SUGGESTED MINIMUM)
Cable Size (Indoor to Outdoor Wire)	1.0 mm ² (2 Core + Earth)
Circuit Breaker Size	20.0Amps

OUTDOOR UNIT: MRC-100AS-4		
NOMINAL DIMENSIONS	Depth	410 mm
	Height	810 mm
	Width	946 mm
PIPE CONNECTIONS	Liquid Pipe	4 x 6.35mm (1/4")
	Gas Pipe	3 x 9.52mm (3/8") + 1 x 12.7mm (1/2")
OUTDOOR COIL		
TUBE TYPE	Copper Ø9.5mm, inner groove tube	
FIN TYPE	Hydrophylic Aluminium	
FACE AREA	0.76 m ²	
FIN SPACING	1.3 mm	
ROWS	2	
OUTDOOR FAN		
NUMBER OF FANS x TYPE	1 x Axial	
INPUT (W)	150	
AIRFLOW (l/s)	1069	

COMPRESSOR	
NUMBER PER UNIT x TYPE	1 x Twin-Rotary Compressor
STARTING METHOD	DC Inverter Starter
INPUT (W)	1955
REFRIGERANT OIL (TYPE/CHARGE)	ESTER OIL VG74 / 670ml
PROTECTION	External Thermal Cut-Out

INDOOR UNIT: WRE-026AS		
NOMINAL DIMENSIONS	Depth	193 mm
	Height	302 mm
	Width	805 mm
Nominal Weight	8.5 kg	
PIPE CONNECTIONS	Liquid Pipe	6.35mm (1/4")
	Gas Pipe	9.52mm (3/8")
INDOOR COIL		
TUBE TYPE	Copper Ø7mm, inner groove tube	
FIN TYPE	Hydrophylic Aluminium	
FACE AREA	0.163 m ²	
FIN SPACING	1.3 mm	
ROWS	2	
INDOOR FAN		
NUMBER OF FANS x TYPE	1 x Centrifugal	
INPUT (W)	88	
FULL LOAD AMPS	0.24	
AIRFLOW - Hi/ Med/ Lo	161 / 133 / 106 (l/s)	

INDOOR UNIT: WRE-035AS		
NOMINAL DIMENSIONS	Depth	222 mm
	Height	325 mm
	Width	964 mm
Nominal Weight	10.3 kg	
PIPE CONNECTIONS	Liquid Pipe	6.35mm (1/4")
	Gas Pipe	12.7mm (1/2")
INDOOR COIL		
TUBE TYPE	Copper Ø7mm, inner groove tube	
FIN TYPE	Hydrophylic Aluminium	
FACE AREA	0.22 m ²	
FIN SPACING	1.2 mm	
ROWS	2	
INDOOR FAN		
NUMBER OF FANS x TYPE	1 x Centrifugal	
INPUT (W)	110	
FULL LOAD AMPS	0.275	
AIRFLOW - Hi/ Med/ Lo	181 / 158 / 117(l/s)	

INDOOR UNIT: WRE-050AS		
NOMINAL DIMENSIONS	Depth	222 mm
	Height	325 mm
	Width	964 mm
Nominal Weight	10.4 kg	
PIPE CONNECTIONS	Liquid Pipe	6.35mm (1/4")
	Gas Pipe	12.7mm (1/2")
INDOOR COIL		
TUBE TYPE	Copper Ø7mm, inner groove tube	
FIN TYPE	Hydrophylic Aluminium	
FACE AREA	0.22 m ²	
FIN SPACING	1.2 mm	
ROWS	2	
INDOOR FAN		
NUMBER OF FANS x TYPE	1 x Centrifugal	
INPUT (W)	110	
FULL LOAD AMPS	0.275	
AIRFLOW - Hi/ Med/ Lo	306 / 264 / 211(l/s)	

1 Phase
1 Stage
9.85 kW



SPECIFICATIONS

MRC-100AS-4

9.85 kW
1 Phase 1 Stage

INDOOR UNIT: WRE-071AS		
NOMINAL DIMENSIONS	Depth	232 mm
	Height	342 mm
	Width	1106 mm
Nominal Weight		13.7 kg
PIPE CONNECTIONS	Liquid Pipe	9.52mm (3/8")
	Gas Pipe	15.9mm (5/8")
INDOOR COIL		
TUBE TYPE		Copper Ø7mm, inner groove tube
FIN TYPE		Hydrophylic Aluminium
FACE AREA		0.26 m ²
FIN SPACING		1.3 mm
ROWS		2
INDOOR FAN		
NUMBER OF FANS x TYPE		1 x Centrifugal
INPUT (W)		80
FULL LOAD AMPS		0.40
AIRFLOW - Hi / Med / Lo		386 / 356 / 242 (l/s)

INDOOR UNIT: WRE-050CS		
NOMINAL DIMENSIONS	Depth	239 mm
	Height	315 mm
	Width	965 mm
Nominal Weight		12.3 kg
PIPE CONNECTIONS	Liquid Pipe	6.35mm (1/4")
	Gas Pipe	12.7mm (1/2")
INDOOR COIL		
TUBE TYPE		Copper Ø7mm, inner groove tube
FIN TYPE		Hydrophylic Aluminium
FACE AREA		0.25 m ²
FIN SPACING		1.3 mm
ROWS		2
INDOOR FAN		
NUMBER OF FANS x TYPE		1 x Cross-flow fan
INPUT (W)		36
FULL LOAD AMPS		0.275
AIRFLOW - Boost / Hi / Med / Lo		240 / 201 / 172 / 120 (l/s)

INDOOR UNIT: WRE-026CS		
NOMINAL DIMENSIONS	Depth	225 mm
	Height	295 mm
	Width	795 mm
Nominal Weight		10.3 kg
PIPE CONNECTIONS	Liquid Pipe	6.35mm (1/4")
	Gas Pipe	9.52mm (3/8")
INDOOR COIL		
TUBE TYPE		Copper Ø7mm, inner groove tube
FIN TYPE		Hydrophylic Aluminium
FACE AREA		0.20 m ²
FIN SPACING		1.3 mm
ROWS		2
INDOOR FAN		
NUMBER OF FANS x TYPE		1 x Cross-flow fan
INPUT (W)		50
FULL LOAD AMPS		0.24
AIRFLOW - Boost / Hi / Med / Lo		250 / 180 / 120 / 100 (l/s)

INDOOR UNIT: WRE-072CS		
NOMINAL DIMENSIONS	Depth	297 mm
	Height	370 mm
	Width	1140 mm
Nominal Weight		19.7 kg
PIPE CONNECTIONS	Liquid Pipe	9.52mm (3/8")
	Gas Pipe	15.9mm (5/8")
INDOOR COIL		
TUBE TYPE		Copper Ø7mm, inner groove tube
FIN TYPE		Hydrophylic Aluminium
FACE AREA		0.55 m ²
FIN SPACING		1.3 mm
ROWS		2
INDOOR FAN		
NUMBER OF FANS x TYPE		1 x Cross-flow fan
INPUT (W)		58
FULL LOAD AMPS		0.40
AIRFLOW - Boost / Hi / Med / Lo		370 / 320 / 230 / 190 (l/s)

INDOOR UNIT: WRE-035CS		
NOMINAL DIMENSIONS	Depth	225 mm
	Height	295 mm
	Width	795 mm
Nominal Weight		10.3 kg
PIPE CONNECTIONS	Liquid Pipe	6.35mm (1/4")
	Gas Pipe	9.52mm (3/8")
INDOOR COIL		
TUBE TYPE		Copper Ø7mm, inner groove tube
FIN TYPE		Hydrophylic Aluminium
FACE AREA		0.43 m ²
FIN SPACING		1.3 mm
ROWS		2
INDOOR FAN		
NUMBER OF FANS x TYPE		1 x Cross-flow fan
INPUT (W)		50
FULL LOAD AMPS		0.275
AIRFLOW - Boost / Hi / Med / Lo		250 / 180 / 120 / 100 (l/s)

INDOOR UNIT: BRE-026BS		
NOMINAL DIMENSIONS	Depth	506 mm
	Height	200 mm
	Width	700 mm
Nominal Weight		18.0 kg
PIPE CONNECTIONS	Liquid Pipe	6.35mm (1/4")
	Gas Pipe	9.52mm (3/8")
INDOOR COIL		
TUBE TYPE		Copper Ø7mm, inner groove tube
FIN TYPE		Hydrophylic Aluminium
FACE AREA		0.11 m ²
FIN SPACING		1.4 mm
ROWS		3
INDOOR FAN		
NUMBER OF FANS x TYPE		1 x Centrifugal
INPUT (W)		55
FULL LOAD AMPS		1.2
AIRFLOW - Hi / Med / Lo		167 / 150 / 128 (l/s)
EXTERNAL STATIC PRESS RANGE (Pa)		0 - 60



SPECIFICATIONS

MRC-100AS-4

1 Phase
1 Stage
9.85 kW

INDOOR UNIT: BRE-035BS		
NOMINAL DIMENSIONS	Depth	506 mm
	Height	200 mm
	Width	700 mm
Nominal Weight		18.0 kg
PIPE CONNECTIONS	Liquid Pipe	6.35mm (1/4")
	Gas Pipe	9.52mm (3/8")
INDOOR COIL		
TUBE TYPE		Copper Ø7mm, inner groove tube
FIN TYPE		Hydrophilic Aluminium
FACE AREA		0.11 m ²
FIN SPACING		1.4 mm
ROWS		3
INDOOR FAN		
NUMBER OF FANS x TYPE		1 x Centrifugal
INPUT (W)		55
FULL LOAD AMPS		1.2
AIRFLOW - Hi / Med / Lo		172 / 156 / 139 (l/s)
EXTERNAL STATIC PRESS RANGE (Pa)		0 - 60

INDOOR UNIT: MRE-035AS		
NOMINAL DIMENSIONS	Depth	570 mm
	Height	570 mm
	Width	570 mm
Nominal Weight		19 kg
PIPE CONNECTIONS	Liquid Pipe	6.35mm (1/4")
	Gas Pipe	9.52mm (3/8")
INDOOR COIL		
TUBE TYPE		Copper Ø7mm, inner groove tube
FIN TYPE		Hydrophilic Aluminium
FACE AREA		0.286 m ²
FIN SPACING		1.3 mm
ROWS		2
INDOOR FAN		
NUMBER OF FANS x TYPE		1 x Centrifugal
INPUT (W)		46
FULL LOAD AMPS		0.57
AIRFLOW - Hi / Med / Lo		181 / 147 / 125 (l/s)

INDOOR UNIT: BRE-052BS		
NOMINAL DIMENSIONS	Depth	674 mm
	Height	210 mm
	Width	880 mm
Nominal Weight		23 kg
PIPE CONNECTIONS	Liquid Pipe	6.35mm (1/4")
	Gas Pipe	12.7mm (1/2")
INDOOR COIL		
TUBE TYPE		Copper Ø7mm, inner groove tube
FIN TYPE		Hydrophilic Aluminium
FACE AREA		0.175 m ²
FIN SPACING		1.4 mm
ROWS		3
INDOOR FAN		
NUMBER OF FANS x TYPE		1 x Centrifugal
INPUT (W)		90
FULL LOAD AMPS		1.5
AIRFLOW - Hi / Med / Lo		236 / 219 / 181 (l/s)
EXTERNAL STATIC PRESS RANGE (Pa)		0 - 100

INDOOR UNIT: MRE-050AS		
NOMINAL DIMENSIONS	Depth	570 mm
	Height	260 mm
	Width	570 mm
Nominal Weight		19 kg
PIPE CONNECTIONS	Liquid Pipe	6.35mm (1/4")
	Gas Pipe	12.7mm (1/2")
INDOOR COIL		
TUBE TYPE		Copper Ø7mm, inner groove tube
FIN TYPE		Hydrophilic Aluminium
FACE AREA		0.286 m ²
FIN SPACING		1.3 mm
ROWS		2
INDOOR FAN		
NUMBER OF FANS x TYPE		1 x Centrifugal
INPUT (W)		46
FULL LOAD AMPS		0.57
AIRFLOW - Hi / Med / Lo		189 / 156 / 139 (l/s)

INDOOR UNIT: BRE-071BS		
NOMINAL DIMENSIONS	Depth	774 mm
	Height	249 mm
	Width	1100 mm
Nominal Weight		30.2 kg
PIPE CONNECTIONS	Liquid Pipe	9.52mm (3/8")
	Gas Pipe	15.9mm (5/8")
INDOOR COIL		
TUBE TYPE		Copper Ø7mm, inner groove tube
FIN TYPE		Hydrophilic Aluminium
FACE AREA		0.27 m ²
FIN SPACING		1.4 mm
ROWS		3
INDOOR FAN		
NUMBER OF FANS x TYPE		1 x Centrifugal
INPUT (W)		90
FULL LOAD AMPS		1.5
AIRFLOW - Hi / Med / Lo		361 / 333 / 250 (l/s)
EXTERNAL STATIC PRESS RANGE (Pa)		1 - 160

ELECTRIC CONTROLS	
DEFROST METHOD	Reverse Cycle
CONTROL FIELD WIRING - OUTDOOR TO INDOOR (FIELD SUPPLIED)	2 Core 14 / 0.20 (0.44mm ²) Shielded Data Cable
WALL CONTROLLER CABLE (INCLUDED WITH WALL CONTROLLER)	4 Core (0.75mm ²) Shielded Data Cable

OPERATING RANGE			
It is essential that the unit is correctly sized for the application and operates within its recommended range of operating conditions as shown below.			
MODE	RANGE	INDOOR OPERATING TEMPERATURE	OUTDOOR AIR INTAKE TEMPERATURE
COOLING	Max.	32°C DB	50°C DB
	Min.	17°C DB	-15°C DB
HEATING	Max.	30°C DB	30°C DB
	Min.	0°C DB	-25°C DB

AIR FILTERS

All return air including fresh air must have adequate filter supplied and fitted by installing contractor. Filters must be always accessible for cleaning. For bulkhead models (BRE), ActronAir does not supply or make any provisions for return air filter.



WIRING DIAGRAM

MRC-100AS-4

9.85 kW
1 Phase **1 Stage**

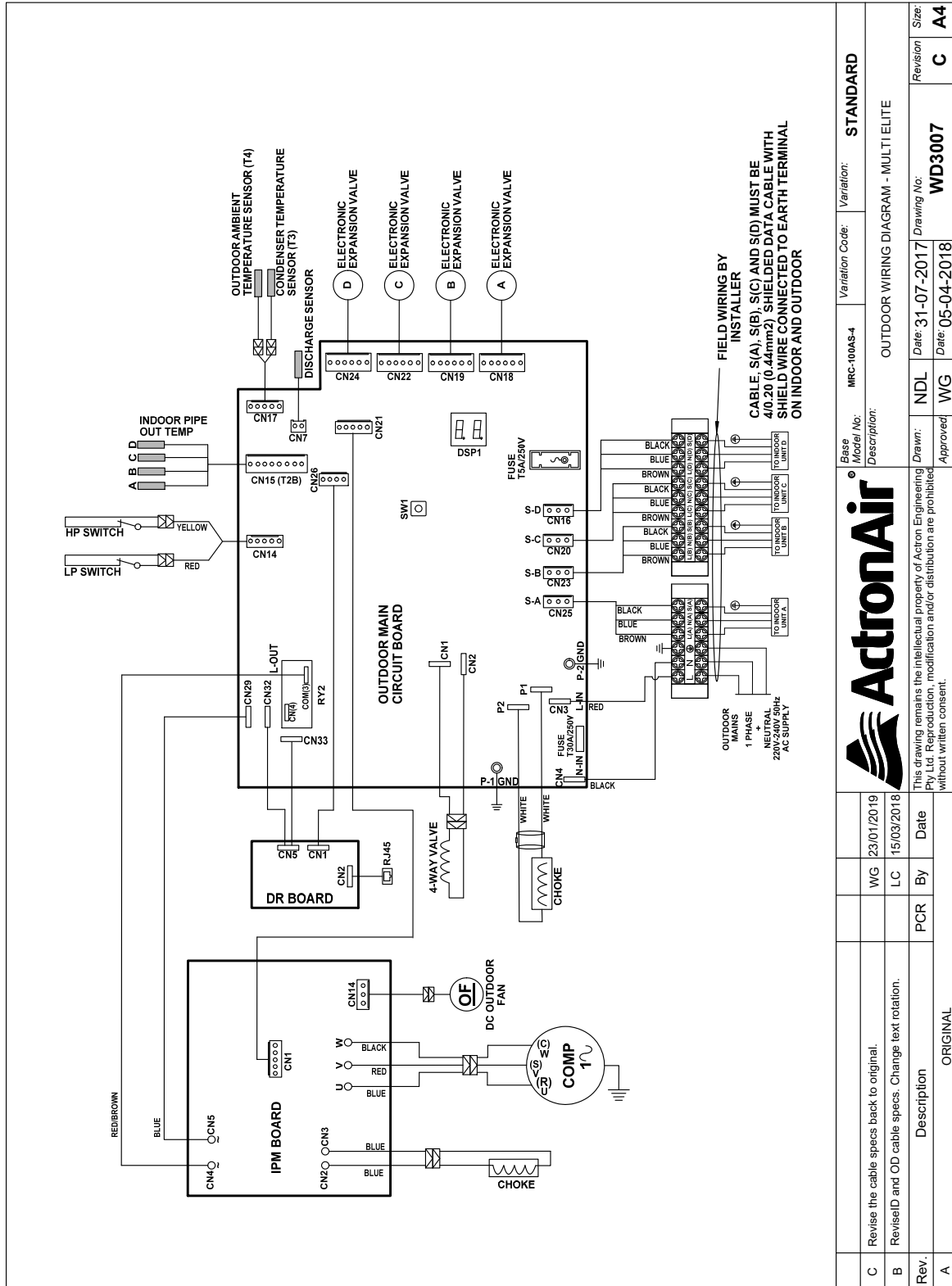

Base Model No:	MRC-100AS-4	Variation Code:	STANDARD
Description:	OUTDOOR WIRING DIAGRAM - MULTI ELITE		
Drawn:	NDL	Date:	31-07-2017
Approved:	WG	Date:	05-04-2018
Drawing No:	WD3007		
Revision:	C	Size:	A4

This drawing remains the intellectual property of Actron Engineering Pty Ltd. Reproduction, modification and/or distribution are prohibited without written consent.



WIRING DIAGRAM MINI CASSETTE / SERENE 1 INDOOR UNIT

MINI CASSETTE (INDOOR)

1 Phase
1 Stage
9.85 kW

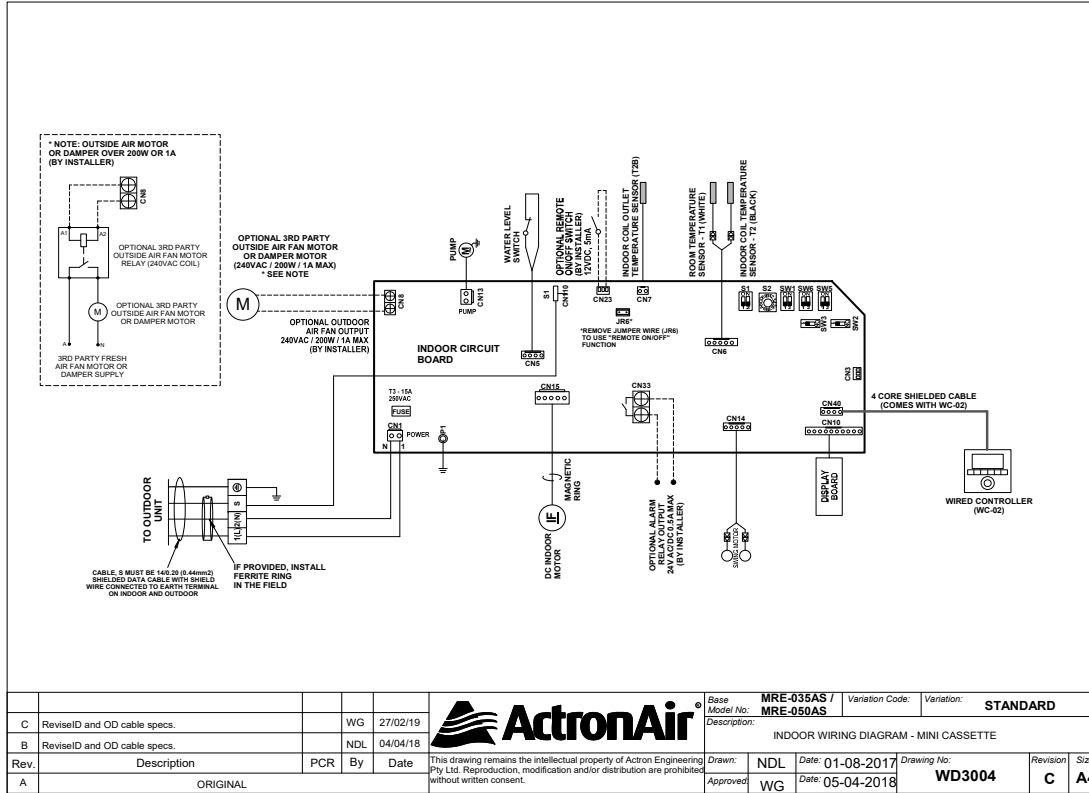

SERENE 1 (INDOOR)

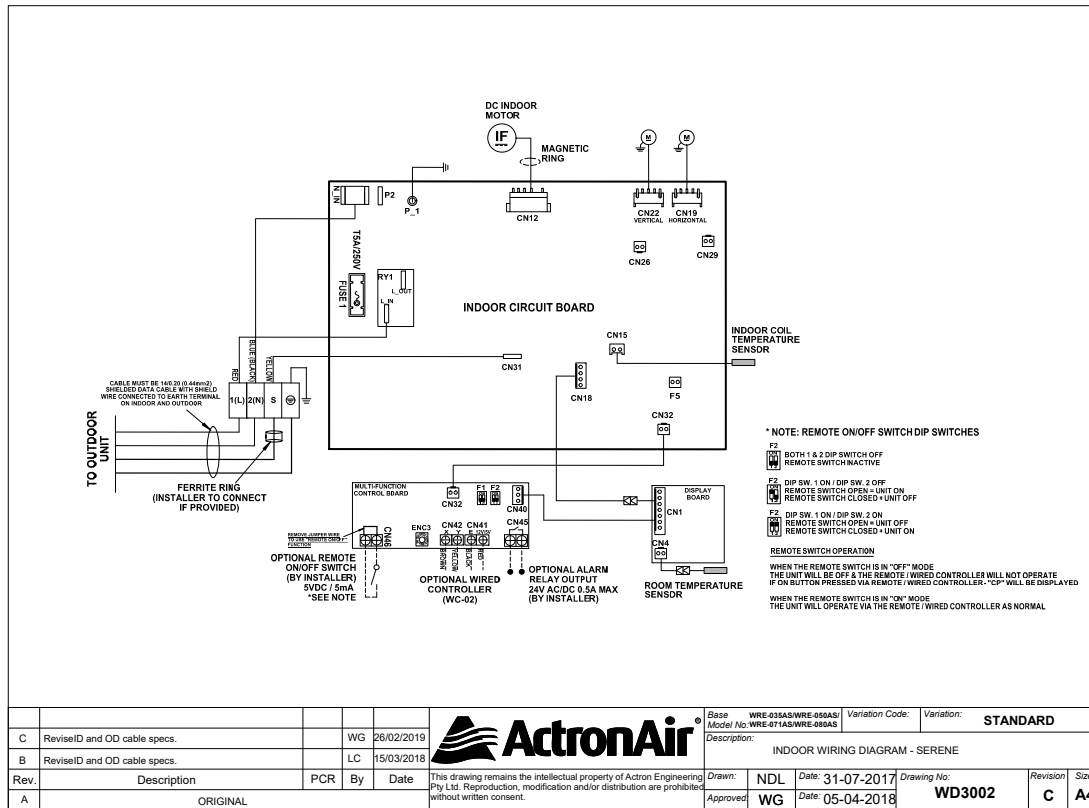

WIRING DIAGRAM

SERENE 2 INDOOR UNIT / BULKHEAD INDOOR UNIT

SERENE 2 (INDOOR)

9.85 kW
1 Phase 1 Stage

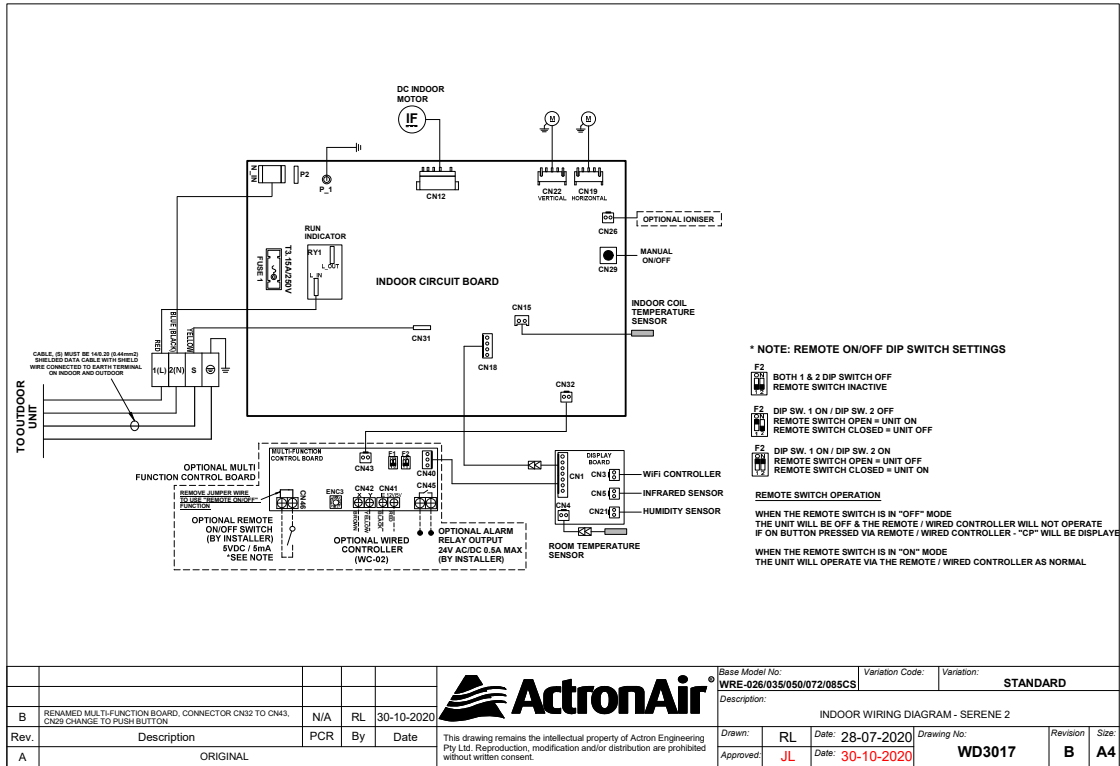

BULKHEAD (INDOOR)

