

# Package Tri-Capacity

## Installation and Commissioning Guide

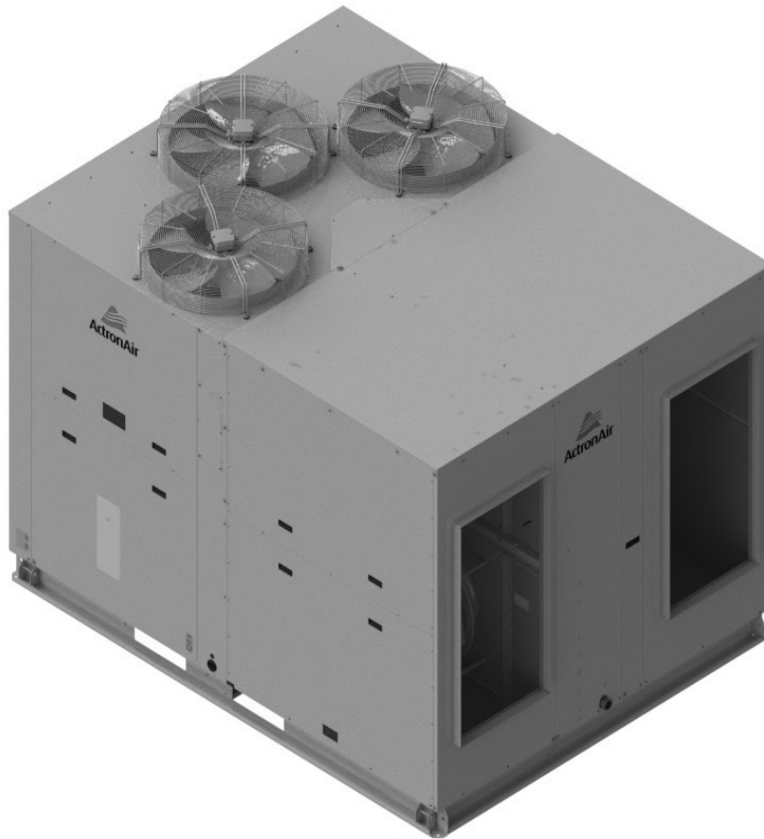

### Model Numbers

PKY820T  
PKY960T

#### **IMPORTANT NOTE:**

Please read this manual carefully before installing or operating your air conditioning unit.



*That's better. That's Actron.*

## Table of Contents

<b>01. SAFETY PRECAUTIONS.....</b>	<b>04</b>
<b>02. UNPACKING AND INSPECTION.....</b>	<b>04</b>
<b>03. UNIT MOUNTING AND LOCATION .....</b>	<b>04</b>
<b>04. COMPONENTS OVERVIEW.....</b>	<b>05</b>
<b>05. UNIT DIMENSIONS.....</b>	<b>06</b>
05.01. PKY820T	06
05.02. PKY960T	07
05.03. Service Access Areas and Airflow Clearances	08
<b>06. UNIT LIFTING PROCEDURES .....</b>	<b>09</b>
06.01. Crane Lifting Method	09
06.02. Fork Lifting Method	10
<b>07. CONDENSATE AND SAFETY TRAY DRAINAGE INSTRUCTIONS .....</b>	<b>11</b>
07.01. Suggested Minimum Slope To Ensure Correct Drainage	11
07.02. Suggested Drain Trap Details	11
<b>08. BANKING OF UNITS.....</b>	<b>12</b>
08.01. End-To-End Configuration	12
08.02. Cluster Configuration	12
08.03. Side-By-Side Configuration	13
08.04. End-To-End Configuration (With Optional Hood) ***	13
08.05. Side-By-Side Configuration	14
08.06. End-To-End Configuration (With Optional Hood) ***	14
<b>09. PARTS LAYOUT .....</b>	<b>15</b>
09.01. PKY820T / PKY960T	15
09.02. PKY820T / PKY960T	15
09.03. PKY820T / PKY960T	16
09.04. PKY820T / PKY960T	16
09.05. PKY820T / PKY960T	17
09.06. PKY820T / PKY960T	17
<b>10. UNIT PREPARATION .....</b>	<b>18</b>
10.01. Supply and Return Angle Plate Installation	18
10.02. Supply and Return Angle Plate Assembly / Installation	19
10.03. Electrical Mains and Isolator Installation	20
10.04. Compressor Shipping Blocks Removal	21
10.05. Air Filter Installation	22
<b>11. ELECTRICAL .....</b>	<b>23</b>
11.01. Package Electrical Connection	23
11.02. Maximum Cable Lengths	24
11.03. BMS Control Installation Procedures	25
11.05. Demand Response Management	27
<b>12. CONTROL MENU .....</b>	<b>28</b>
12.01. Menu Navigation	28
<b>13. MENU TREE .....</b>	<b>29</b>
13.01. Main / Status Menu	29
13.02. Service Menu	30
13.03. Manufacturer Menu	32

<b>14. EXTERNAL INPUT OPERATION .....</b>	<b>34</b>
14.01. Unit ON/OFF Configuration	34
14.02. Indoor Fan External Control	34
14.03. Compressor Configuration	36
<b>15. INTERNAL SENSOR OPERATION.....</b>	<b>39</b>
15.01. Unit Control Configuration	39
15.02. Unit ON/OFF Configuration	39
15.03. Indoor Fan Configuration	42
<b>16. SETTING UP BMS (REMOTE DEMAND) OPTIONAL .....</b>	<b>42</b>
<b>17. SETTING ECONOMY CYCLE OPERATION .....</b>	<b>42</b>
17.01. Setting Economy Cycle Type	43
17.02. Calibration Damper Opening	44
<b>18. ROOM AIR TEMPERATURE SENSOR INSTALLATION.....</b>	<b>45</b>
18.01. Package Unit Air Temperature Sensor	45
<b>19. ROOM AIR TEMPERATURE SETUP IN CONTROL INTERFACE .....</b>	<b>46</b>
19.01. Averaging Four Room Air Temperature Sensors (Optional)	46
19.03. Room Temperature Sensor Adjustment Instructions	47
<b>20. AFTER HOURS LOGIC WITH TIMECLOCK (SCHEDULER) .....</b>	<b>47</b>
20.01. After Hours wiring to the unit	47
20.02. Operational Logic	47
<b>21. ENABLE / DISABLE AIR FILTER ALARM .....</b>	<b>48</b>
<b>22. EXTERNAL INPUT WIRING DIAGRAMS.....</b>	<b>49</b>
22.01. 24VAC Relay Output Compressors and Indoor Fans	49
22.02. 0-10 Analogue Output Compressor and 24VAC Relay Output Indoor Fans	50
22.03. 24VAC Relay Output Compressor and 0-10 Analogue Output Indoor Fans	51
22.04. Wiring Diagram 0-10 Analogue Output Compressors and Indoor Fans	52
<b>23. FAN PERFORMANCE DATA AND CURVE .....</b>	<b>53</b>
<b>24. REFRIGERANT CHARGING .....</b>	<b>55</b>
24.01. Charging Method 1: Subcooling and Superheat	55
24.02. Charging Method 2: Cooling Charging Curve	60
24.03. Thermal Expansion Valve (TXV) Adjustment	61
<b>25. FAULT DISPLAY CODES.....</b>	<b>62</b>
25.01. Control Fault Code Displays	62
25.02. Soft Starter Display Codes	62
<b>26. TROUBLESHOOTING GUIDE .....</b>	<b>63</b>
<b>27. MAINTENANCE.....</b>	<b>64</b>
<b>28. MAINTENANCE FREQUENCY CHECKLIST .....</b>	<b>66</b>
<b>29. SENSORS DETAIL.....</b>	<b>68</b>
<b>30. KEY PARTS LIST .....</b>	<b>69</b>
<b>31. START-UP AND COMMISSIONING REPORT.....</b>	<b>70</b>

## 01. SAFETY PRECAUTIONS

1. To ensure proper equipment operation, read all instructions thoroughly before proceeding with installation. Failure to do so may result in damage to the unit and void your warranty.
2. Installation must be carried out by qualified technician\*.
3. Installer must incorporate a means of electrical disconnection (isolator) in the sub mains fixed wiring in accordance with AS/NZS 3000:2018 (also known as Australian Wiring Rules).
4. Ensure that unit installation complies with relevant council regulations and building code standards.
5. All electrical wiring must be in accordance with current electrical authority regulations and all wiring connections to be as per electrical diagram provided.
6. This unit is fitted with EC Motors with high power capacitors, which can have dangerous voltages at terminals for up to 5 minutes after main power has been isolated. Wait at least 5 minutes after power isolation and test for high voltage before performing service work.
7. EC Plug Fan fitted to this unit has dual power supplies, i.e. 415V/3Ph/50Hz motor power supply plus 10VDC control power supply. Care must be taken to ensure both are safely isolated to prevent personal injury and damage to the equipment.
8. Beware of rotating fans. Long hair, dangling items, such as clothing and jewellery could become entangled and pulled into the device.
9. Always use PPE for safety and protection.
10. Make sure that safety guards and panel covers are always firmly secured and not damaged.
11. This appliance is not intended for use by young children or infirm person unless they have been adequately supervised by a responsible person to ensure that they can use the appliance safely. Young children should be supervised to ensure that they do not play with the appliance.
12. WH&S rules and regulations must be observed and will take precedent during installation process.

\*Qualifications required will be appropriate Electrical, Refrigeration and Refrigerant Handling License and Training, dependent on local State/Territory regulations.

## 02. UNPACKING AND INSPECTION

1. Remove the packaging around the unit.
2. Remove anchor bolts between the unit and the pallet.
3. Check the unit components for any sign of transport damage:
  - Check for obvious panel dents.
  - Check for any dents or breakage in propeller and blower fan.
  - Conduct pull test on all wire terminals.
  - Check for loosened screws.

If there is any damage to the unit contact ActronAir Customer Care Department immediately on number: **1300 522 722**.

## 03. UNIT MOUNTING AND LOCATION

1. The units must be installed in accordance with relevant authority regulations.
2. Install the unit on a level and strong foundation.
3. Install anti-vibration rubber or isolation mounts (installer to supply) under **all of the unit's feet** to help reduce noise and minimize vibration transfer through the foundation. Ensure that all anti-vibration rubbers are rated to provide stable support without impairing the unit's structural integrity.
4. Diameter or width of anti-vibration rubber's must be at least equal to the width of the actual feet to prevent deformation overtime.
5. Level the unit to ensure good condensate drainage away from the unit.
6. Ample service access areas and minimum space allowance for airflow must be provided.
7. Avoid installing the unit in such a place where there is danger of fire due to leakage of inflammable fluid.
8. Ensure that the spaces around the unit are free from any obstructions for optimum unit performance.

## 04.COMPONENTS OVERVIEW

### Package Unit

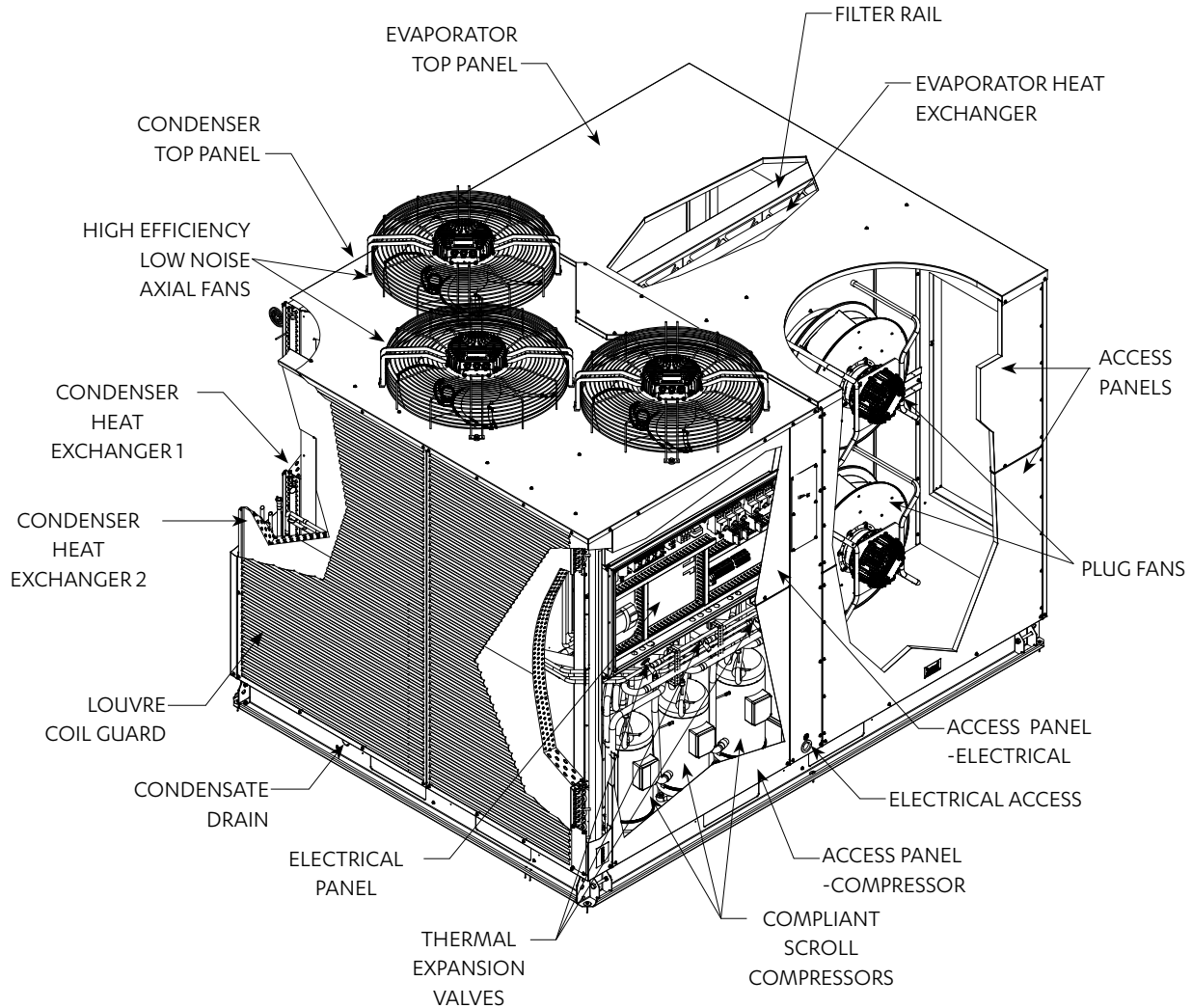

#### NOTE

\* Isolator Switch needs to be assembled and installed in the field. Components are packed separately and located inside control box.

# 05. UNIT DIMENSIONS

## 05.01. PKY820T

DIMENSION (H x W x L) = 2155 x 2250 x 2920  
 SUPPLY DUCT (H x W) = 1200 x 600  
 RETURN DUCT (H x W) = 1200 x 600

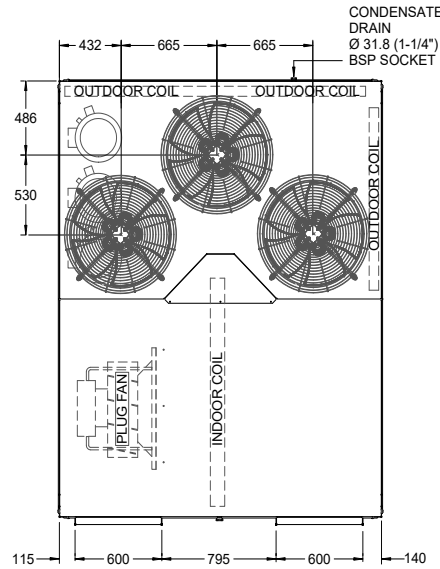
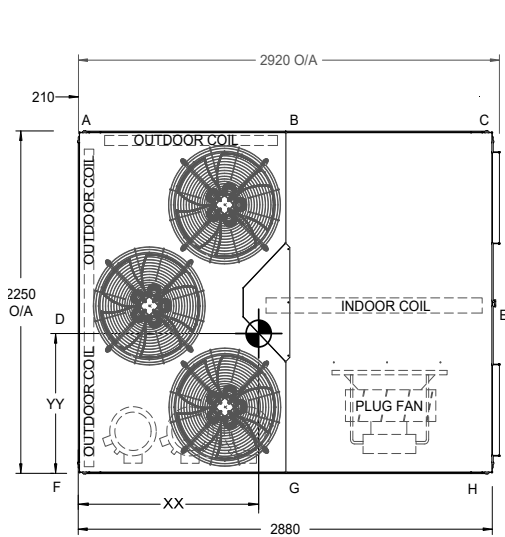
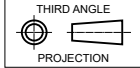

TOP VIEW

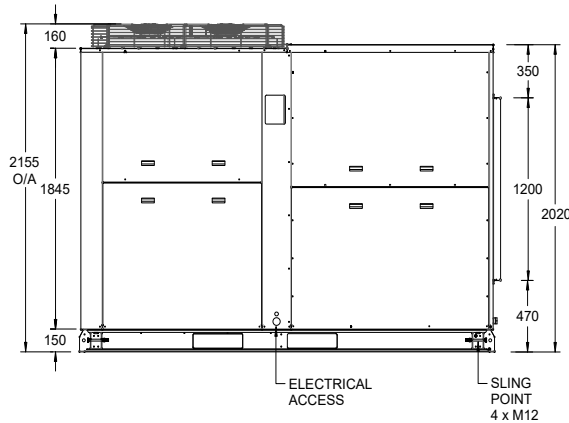

SIDE VIEW

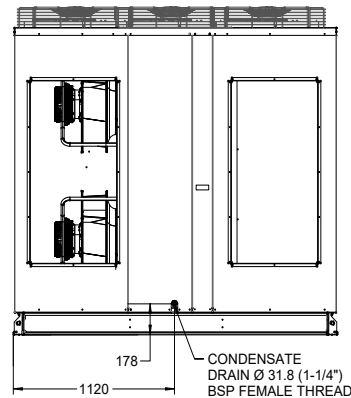

FRONT VIEW

Unit Air Handling Configuration (LH / RH)	Unit Weight (kg)	Corner Weights (kg)								Centre of Gravity Position	
		A	B	C	D	E	F	G	H	XX	YY
Left Handing	1263	118	232	26	77	201	222	315	72	1272	927
Right Handing	1263	118	260	53	77	201	222	288	44	1249	1045

**NOTES:**

- Do not scale drawing. All dimensions are in mm unless specified. Refer to corresponding unit dimensional drawing for mounting hole details.
- LH/RH refers to Left Hand or Right Hand location of supply air.
- Service Access Areas and Spaces for Airflow Clearances given above are suggested minimum based on the condition that the spaces around the units are free from any obstructions and a walkway passage of 1000 mm between the units or between the unit and the outside perimeter is available.
- Minimum service access areas and spaces for airflow clearances are responsibilities of the installer, ActronAir will not be held liable for any extra charges incurred due to lack of access and space for airflow.
- Under all circumstances, condenser air must not recirculate back onto condenser coil. Keep all clearance free of any obstructions.
- Maximum External Static of Outdoor Fans is 20 Pa.
- STACKING OF UNITS: Ensure that minimum airflow and clearances are met.
- MTG C-C DIST = Mounting Centre to Centre Distance.
- Use M12 bolt for feet mounting.
- Diagrams are left handing.

## 05.02. PKY960T

DIMENSION (H x W x L) = 2155 x 2250 x 2920  
 SUPPLY DUCT (H x W) = 1200 x 600  
 RETURN DUCT (H x W) = 1200 x 600

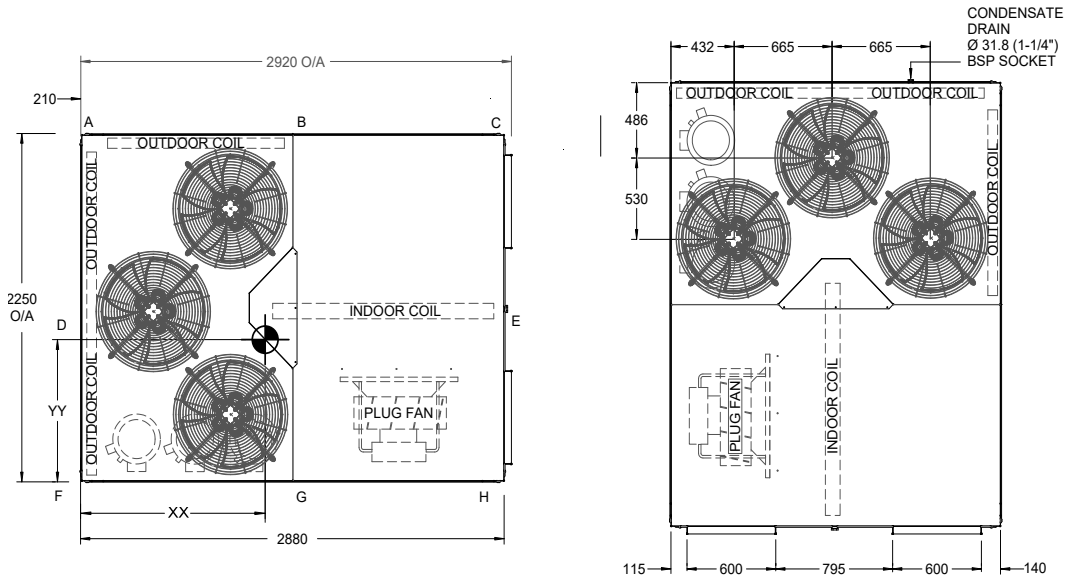
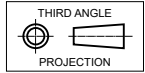

**TOP VIEW**

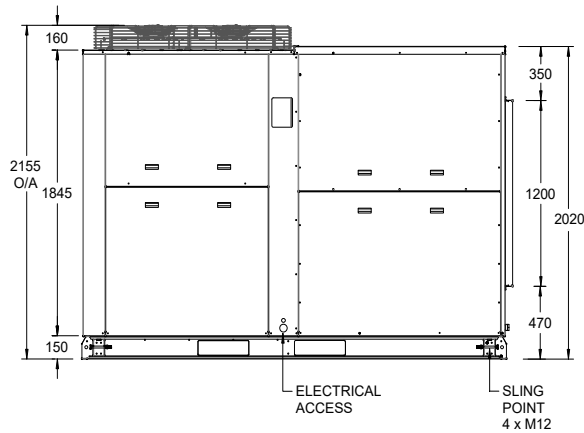

**SIDE VIEW**

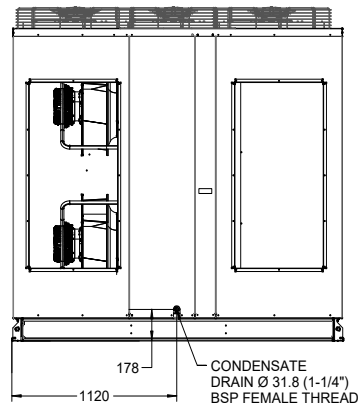

**FRONT VIEW**

Unit Air Handling Configuration (LH / RH)	Unit Weight (kg)	Corner Weights (kg)								Centre of Gravity Position	
		A	B	C	D	E	F	G	H	XX	YY
Left Handing	1350	143	282	51	85	212	236	297	44	1272	933
Right Handing	1350	142	255	24	86	215	236	322	70	1250	1052

**NOTES:**

- Do not scale drawing. All dimensions are in mm unless specified. Refer to corresponding unit dimensional drawing for mounting hole details.
- LH/RH refers to Left Hand or Right Hand location of supply air.
- Service Access Areas and Spaces for Airflow Clearances given above are suggested minimum based on the condition that the spaces around the units are free from any obstructions and a walkway passage of 1000 mm between the units or between the unit and the outside perimeter is available.
- Minimum service access areas and spaces for airflow clearances are responsibilities of the installer, ActronAir will not be held liable for any extra charges incurred due to lack of access and space for airflow.
- Under all circumstances, condenser air must not recirculate back onto condenser coil. Keep all clearance free of any obstructions.
- Maximum External Static of Outdoor Fans is 20 Pa.
- STACKING OF UNITS: Ensure that minimum airflow and clearances are met.
- MTG C-C DIST = Mounting Centre to Centre Distance.
- Use M12 bolt for feet mounting.
- Diagrams are left handing.

## 05.03. Service Access Areas and Airflow Clearances

PKY820T / PKY960T

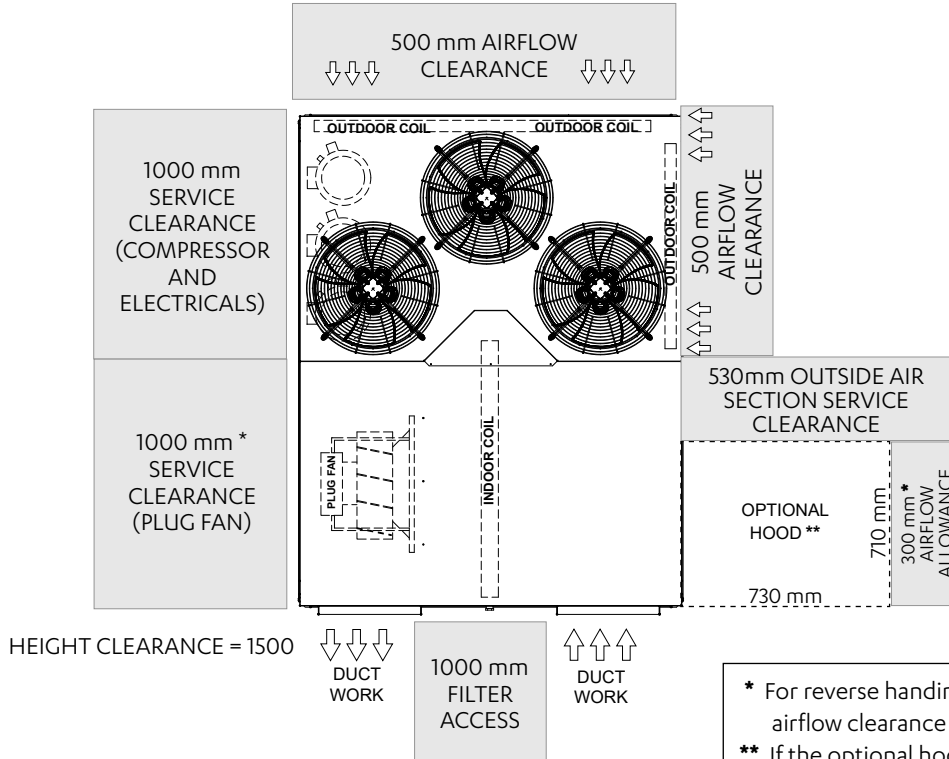

\* For reverse handing, service clearance for plug fan and airflow clearance for hood will be reversed.

\*\* If the optional hood is not installed, 500mm clearance is required for service access.

### Base Mounting Details

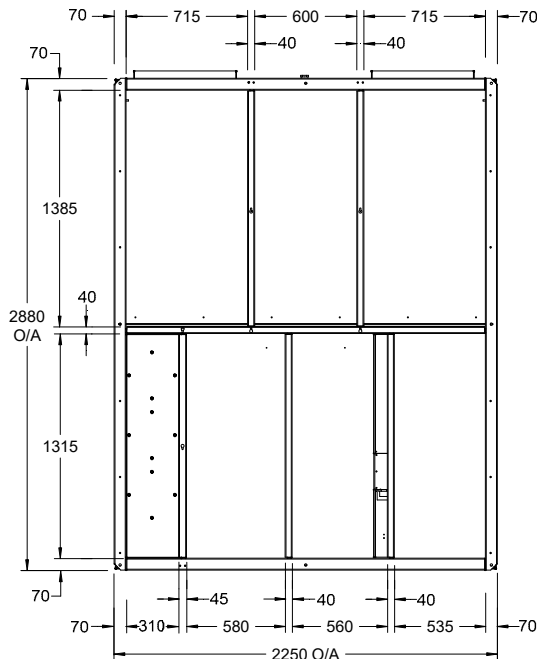

#### NOTES:

1. Do not scale drawing. All dimensions are in mm unless specified. Refer to corresponding unit dimensional drawing for mounting hole details.
2. LH/RH refers to Left Hand or Right Hand location of supply air.
3. Service Access Areas and Spaces for Airflow Clearances given above are suggested minimum based on the condition that the spaces around the units are free from any obstructions and a walkway passage of 1000 mm between the units or between the unit and the outside perimeter is available.
4. Minimum service access areas and spaces for airflow clearances are responsibilities of the installer, ActronAir will not be held liable for any extra charges incurred due to lack of access and space for airflow.
5. Under all circumstances, condenser air must not recirculate back onto condenser coil. Keep all clearance free of any obstructions.
6. Maximum External Static of Outdoor Fans is 20 Pa.
7. STACKING OF UNITS: Ensure that minimum airflow and clearances are met.
8. MTG C-C DIST = Mounting Centre to Centre Distance.
9. Use M12 bolt for feet mounting.
10. Diagrams are left handing.



## 06. UNIT LIFTING PROCEDURES

### 06.01. Crane Lifting Method

#### NOTE

Crane lifting is recommended over fork lift method.

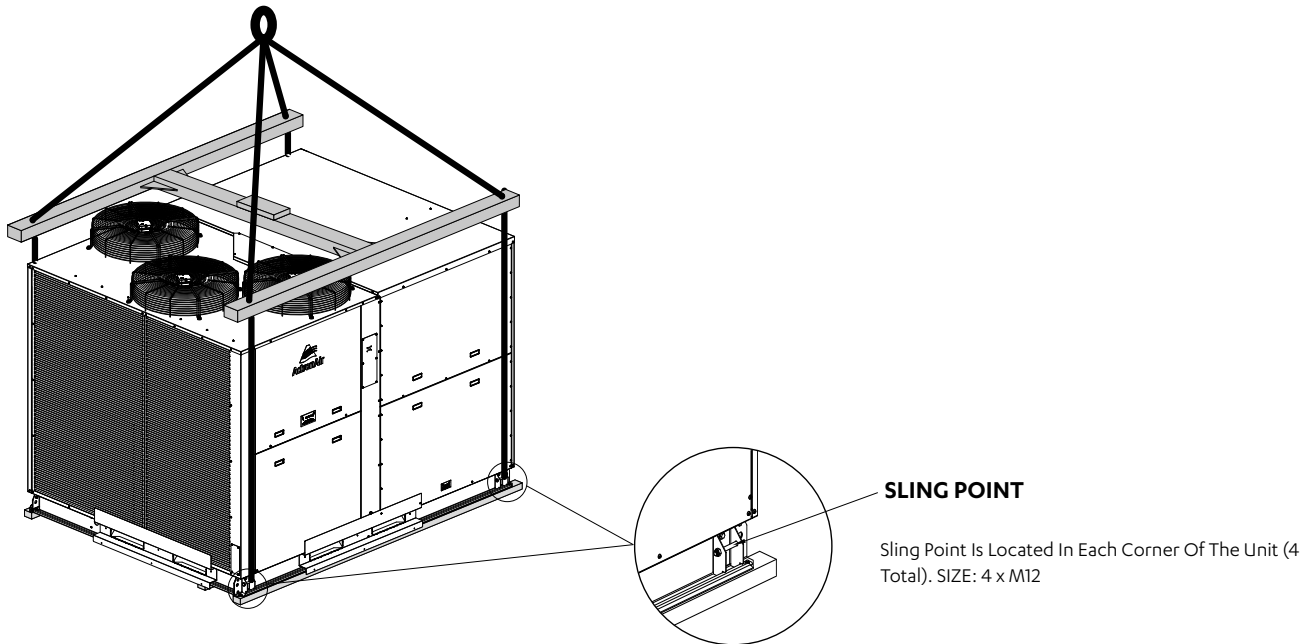

#### ⚠ CAUTION

WH&S regulations must be observed and will take precedent during lifting process.

#### Equipment required for crane lifting:

- 4 x Shackles
- 2 x Nylon Slings
- Spreader bar

#### NOTE

Refer to catalogue for unit weight before selecting shackles.

#### PROCEDURE:

1. Use 4 x Bow or Dee shackles to connect the lifting holes.
2. Slip nylon slings through all shackles.
3. Ensure slings are protected by rubber pads or similar if slings are draped across unit edges, corners, supply or return air spigots. This will prevent the unit from being damaged during lifting.
4. SPREADER BAR must be used when lifting the unit.
5. Remove all screws and washers that secure the unit to the timber pallet.
6. Remove pallet from the unit. (See pallet removal instructions below).

## 06.02. Fork Lifting Method

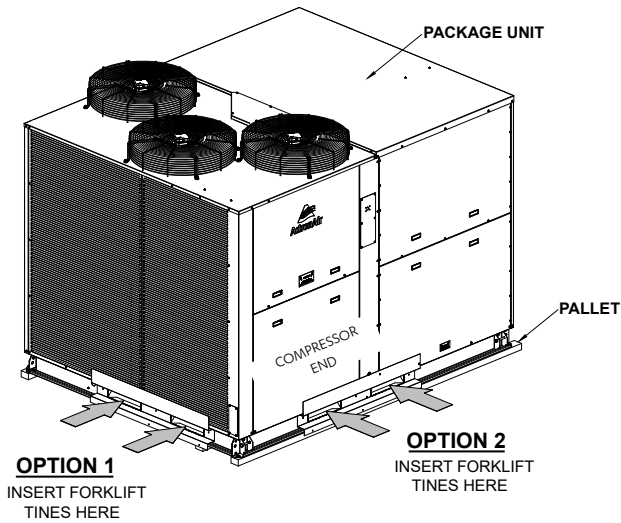

### NOTE

- Two pallet lifting location shown, fork lifting Option 1 and Option 2.
- Ensure to remove screws and washers only when it is required to disassemble unit from the pallet.

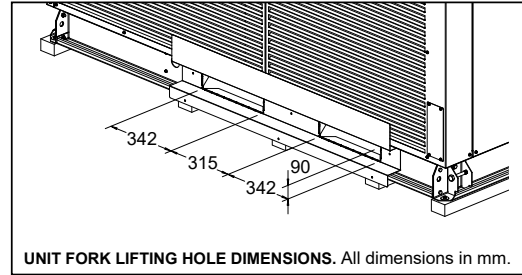

### Procedure:

1. To move the unit around with a forklift, insert the fork tines through the unit feet assembly as shown.
2. Only fork the unit through compressor end (See illustration for location of compressor end).

### NOTE

Length of fork lift tines must pass the unit middle section, in order to safely carry the unit.

### Pallet Removal Instructions

1. Remove Plate-Unit Protector from pallet and unit assembly.

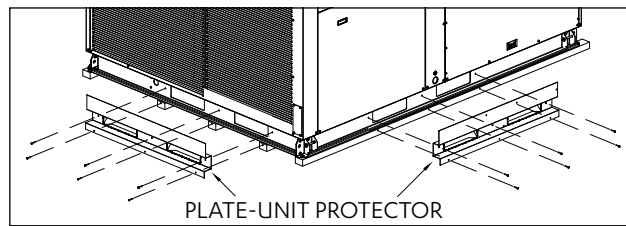

2. Remove Pallet from the unit as shown: (Lift unit to remove pallet by lifting method A or B)

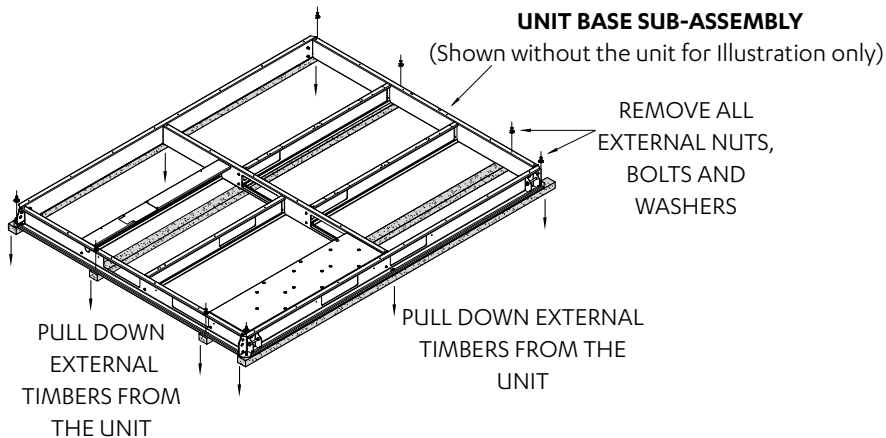

## 07. CONDENSATE AND SAFETY TRAY DRAINAGE INSTRUCTIONS

### 07.01. Suggested Minimum Slope To Ensure Correct Drainage

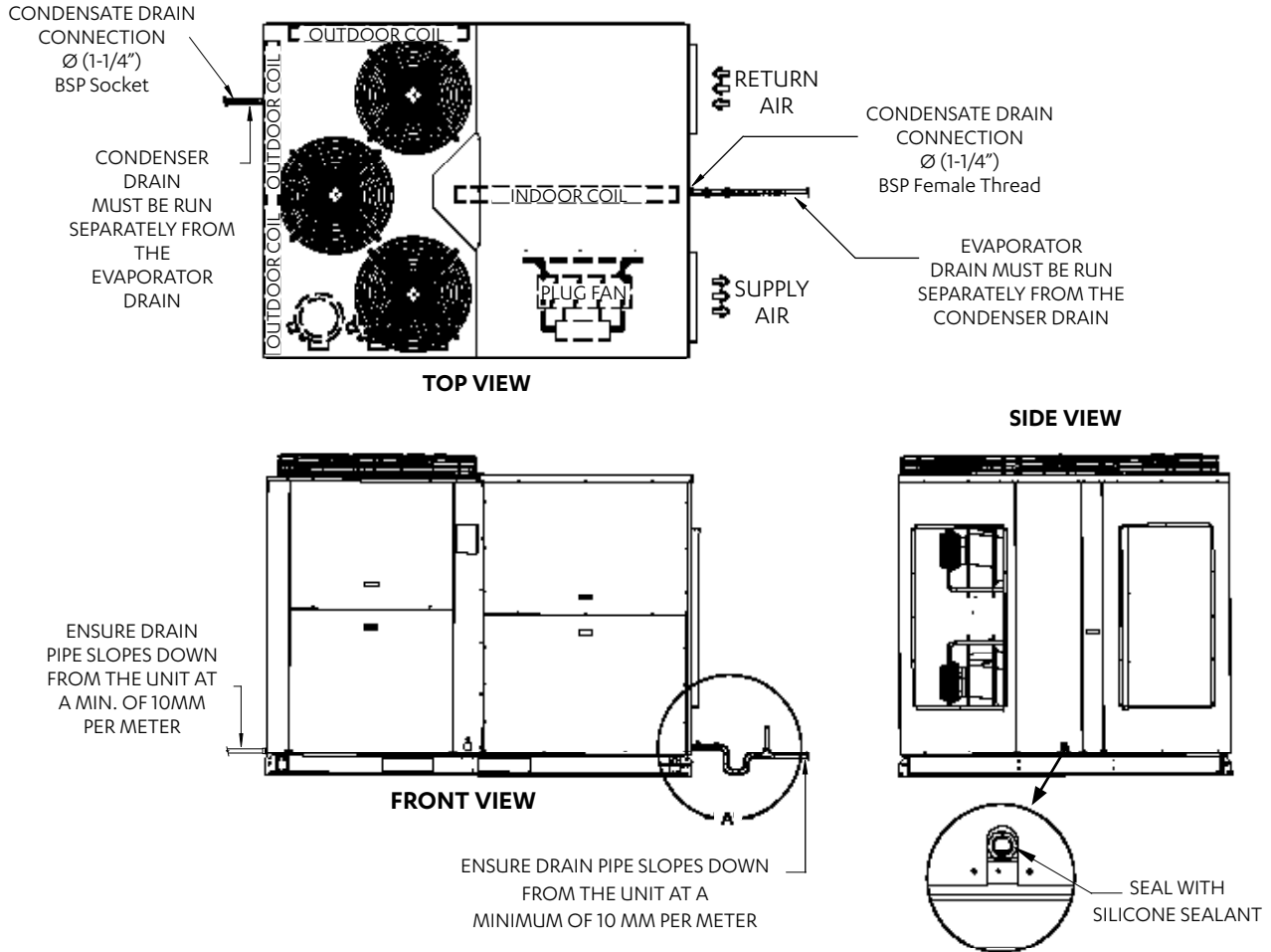

### 07.02. Suggested Drain Trap Details

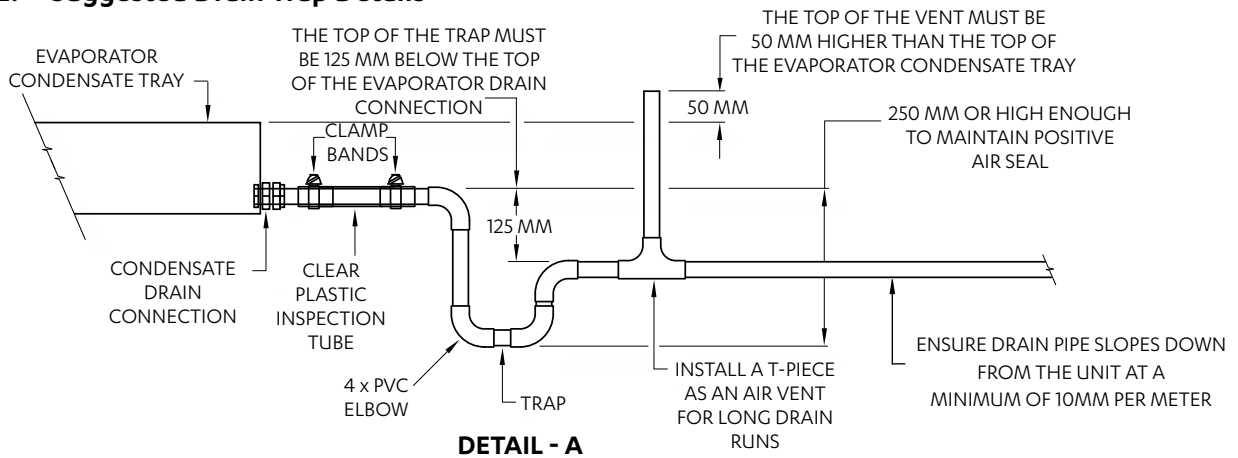

#### NOTES

- Parts for the Condensate Trap are not supplied with the unit.
- Refer to Unit Dimensions page of the Technical Selection Catalogue for specifications of drain connectors.

## 08. BANKING OF UNITS

### 08.01. End-To-End Configuration

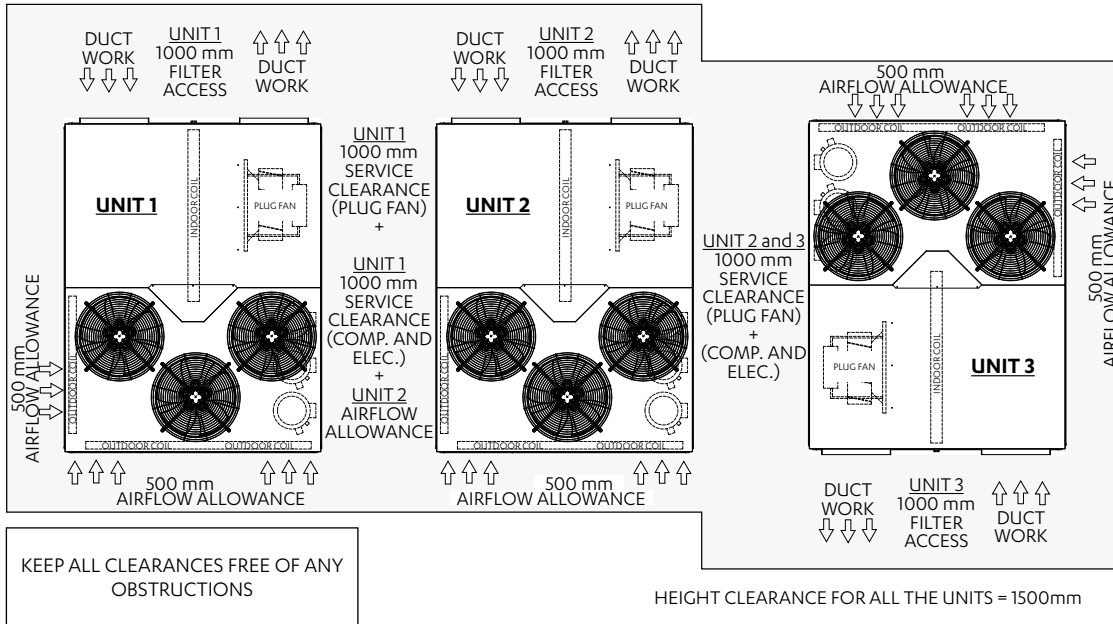

### 08.02. Cluster Configuration

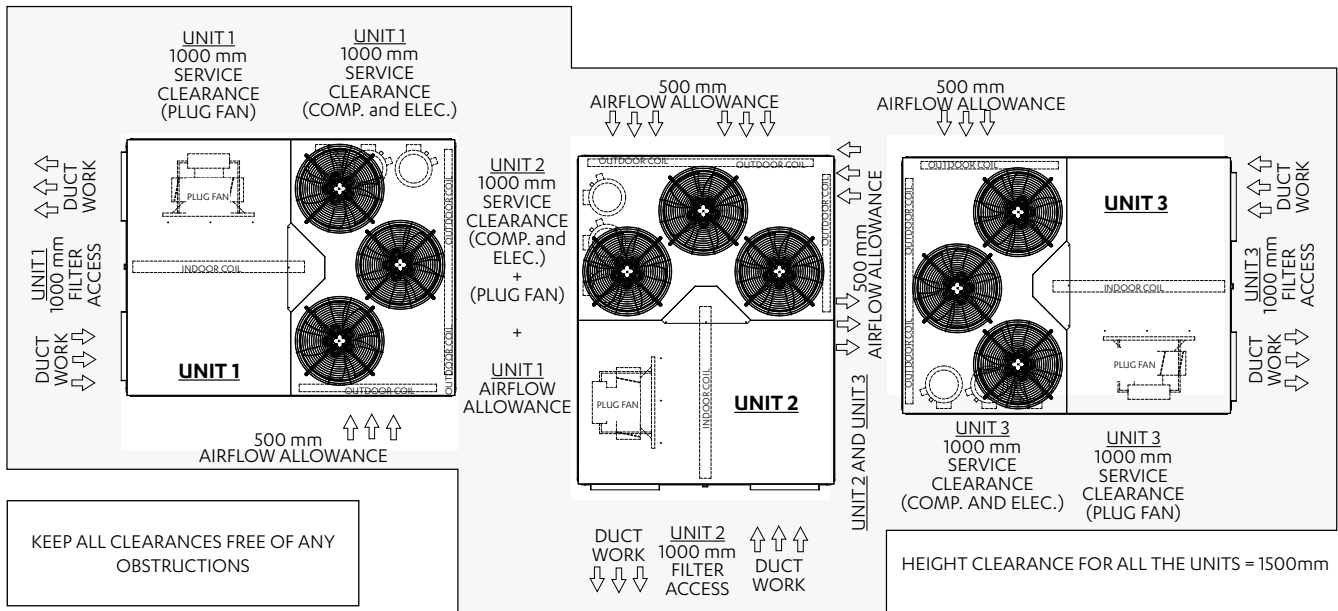

#### NOTES

- The suggested Clearance and Airflow Allowances (given above) are the minimum and based on the condition that the spaces around the units are free from any obstructions and walkway passage of 1000 mm between the units or between the unit and the outside perimeter is available.
- Minimum service access areas and spaces for airflow are responsibilities of the installer, ActronAir will not be held responsible for any extra charges incurred due to lack of access and space for airflow.
- Do not scale drawing.

**08.03. Side-By-Side Configuration**

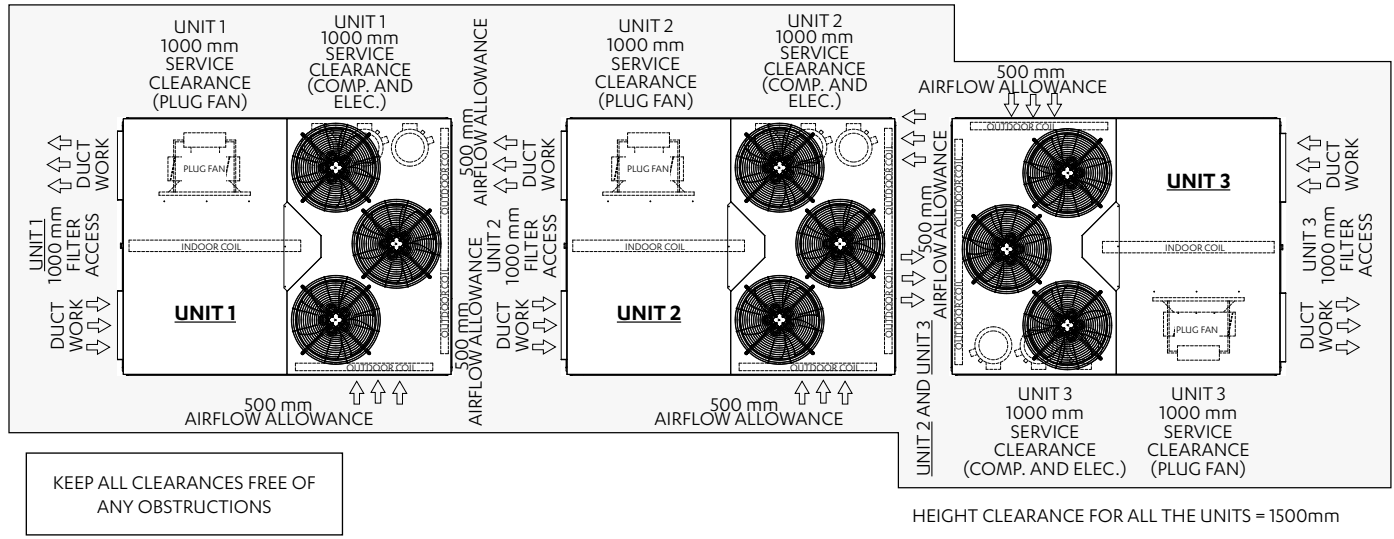

**08.04. End-To-End Configuration (With Optional Hood) \*\*\***

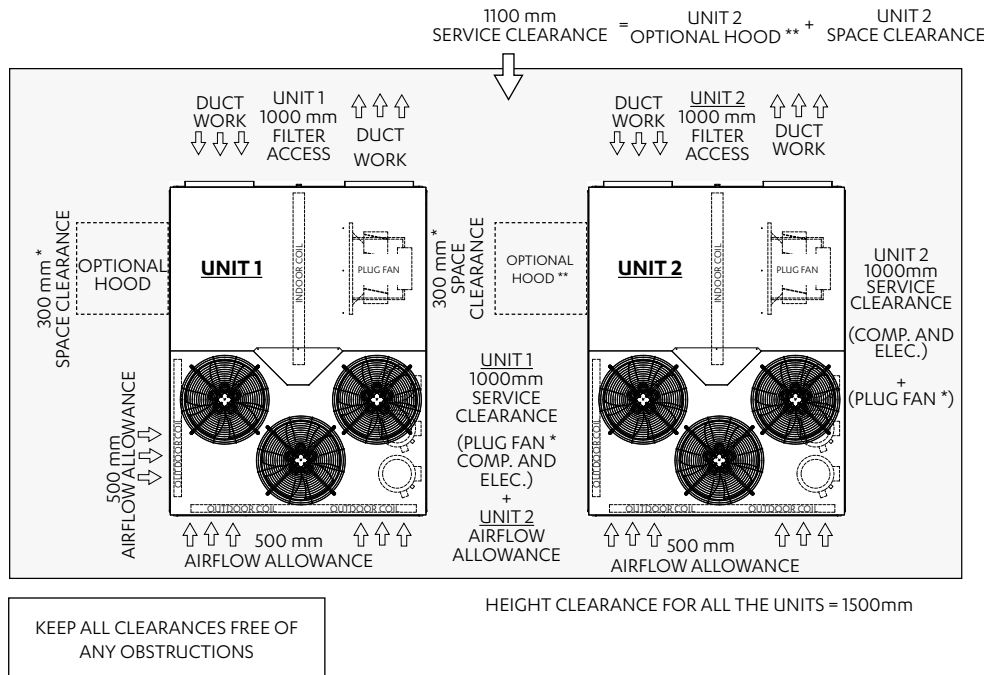

**NOTES**

- The suggested Clearance and Airflow Allowances (given above) are the minimum and based on the condition that the spaces around the units are free from any obstructions and walkway passage of 1000 mm between the units or between the unit and the outside perimeter is available.
- Minimum service access areas and spaces for airflow are responsibilities of the installer, ActronAir will not be held responsible for any extra charges incurred due to lack of access and space for airflow.
- Do not scale drawing.

08.05. Side-By-Side Configuration

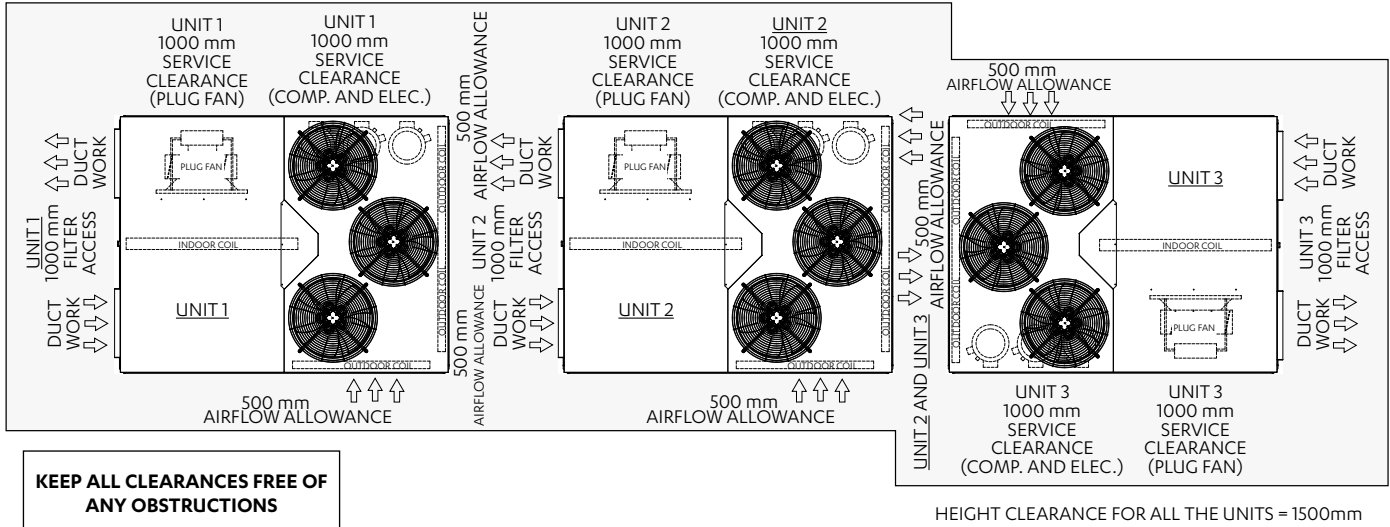

08.06. End-To-End Configuration (With Optional Hood) \*\*\*

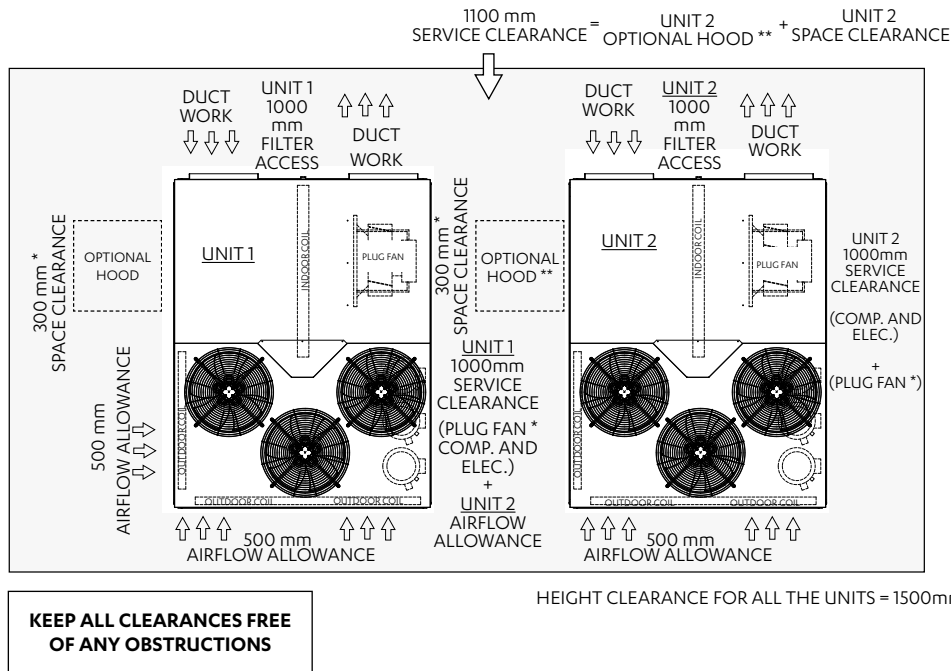

\* For Reverse Handling, Plug Fan service clearance and Optional Hood space clearance will be reversed.  
 \*\* Remove Optional Hood when service is required for the Plug Fan of the opposite unit.  
 \*\*\* Configuration shown above is a sample only of the many possibilities of unit banking configurations with Optional Hood application. Provide a 300mm Space Clearance for the Optional Hood as shown.

NOTES

- The suggested Clearance and Airflow Allowances (given above) are the minimum and based on the condition that the spaces around the units are free from any obstructions and walkway passage of 1000 mm between the units or between the unit and the outside perimeter is available.
- Minimum service access areas and spaces for airflow are responsibilities of the installer, ActronAir will not be held responsible for any extra charges incurred due to lack of access and space for airflow.
- Do not scale drawing.

## 09. PARTS LAYOUT

### 09.01. PKY820T / PKY960T

Standard Model

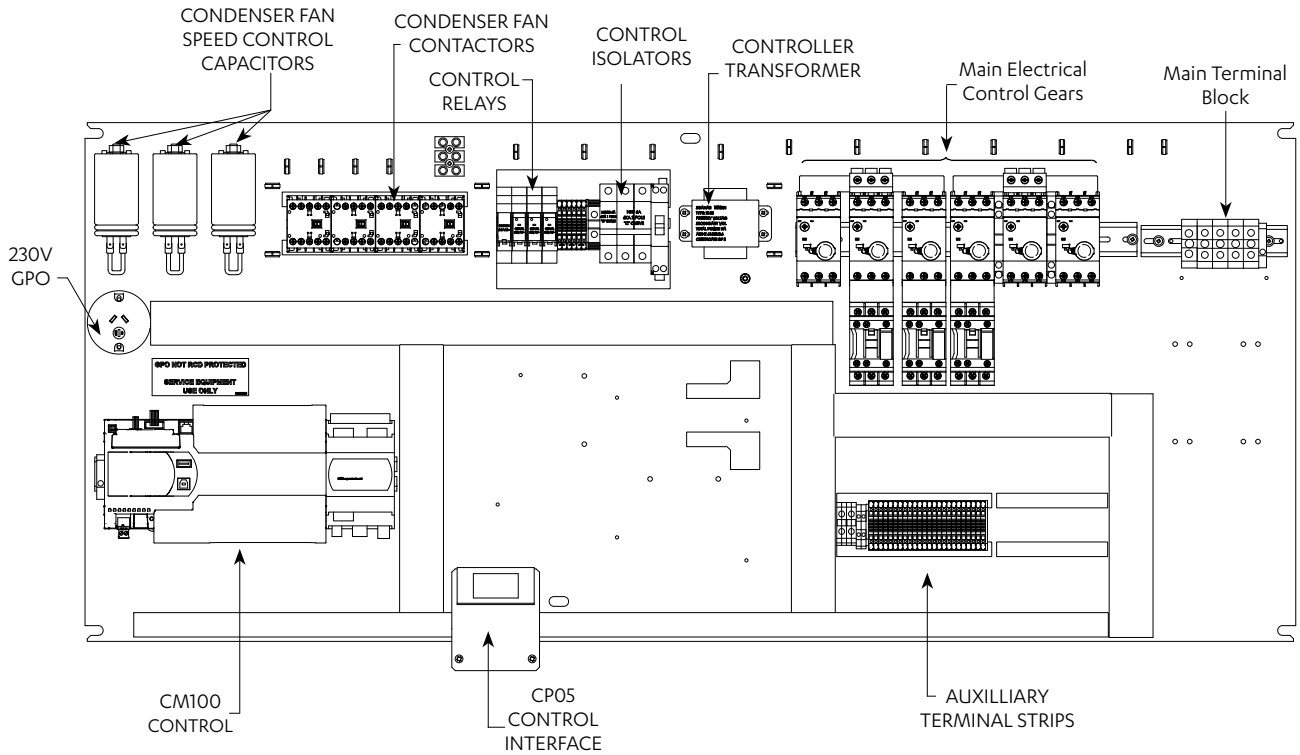

### 09.02. PKY820T / PKY960T

Standard Model With Optional 3-Phase Protection Relay

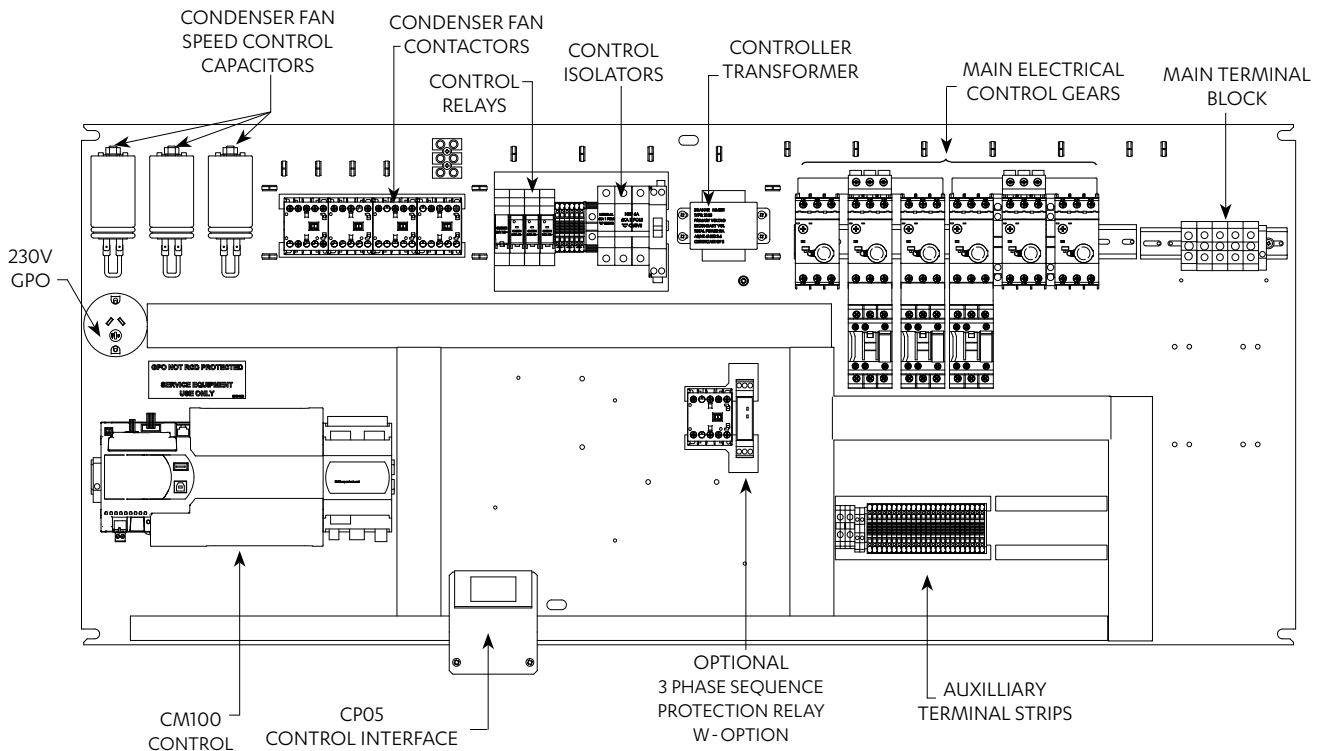

## 09.03. PKY820T / PKY960T

Standard Model With Optional 3-Phase Soft Starters

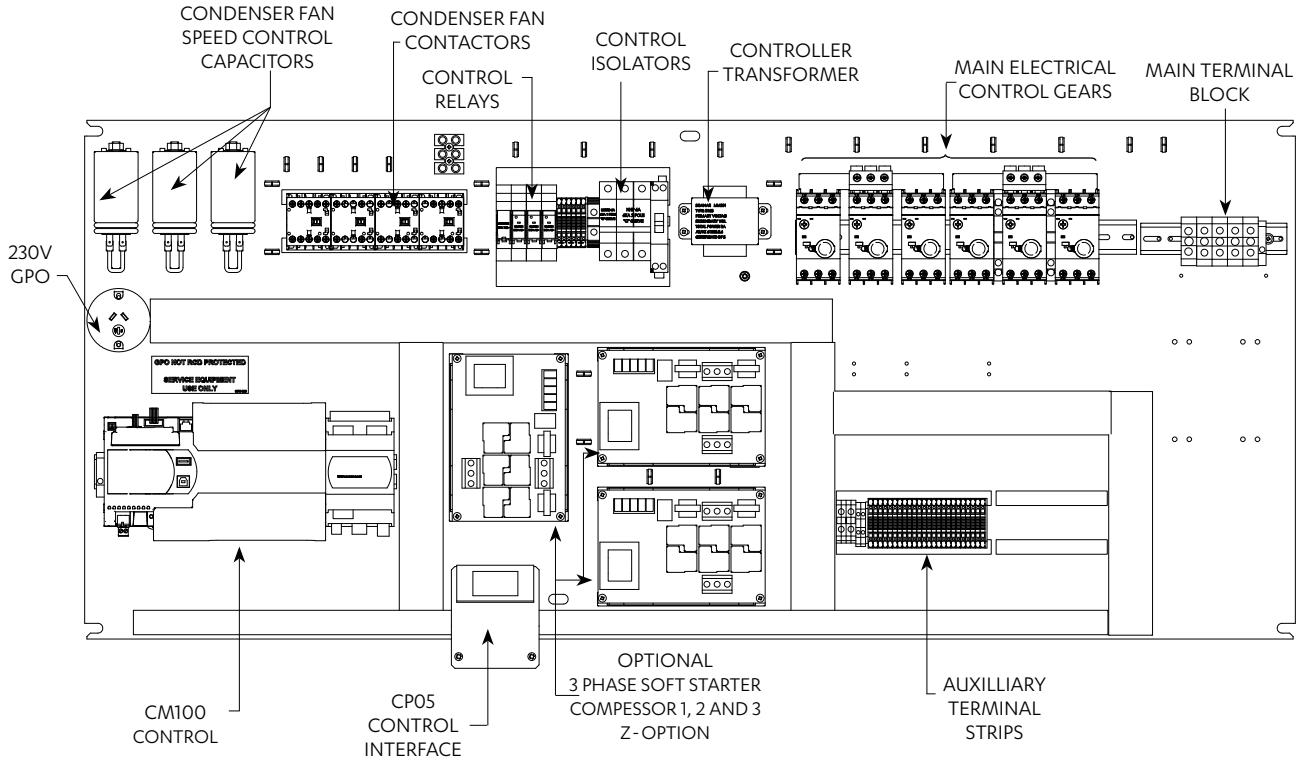

## 09.04. PKY820T / PKY960T

W/ Optional EC Condenser Fans

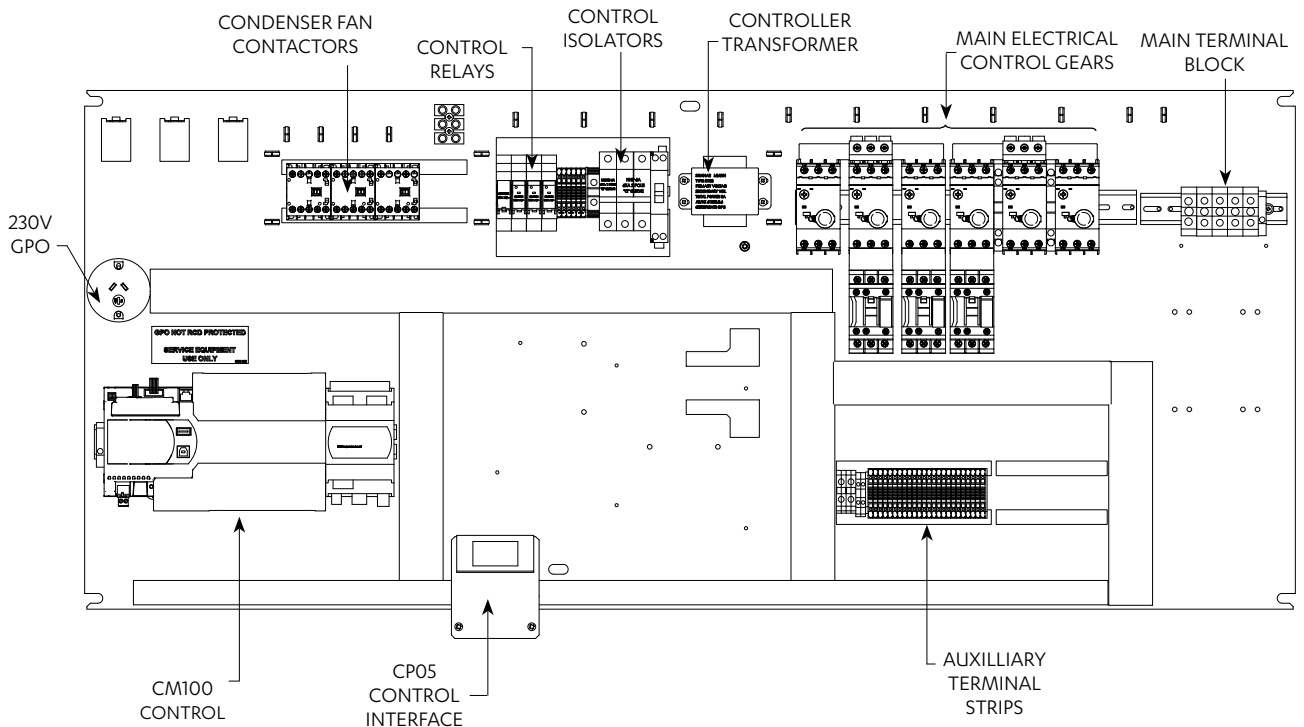



## 09.05. PKY820T / PKY960T

W/ Optional EC Condenser Fans And Optional 3-Phase Protection Relay

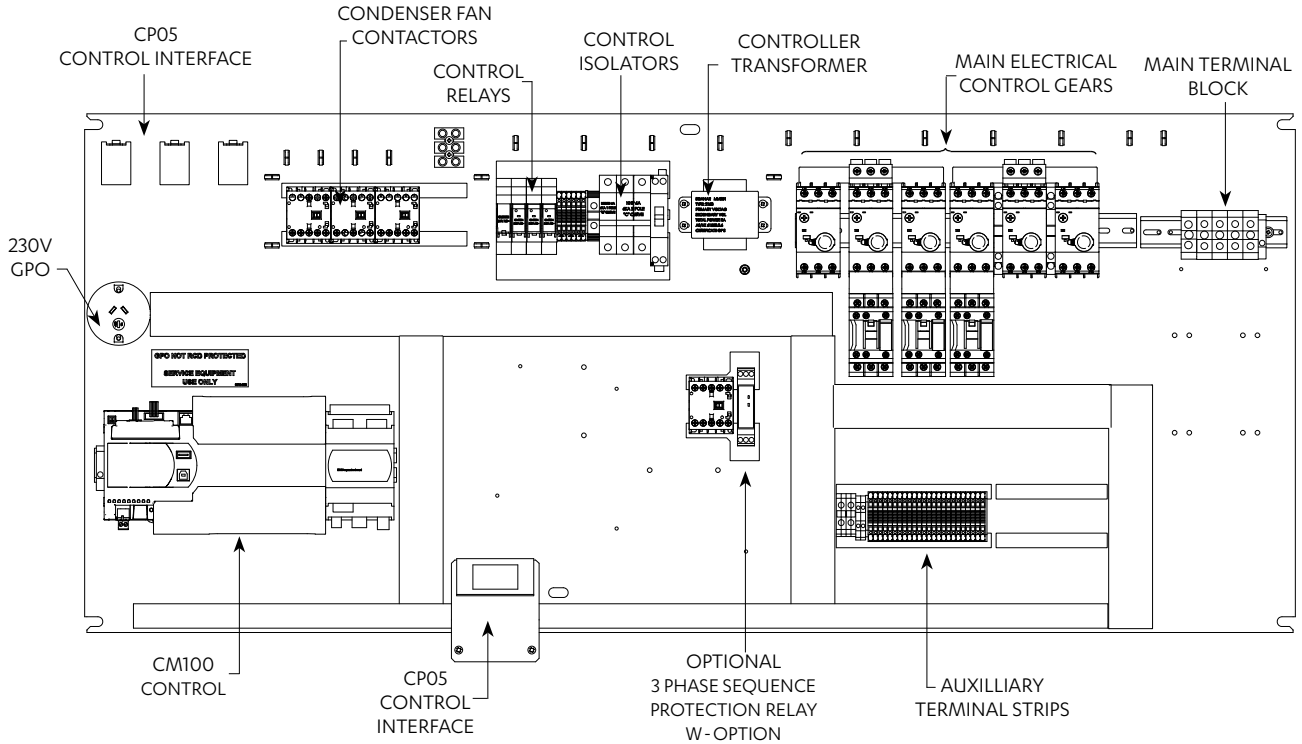

## 09.06. PKY820T / PKY960T

W/ Optional EC condenser fans and optional 3-phase soft starters

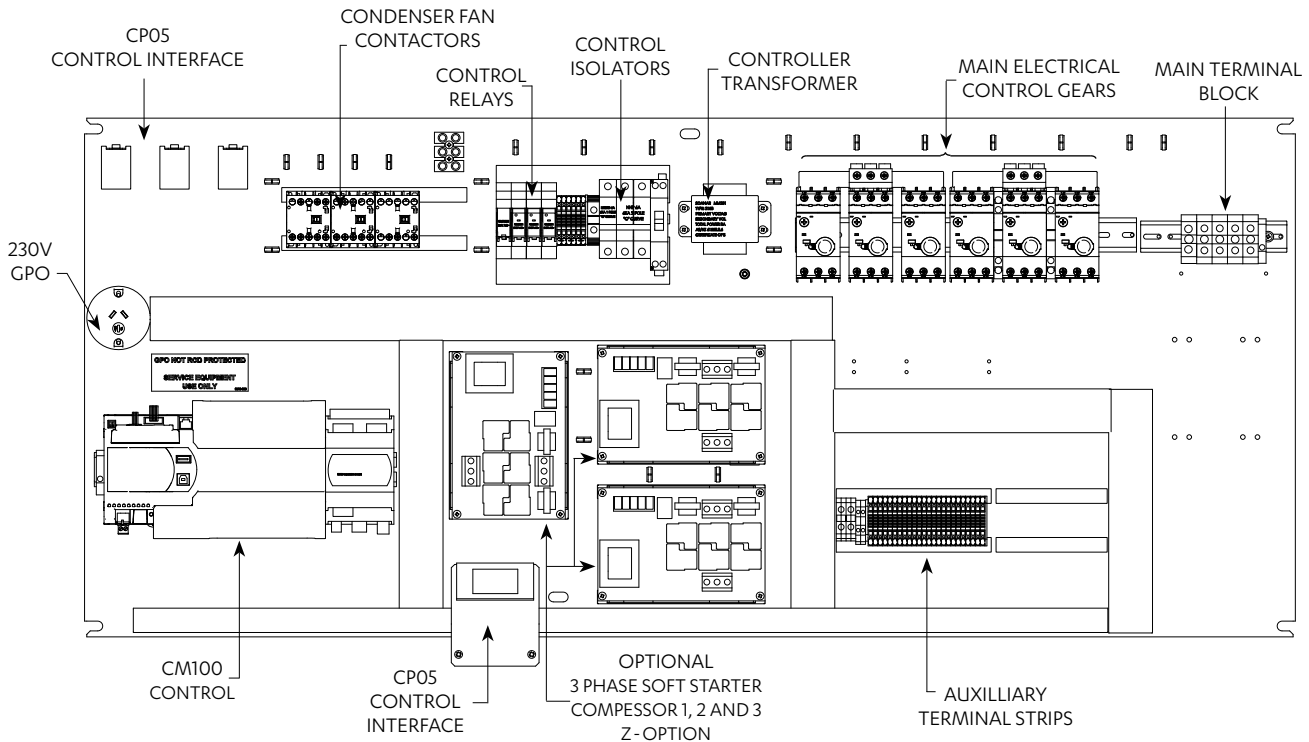

## 10. UNIT PREPARATION

### 10.01. Supply and Return Angle Plate Installation

Supply Angle Assembly

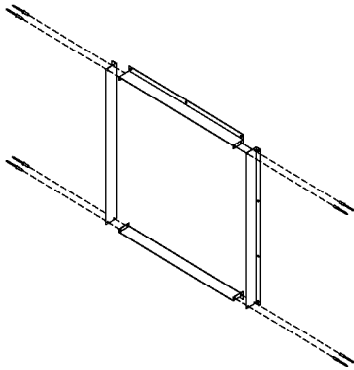

1. Assemble supply angle short plate and supply angle long plate using the provided rivet as shown above.

Materials:

- Supply angle short plate x 2 pieces.
- Supply angle long plate x 2 pieces.
- Rivet x 8 pieces.

2. Attach the supply angle assembly onto supply air opening using provided screws as shown below.

Material

- Stainless steel screw 12G x 5/8 x 16 pieces.

Return Angle Assembly

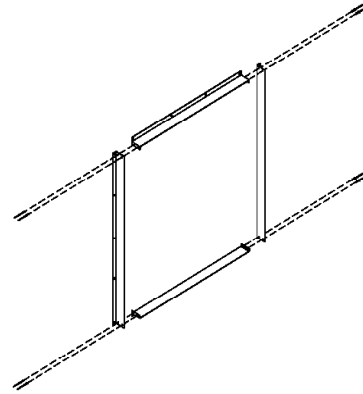

1. Assemble return angle short plate and return angle long plate using the provided rivet as shown above.

Materials:

- Return angle short plate x 2 pieces.
- Return angle long plate x 2 pieces.
- Rivet x 8 pieces.

2. Attach the return angle assembly onto supply air opening using provided screws as shown below.

Material

- Stainless steel screw 12G x 5/8 x 16 pieces.

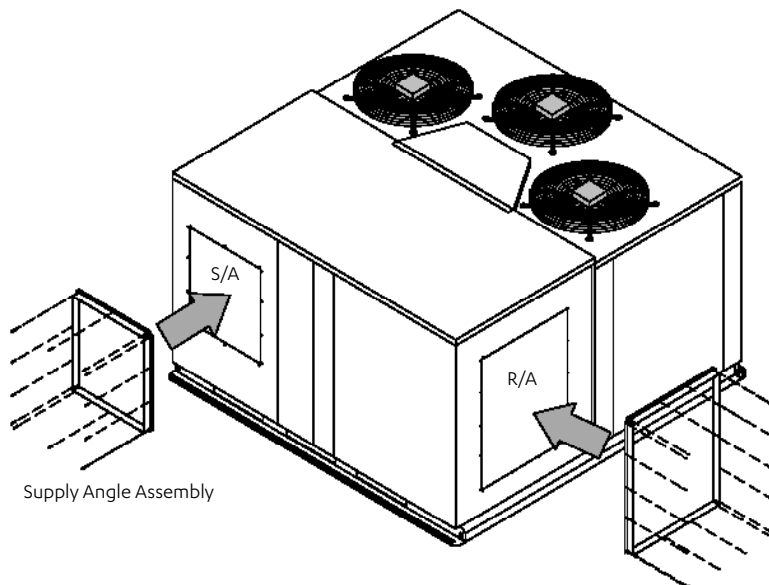

Supply Angle Assembly

Return Angle Assembly

#### NOTE

Supply Air / Return Air angle with optional Left Hand or Right Hand side configuration are not factory fitted. These are to be field assembled and fitted by the installer.

#### NOTES

- All screws, rivets and supply return plates are supplied with the unit.
- All items are packed and located inside return air plenum (either beside indoor plug fan or on the filter rail)
- This assembly instruction is also applicable to the following unit options:
  - (a) supply air side, (b) supply air front, (c) return air side and (d) return air front.
- Tools required (not supplied): rivet gun and Phillips screw driver.

## 10.02. Supply and Return Angle Plate Assembly / Installation

### Supply Air Angle and Return Air Angle Sub Assembly

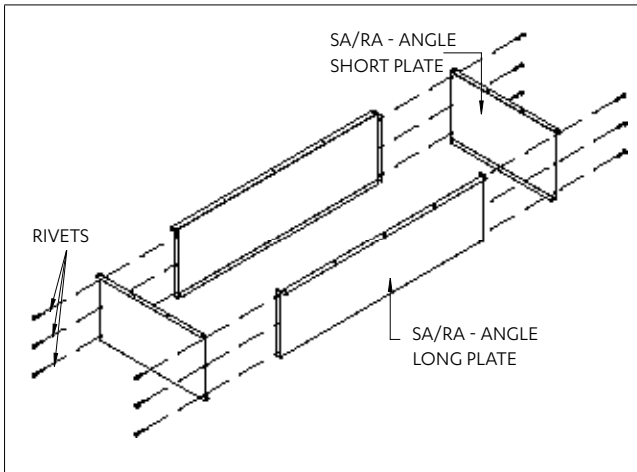

**1. Assemble supply air and return air angle plates using the provided rivet as shown in illustration on left.**

Materials:

- 2 Pieces - Supply Angle Short Plate
- 2 Pieces - Supply Angle Long Plate
- 2 Pieces - Return Angle Short Plate
- 2 Pieces - Return Angle Long Plate
- 24 Pieces - Rivets
- 12 Pieces - M8 Bolts
- 1 Roll - PVC Closed Cell Tape

**2. Attach the supply angle assembly onto supply air opening by following detail - A procedures below.**

**3. Follow Step 2 to attach the return angle assembly.**

**NOTE:** Quantity of materials are half of the above for units with 1-Off Supply Air or Return Air assembly.

### Unit Assembly

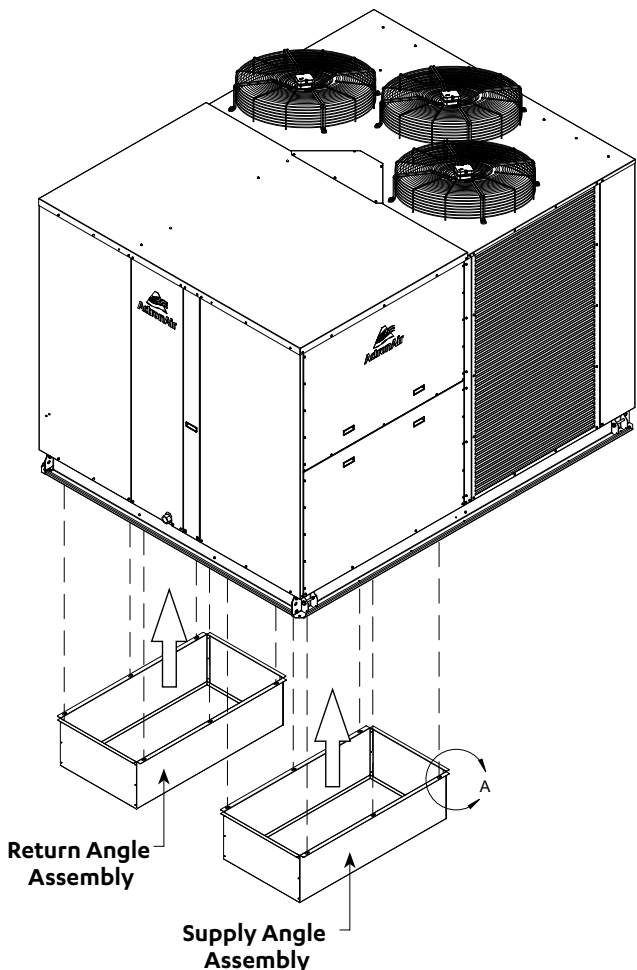

### NOTE

- Supply Air (SA) and Return Air (RA) assemblies have common parts and items.
- All bolts, rivets and supply and return plates are supplied with the unit.
- All items are packed and located inside return air plenum (either beside indoor plug fan or on the filter rail).
- Apply PVC closed cell tape (supplied) to adjoining contact edges before fastening bolts to ensure tight air seal.
- Tools required (not supplied): rivet gun and socket wrench.

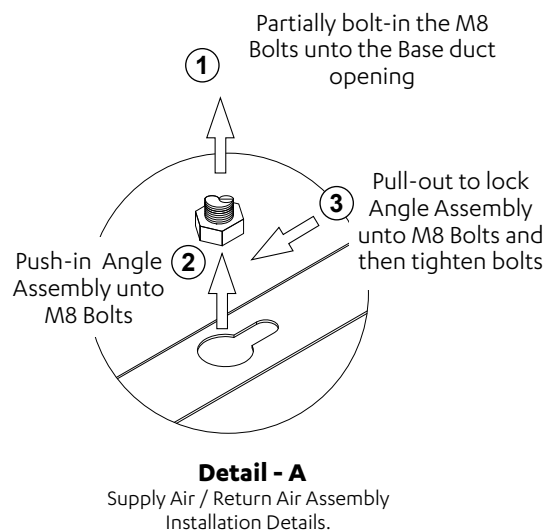

### NOTE

Bottom Supply Air / Return Air angle options are not factory fitted. These are to be field assembled and fitted by the installer.

10.03. Electrical Mains and Isolator Installation

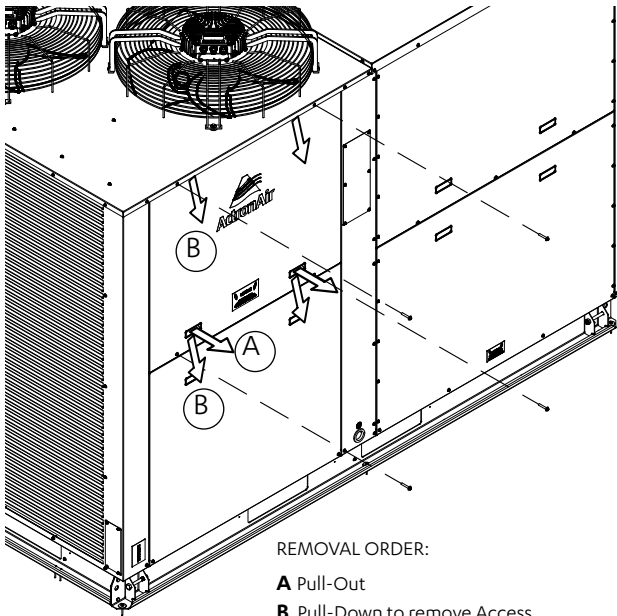

REMOVAL ORDER:  
**A** Pull-Out  
**B** Pull-Down to remove Access Panel-Electrical

1. Remove Access Panel - Electrical

- Remove mounting screws (4 pieces).

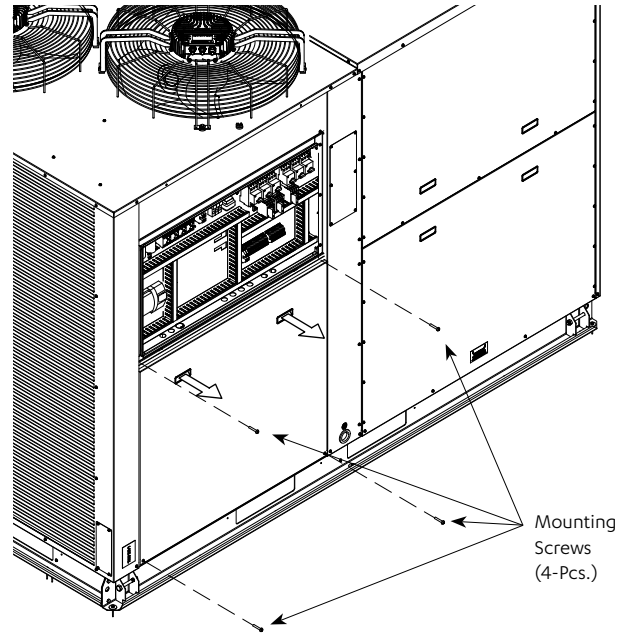

2. Remove Access Panel - Compressor

- Remove mounting screws (4 pieces).

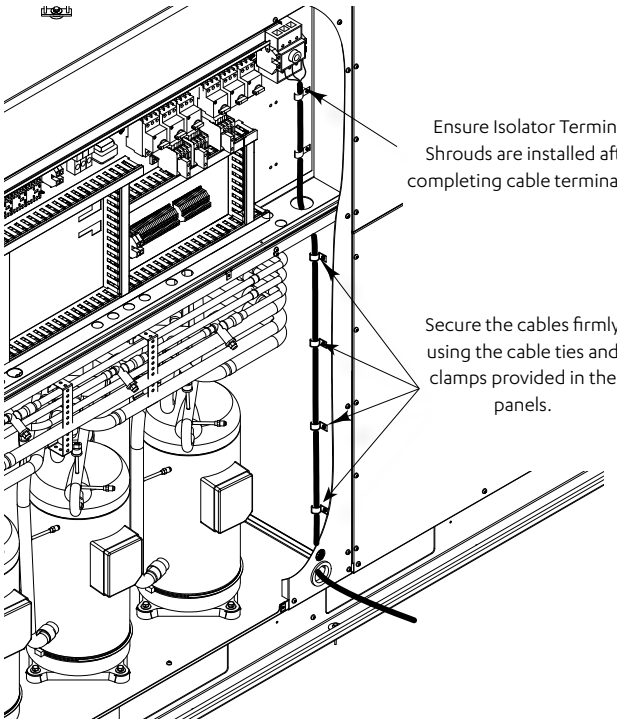

3. Connect electrical and control wirings

- Route electrical mains cable and wall control wires as shown.
- Refer to electrical section for electrical and control connections.

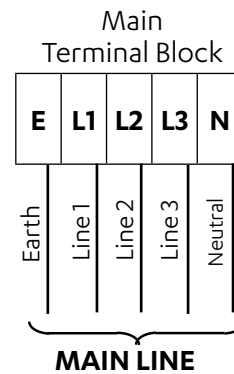

## 10.04. Compressor Shipping Blocks Removal

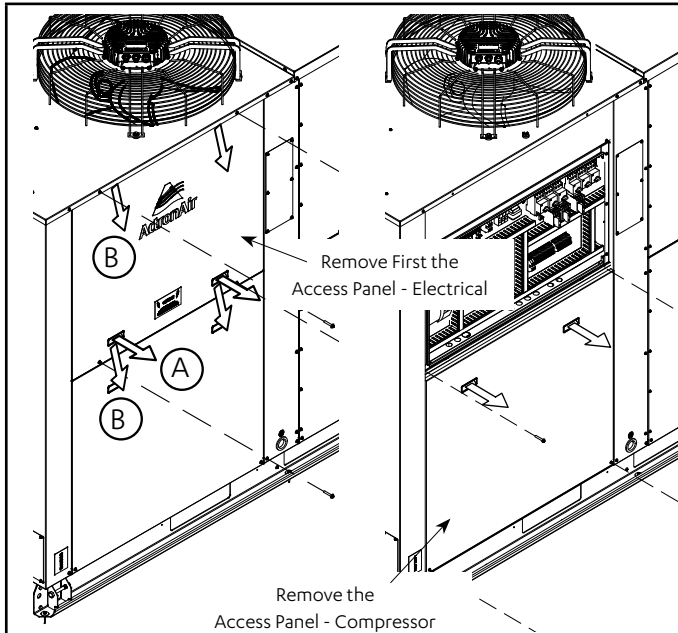

### 1. Remove Access Panel - Compressor

- Remove the Access Panel - Compressor by following the Access Panels removal procedure from previous page.

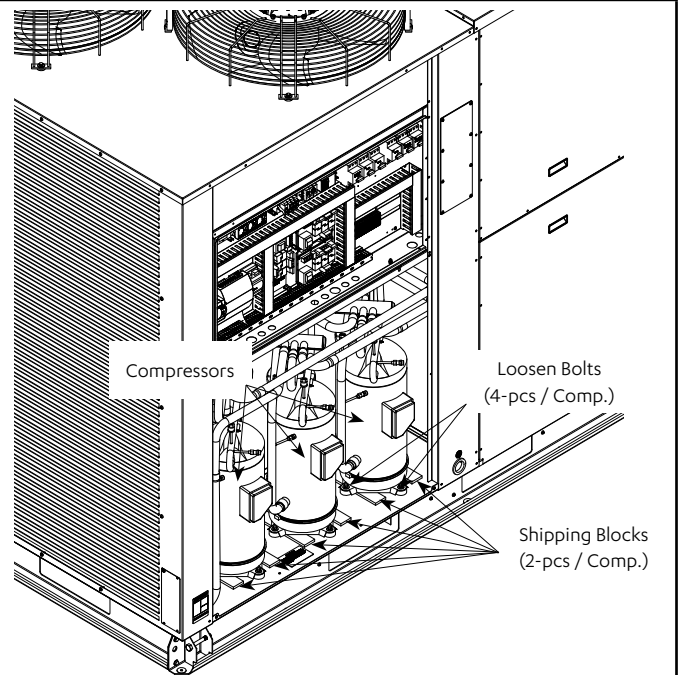

### 2. Loosen the Bolts - Compressor Mounting

- Loosen the bolts that hold the compressors down onto the unit (4 pieces each).

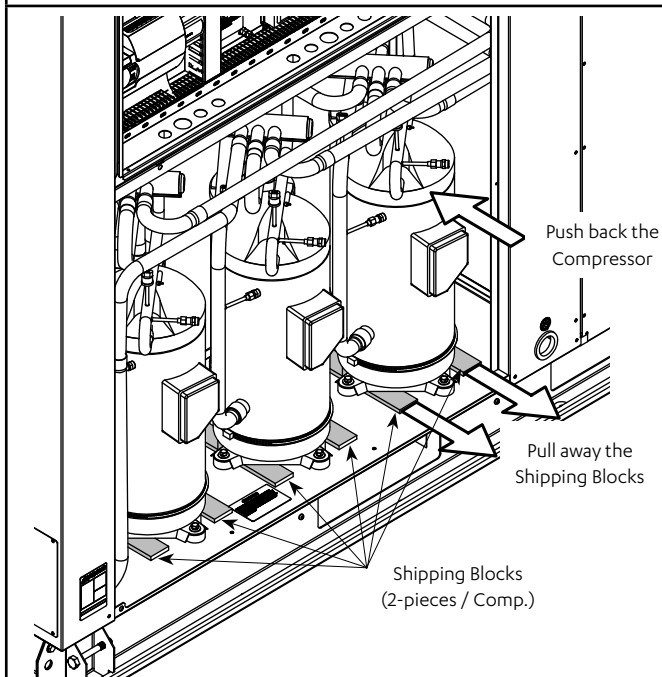

### 3. Remove the Shipping Blocks

- Push the Compressor back, taking care not to exert too much force that may cause damage to the pipes.
- Remove the Shipping Blocks by pulling them away.
- Repeat the same procedure for the other two compressors.

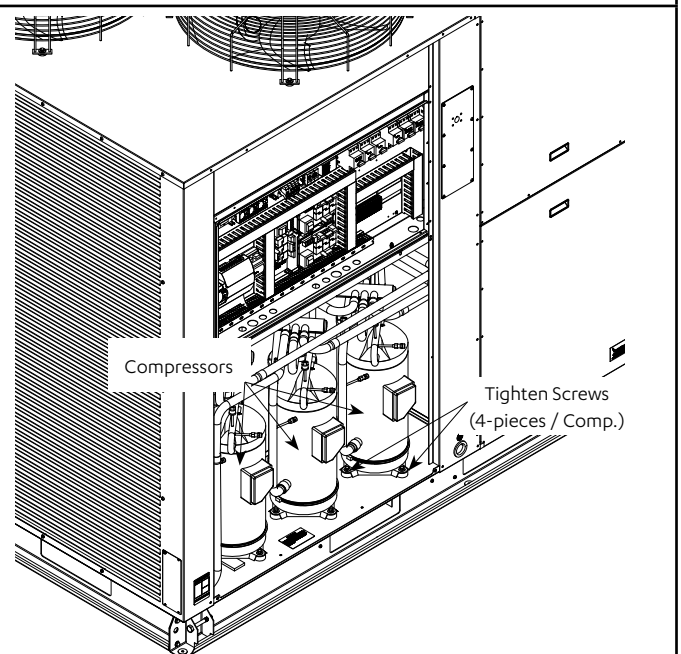

### 4. Tighten back the Bolts

- Firmly tighten the bolts to secure back the compressors onto the unit. Recommended torque is  $13 \pm 1$  Nm. It is critically important for the grommet not to be compressed.
- Check to make sure that there are no damage to the piping systems.

10.05. Air Filter Installation

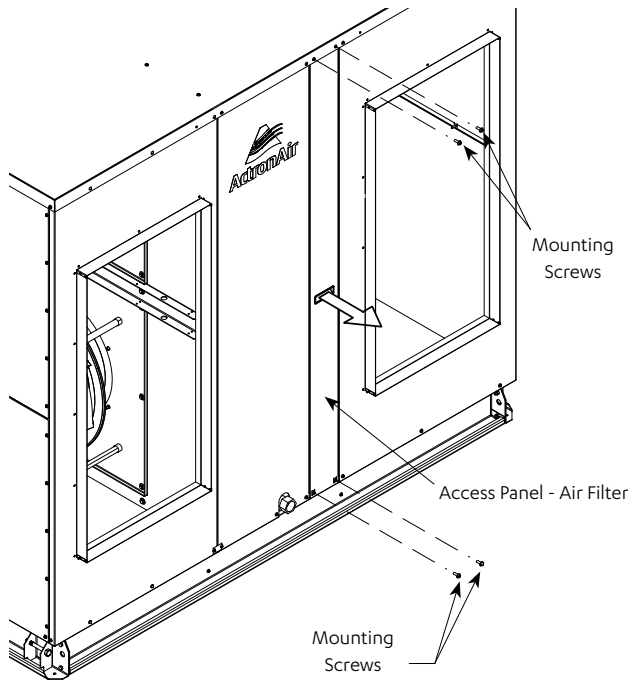

1. Remove Access Panel - Air Filter

- Remove mounting screws (4 pieces).
- Remove Access Panel - Air Filter as shown in the above illustration

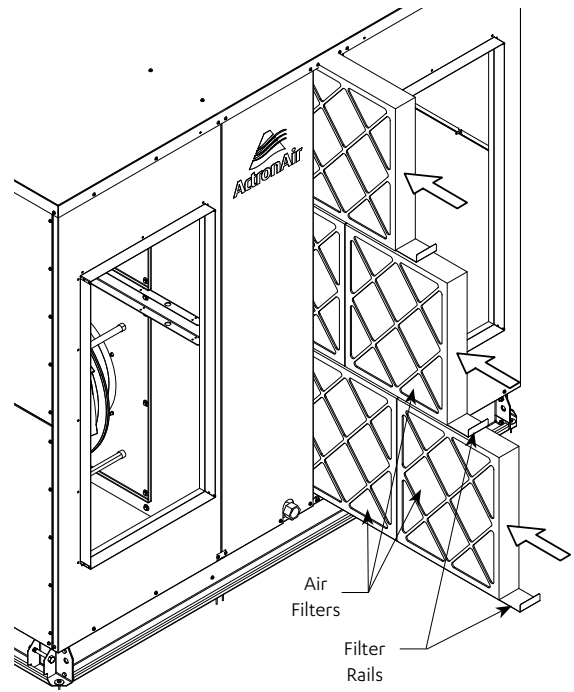

2. Install Air Filters

- Install Air Filters (9 pieces required) by sliding the filters one at a time in the provided Filter Rails. See notes and specifications below:

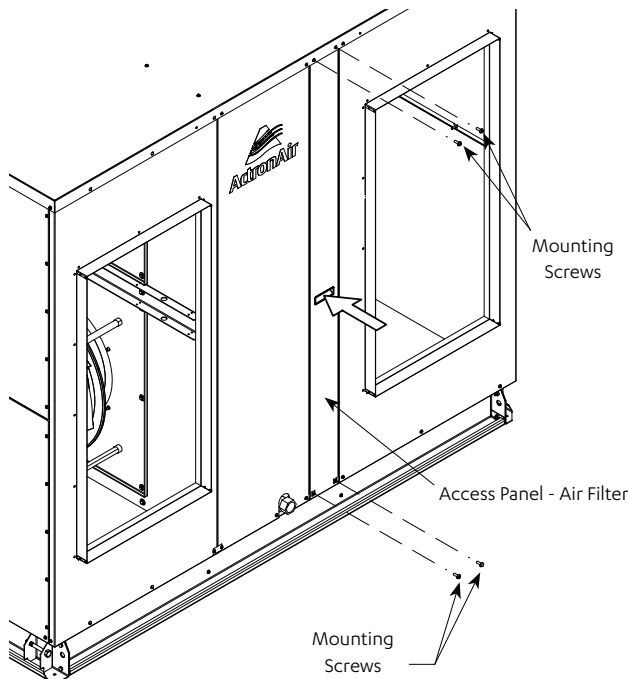

3. Replace Access Panel - Air Filter

- Replace Access Panel - Air Filter as shown above.
- Replace mounting screws, clean and tidy up the air conditioning unit.

NOTES

- Air Filters are not supplied with the unit.
- Adequate Air Filters must be supplied and fitted by the Installing Contractor.

AIR FILTER SPECIFICATIONS

Models	Qty	Air Filter Sizes (H x W x T - mm)
PKY820T-960T	9	594 x 492 x 96

## 11. ELECTRICAL

### NOTES

- All electrical work must be carried out by a qualified technician.
- Make sure all wiring is in accordance with local wiring rules.
- Wiring connections should be made in accordance with the provided wiring diagram.
- The unit wiring diagram is located in the Access Panel - Electrical.

### 11.01. Package Electrical Connection

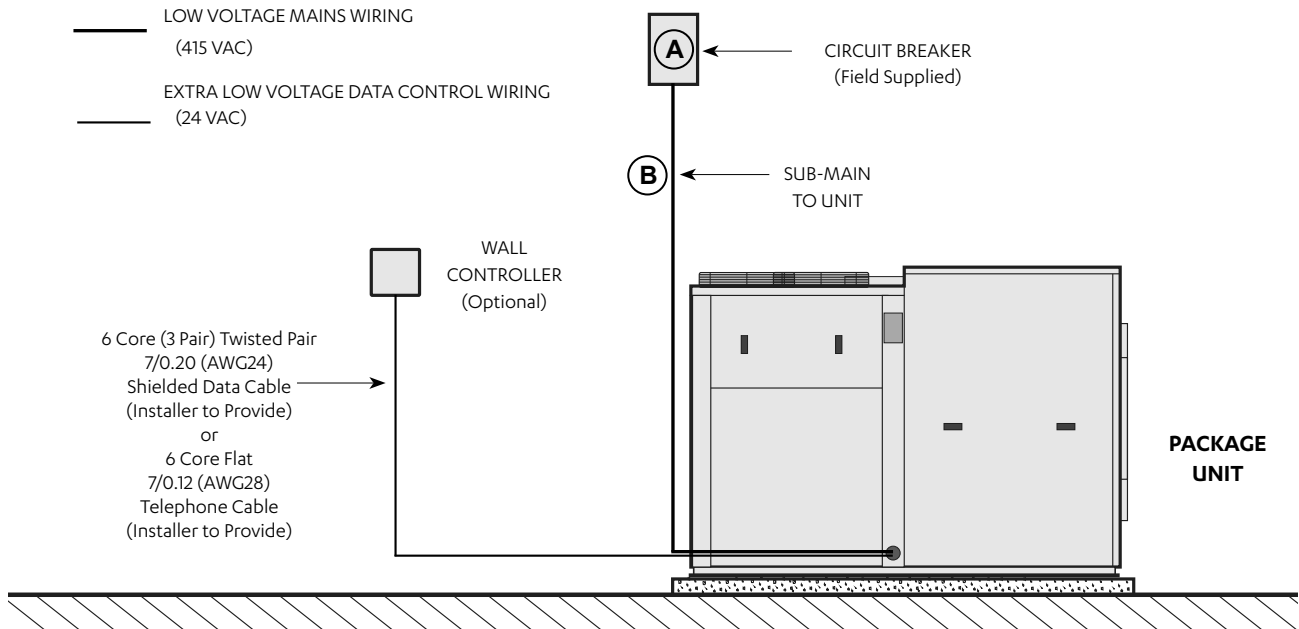

POWER CIRCUIT BREAKER SIZE AND CABLE SIZE		
Model	(A) Circuit Breaker Size	(B) Cable Size * (mm <sup>2</sup> )
	Amps	MAIN (4 Core + E)
PKY820T	80.0 ( D Curve Breaker)	25.0
PKY960T	100.0 ( D Curve Breaker)	35.0

\* Suggested Minimum Cable Size should be used as a guide only, refer to AS/NZS 3000 "Australian / New Zealand Wiring Rules" for more details.

WIRING DIAGRAM MATRIX	
Model	Wiring Diagram
PKY820T	0515-9200
PKY960T	0515-9200

## 11.02. Maximum Cable Lengths

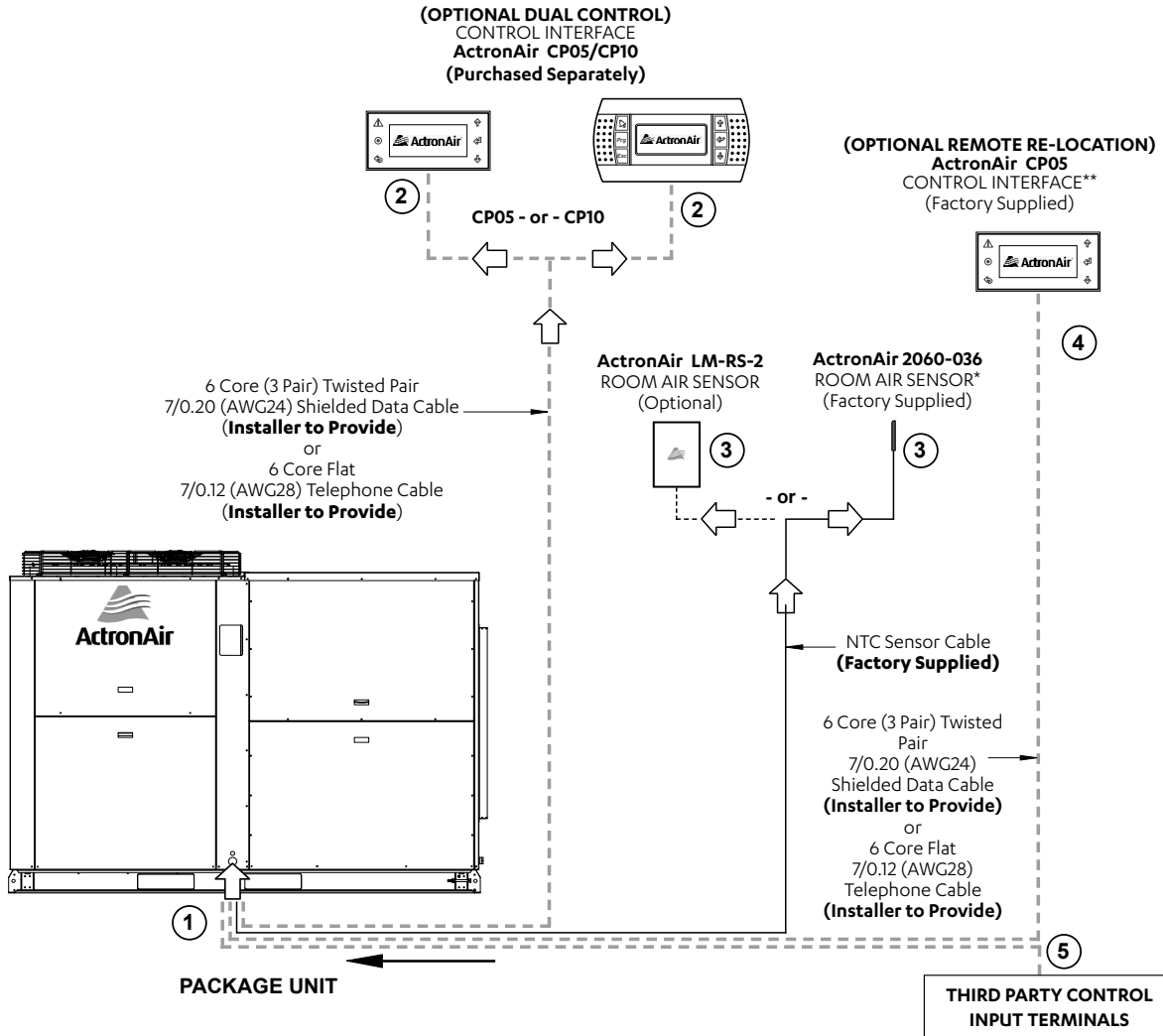

Item	Description	Suggested Maximum Cable Length
1 to 2	Outdoor CM100 to Optional ActronAir CP05 / CP10 Control Interface (Dual Control)	50m / 200m ***
1 to 3	Outdoor CM100 to Return Air Sensor (NTC Sensor Input Cable Size 0.5mm <sup>2</sup> / 1.0mm <sup>2</sup> )	50m / 100m
1 to 4	Outdoor CM100 to ActronAir CP05 (Remotely re-located Factory Supplied Control Interface)	50m / 200m***
1 to 5	Outdoor CM100 to Third Party Control	Refer to Third Party Control Supplier

### NOTES

- Diagram shown above is a general presentation only. Refer to individual unit wiring diagram for complete wiring connection details.
- Long cable runs beside supply mains or TV antenna cables should be avoided where possible.
- Room Air Sensor needs to be installed by the installer specific to site requirements.
- Suggested Maximum Cable Length: 50 m when using Flat Telephone Cable/200m when using 6 Core (3 Pair) Twisted Pair Shielded Data cable.
- For compliance with EMC requirements, connect screen wire to Terminal 22 on the Outdoor Panel.

\* Room Air Sensor is factory supplied with 6m cable as standard. Sensor may need adjustment for longer cable lengths.

\*\* Do not extend the factory supplied data cable when re-locating the Control Interface. Replace the cable with a single length of either of the data cables specified above.

\*\*\* Suggested Maximum Cable Length: 50m when using Flat Telephone Cable/200 m when using 6 Core (3 Pair) Twisted Pair Shielded Data cable.



## 11.03. BMS Control Installation Procedures

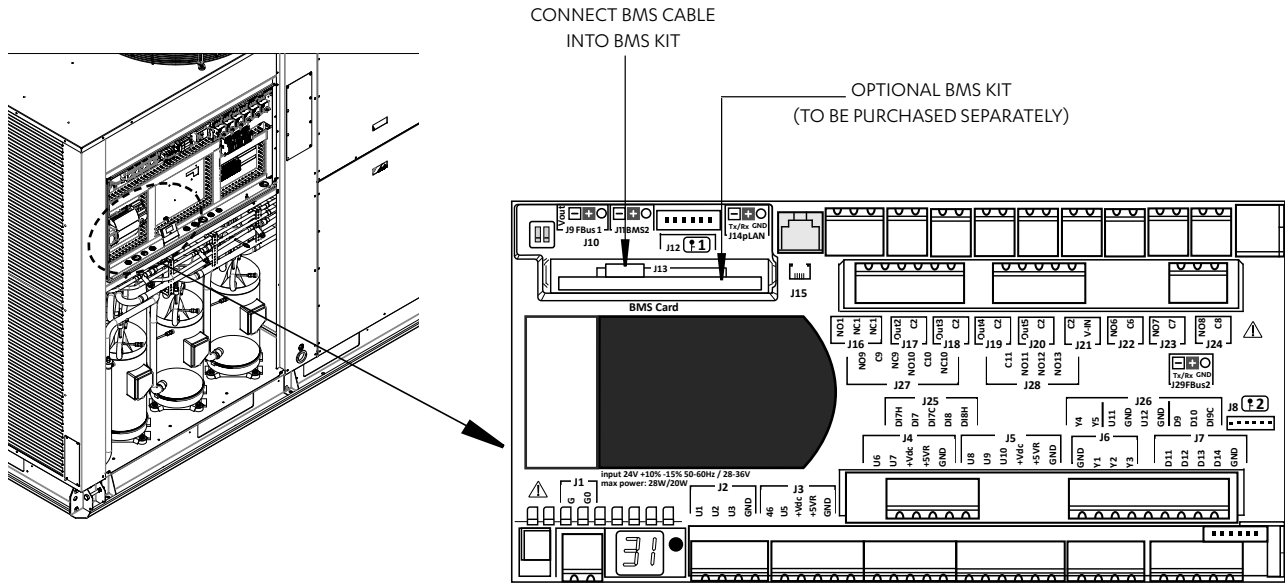

### NOTE

ActronAir Control Interface can be left connected or can be disconnected from the control board.

BMS PART NUMBERS		
BMS Connection Type	Kit Part Number *	Order Form**
MODBUS 485	ICMOD-485	Not required
BACNET 485	ICBAC-485	Document 1829
BACNET TCP/IP	ICBAC-TCP-IP	Document 1828

\* To be purchased separately.

\*\* It is necessary to complete and return the Order Form Document for BACNET cards (will be provided by Customer Care during ordering). The BACNET BMS cards are pre-programmed by ActronAir before being sent out.

### DANGER

#### Hazardous Voltage !

- Always make sure that all power supply, including remote controls, are disconnected before performing maintenance. Observe proper LOCK-OUT / TAG-OUT (LOTO) procedures to ensure that power cannot be inadvertently energised. Failure to disconnect power before maintenance procedures can result in serious injury or death.
- Follow all electrical safety precautions when exposed to live electrical components.
- Only qualified technicians are allowed to work on electrical circuits.
- All electrical wiring must be in accordance with the relevant electrical authority rules and regulations.

### CAUTION

#### STATIC SENSITIVE ELECTRONIC DEVICES !

- DO NOT handle electronic devices unless you are wearing an Anti-Static Wrist Strap that is connected to a GOOD EARTH. Failure to protect the electronic devices from static electricity may cause unreparable damage.
- Static damaged electronic devices are NOT COVERED for replacement under warranty.

## 11.04. Return Air - Outside Air - Spill Air Control Wiring Procedures

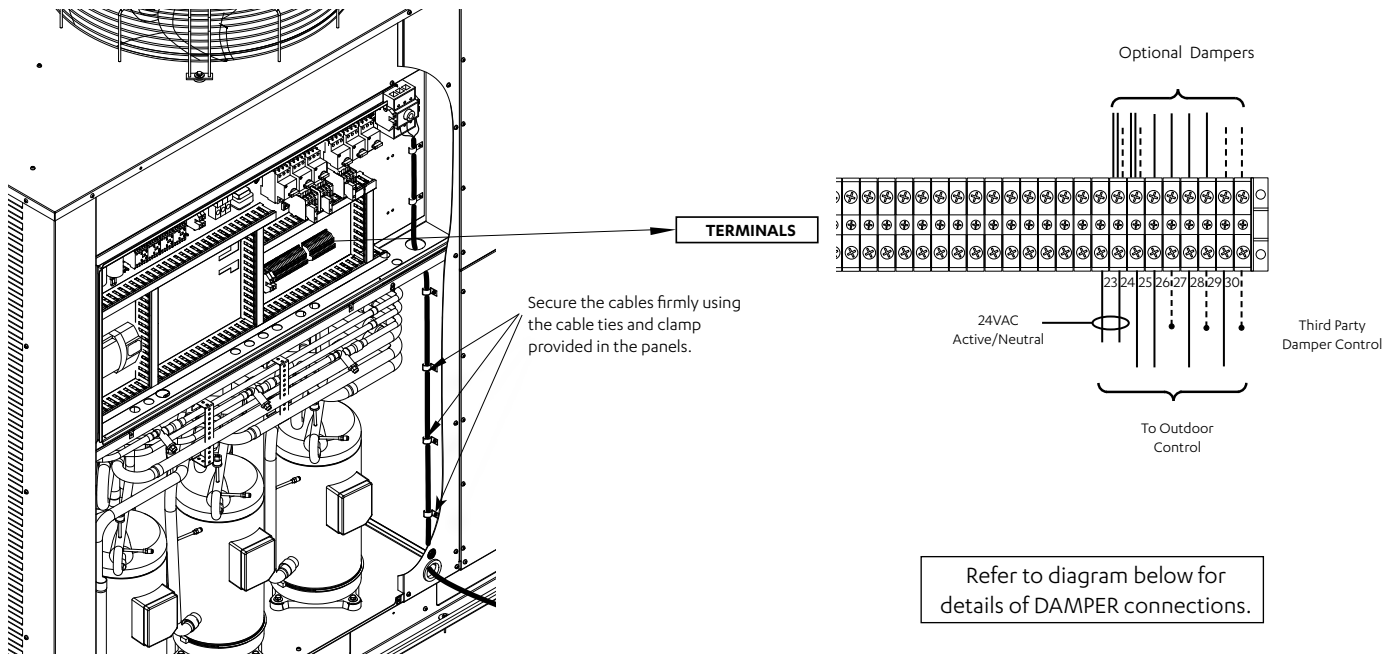

Refer to diagram below for details of DAMPER connections.

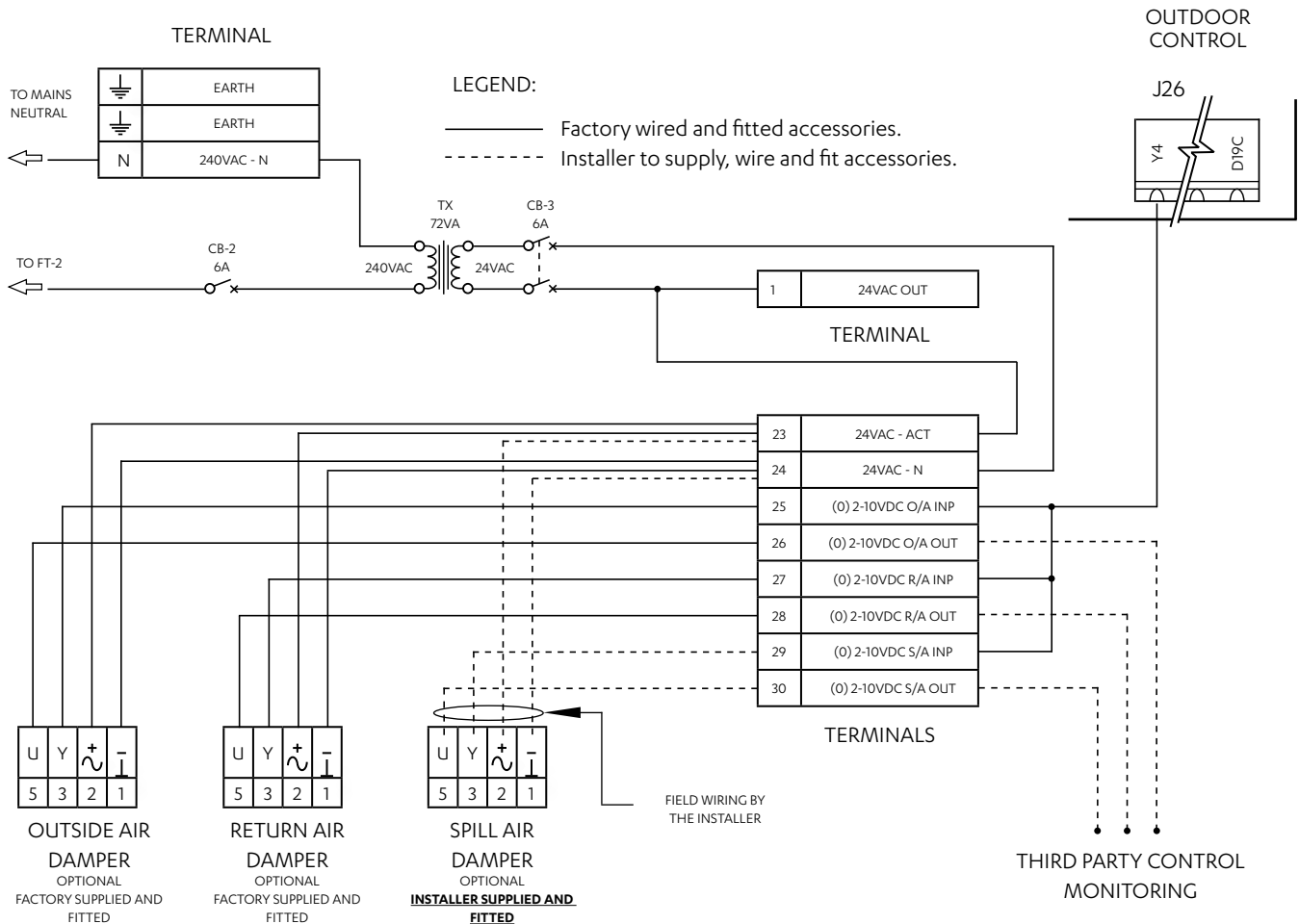

**RETURN AIR - OUTSIDE AIR - SPILL AIR CONTROL CONNECTION DIAGRAM**

## 11.05. Demand Response Management

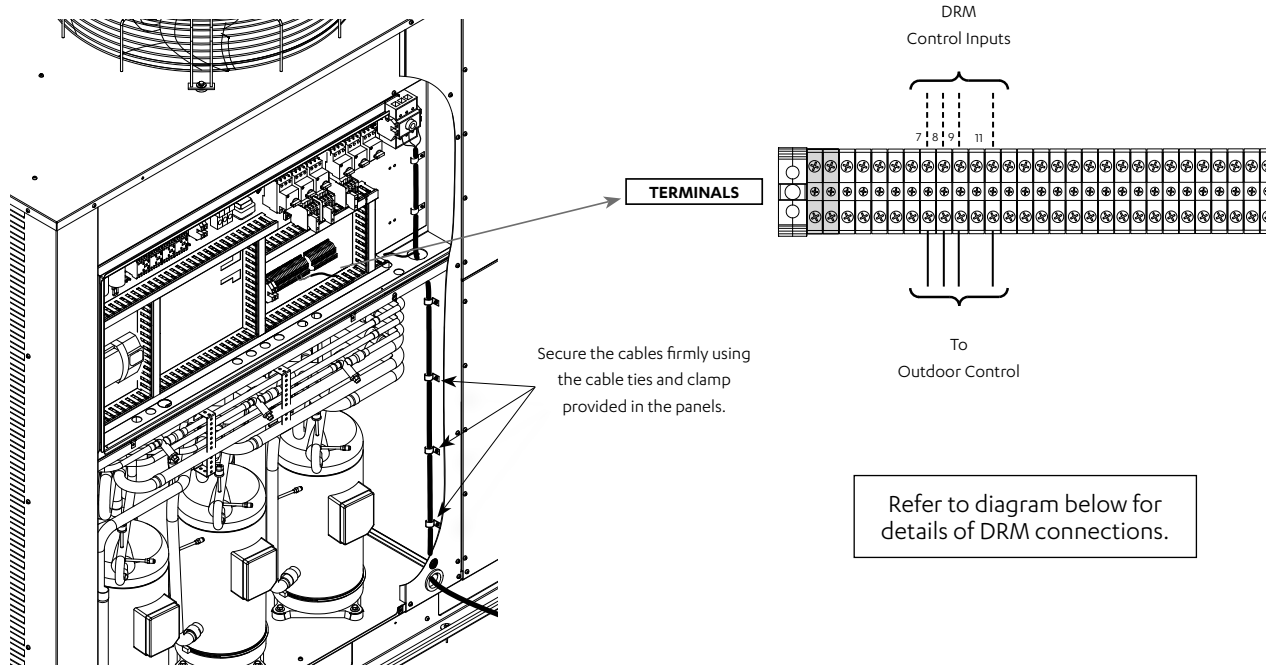

### 1. Thread and Route the DRM input cables into the Unit

- Thread and Route cables as per previous wiring installation procedures.

### 2. Connect cables into the terminals

- Connect cables as shown above and as per wiring diagram provided with the unit.

Demand Management Mode	Description of Mode	Operating Mode
DRM1	Compressor Off	Compressors ONLY will cycle OFF and remain off for the entire Demand Response Event.
DRM2	Maximum 50% power use mode. (Over each 1/2 hour period)	Compressor 1 operation only for the total Demand Response event.
DRM3	Maximum 75% input power use mode. (Over each 1/2 hour period)	Compressor 1 OR Compressor 2 and 3 operation only for the total Demand Response event. *

\* Depending on Heat Load requirement, i.e.

- 33% capacity demand, Compressor 1 only will be in operation.
- 67% capacity demand, Compressors 2 and 3 only will be in operation.

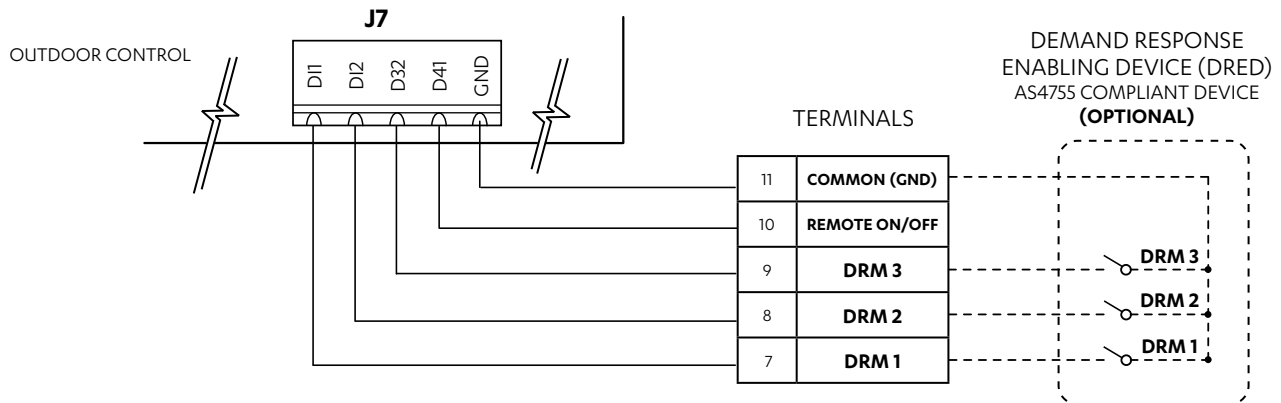

**DEMAND RESPONSE MANAGEMENT CONNECTION DIAGRAM**

## 12. CONTROL MENU

### 12.01. Menu Navigation

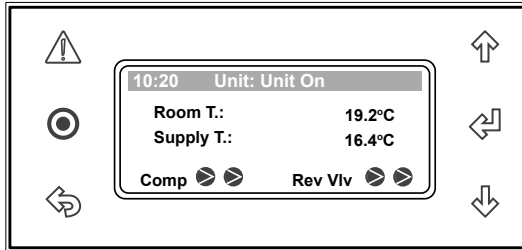

Pressing at anytime will bring the menu back one level up.  
 Pressing at anytime will bring back to the main menu.  
 Pressing will display an active alarm (if any).  
 Button will blink if any system alarm is active.

Example below will show the navigation to screen **Gfc2. Thermoregulat.**

**G. Service** → **Gf. Service settings** → **Gfc. Thermoregulation** → **Gfc2. Thermoregulat.**

**12.01.01.** To get into the main menu in the control interface, press . The display will show the list of available submenus. Press or Button to scroll through the sub menus and select **G. Service**. Press to enter the submenu.

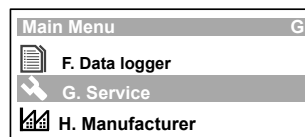
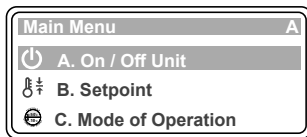

**12.01.02.** Press or Button to scroll to menu **Gf. Service settings** then press . Press or Button to scroll to menu **Gfc. Thermoregulation** then press .

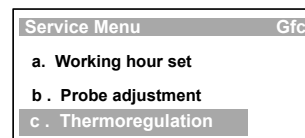
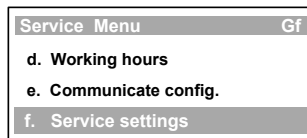

**12.01.03.** Press or Button to scroll to menu **Gfc2. Thermoregulat.** then press . Set the fields based on desired configuration.

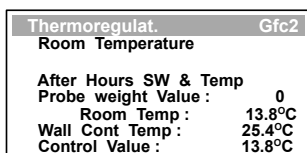

### 12.02. Service Password

To access the Service Settings pages a password is required: 7378

**G. Service** → **Gf. Service settings** → **Change password to 7378**

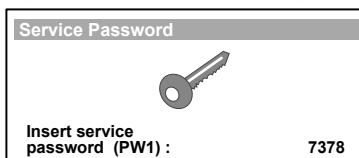

\* Service Password is shown.

#### WARNING

Unauthorized access to Service Menu and inadvertent changes to the settings can cause damage to the air conditioning system which will render ActonAir warranty null and void.

### 13. MENU TREE

**Note:** To scroll **Up** or **Down** from existing menu, press “↓” or “↑” Button.

#### 13.01. Main / Status Menu

\*Available when enabled via Service Menu.

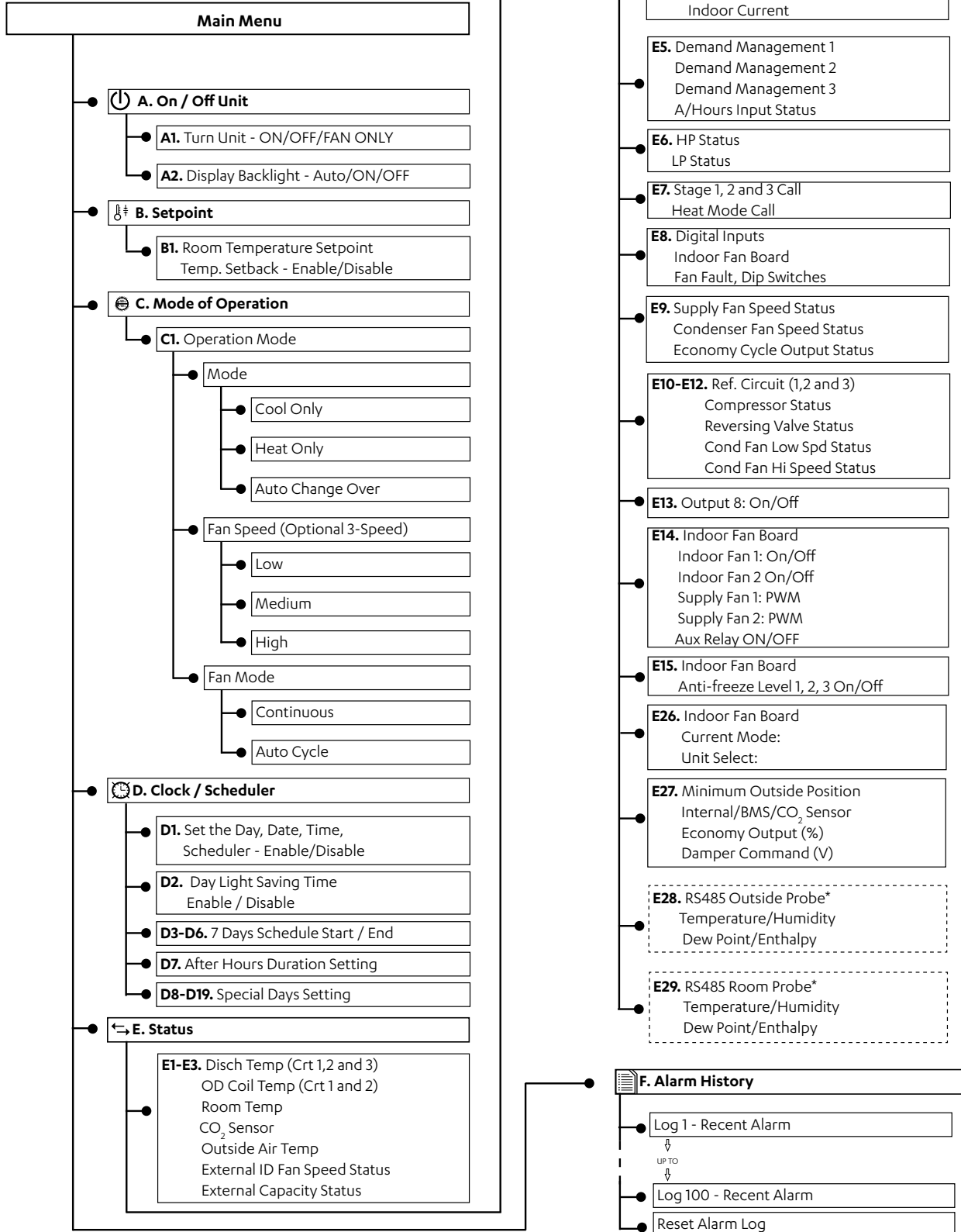

13.02. Service Menu

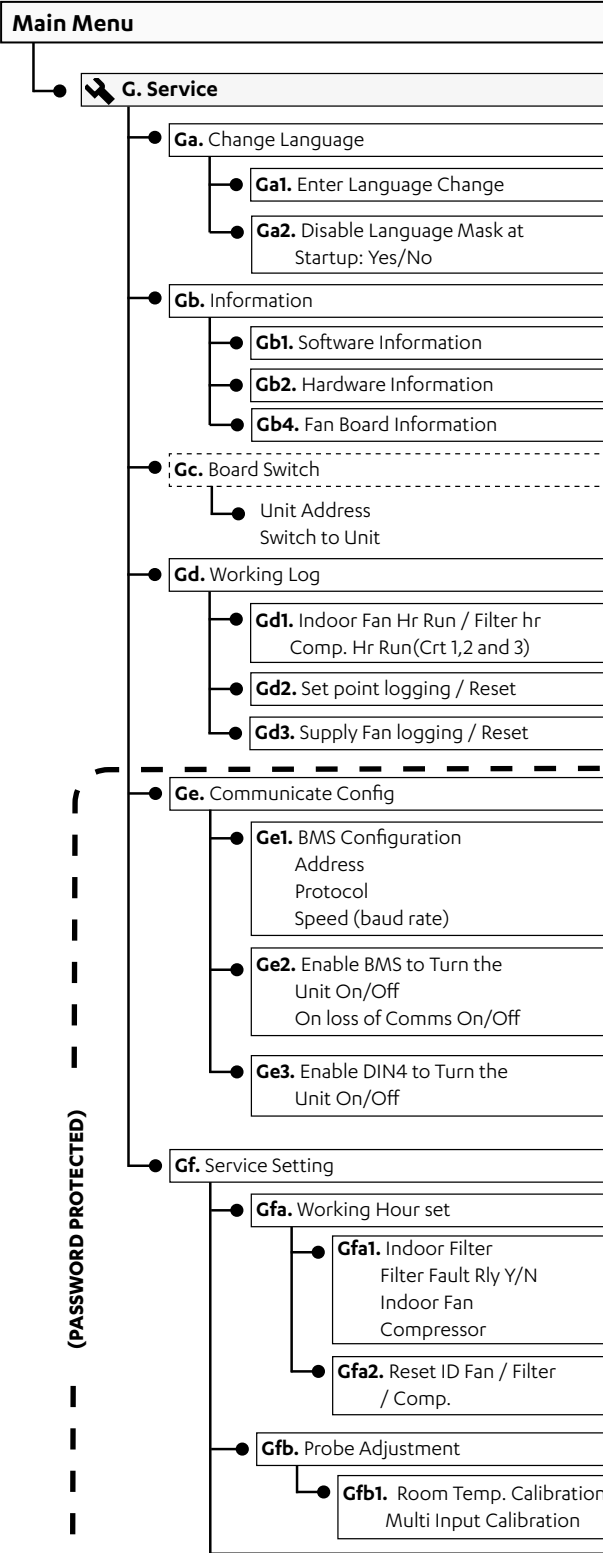

(PASSWORD PROTECTED)

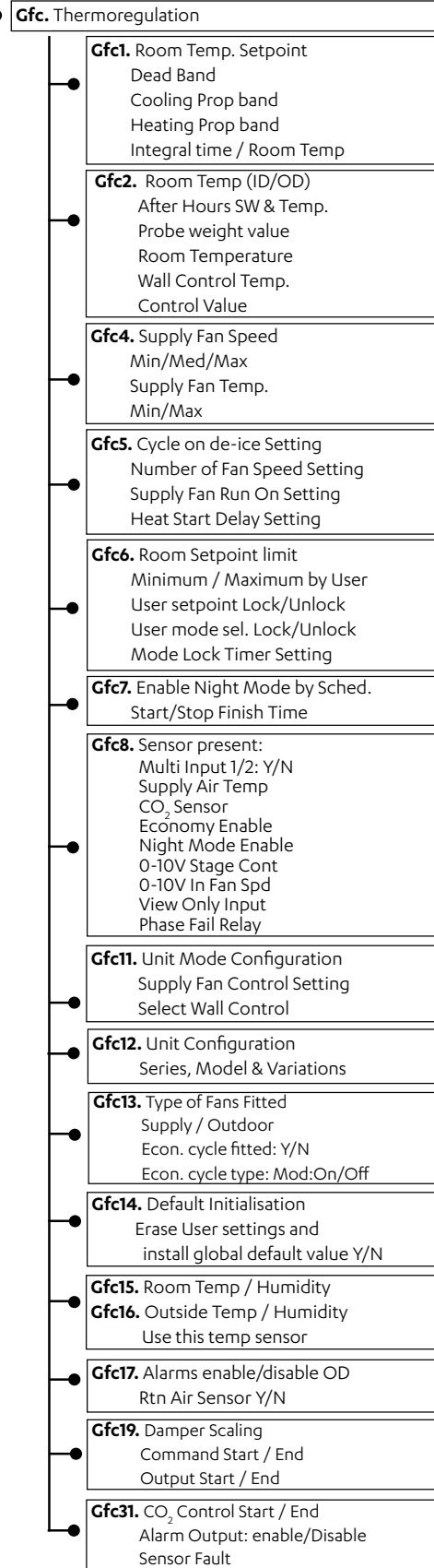

(PASSWORD PROTECTED)

(PASSWORD PROTECTED)

(PASSWORD PROTECTED)

(PASSWORD PROTECTED)

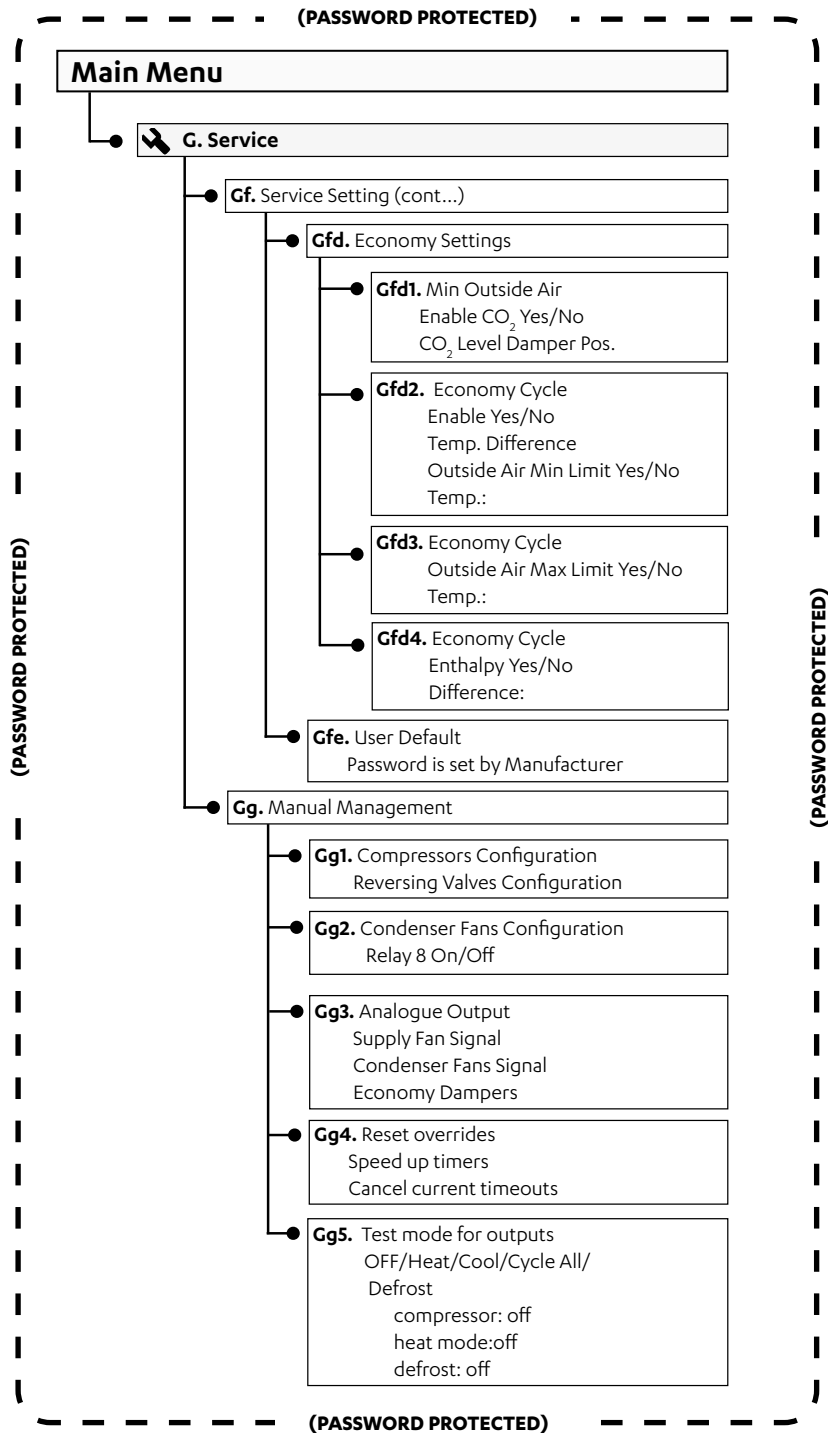

13.03. Manufacturer Menu

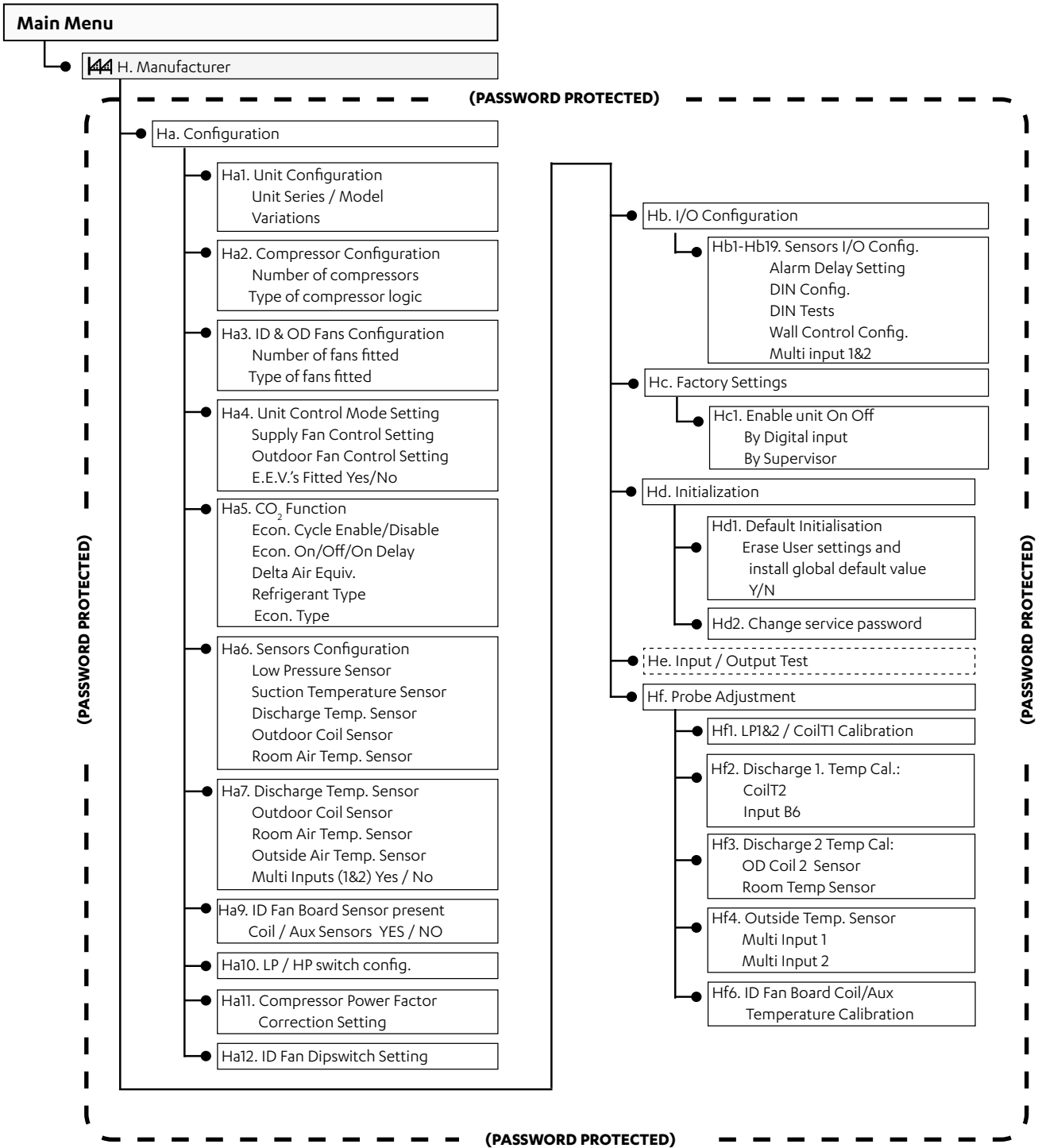



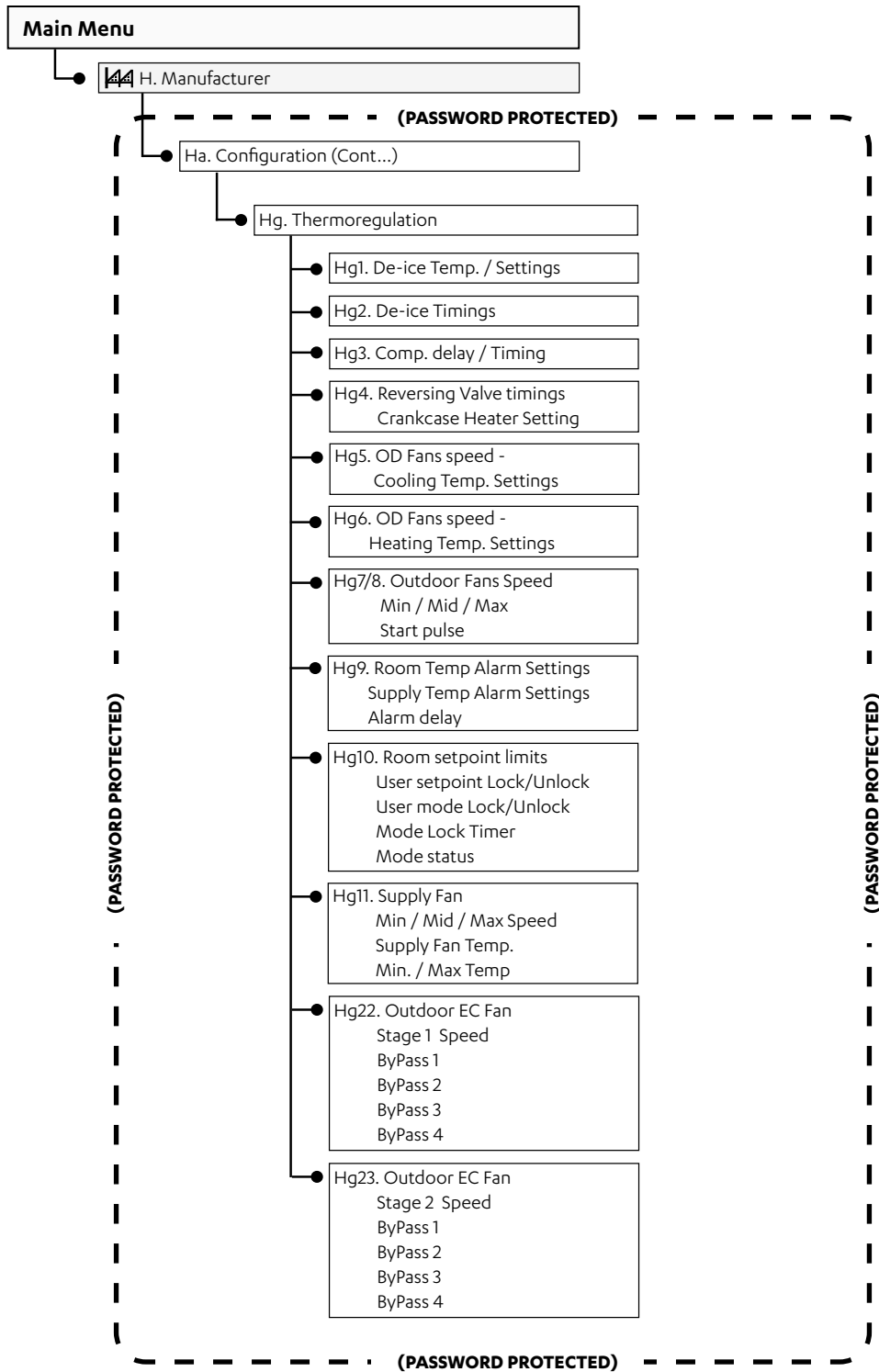

## 14. EXTERNAL INPUT OPERATION

The System is controlled by Third Party Control through wired inputs.

(On/Off, Indoor Fan, Compressor, Heat/Cool and Economy)

REMOTE ON/OFF can only be used when **Enable Scheduler** is set to **NO** (on screen D1).

### 14.01. Unit ON/OFF Configuration

The unit ON/OFF can be configured as follows:

#### 14.01.01. Wiring ON/OFF Input

Unit ON/OFF can be wired using either Method 1 (REMOTE ON/OFF) or Method 2 ( IN-FAN (24 VAC IN)) as shown below:

##### Method 1:

Unit ON/OFF is configured by switching REMOTE ON/OFF to COMMON.

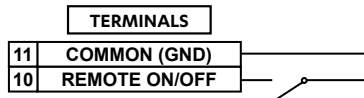

##### Method 2:

IN-FAN is operated by switching 24 VAC. The unit will turn On or Off when the switch is closed or open respectively.

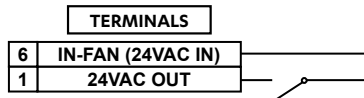

#### 14.01.02. Setting ON/OFF Input

Set **Enable DIN 4 to turn the unit On/Off** : to **Yes**.

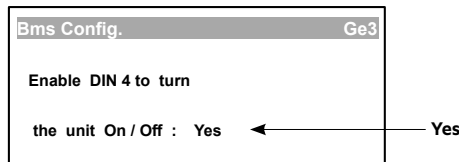

The Unit ON/OFF is now configured.

### 14.02. Indoor Fan External Control

Indoor Fans can be configured to be controlled via a 0-10VDC external input.

Follow the steps below:

#### NOTES

- Commissioning of the EC Fans should be carried out by a qualified technician only.
- Make sure that all instructions are followed accordingly.
- Ensure that connecting duct work and air filters are installed accordingly.

1. Refer to Section 22 for Fan Performance Data or the Fan Curve specific to your air conditioner.

- Determine the Required Fan Speed (%) which matches your Airflow and External Static Pressure requirements using either the Fan Performance Data or the Fan Curve.

**Example:**

Unit Model: **PKY820T**  
 Airflow: 4000 l/s  
 External Static Press: 100 Pa  
 Required Fan Speed: 60.4%

The Required Fan Speed shall be used to commission the indoor fan.

**Configuration Procedure:**

- On screen C1, set the **Fan Mode** to operate in either **Continuous** or **Auto cycle** (Auto cycle will cycle the indoor fans on/off with the compressor).

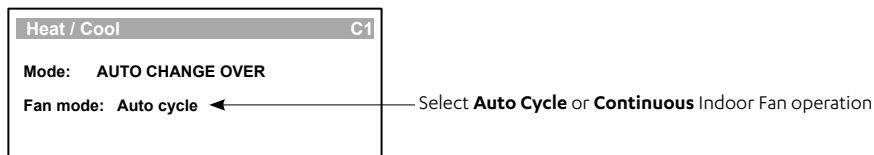

- Enable the Multi Input 1 (U11) to the Indoor Fans via S.Configuration screen Gfc8.

**G. Service → Gf. Service settings → Gfc. Thermoregulation → Gfc8. S. Configuration**

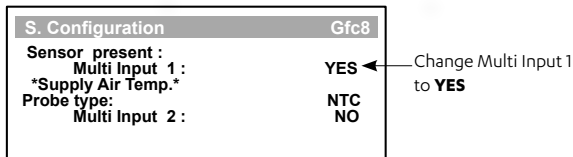

**NOTE:** Multi Input 2 (U12) can also be enabled, in lieu of Multi Input 1, if not used for other system Components.

- Configure Multi Input 1 (or Multi Input 2) to 0-10VDC Fan Speed and Probe type to 0-10V:

**G. Service → Gf. Service settings → Gfc. Thermoregulation → Gfc8. S. Configuration**

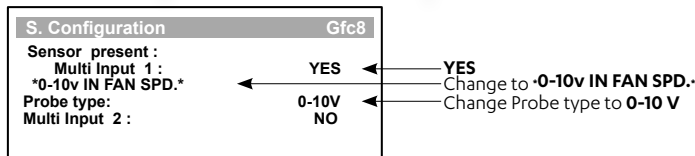

- Set the Supply Fan type to VARI SPEED via S.Configuration screen Gfc13:

**G. Service → Gf. Service settings → Gfc. Thermoregulation → Gfc13. S. Configuration**

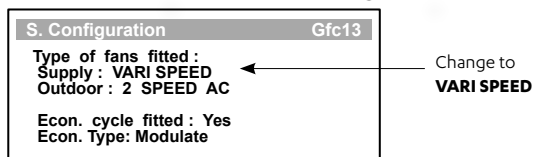

- e. Set the unit control mode to External input and set the Supply Fan Control to External via S.Configuration screen Gfc11:

G. Service → Gf. Service settings → Gfc. Thermoregulation → Gfc11. S. Configuration

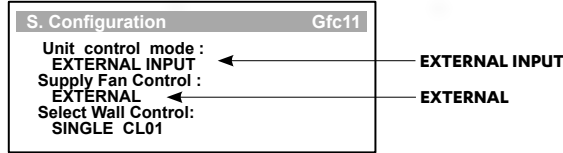

**NOTE:** The Indoor Fans are now configured/ready to be controlled through external 0-10VDC input.

**NOTES**

- Refer to Section 14.02 (a) Indoor Fan Operation Modes for configuring the Indoor Fans in either Continuous Mode or Auto Mode.
- If there is no voltage supplied to the indoor fan and it is selected as continuous, the fan will run on the minimum speed for the selected unit model when the unit is On.
- The requested external fan speed value will be displayed on the status menu as Voltage x 100.  
e.g. 5.9 volts will be displayed as 590 on the capacity screen

Main Menu → E. Status → E2. Input / Output

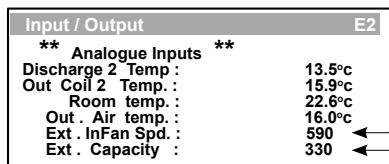

If the Indoor Fan External Control is set via Multi Input 1, the status screen will show **Ext. InFan Spd.**

If the Compressors 0-10VDC External Control Mode is set via Multi Input 2, the status screen will show **Ext. Capacity.**  
e.g. 330=3.3V or 33% Spd

**14.03. Compressor Configuration**

External input modes can be set up as per table below:

Component	External Input Configuration	Compressor Configuration Procedure	Wiring Diagram
Compressors	24VAC	14.03.01	22.01
	0-10VDC	14.03.02	22.02

To configure the External Input of Compressors control combination, perform the specific configuration procedure for the Compressors, as detailed below:

Unit control mode is set to **EXTERNAL INPUT** via Gfc11 screen.

G. Service → Gf. Service settings → Gfc. Thermoregulation → Gfc11. S. Configuration

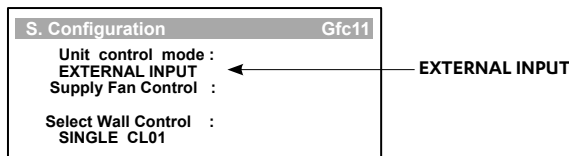

On screen C1, set the **Mode** to **Auto change over**, so the Third Party Control will have full control of the compressor operation.

By setting the mode to **Cool only** will restrict the compressor operation to **Cool only**.

By setting the mode to **Heat only** will restrict the compressor operation to **Heat only**.

Auto cycle will cycle the indoor fans on/off with the compressor.

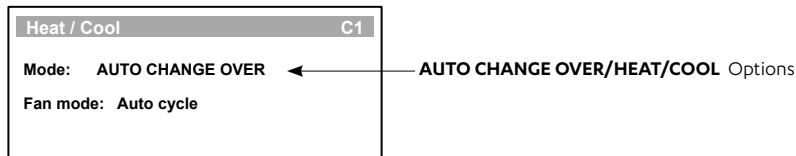

### 14.03.01. Compressors 24VAC External Control Mode

Compressors are configured through a 24VAC input from the external control. This is the **DEFAULT** compressor configuration. If this is the compressor external input requirement, no control interface configuration is required. Refer to the wiring diagram for wiring connection.

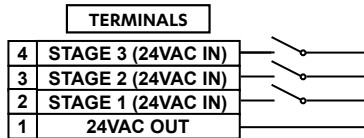

### 14.03.02. Compressors 0-10VDC External Control Mode

Compressors can be controlled through a 0-10VDC input from the external control.

#### NOTE

If a 0-10V input is required the multi-input must be changed as shown per procedure.

#### Compressors Configuration Procedure for 0-10VDC External Control Mode:

Assign a Multi Input to the Compressors via S.Configuration screen Gfc8:

**G. Service** → **Gf. Service settings** → **Gfc. Thermoregulation** → **Gfc8. S. Configuration**

Ensure that the Multi Input assigned to the Compressors is set to **\*0-10v STAGE CONT.\*** and the Probe type: is set to **0 - 10V**.

**G. Service** → **Gf. Service settings** → **Gfc. Thermoregulation** → **Gfc8. S. Configuration**

Example shown below is for Compressors with external input assigned to Multi Input 2:

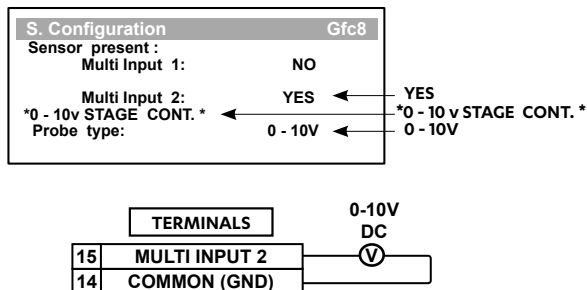

#### NOTE

For W-3 Phase Sequence Relay Option, Multi Input 2 (U12) is already used for 24VAC supply. Multi Input 1 (U11) must be used instead.

**Multi Input 1 and Multi Input 2 state**

Examples of equivalent voltage and capacity scaling are as follows:

3V = 33% capacity (stage 1); 6V = 66% capacity (stage 2); 9 = 100% capacity (stage 3)

**Main Menu → E. Status → E2. Input/Output**

Input / Output		E2
** Analogue Inputs **		
Discharge 2 Temp :	13.5°C	
Out Coil 2 Temp. :	15.9°C	
Room temp. :	22.6°C	
Out. Air temp. :	16.0°C	
Ext. InFan Spd. :	590	
Ext. Capacity :	330	

If Multi Input 1 is configured (as per Section 14.02 (b, c and d)), status will be shown as:  
External indoor fan speed set on the Third Party Control will be displayed.

If Multi Input 2 is configured (as per Section 14.03.02), status will be shown as:  
External capacity set on the Third Party control, as displayed on the Control Interface  
e.g. 330=3.3 V or 33% Spd

**14.03.03. Unit Heat Digital Input**

Heating is operated by switching 24VAC. The unit will run in heating when the switch is closed. Note that the compressor requires separate signal. Refer to Section 14.03.



**14.03.04. Economy Cycle On/Off Digital Input**

In this mode of Damper operation (On/Off), the damper will be:

1. Closed when the unit is OFF.
2. Open to **Max Outside Air Damper (100%)** position when **Multi Input 1** (or 2) is switched to GND (0V) and the unit is ON.
3. Open to **Min Outside Air Damper** position when **Multi Input 1** (or 2) is open (disconnected from GND (0V)) and the unit is ON.

Set the **Econ. type** to **ON/OFF** on Gfc13

S. Configuration		Gfc13
Type of fans fitted	3 SPEED (EC)	
Supply :	VARI SPEED	
Outdoor :	VARI SPEED	
Econ. cycle fitted :	Yes	
Econ. type :	ON / OFF	

Set up **Multi Input 1** (or 2) to **ECONOMY ENABLE** and **Probe type** to **ON/OFF** as shown below:

**G. Service → Gf. Service settings → Gfc. Thermoregulation → Gfc8 S. Configuration**

S. Configuration		Gfc8
Sensor present :	YES	
Multi Input 1 :	YES	
*ECONOMY ENABLE *	ECONOMY ENABLE	
Probe type:	ON/OFF	
Multi Input 2 :	NO	

Switch **Multi Input 1** (or 2) to **COMMON (GND)** to operate the Economy Cycle (Maximum Outside Air)

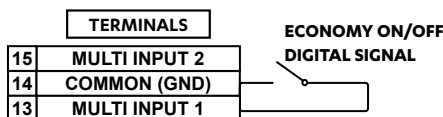

**14.03.05. Min. Outside Air:** (Configurable in Gfd1 screen)

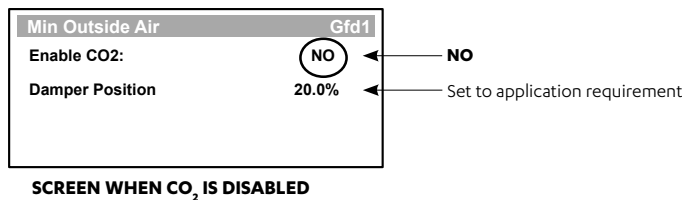

**15. INTERNAL SENSOR OPERATION**

The System is controlled by the ActronAir CM100 control.  
(On/Off, Indoor Fan, Compressor, Heat/Cool and Economy)

**15.01. Unit Control Configuration**

Set the unit control mode to **Internal Sensors** via Service menu:

**G. Service** → **Gf. Service settings** → **Gfc. Thermoregulation** → **Gfc11. S. Configuration**

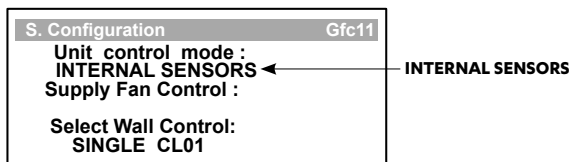

**15.02. Unit ON/OFF Configuration**

The unit ON/OFF can be configured to one of the following:

- Option 1:** MANUAL ON/OFF
- Option 2:** TIME SCHEDULER
- Option 3:** EXTERNAL UNIT ON/OFF

Unit status will be shown on the Main Menu. Screen below shows Unit status as Unit On.

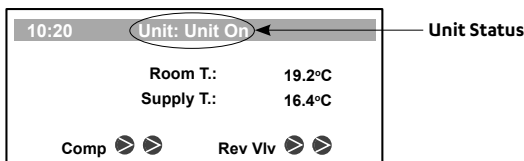

**Option 1: MANUAL ON/OFF**

Ensure that **Enable DIN 4 to turn the unit On/Off** : is set to **NO**.

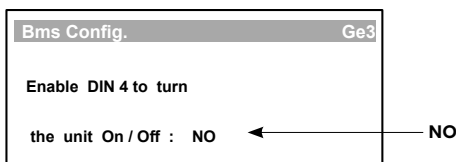

Turn On or Off the unit on screen A1 when required.

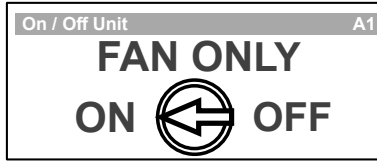

**NOTE**

Selecting **Fan Only** will turn on the supply fan without compressor operation.

The Unit ON/OFF is now configured.

Unit ON/OFF CP05 (CP10, CL01 optional)	Unit Status
ON	Unit On
OFF	OFF by KEY

**Option 2: TIME SCHEDULER**

Ensure that **Enable DIN 4 to turn the unit On/Off :** is set to **NO**.

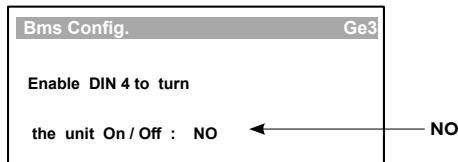

Ensure **Enable Scheduler** (on screen D1) must be **Yes**.

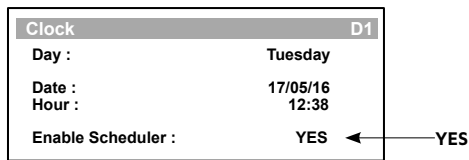

Then set the weekly, After Hours and special days time scheduler via screens (D3 – D19) to your requirements.

The Unit ON/OFF is now configured.

Unit ON/OFF CP05 (CP10, CL01 optional)	SCHEDULE	UNIT STATUS
ON	ON	Unit On
ON	OFF	OFF by SCH
OFF	ON or OFF	OFF by KEY



**Option 3: External Unit ON/OFF**

The Unit ON/OFF can be controlled via external relay.

Unit ON/OFF CP05 (CP10, CL01 optional)	REMOTE ON/OFF	UNIT STATUS
ON	ON	Unit On
ON	OFF	OFF by DIN
OFF	ON or OFF	OFF by KEY

**15.02.01. Wiring ON/OFF Input**

Unit ON/OFF can be wired using either **Method 1: External Unit ON/OFF** or **Method 2: IN-FAN (24VAC IN)**.

**Method 1: External Unit ON/OFF**

External Unit ON/OFF is operated by switching REMOTE ON/OFF to COMMON.

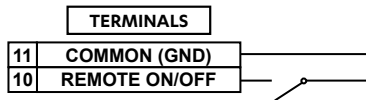

**Method 2: IN-FAN (24VAC IN)**

External Unit ON/OFF is operated by switching 24VAC to IN-FAN terminal.

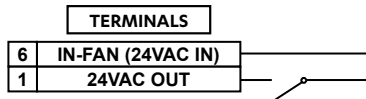

**15.02.02. Setting ON/OFF Input**

Set **Enable DIN 4 to turn the unit On/Off** (on screen Ge3) to **Yes**.

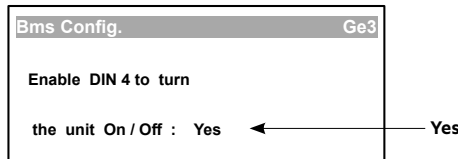

**Enable Scheduler** (on screen D1) must be **No**.

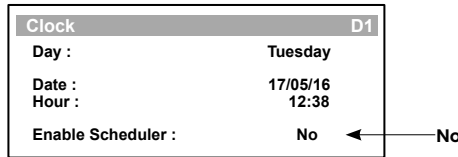

Ensure **ON/OFF Unit** (on screen A1) is **ON**.



The Unit ON/OFF is now configured.

15.03. Indoor Fan Configuration

**NOTES**

- Commissioning of the EC Fans should be carried out by a qualified technician only.
- Make sure that all instructions are followed accordingly.
- Ensure that connecting duct work and air filters are installed accordingly.

**Indoor EC Fan Speed setting/Commissioning Procedure via Control Interface**

1. Refer to the Fan Performance Data or the Fan Curve specific to your air conditioner.
2. Determine the Required Fan Speed (%) which matches your Airflow and External Static Pressure requirements using either the Fan Performance Data or the Fan Curve.

**Example:**

Unit Model: PKY820T

Airflow: 4000 l/s

External Static Press: 100 Pa

Required Fan Speed: 60.4%

3. Use this Required Fan Speed % to set the medium speed via the control interface, following the menu navigation:

**G. Service → Gfc. Service Settings → Gfc. Thermoregulation → Gfc4. Thermoregulat. (Supply Fan Settings).**

Thermoregulat.	Gfc4
Supply Fan	
Minimum speed:	49.0%
Medium speed:	71.9% ← % Medium Fan Speed
Maximum speed:	90.0%
Supply Fan Temp.	
Minimum Temp.:	5.0°C
Maximum Temp.:	50.0°C

**NOTES**

- Minimum and Maximum fan speeds are factory default settings.
- Medium fan speed is the nominal operating fan speed which can be adjusted between the minimum and maximum speed.

**16. SETTING UP BMS (REMOTE DEMAND) OPTIONAL**

For optional BMS (Remote Demand) Optional Mode, see Installation and Commissioning Guide (0525-036).

**17. SETTING ECONOMY CYCLE OPERATION**

The Economy mode is based on Dry Bulb Δt logic only and operates when cooling is required.

The conditions for Economy Cycle are required to be satisfied for a continuous period of 180s to start the Economy Cycle operation.

The Economy Cycle operation will continue to operate for at least 180s duration.

## 17.01. Setting Economy Cycle Type

The economy cycle operation can be set via the Control Interface as follow:

**G. Service** → **Gf. Service settings** → **Gfc. Thermoregulation** → **Gfc13 S. Configuration**

By default Econ. type is set to **MODULATE**. In this setting, ActronAir internal control logic modulates the damper positioning.

S. Configuration		Gfc13
Type of fans fitted		
Supply :	ACTRON A2FB	
Outdoor :	2 SPEED AC	
Econ. cycle fitted :	Yes	
Econ. type :	MODULATE	

### 17.01.01. Min Outside Air: (Configurable in Gfd1 screen)

Set the minimum damper positioning:

Min Outside Air		Gfd1
Enable CO2:	NO	
Damper Position	20.0%	

← This must be set to Application Requirements Range (0-99%)

To use ActronAir CO<sub>2</sub> sensor, refer to the document 9590-3011.

### 17.01.02. Enable Economy Cycle: (Configurable in Gfd2 screen)

To use the Economy Cycle logic, set Enabled to **YES** as shown below.

Economy Cycle		Gfd2
Enabled :	Yes	
Temperature Difference :	2.0c	
Outside Air Min Limit Temperature :	No	

← Yes

#### NOTE

Some options require 1 or 2 Humidity Sensors to be connected and setup.

### 17.01.03. Temperature difference to enable cycle: (Configurable in Gfd2 screen)

This setting is the difference required between the **Room Air Temp. (T<sub>Room</sub>)** and the **Outside Air Temp. (T<sub>Outside Air</sub>)**. For example, if (T<sub>Room</sub> - T<sub>Outside Air</sub>) Temperature Diff > 2.0°C (Default) then the economy cycle will be activated.

**Settings:** Min = -2.0°C, Max = 9.9°C, Default = 2.0°C

**17.01.04. Minimum Outside Air Temp.:** (Configurable in Gfd2 screen)

To use this option, set **Outside Air Min Limit Temperature** to **Yes**. If the  $T_{\text{Outside Air}} < \text{Outside Air Min Limit Temperature}$ , the economy cycle will stop, and the damper will remain open at the minimum opening value set by the **Min Outside pos**.

**Settings:** Min = 0.0°C, Max = 25.0°C, Default = 14.0°C

Economy Cycle		Gfd2
Enabled :	Yes	Yes
Temperature Difference :	2.0c	
Outside Air Min Limit Temperature :	Yes	14.0c

**17.01.05. Maximum Outside Air Temp.:** (Configurable in Gfd3 screen)

To use this option, set **Outside Air Max Limit Temperature** to **Yes**. If the  $T_{\text{Outside Air}} > \text{Outside Air Max Limit Temperature}$ , the economy cycle will stop, and the damper will remain open with maximum opening value set by **Min Outside pos**.

**Settings:** Min = 0.0°C, Max = 25.0°C, Default = 16.0°C

Economy Cycle		Gfd3
Outside Air Max Limit Temperature :	Yes	16.0c
Humidity :	No	
Enthalpy :	No	
Dew Point:	No	

**NOTE**

To use humidity sensor option in economy cycle, refer to Humidity Sensor Installation and Commissioning Guide.

**17.02. Calibration Damper Opening**

Damper Scaling: (Configurable in Gfc19)

The Damper opening calibration can be configured through Service Menu Gfc19.

This is pre-configured for 2-10V modulating damper motors.

The graph shows the conversion of Outside Air Damper Command (Start and End) to Output Voltage (Start and End) which is connected to the damper motor signal input.

This Output Voltage scaling is used for both Minimum Outside Air and Economy Cycle operation.

**NOTE**

The Output Voltage is set to 0V when the system is off.

Economy Cycle		Gf19
Damper Scaling		
Command Start:	0%	
Command End:	100%	
Output Start:	20%	
Output End:	100%	

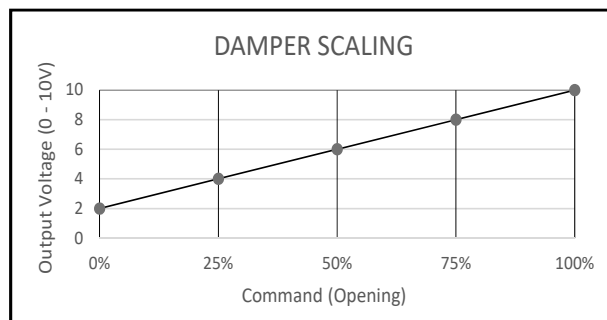

## 18. ROOM AIR TEMPERATURE SENSOR INSTALLATION

### NOTES

- Install the Room Air Temperature Sensor in the most suitable location to ensure adequate sensing.
- Ensure that the sensor is located where the room air is not affected by other heat sources.
- The Room Air Temperature Sensor must be properly secured in the chosen location.
- The Sensor wire should be routed securely and not to be exposed to sunlight, rain, dust and other contaminants.
- Ensure the sensor cable is ran separately to any low/high voltage cables to avoid interference.

### 18.01. Package Unit Air Temperature Sensor

The Room Air Temperature Sensor is not pre-installed with the unit. The Room Air Temperature Sensor is kept in the plastic pack together with installation manuals. To install the provided sensor;

- Take out the Room Air Temperature Sensor from the document pack.
- Strip the cable to expose the wires.

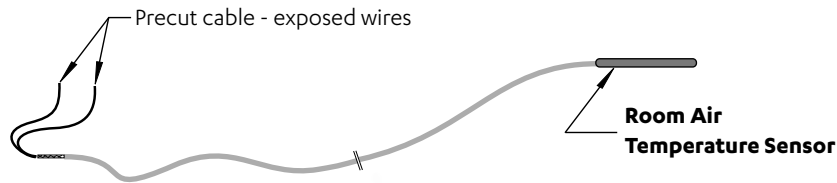

- Connect the sensor wires to the Outdoor Terminals:

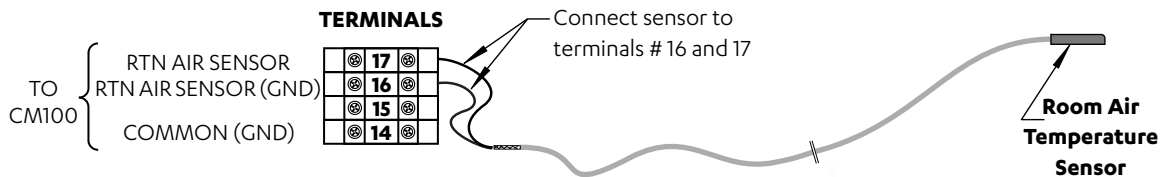

### NOTES

- The supplied Room Air Temperature Sensor (ActronAir Part Number: 2060-036) is a Duct Bead type sensor on the CP05/CP10 display. A wall type sensor is also available as an option (ActronAir Part Number: LM-RS).
- For longer installation requirements, it is possible to extend the provided 6m sensor lead wire with an extension wire. The extension wire **MUST** comply to the specifications on Section 19.01 and the installer is required to adjust the sensor to get proper reading.

## 19. ROOM AIR TEMPERATURE SETUP IN CONTROL INTERFACE

Below procedures show how to set up the air temperature sensors depending on terminal location.

### 19.01. Averaging Four Room Air Temperature Sensors (Optional)

Additional sensors may be purchased separately from ActronAir.

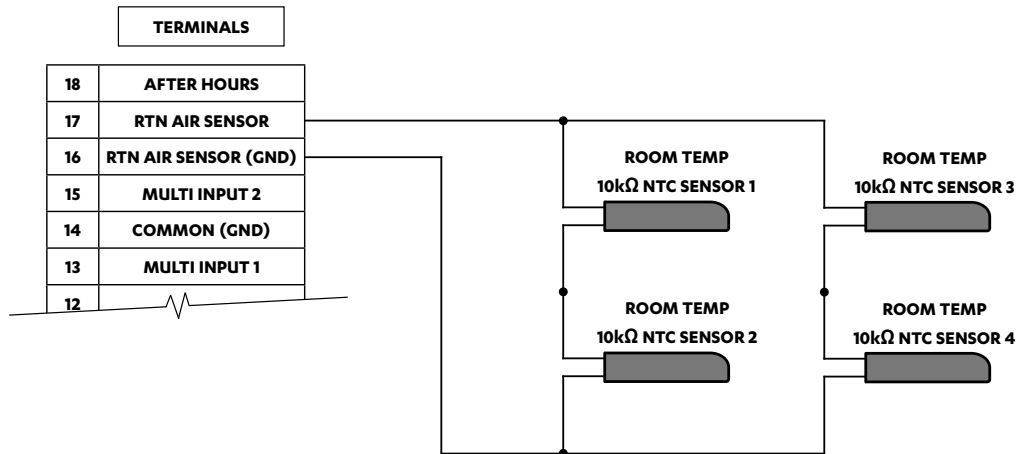

#### Specifications - Sensor Lead Wire

Item	Distance	
	up to 50m	up to 100m
NTC (Sensor Wire) *	0.5mm <sup>2</sup>	1.0mm <sup>2</sup>

\* For compliance with EMC requirements, connect the screen wire to Terminal 22 on the Outdoor Terminal Strip.

Use only the provided ActronAir duct bead sensor or the optional wall sensor.

Use of third party sensors are done at the contractors' risks and ActronAir accepts no responsibility for performance or sensing issues.

### 19.02. Setting up the Room Air Temperature

To setup the Room Air Temperature Sensor (connected to **RTN AIR SENSOR** and **RTN AIR SENSOR (GND)** terminals), ensure the **Probe weight Value** is set to **0** as shown below:

Enter G. Service Menu

**G. Service** → **Gf. Service settings** → **Gfc. Thermoregulation** → **Gfc2. Thermoregulat.**

Thermoregulat.		Gfc2
Room Temperature		
After Hours SW & Temp		
Probe weight Value	0	
Room Temp :	13.8°C	
Wall Cont Temp :	25.4°C	
Control Value :	13.8°C	

**19.03. Room Temperature Sensor Adjustment Instructions**

To calibrate the Room Air Temperature sensor, follow the service menu steps:

**G. Service** → **Gf. Service settings** → **Gfb. Probe adjustment** → **Gfb1. Calibration**

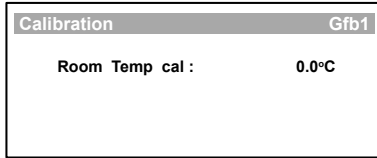

**Example:**

If the actual measured room temperature is 2.0°C higher than control interface reading, adjust the offset to -2.0°C. Adjustable offset range is from -9.9 °C to +9.9 °C.

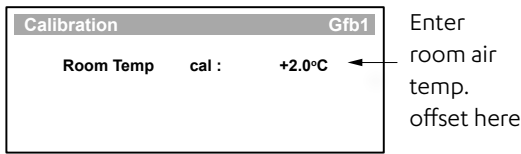

Probe Adjustment Display

**20. AFTER HOURS LOGIC WITH TIMECLOCK (SCHEDULER)**

**20.01. After Hours wiring to the unit**

**Option 1 :** After Hours button wired to the unit.

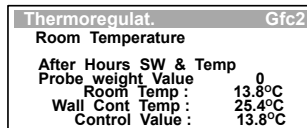
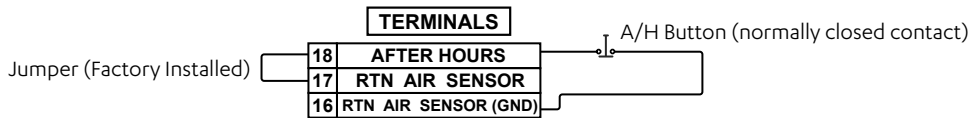

Use this option if using Indoor/CL01 sensor

**Option 2 :** After Hours button with Room Air Temperature Sensor wired to the unit.

Remove Jumper (Factory installed) wire from terminal 17 and 18.

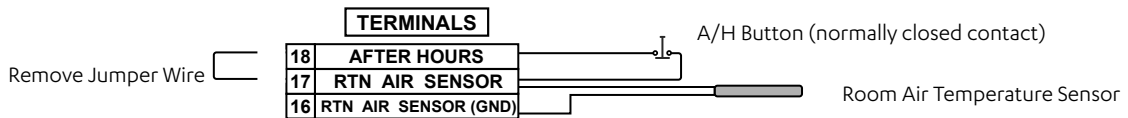

**20.02. Operational Logic**

If the scheduler is enabled, the After Hours function will start when the **AFTER HOURS** button is pressed and held for 5 seconds.

## 21. ENABLE / DISABLE AIR FILTER ALARM

The Tri-Capacity control gives the user the option to Enable / Disable the Air Filter Alarm.

### Procedure:

1. Set the **Indoor Filter** alarm timer in hours. Adjustable range is 0-900 hours.

**G. Service** → **Gf. Service settings** → **Gfa. Working hour set** → **Gfa1. Work. hours set**

Work. hours set	Gfa1
Indoor Filter:	200h
Filter Fault relay:	No
Indoor Fan :	10000h
Compressor :	10000h

Setting **Indoor Filter** to **000h** will disable the filter alarm and notification. At this setting, the output fault relay will not be energised.

2. To enable the Alarm Relay Output (Air Filter cleaning) notification, Set **Filter Fault Relay** to Yes.

**G. Service** → **Gf. Service settings** → **Gfa. Working hour set** → **Gfa1. Work. hours set**

Work. hours set	Gfa1
Indoor Filter:	200h
Filter Fault relay :	Yes
Indoor Fan :	10000h
Compressor :	10000h



## 22. EXTERNAL INPUT WIRING DIAGRAMS

### 22.01. 24VAC Relay Output Compressors and Indoor Fans

#### TRI-CAPACITY CM100 COMMERCIAL CONTROLS 3RD PARTY THERMOSTAT CONTROLLER CONNECTION 24VAC RELAY OUTPUT FOR COMPRESSOR & INDOOR FAN

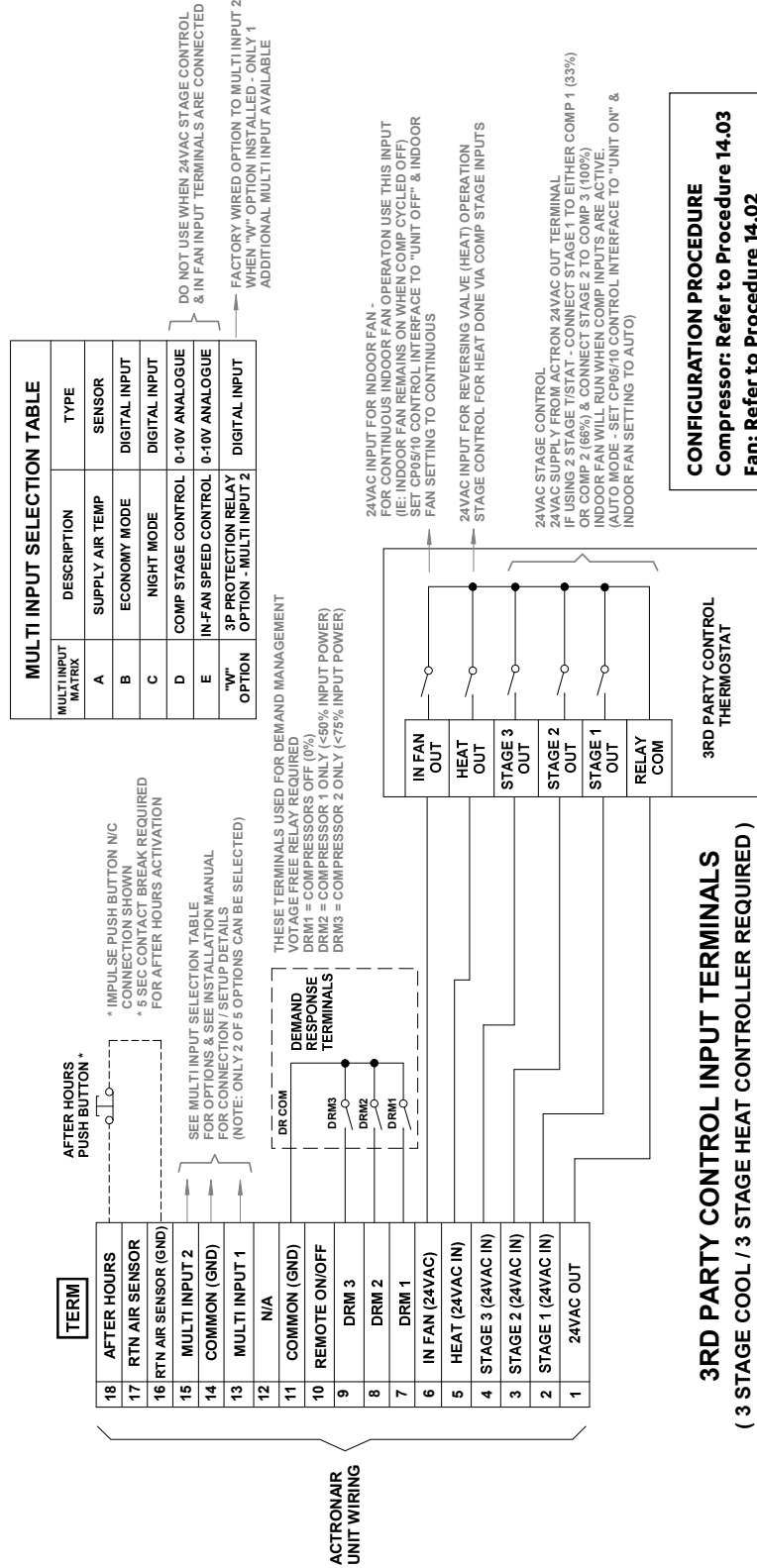

22.02. 0-10 Analogue Output Compressor and 24VAC Relay Output Indoor Fans

TRI-CAPACITY CM100 COMMERCIAL CONTROLS  
3RD PARTY THERMOSTAT CONTROLLER CONNECTION  
0-10V ANALOGUE OUTPUT FOR COMPRESSOR & 24VAC RELAY OUTPUT FOR INDOOR FAN

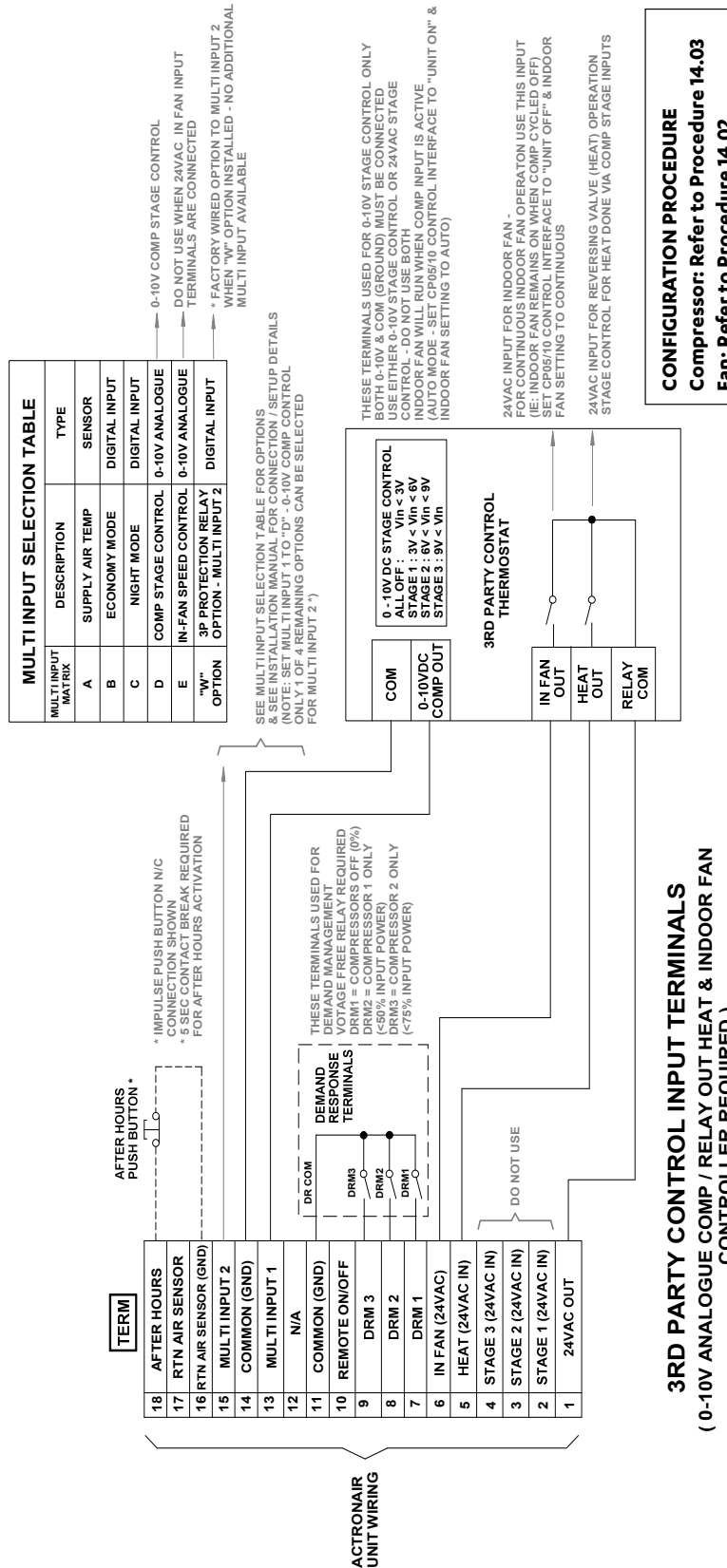

## 22.03. 24VAC Relay Output Compressor and 0-10 Analogue Output Indoor Fans

### TRI-CAPACITY CM100 COMMERCIAL CONTROLS 3RD PARTY THERMOSTAT CONTROLLER CONNECTION 24VAC RELAY OUTPUT FOR COMPRESSOR & 0-10V ANALOGUE OUTPUT FOR INDOOR FAN

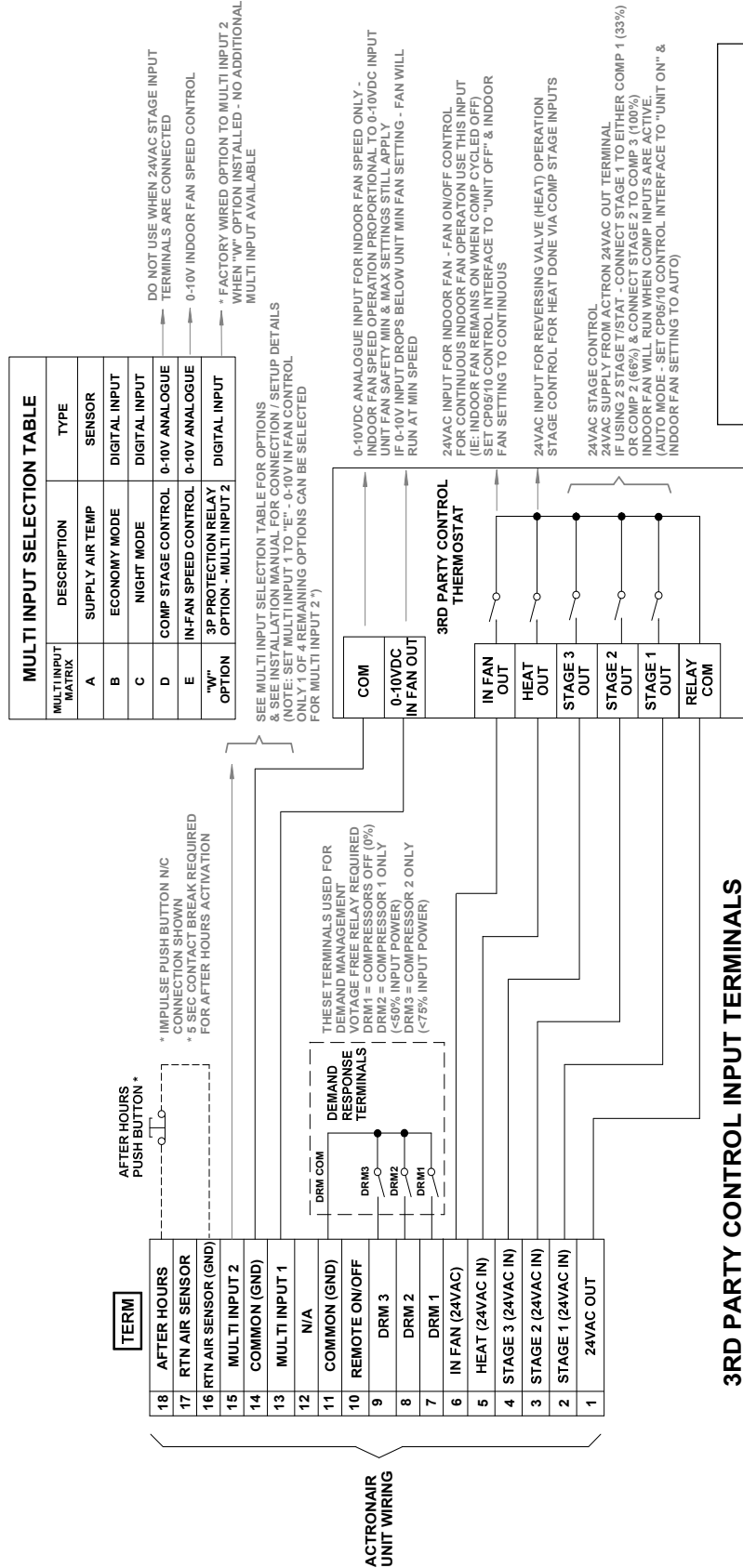

22.04. Wiring Diagram 0-10 Analogue Output Compressors and Indoor Fans

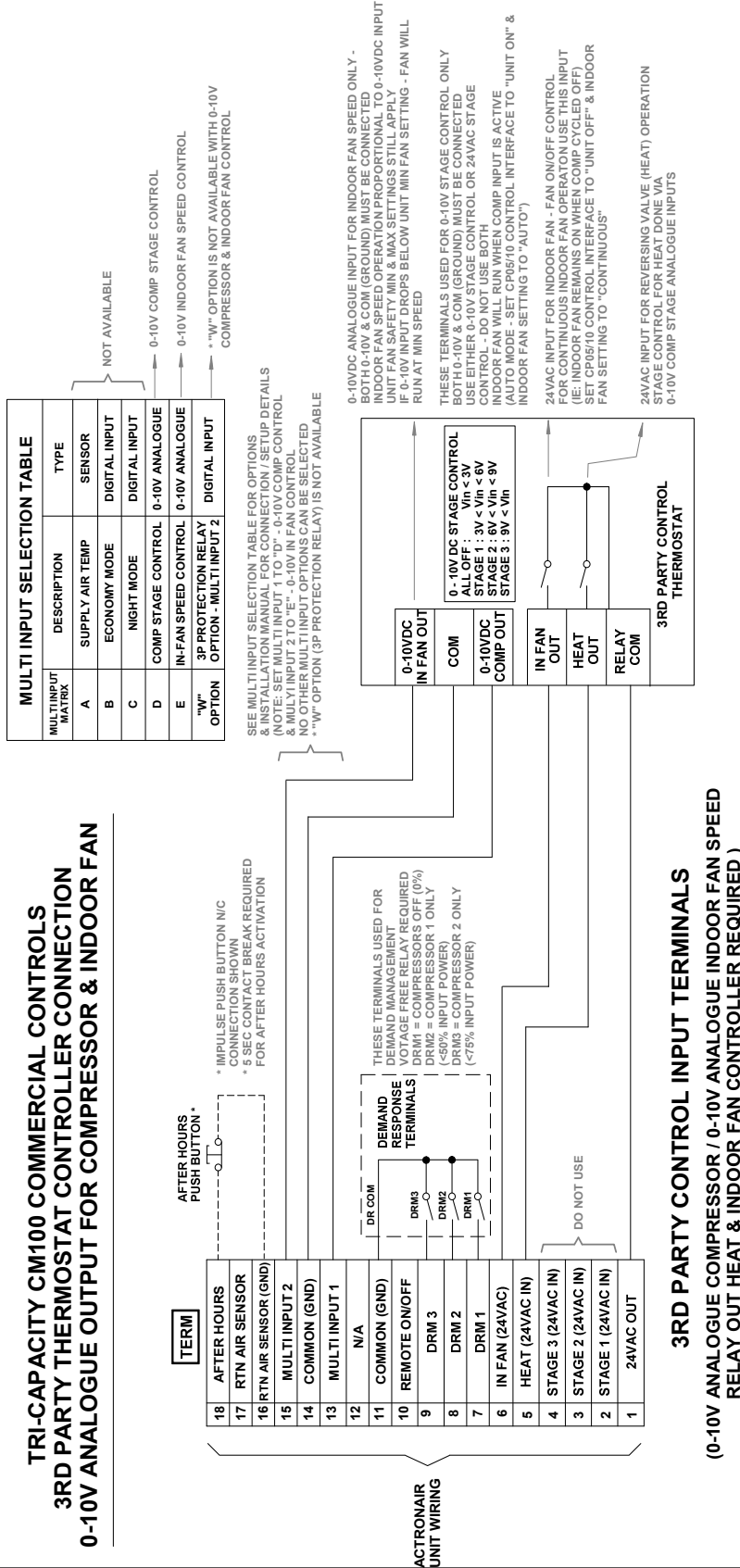

**CONFIGURATION PROCEDURE**  
Compressor: Refer to Procedure 14.03  
Fan: Refer to Procedure 14.02

### 23. FAN PERFORMANCE DATA AND CURVE

FAN PERFORMANCE DATA

PKY820T

AIRFLOW (l/s)	EXTERNAL STATIC PRESSURE (Pa)																			
	50		100		150		200		250		300		350		400		450		500	
	% Spd.	W	% Spd.	W	% Spd.	W	% Spd.	W	% Spd.	W	% Spd.	W	% Spd.	W	% Spd.	W	% Spd.	W	% Spd.	W
3200	48.7	958	51.4	1153	54.3	1412	57.7	1665	60.9	1895	64.8	2188	67.6	2477	70.5	2792	73.3	3136	76.2	3457
3300	49.6	997	52.2	1216	55.2	1480	59.0	1757	62.1	1988	65.6	2270	68.5	2580	71.1	2876	74.1	3247	77.1	3558
3400	50.7	1064	53.5	1319	56.6	1574	60.0	1828	63.3	2080	66.5	2370	69.3	2668	72.7	3079	75.0	3366	78.0	3659
3500	51.8	1147	54.4	1389	57.8	1658	61.1	1910	64.4	2164	67.3	2459	70.3	2789	72.8	3097	76.0	3468	79.0	3770
3600	52.7	1214	55.5	1469	59.0	1738	62.2	1989	65.4	2254	68.4	2584	71.1	2894	73.9	3237	77.0	3575	80.1	3802
3700	53.7	1292	56.8	1554	60.1	1808	63.3	2071	66.1	2331	69.2	2672	72.0	3004	74.8	3346	78.1	3692	81.0	4020
3800	54.7	1367	57.9	1623	61.2	1888	64.3	2151	67.2	2452	70.2	2784	72.9	3113	75.8	3452	79.1	3800	82.0	4161
3900	56.0	1456	58.9	1691	62.3	1976	65.5	2261	68.2	2560	71.3	2916	74.1	3252	77.0	3580	80.3	3950	82.9	4299
4000	57.3	1539	60.4	1795	63.5	2067	66.6	2376	69.3	2677	72.2	3017	75.1	3362	78.3	3730	81.1	4072	83.7	4421
4100	58.6	1629	61.6	1877	64.7	2153	67.7	2485	70.5	2804	73.3	3134	76.1	3467	79.4	3863	82.1	4219	84.6	4558
4200	60.0	1705	62.9	1972	65.9	2267	68.6	2572	71.6	2920	74.4	3254	77.5	3638	80.5	4017	82.9	4339	85.8	4735
4300	61.5	1821	64.2	2075	67.1	2389	69.7	2686	71.6	2909	75.5	3375	78.7	3791	81.5	4163	84.0	4500	87.0	4923
4400	62.6	1892	65.3	2160	68.1	2488	70.9	2810	73.8	3150	76.6	3509	79.9	3961	82.4	4295	84.8	4615	88.8	5191
4500	63.9	1988	66.6	2289	69.2	2596	72.1	2934	75.0	3270	77.9	3681	80.8	4085	83.3	4418	81.1	4125		
4600	65.0	2075	67.8	2408	70.5	2728	73.3	3053	76.1	3411	79.1	3849	81.8	4223	84.1	4534	87.9	5077		
4700	66.2	2192	69.0	2522	71.8	2851	74.5	3167	77.6	3615	80.3	4016	82.8	4360	85.5	4734	89.5	5313		
4800	67.5	2315	70.4	2657	73.1	2973	75.8	3319	78.7	3767	81.2	4135	83.8	4495	86.9	4941				

NOTES:

% Speed = Indoor Fan Speed Control Setting, in percent  
(Value is set on the Control Interface via Service Menu \*).

W = Indoor Fan Power, Watts

60.4 - Data in the box indicates Factory Default Setting.

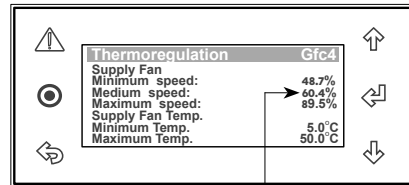

\*Service → Service Settings → Thermoregulation → Thermoregulation Gfc4

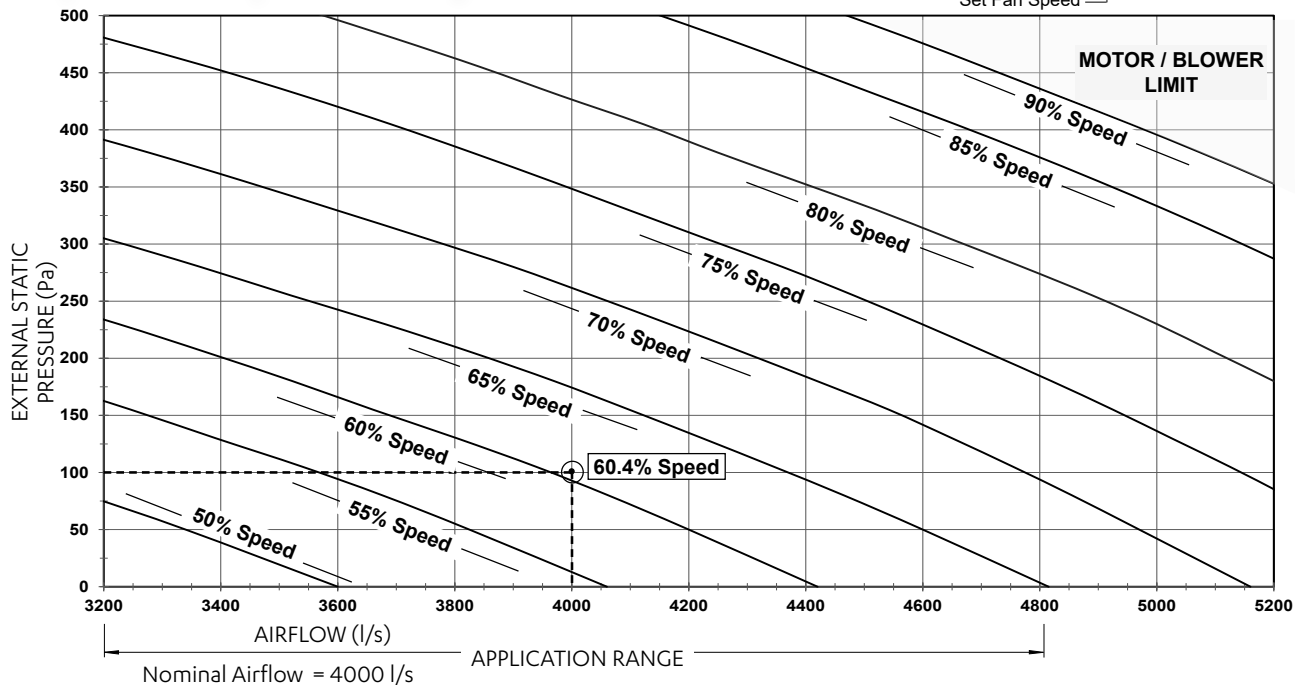

NOTES

Fan Performance Data and Fan Curve shown is at dry coil and with no air filters installed. Consider ext. static pressure drop specific to your design requirements.

## FAN PERFORMANCE DATA

PKY960T

AIRFLOW (l/s)	EXTERNAL STATIC PRESSURE (Pa)																			
	50		100		150		200		250		300		350		400		450		500	
	% Spd.	W	% Spd.	W	% Spd.	W	% Spd.	W	% Spd.	W	% Spd.	W	% Spd.	W	% Spd.	W	% Spd.	W	% Spd.	W
4000	57.3	1539	60.4	1795	63.5	2067	66.6	2376	69.3	2677	72.2	3017	75.1	3362	78.3	3730	81.1	4072	83.7	4421
4100	58.6	1249	61.6	1877	64.7	2153	67.7	2485	70.5	2804	73.3	3134	76.1	3467	79.4	3863	82.1	4219	84.6	4558
4200	60.0	1705	62.9	1972	65.9	2267	68.6	2572	71.6	2920	74.4	3254	77.5	3638	80.5	4017	82.9	4339	85.8	4735
4300	61.5	1821	64.2	2075	67.1	2389	69.7	2686	71.6	2909	75.5	3375	78.7	3791	81.5	4163	84.0	4500	87.0	4293
4400	62.6	1892	65.3	2160	68.1	2488	70.9	2810	73.8	3150	76.6	3509	79.9	3961	82.4	4295	84.8	4615	88.8	5191
4500	63.9	1988	66.6	2289	69.2	2596	72.1	2934	75.0	3270	77.9	3681	80.8	4085	83.3	4418	81.1	4125		
4600	65.0	2075	67.8	2408	70.5	2728	73.3	3053	76.1	3411	79.1	3849	81.8	4223	84.1	4534	87.9	5077		
4700	66.2	2192	69.0	2522	71.8	2851	74.5	3167	77.6	3615	80.3	4016	82.8	4360	85.5	4734	89.5	5313		
4800	67.5	2315	70.4	2657	73.1	2973	75.8	3319	78.7	3767	81.2	4135	83.8	4495	86.9	4941				
4900	69.0	2458	71.7	2776	74.4	3094	77.1	3495	79.8	3919	82.3	4277	84.7	4617	88.7	5211				
5000	70.4	2587	73.0	2891	75.8	3255	78.5	3692	81.2	4108	83.5	4439	86.2	4837						
5100	71.8	2706	74.3	3006	77.1	3437	79.7	3866	82.2	4236	84.5	4572	88.1	5121						
5200	73.7	2891	75.8	3186	78.3	3611	81.0	4047	83.2	4370	86.0	4790	89.8	5377						
5300	74.6	2960	77.2	3386	79.8	3831	82.1	4184	84.4	4534	87.8	5059								
5400	76.0	3143	78.5	3576	80.9	3975	83.2	4334	85.8	4739	89.5	5314								
5500	77.0	3268	80.0	3790	82.2	4146	84.5	4519	87.8	5038										
5600	78.9	3556	81.5	3998	83.2	4278	86.0	4735	89.5	5294										
5700	80.3	3756	82.5	4130	84.6	4487	88.0	5038												
5800	81.8	3967	83.7	4297	86.5	4766	89.9	5319												
5900	83.0	4134	84.9	4472	88.4	5051														
6000	84.1	4280	86.8	4746																

MOTOR / BLOWER LIMIT

**NOTES:**

% Speed = Indoor Fan Speed Control Setting, in percent  
(Value is set on the Control Interface via Service Menu \*).  
W = Indoor Fan Power, Watts  
[ ] - Data in the box indicates Factory Default Setting.

The screenshot shows a control interface for 'Thermoregulation Gfc4'. It lists the following settings: Supply Fan, Minimum speed: 57.3%, Medium speed: 73.0%, Maximum speed: 89.9%, Supply Fan Temp. Minimum Temp: 5.0°C, and Maximum Temp: 50.0°C. A 'Set Fan Speed' button is visible at the bottom right.

\*Service → Service Settings → Thermoregulation → Thermoregulation Gfc4

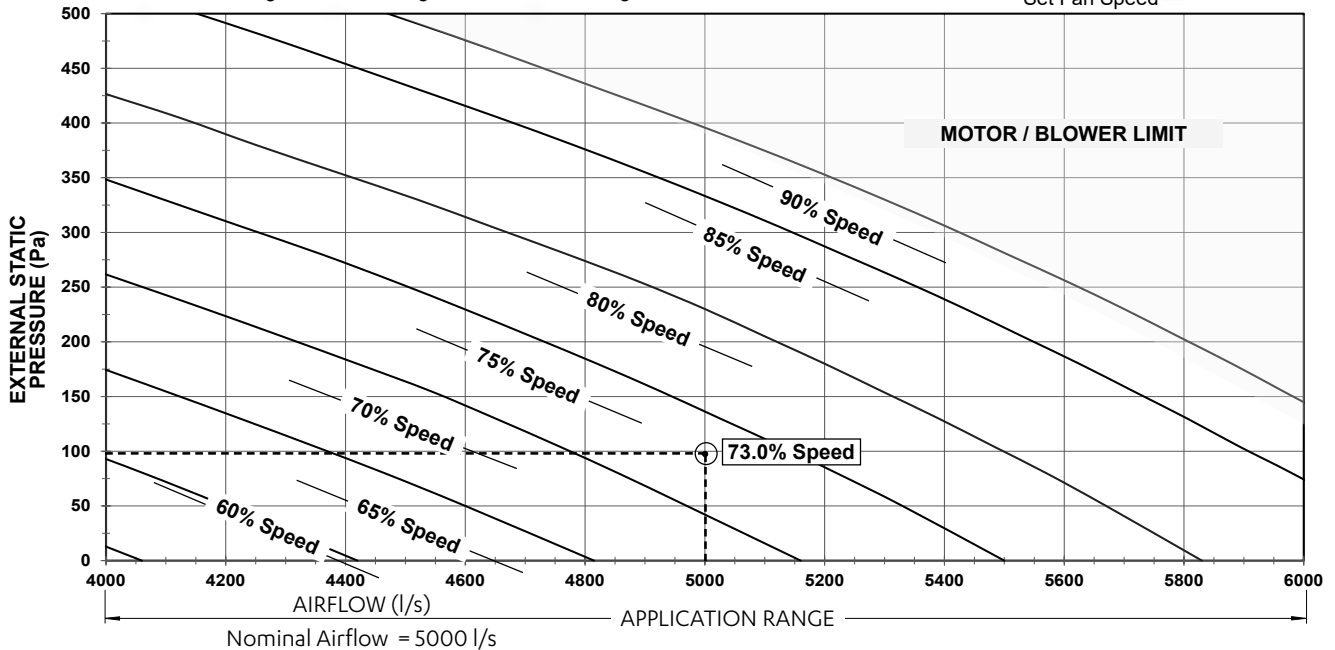

**NOTES**

Fan Performance Data and Fan Curve shown is at dry coil and with no air filters installed. Consider ext. static pressure drop specific to your design requirements.

## 24. REFRIGERANT CHARGING

### NOTES

- The units detailed on this guide are pre-charged with R-410A refrigerant. Should there be need to add or remove some refrigerant, it is recommended to follow one of the charging methods explained below.
- The use of other material as a refrigerant other than R-410A may cause explosion and/or personal injury.
- Where crankcase heaters are in operation, ensure to power up the unit for a minimum of 3 hours prior to starting the compressor. For colder climates, a longer time period may be required.
- Never allow R-410A refrigerant to vent into the atmosphere. This is a serious offence in Australia and New Zealand. Always reclaim refrigerant using equipment and container dedicated for R-410A system use only.
- All work must be carried out in accordance with Australia and New Zealand refrigerant handling code of practice.
- Only qualified technicians must perform any work related to addition or removal of refrigerant.
- R-410A refrigerant must always be charged in liquid state. Always charge refrigerant in the unit liquid line. The air conditioning system should always be liquid charged from the cylinder. When the system is in a vacuum, always charge into the high pressure side. Although it is acceptable to charge refrigerant into the discharge service port, but the liquid line service port on the schrader valve is recommended.
- When the system is operating in cooling mode, it can be charge through the service port on the suction line ball valve (larger of the two schrader valves). This ensures the liquid refrigerant goes into the accumulator and then slowly enters the compressor.

### CAUTION

R-410A refrigerant has POE oil that rapidly absorbs moisture. The maximum time any system can be opened to atmosphere is 15 minutes.

### NOTE FOR SUBCOOL AND SUPERHEAT ADJUSTMENT

This unit is designed with INTERLACED INDOOR HEAT EXCHANGER. Ensure that ALL compressors are running in order to optimise the performance of the unit before reading discharge pressure and liquid line temperature. Then make the necessary refrigerant charge or Thermal Expansion Valve (TXV) adjustment when required. If only ONE or TWO compressors are running, the subcool and superheat results will be different when compared with THREE compressors running.

REFRIGERANT CHARGE DETAILS			
MODEL		PKY820T	PKY960T
Refrigerant Type		R-410A	R-410A
Refrigerant - Circuit #1	grams	8300	11000
Refrigerant - Circuit #2	grams	8300	11000
Refrigerant - Circuit #3	grams	8300	11000

### 24.01. Charging Method 1: Subcooling and Superheat

#### Parameters:

**LLT** = Liquid Line Temperature

**SCT** = Saturated Condensing Temperature

**SLT** = Suction Line Temperature

**SST** = Saturated Suction Temperature

#### Cooling Operation:

Subcooling should be between 4K and 8K.

Superheat should be between 2K and 8K.

#### Heating Operation:

Subcooling should be between 8K and 14K.

Superheat should be between 2K and 8K.

## 24.01.01. Cooling and Heating Operation:

Adjust the refrigerant charge to obtain the correct super heat and subcool for optimal performance as follows:

1. Ensure that air filters are fitted to indoor unit and total system airflows are balanced. (Air filters are not supplied with the unit, it is the responsibility of the installing contractor to provide and fit adequate return air and fresh air filters).
2. Connect service gauges to the Schrader valves. Two sets of service gauges are required, each one connected to circuit 1, 2 and 3, in order to conduct simultaneous refrigerant charge adjustments.

See Diagram Below:

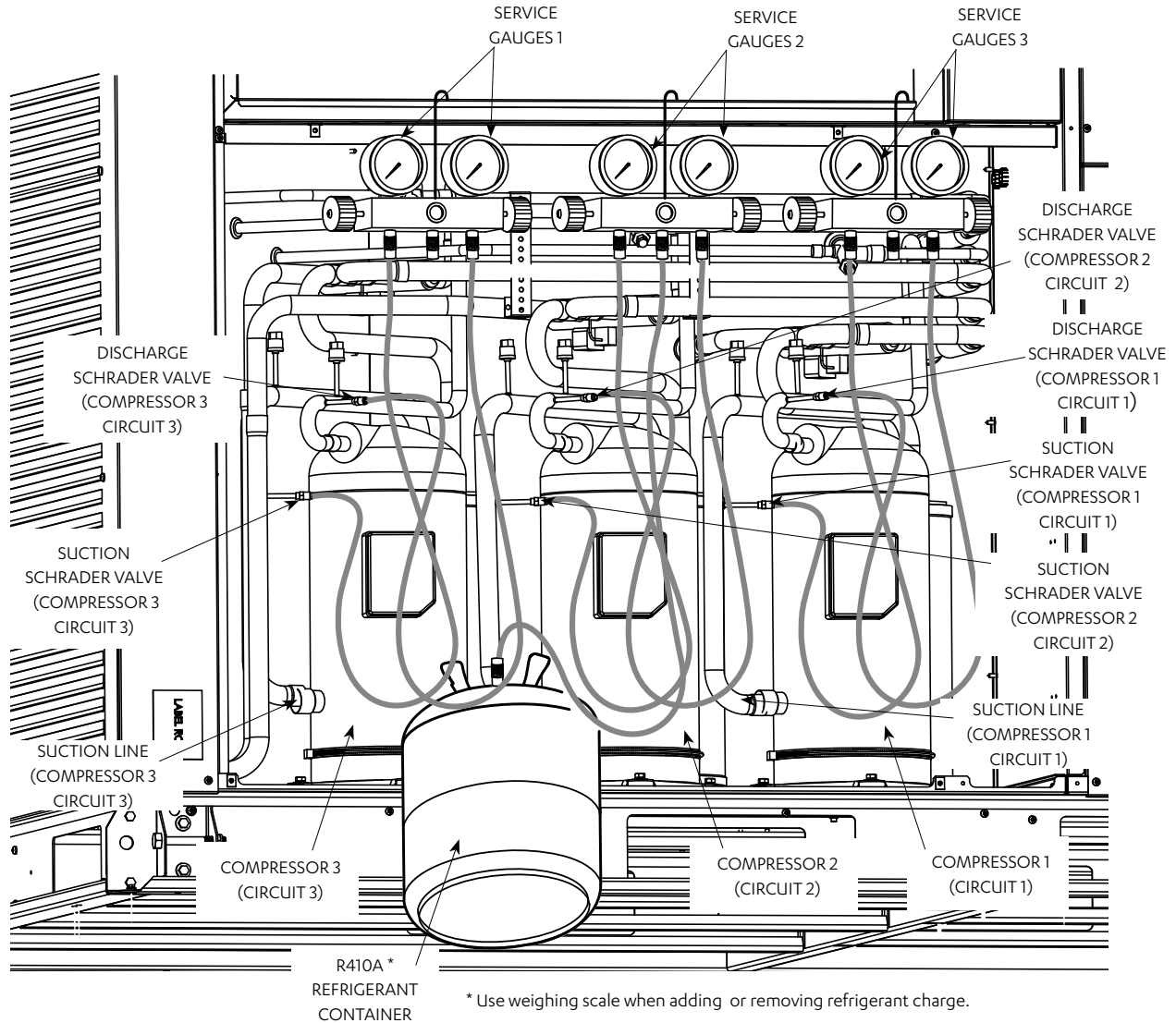

### NOTE

Compressors 2 and 3 will always turn ON/OFF simultaneously with approx. 10 sec. delay on start-up to limit starting currents.



- Mount the temperature sensing devices (one for each circuit) as close as possible to TXV liquid line. Diagram below shows approximate location of temperature sensing devices during Cooling / Heating cycle:

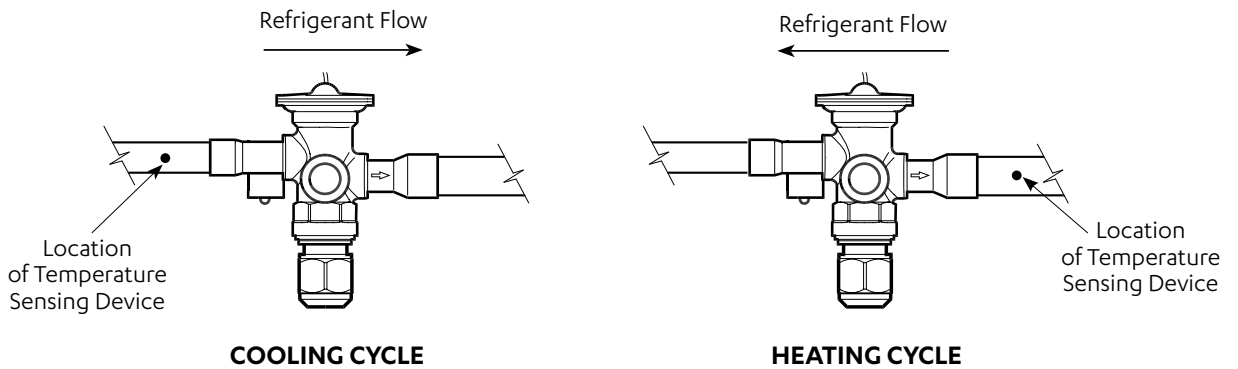

- Start the unit in cool mode ensuring that all refrigeration circuit compressors are in 100% operation before taking service gauges reading. Allow the system to stabilize for next 20 minutes before recording.

Record the discharge pressure, suction pressure, liquid line temperature and suction line temperature for all of the refrigeration circuits:

Circuit 1 System (1st Compressor)

Discharge Pressure = \_\_\_\_\_ kPa

Suction Pressure = \_\_\_\_\_ kPa

Liquid Line Temperature (**LLT**) = \_\_\_\_\_ °C

Suction Line Temperature (**SLT**) = \_\_\_\_\_ °C

Circuit 2 System (2nd Compressor)

Discharge Pressure = \_\_\_\_\_ kPa

Suction Pressure = \_\_\_\_\_ kPa

Liquid Line Temperature (**LLT**) = \_\_\_\_\_ °C

Suction Line Temperature (**SLT**) = \_\_\_\_\_ °C

Circuit 1 System (3rd Compressor)

Discharge Pressure = \_\_\_\_\_ kPa

Suction Pressure = \_\_\_\_\_ kPa

Liquid Line Temperature (**LLT**) = \_\_\_\_\_ °C

Suction Line Temperature (**SLT**) = \_\_\_\_\_ °C

## NOTES

Accurate pressure and temperature measuring tools should be used to achieve satisfactory results. The sensors of thermocouple must be in good contact with the area being measured and must be insulated in order to obtain correct reading.

### 24.01.02. Checking For Subcooling

- From the R-410A Pressure / Temperature Chart record the corresponding Saturated Condensing Temperature (**SCT**) at the given discharge pressure.
- Calculate the system subcooling using the formula below:

$$\text{Subcooling} = \text{SCT} - \text{LLT}$$

- If subcooling is within the range 4-8K, there is no need to add/remove refrigerant.
  - If subcooling is lower than 4K, the system is undercharged, it is necessary to add refrigerant.
  - If subcooling is higher than 8K, the system is over charged. It is necessary to remove refrigerant.

Allow the systems to stabilise and repeat the step 1-3 until subcooling falls within 4-8K.

**24.01.03. Checking for Superheat:**

Maintaining the correct superheat is important for ensuring the evaporator is achieving maximum capacity and avoiding excessive liquid refrigerant returning to the compressor.

1. From the R-410A Pressure/Temperature Chart record the corresponding Saturated Suction Temperature (**SST**) at the given suction pressure.
2. Calculate the system superheat using the formula below:

$$\text{Superheat} = \text{SLT} - \text{SST}$$

3. If superheat is within the range 2-8K, there is no need to add/remove refrigerant.
  - If superheat is lower than 2K, it means that liquid refrigerant may be returning to compressor. It is necessary to remove refrigerant or check TXV settings.
  - If superheat is higher than 8K, it means that refrigeration capability of evaporator is not fully maximised. It is necessary to add refrigerant charge or check TXV settings.

Allow the systems to stabilise and repeat the step 1-3 until superheat falls within 2-8K.

**NOTE**

The above recommendations are based on design conditions of 35°C DB (outdoor), air entering indoor at 27°C DB / 19°C WB (as per AS/NZS 3823.1.2).

**R-410A PRESSURE / TEMPERATURE CHART**

Temp °C	Pressure KPa	Temp °C	Pressure KPa	Temp °C	Pressure KPa	Temp °C	Pressure KPa
-60	-34.4	-28	194.9	4	805.9	36	2090.7
-59	-30.7	-27	206.9	5	834.1	37	2145.5
-58	-26.8	-26	219.2	6	862.9	38	2201.3
-57	-22.8	-25	231.9	7	892.6	39	2258.2
-56	-18.6	-24	245.1	8	922.8	40	2316.1
-55	-14.2	-23	258.7	9	953.8	41	2375.1
-54	-9.6	-22	272.6	10	985.4	42	2435.1
-53	-4.8	-21	286.9	11	1017.8	43	2496.2
-52	0.8	-20	301.7	12	1050.9	44	2558.5
-51	5.3	-19	316.9	13	1084.7	45	2621.8
-50	10.7	-18	332.6	14	1119.2	46	2686.2
-49	16.3	-17	348.7	15	1154.6	47	2751.8
-48	22.2	-16	365.2	16	1190.7	48	2818.5
-47	28.2	-15	382.3	17	1227.5	49	2886.4
-46	34.0	-14	399.7	18	1265.2	50	2955.5
-45	40.9	-13	417.7	19	1303.6	51	3025.7
-44	47.8	-12	436.2	20	1342.9	52	3097.2
-43	54.8	-11	455.1	21	1382.9	53	3169.9
-42	62.1	-10	474.6	22	1423.9	54	3243.7
-41	69.6	-9	494.6	23	1465.7	55	3318.9
-40	77.4	-8	515.1	24	1508.3	56	3395.2
-39	85.5	-7	536.2	25	1551.8	57	3472.9
-38	93.9	-6	557.8	26	1596.2	58	3551.8
-37	102.5	-5	579.9	27	1641.4	59	3631.9
-36	111.5	-4	602.6	28	1687.6	60	3713.5
-35	120.8	-3	625.9	29	1734.6	61	3796.3
-34	130.4	-2	649.8	30	1782.6	62	3880.5
-33	140.3	-1	674.3	31	1831.6	63	3965.9
-32	150.5	0	699.4	32	1881.5	64	4052.8
-31	161.1	1	724.9	33	1932.3	65	4140.9
-30	171.9	2	751.3	34	1984.1	66	4230.6
-29	183.3	3	778.3	35	2036.9	67	4321.5

**24.02. Charging Method 2: Cooling Charging Curve**

1. Start and run the unit in cool mode, ensuring that all refrigeration circuit compressors are in 100% operation and systems stabilized for 20 minutes, record discharge pressure and liquid line temperature.
2. Plot the data in the cooling charging curve below.
3. If the plotted data point falls above the charging curve, it is necessary to remove refrigerant.
4. If the plotted data point falls below the charging curve, it is necessary to add refrigerant.
5. Repeat process 1 - 4 until the plotted data point falls along the curve.

**NOTE**

- Accurate pressure and temperature measuring tools should be used to achieve satisfactory results. The sensors of thermocouple must be in good contact with the area being measured and must be insulated in order to obtain correct reading.

**EXAMPLE:**

Discharge Pressure = 3350 kPa

Liquid Line = 45°C

Action: Remove refrigerant charge from the system.

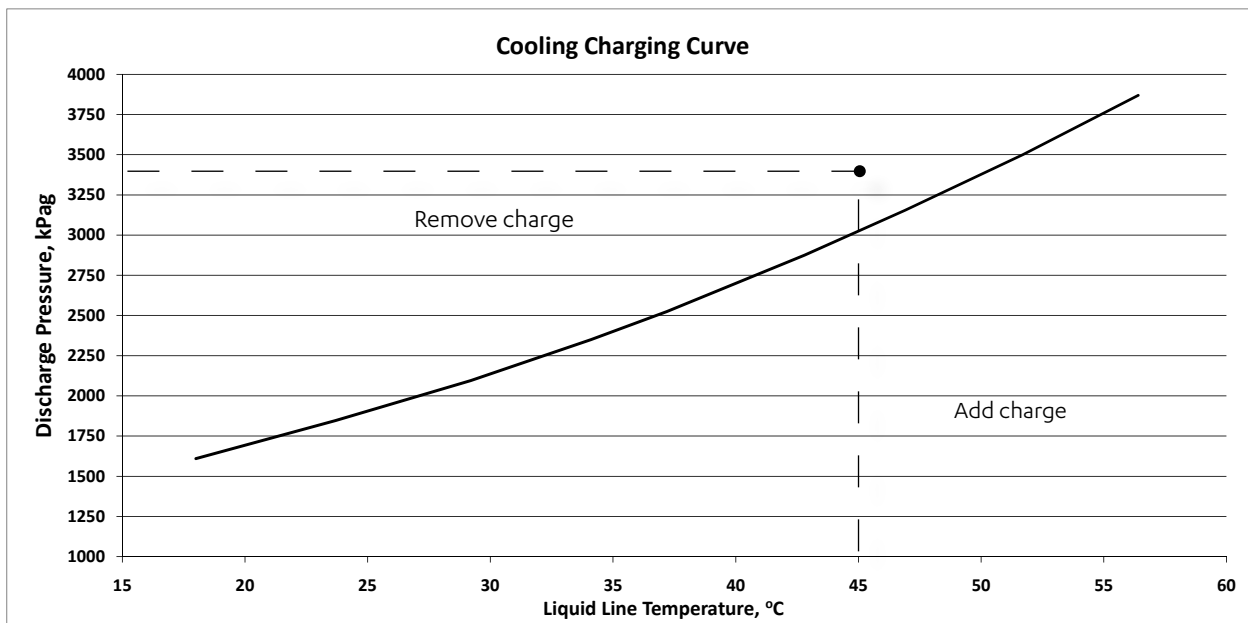

24.03. Thermal Expansion Valve (TXV) Adjustment

**⚠ CAUTION**

- Allow the systems to stabilise for 20 minutes before adjusting the thermal expansion valve (TXV) in order to ensure correct subcooling and superheat conditions. Turn Superheat Adjustment spindle 1/4 turn at a time, stabilising the systems in between adjustment, check condition, adjust again if necessary until correct subcool and superheat conditions are attained.
- Thermal Expansion Valves are provided:  
3 x TXV for each compressor

**Subcool Adjustment**

(Refer Subcool Adjustment to Refrigerant Charging Section).

**Superheat Adjustment**

If superheat is lower than 2k = turn Adjustment Spindle  $\frac{1}{4}^+$ , stabilise system for 20 minutes, adjust if required.

If superheat is higher than 8k = turn Adjustment Spindle  $\frac{1}{4}^-$ , stabilise system for 20 minutes, adjust if required.

See Diagram Below

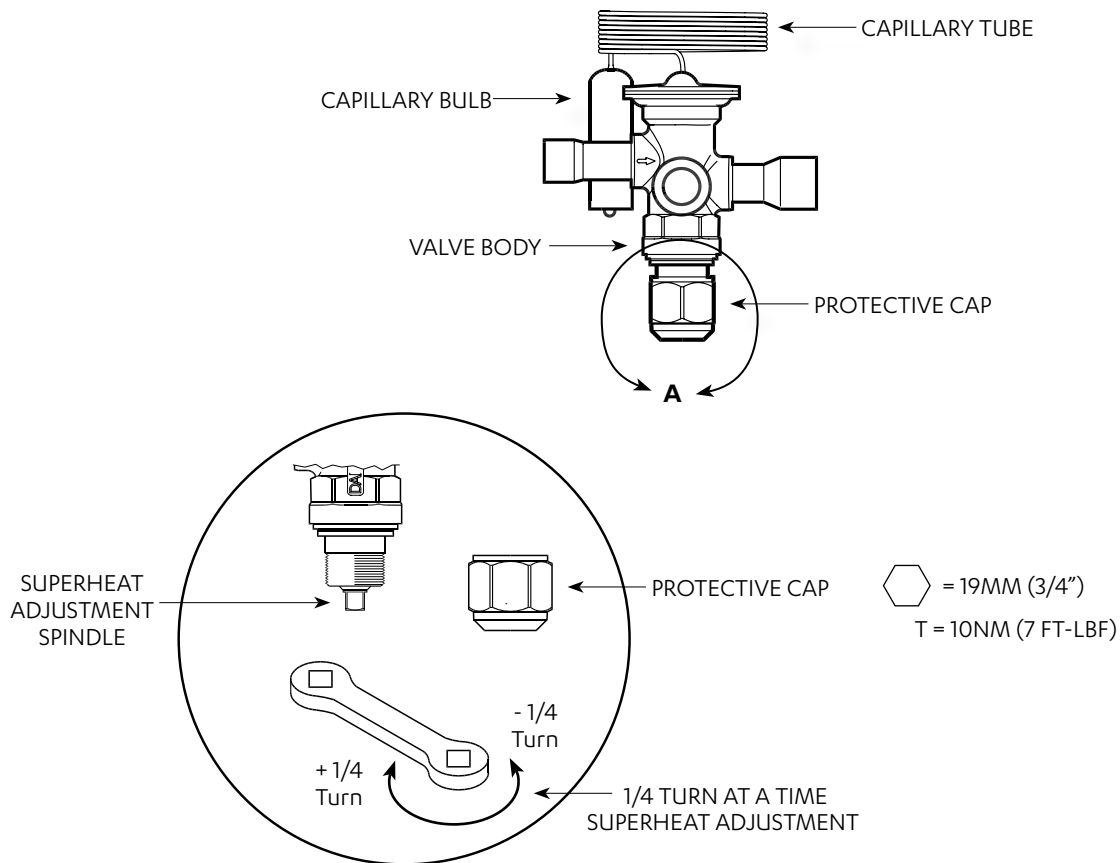

**DETAIL A**

## 25. FAULT DISPLAY CODES

### 25.01. Control Fault Code Displays

Description	Display Code	Type	Alarm Condition	Reset Condition
Out coil temp 1 faulty or wiring open/ short circuit (input U6)	AL08	Alarm	Outdoor Temperature 1 out of Range	Normal Operating Temperature
Out coil temp 2 faulty or wiring open/ short circuit (input U6)	AL10	Alarm	Outdoor Temperature 2 out of Range	Normal Operating Temperature
Room Air temp faulty or wiring open/ short circuit (input U9)	AL11	Alarm	Room Temperature Sensor faulty	Normal Operating Temperature
Outside Air temp faulty or wiring open/ short circuit (input U10)	AL12	Alarm	Outside Air Temperature Sensor faulty	Normal Operating Temperature
Compressor 1 Low Pressure Fault	AL15	Alarm	Ps < 165kPa	Ps > 330kPa
Compressor 2 Low Pressure Fault	AL16	Alarm	Ps < 165kPa	Ps > 330kPa
Compressor 1 High Pressure Fault	AL19	Alarm	Pd > 4500kPa	Pd < 3506kPa
Compressor 2 High Pressure Fault	AL20	Alarm	Pd > 4500kPa	Pd < 3506kPa
Compressor 1 High temperature Alarm	AL42	Alarm	Compressor 1 discharge high fault Discharge Temp > 120°C	Discharge Temp < 100°C
Compressor 2 High temperature Alarm	AL43	Alarm	Compressor 1 discharge high fault Discharge Temp > 120°C	Discharge Temp < 100°C
CO <sub>2</sub> Sensor Fault	AL48	Alarm	CO <sub>2</sub> sensor reading out of range	Normal operating CO <sub>2</sub> reading
Indoor Fan Anti -freeze Action	AL59	Warning	Temperature out of Range	Normal Operating Temperature
Service Reminder Please Clean the Indoor Fan air filter	AL200	Warning	Air Filter Timer Timed-Out Filter warning	Clean/Replace Filter and Reset Timer

### 25.02. Soft Starter Display Codes

Operation Mode	On-Board LED Indication
At first power Up	One per second for 10 seconds
Ready to Start	LED Off
Compressor Running	LED remains Off
Delay After Compressor Stop	One Blink per second for 50 secs, then LED Off

Fault Operation	On-Board LED Indication
Phase L1 Missing	LED Off (No Lights and No Compressor Operation)
Compressor Winding Open	4 Blinks (in burst) for 50 secs, then Compressor tries to start again.
Incorrect Phase Rotation	3 Blinks (in burst), Compressor will not try to start
Phase Lost or Low Voltage (less 200 V)	3 Blinks (in burst), Compressor will not try to start
Compressor Winding Swapped	LED Off (Compressor runs noisy - clacking sound)
Compressor Failed to Start	2 Blinks for 4 minutes

**NOTE**

As soon as the error condition goes away, the board logic will remove the error code.

## 26. TROUBLESHOOTING GUIDE

Alarm Code	Description	Check Points
AL19 AL20	Compressor HP Fault	Check the Outdoor Fan operation.
		Check the coils are clean.
		Check for excess refrigerant charge.
		Check for non-condensable. (Standing pressure with reference to Press. Temp. Chart)
		Check the HP switch for continuity. (There is no continuity in FAULT condition)
AL15 AL16	Compressor LP Fault	Check for less refrigerant charge.
		Check for non-condensable. (Standing pressure with reference to Press. Temp. Chart)
		Check the LP switch for continuity. (There is no continuity in FAULT condition)
AL08	Outdoor Coil Temp 1 Fault	Check the wiring and the resistance through the sensor probe.
AL10	Outdoor Coil Temp 2 Fault	Check the wiring and the resistance through the sensor probe.
AL11	Room Air Temp Sensor Fault	Check the wiring and the resistance through the sensor probe.
AL12	Outdoor Air Temp Sensor Fault	Check the wiring and the resistance through the sensor probe.
AL51	Indoor Coil Sensor Fault	Check the wiring and the resistance through the sensor probe.
AL200	Filter Alarm	Check the filter if dirty. Clean or replace if required.

## 27. MAINTENANCE

This section describes the procedure that must be performed as a part of normal maintenance program. Regular servicing of equipment by licensed technician is highly recommended. Regular servicing of your unit helps in maintaining its optimum performance and reliability. **The checklist and service periods provided on this manual are guides only, as some sites may require more frequent servicing.**

Always disconnect electrical power to the unit before performing maintenance. It is always a safe practice to observe all safety warnings and cautions when conducting maintenance tasks.

### DANGER

#### **Live Electrical Connections !**

It may be necessary to work with live electrical components on certain maintenance tasks. Only qualified technicians who are competently trained are allowed to perform these tasks.

### WARNING

#### **Hazardous Voltage !**

Always make sure that all power supply, including remote controls, are disconnected before performing maintenance. Beware of EC Motors with high power capacitors and which can have dangerous voltages at terminals for up to 5 min after main power has been isolated. Wait at least 5 min after power isolation and test for high voltage before performing service work. Observe proper Lock-Out/Tag-Out procedures to ensure that power cannot be inadvertently energised. Failure to disconnect power before maintenance procedures can result in serious injury or death.

#### **Periodic Maintenance Checkpoint**

- Perform all monthly maintenance inspections.
- Inspect coil surfaces for cleanliness. Clean as required, apply cleaning procedures based on prevailing industry standard.
- Inspect unit air filters, clean or replace as required.

#### **Annual Maintenance Checklists**

- Perform general maintenance inspections.
- Perform scheduled start-up checks.
- Leak test refrigerant circuits.
- Inspect contacts of all contactors and relays. Replace all worn contacts as required.
- Inspect, clean and tighten all electrical connections.
- Check fans for balanced operation. Make sure that there are no loose screws / bolts, no fan blades interference and no damage to the fans and guards.
- Inspect the air filters, clean or replace as required.
- Clean and repaint any corroded panel section.
- Ensure no blockage of airflow through variable speed drive and drive fan is operating correctly.



### Cleaning the Condenser Coils

Clean the coils at least once a year or more frequently if unit is located in a dusty and/or dirty environment, in order to maintain your system's proper operating performance. High discharge pressures are good indication that the coils need cleaning. When using detergent or solvents to clean the coils, follow the manufacturer's instructions to avoid potential damage to the coils and to the unit.

To clean the refrigerant coils, use a soft brush and water spray, such as garden hose or pressure washer with low pressure nozzle.

#### DANGER

##### **Beware of Rotating Fan Blades !**

- Always make sure that all power supply, to the Outdoor Fans are turn-off and isolated.
- Observe WH&S safety procedures, do not wear loose clothing and any jewelry when working near the fans.
- Wear PPE whenever performing any maintenance procedures.
- Observe all necessary procedures when working on a confined space.

#### WARNING

##### **Be Careful Not to Spray Water into the Electrical Components !**

#### CAUTION

##### **Do Not Use High Alkaline Detergent !**

When using detergent for coil cleaning, ensure that the alkaline level is no higher than 8.5, which cause corrosion damage to the coils.

### Coil Cleaning Procedures

- Disconnect power to the unit.
- Remove the louvered panels from the unit to gain access to the air inlet side of the coils.
- Use a soft brush to remove loose dirt and debris from both sides of the coils.
- Straighten bent coil fins with fin comb.
- Prepare the detergent solutions according to the manufacturer's instructions.
- Spray solution at a 90° angle to the coils, keeping a minimum nozzle spray angle of 15°, with at least a 1800mm distance from the coils and 600 psi pressure.
- Spray leaving air side of the coils first then the air inlet side. Allow the solution to stand on the coils for five minutes.
- Rinse both sides of the coils with cool clean water.
- Inspect the coils, if they are still dirty, repeat the cleaning procedure.
- Clean and wipe dry the outer and inner sides of the unit, the refrigerating parts and other components.
- Ensure that the condensate drain lines are not clogged.
- Reinstall all unit panels, covers and guards.
- Restore electrical power to the unit.

## 28. MAINTENANCE FREQUENCY CHECKLIST

ELECTRICAL											
Parts	Service Period					Detail of Service Check	Service Methods				
	1 Mth	3 Mth	6 Mth	1 Yr	2 Yrs			3 Yrs	4 Yrs	5 Yrs	
Isolators/Printed Circuit Boards			✓							Visual Inspection	Tighten Terminals as necessary on isolators and printed circuit boards
Electrical Connections			✓							Check all electrical terminals, mains, communications, etc.	Re-tighten if loose.
Magnetic Contactor			✓							Check for loose terminal connections.	Tighten electrical terminals. Remove any dust.

### INDOOR SECTION

Parts	Service Period					Detail of Service Check	Service Methods				
	1 Mth	3 Mth	6 Mth	1 Yr	2 Yrs			3 Yrs	4 Yrs	5 Yrs	
Casing/Panels and Frames		✓								Visual check for damage, rust and dust accumulation.	For highly corrosive environment, wash panels quarterly with water and neutral detergent solution. Wax panels. Repair/re-paint where required.
Insulation					✓					Visual check for insulation conditions.	Repair/replace insulation material.
Fan			✓							Visual check for run out of balance and dust attached	Clean off dust as necessary to negate possibility of fan running out of balance
Motor				✓ Ω						Visual check on wiring. Insulation resistance check to be carried out annually	Measure insulation resistance. Should be more than 1MΩ.
Heat Exchanger			✓							Check for clogging by dust. Check for leaks/damage.	Clean air inlet side as necessary. Straighten any bent fins using fins comb.
Drain Pan/ Condensation line		✓								Check for obstructions and free flow of water	Clean to eliminate obstructions/ sludge and check condition of pan. Pour water to ensure flow
Filter*	✓									Check for clogging by dust.	Clean Filter
Temperature Readings		✓								Measure air on and air off	Place temperature probe in return and supply air of the unit.
Damper Motors (If fitted)			✓							Visual inspection of motors open/closing. Ensure no obstructions	Drive motors opened and closed. Ensure correct operation

\*Service period for filter cleaning may vary depending on operating time and surrounding environment.

OUTDOOR SECTION											
Parts	Service Period									Detail of Service Check	Service Methods
	1 Mth	3 Mth	6 Mth	1 Yr	2 Yrs	3 Yrs	4 Yrs	5 Yrs			
Casing/Panels and Frames		✓								Visual check for damage, rust and dust accumulation.	For highly corrosive environment, wash panels quarterly with water and neutral detergent solution. Wax panels. Repair/re-paint where required.
Insulation					✓					Visual check for insulation conditions.	Repair/replace insulation material.
Fan			✓							Visual check for run out of balance and dust attached.	Clean off dust as necessary to negate possibility of fan running out of balance.
Motor				✓ Ω						Visual check on wiring. Insulation resistance check to be carried out annually.	Measure insulation resistance. Should be more than 1MΩ.
Heat Exchanger			✓							Check for clogging by dust. Check for leaks/damage.	Clean air inlet side as necessary. Straighten any bent fins using fins comb.
Condensate Drain Line		✓								Check for obstructions and free flow of water.	Clean to eliminate obstructions/sludge and check condition of drain line. Pour water to ensure flow.
Compressor		✓ Ω								Check for high/low pressure. Measure insulation resistance. Check compressor for abnormal noise/vibrations.	Measure insulation resistance. Should be more than 1MΩ.
Refrigeration Operational Readings		✓								Make note of operational reading in test cool/heat.	Check operating pressures, record super heat and sub-cool values.
Safety Devices			✓							Check calibration of safety devices such as HP and LP controls, sensors, etc.	Check resistance of sensors, pressure cut in/cut out of pressure controls.
Faults		✓								Check for any previous fault history on the unit.	Investigate any causes for previous faults, reset fault history.

## 29. SENSORS DETAIL

<b>TEMPERATURE SENSORS</b>			
<b>Description</b>	<b>Location</b>	<b>Type</b>	<b>ActronAir Part Number</b>
Compressor 1 Discharge Temp. Sensor	Compressor 1 Discharge line	100kΩ NTC	2060-018
Compressor 2 Discharge Temp. Sensor	Compressor 2 Discharge line	100kΩ NTC	2060-018
Outdoor Coil 1 Temperature Sensor	Last return bend of Coil system 1	10kΩ NTC	2060-006
Outdoor Coil 2 Temperature Sensor	Last Return Bend of Coil system 2	10kΩ NTC	2060-026
Room Air Temperature Sensor	Packed together with Installation and Commissioning Guide	10kΩ NTC	2060-037
Ambient Air Temperature Sensor	Outdoor Coil System 2 Air Inlet side	10kΩ NTC	2060-036
Indoor Coil Temperature Sensor	Indoor Coil - Model dependent	10kΩ NTC	2060-016

<b>SWITCHES</b>			
<b>Description</b>	<b>Location</b>	<b>Type</b>	<b>ActronAir Part Number</b>
Compressor 1 High Pressure Switch	Compressor 1 Discharge Line	Pressure Switch	2060-019
Compressor 2 High Pressure Switch	Compressor 2 Discharge Line	Pressure Switch	2060-019
Compressor 1 Low Pressure Switch	Compressor 1 Suction Line	Pressure Switch	2060-020
Compressor 2 Low Pressure Switch	Compressor 2 Suction Line	Pressure Switch	2060-020

**30. KEY PARTS LIST**

Item	Description	Part Number	PKY820T	PKY960T
			Qty	Qty
1	Compressor #1	1560-437	1	-
	Compressor #1	1560-438	-	1
2	Compressor #2	1560-437	1	-
	Compressor #2	1560-438	-	1
3	Compressor #3	1560-437	1	-
	Compressor #3	1560-438	-	1
4	Outdoor Fan	2505-136	3	3
5	EC ID Fan - Spider Mount	2590-014	2	2
6	Outdoor Board CM100	2020-136	1	1
7	Control Interface CP05	2090-023	1	1
8	Thermostatic Expansion Valve #1 TGEL 9	4570-126	1	1
9	Thermostatic Expansion Valve #2 TGEL 9	4570-126	1	1
10	Thermostatic Expansion Valve #3 TGEL 9	4570-126	1	1

### 31. START-UP AND COMMISSIONING REPORT

**Completing Settings Log Procedures**

1. Switch-Off all motor start circuit breakers (MSCB), leaving circuit breakers CB1, CB2 and CB3 Switched-On.
2. Fill-in all current settings and information in SETTINGS LOG below:

**Settings Log:**

**NOTE**

Please log all required information below, before any software changes are to be made. Failure to do so will cause difficulties in restarting the unit operation back to original settings. Leave this manual in a secure location near the unit.

**INSTALLATION INFORMATION**

CUSTOMER	Name:		Tel. No.	
	Address:			
INSTALLER	Name:		Tel. No.	
	Address:			
SITE ADDRESS:			Date:	

**MODE OF OPERATION**

Mode	<input type="checkbox"/> Auto	<input type="checkbox"/> Cool Only	<input type="checkbox"/> Heat Only
Indoor Fan Mode	<input type="checkbox"/> Continuous	<input type="checkbox"/> Auto Cycle	
Return Air Temperature Setpoint	°C		
Temp. Setback	°C	<input type="checkbox"/> Enabled	<input type="checkbox"/> Disabled
Enable Scheduler	<input type="checkbox"/> Yes	<input type="checkbox"/> No	
Daylight Saving Time Set	<input type="checkbox"/> Yes	<input type="checkbox"/> No	
Transition Time	min.	Start	in at

**INDOOR FAN SETTINGS**

% ID Fan Speed		%
After Hours Operation Duration		H
End	in at	

**TIMECLOCK SETTINGS**

	Event 1		Event 2	
Monday	_____	to _____	_____	to _____
Tuesday	_____	to _____	_____	to _____
Wednesday	_____	to _____	_____	to _____
Thursday	_____	to _____	_____	to _____
Friday	_____	to _____	_____	to _____
Saturday	_____	to _____	_____	to _____
Sunday	_____	to _____	_____	to _____

**SPECIAL DAYS SETTINGS**

	Day / Month	Event 1	Event 2		Day / Month	Event 1	Event 2
Day 1	_____	_____	_____	Day 7	_____	_____	_____
Day 2	_____	_____	_____	Day 8	_____	_____	_____
Day 3	_____	_____	_____	Day 8	_____	_____	_____
Day 4	_____	_____	_____	Day 10	_____	_____	_____
Day 5	_____	_____	_____	Day 11	_____	_____	_____
Day 6	_____	_____	_____	Day 12	_____	_____	_____

**SYSTEM CONFIGURATIONS (To access this menu, please enter the Service password: 7378).**

**G. Service → e. Communicate config.**

Ge1	Address:	Protocol:	Speed:
Ge2	Enable BMS to turn the unit On/Off	<input type="checkbox"/> Yes	<input type="checkbox"/> No
	On loss of communication	turn off / turn on / use timeclock	
Ge3	Enable Din4 to turn the unit On/Off	<input type="checkbox"/> Yes	<input type="checkbox"/> No

**G. Service → f. Service settings → a. Working hour set**

Gfa1	Indoor Filter:	_____	hours
	Filter Fault relay:	<input type="checkbox"/> Yes	<input type="checkbox"/> No
	Indoor Fan:	_____	hours
	Compressor:	_____	hours

**G. Service → f. Service settings → b. Probe adjustment**

(Return Air Temperature) Room Temp cal :	_____	°C
--	-------	----

**G. Service → f. Service settings → c. Thermoregulation**

Gfc1

Room Temperature Setpoint:	_____	°C
Dead band:	_____	°C
Cool Proportion band:	_____	°C
Heat Proportion band:	_____	°C
Integral Time:	_____	second

**G. Service → f. Service settings → c. Thermoregulation**

Gfc8

Multi Input 1		<input type="checkbox"/> Yes	<input type="checkbox"/> No
SUPPLY AIR TEMP	<input type="checkbox"/>	Probe Type	
ECONOMY ENABLE	<input type="checkbox"/>	NTC	<input type="checkbox"/>
NIGHT MODE ENABLE	<input type="checkbox"/>	0-5V	<input type="checkbox"/>
0-10V STAGE CONT	<input type="checkbox"/>	ON/OFF	<input type="checkbox"/>
0-10V IN FAN SPD	<input type="checkbox"/>	4-20mA	<input type="checkbox"/>
VIEW ONLY INPUT	<input type="checkbox"/>	0-20mA	<input type="checkbox"/>
CO <sub>2</sub> SENSOR	<input type="checkbox"/>	0-10V	<input type="checkbox"/>
PHASE FAIL RELAY	<input type="checkbox"/>		
Multi Input 2		<input type="checkbox"/> Yes	<input type="checkbox"/> No
SUPPLY AIR TEMP	<input type="checkbox"/>	Probe Type	
ECONOMY ENABLE	<input type="checkbox"/>	NTC	<input type="checkbox"/>
NIGHT MODE ENABLE	<input type="checkbox"/>	0-5V	<input type="checkbox"/>
0-10V STAGE CONT	<input type="checkbox"/>	ON/OFF	<input type="checkbox"/>
0-10V IN FAN SPD	<input type="checkbox"/>	4-20mA	<input type="checkbox"/>
VIEW ONLY INPUT	<input type="checkbox"/>	0-20mA	<input type="checkbox"/>
CO <sub>2</sub> SENSOR	<input type="checkbox"/>	0-10V	<input type="checkbox"/>
PHASE FAIL RELAY	<input type="checkbox"/>		

Gfc2

After Hour	SW & Temp.	<input type="checkbox"/>	SW Only	<input type="checkbox"/>
Room temp. probe weight value				

Gfc4

Supply Fan Min. Speed	_____	%
Supply Fan Med. Speed	_____	%
Supply Fan Max. Speed	_____	%
Supply Fan Min. Temp.	_____	°C
Supply Fan Max. Temp.	_____	°C

Gfc5

Supply Fan Continuous	<input type="checkbox"/> Yes	<input type="checkbox"/> No	
Cycle on de-ice	<input type="checkbox"/> Yes	<input type="checkbox"/> No	
One Speed Fan	<input type="checkbox"/> Yes	<input type="checkbox"/> No	
Speed Fan	<input type="checkbox"/> Low	<input type="checkbox"/> Med	<input type="checkbox"/> High
Supply Fan Run-on	_____	second	
Heat Start Delay	_____	second	

Gfc11

Unit Control Mode:	
Internal Sensors	<input type="checkbox"/>
Remote Terminal	<input type="checkbox"/>
Remote Demand	<input type="checkbox"/>
External Input	<input type="checkbox"/>
Supply Fan Control:	_____
Select Wall Control:	_____

Gfc6

Setpoint Limit Min. by user	_____	°C
Setpoint Limit Max. by user	_____	°C
User Setpoint	_____	
User Mode Sel	_____	
Modelock timer	_____	second

Gfc12

Unit Series:	_____
Unit Model:	_____
Variations:	_____

Gfc7

Enable Night Mode Scheduler	_____
Start Time:	Finish Time: _____

**G. Service → f. Service settings → c. Thermoregulation (Continuous)**

Gfc13	
Type of fans fitted	
Supply:	_____
Outdoor:	_____
Econ. Cycle Fitted:	<input type="checkbox"/> Yes <input type="checkbox"/> No
Econ. Type:	

Gfc15	
Room Temp / Humidity	
Sensor fitted:	<input type="checkbox"/> Yes <sup>(2)</sup> <input type="checkbox"/> No
Use this sensor temp. instead of AI9:	<input type="checkbox"/> Yes <input type="checkbox"/> No

Gfc16	
Outside Temp / Humidity	
Sensor fitted:	<input type="checkbox"/> Yes <sup>(3)</sup> <input type="checkbox"/> No
Use this sensor temp. instead of AI10:	<input type="checkbox"/> Yes <input type="checkbox"/> No

Gfc17	
Alarm Disable	_____
Outdoor Unit	_____
RTN AIR Sensor:	<input type="checkbox"/> Yes <input type="checkbox"/> No

Gfc19	
Damper Scaling	_____ %
Command Start:	_____ %
Command End:	_____ %
Output Start:	_____ %
Output End:	_____ %

Gfc31 <sup>(1)</sup>			
CO <sub>2</sub> Control			
Start:	_____ ppm	End:	_____ ppm
Alarm Output:	<input type="checkbox"/> Enabled <input type="checkbox"/> Disable		
Sensor Fault:	< _____ ppm	> _____ ppm	

<sup>(1)</sup> will be visible when <sup>(4)</sup> is enabled

**SYSTEM CONFIGURATIONS: G. Service → f. Service settings → d. Economy Setting**

Gfd1	
Min Outside Air	
CO <sub>2</sub> Sensor Disabled	Damper Position: _____ %
CO <sub>2</sub> Sensor Disabled	
CO <sub>2</sub> Sensor Enabled <sup>(4)</sup>	_____ ppm _____ ppm
CO <sub>2</sub> Level	_____ % _____ %
Damper Position	

Gfd3	
Economy Cycle	
Outside Air Max Limit	
Temperature:	<input type="checkbox"/> Yes <input type="checkbox"/> No °C
<sup>(5)</sup> Humidity:	<input type="checkbox"/> Yes <input type="checkbox"/> No %
<sup>(5)</sup> Enthalpy:	<input type="checkbox"/> Yes <input type="checkbox"/> No kJ/kg
<sup>(5)</sup> Moisture:	<input type="checkbox"/> Yes <input type="checkbox"/> No g/kg
<sup>(5)</sup> Dew Point:	<input type="checkbox"/> Yes <input type="checkbox"/> No °C

Gfd2	
Economy Cycle	
Enabled	<input type="checkbox"/> Yes <input type="checkbox"/> No
Temperature Difference:	_____ °C
Outside Air Minimum Limit	<input type="checkbox"/> Yes <input type="checkbox"/> No
Temperature:	_____ °C

Gfd4 <sup>(6)</sup>	
Economy Cycle	
Enthalpy Difference:	<input type="checkbox"/> Yes <input type="checkbox"/> No kJ/kg

<sup>(6)</sup> will be visible when <sup>(2)</sup> and <sup>(3)</sup> are set to Yes

<sup>(5)</sup> will be visible when <sup>(3)</sup> outside temp/humidity sensor is set to Yes



**THIS PAGE IS INTENTIONALLY LEFT BLANK**

**THIS PAGE IS INTENTIONALLY LEFT BLANK**

**THIS PAGE IS INTENTIONALLY LEFT BLANK**



# ActronAir

*That's better. That's Actron.*

actronair.com.au

1300 522 722



©Copyright 2019 Actron Engineering Pty Limited ABN 34 002767240. ®Registered Trade Marks of Actron Engineering Pty Limited. ActronAir is constantly seeking ways to improve the design of it's products, therefore specifications are subject to change without notice.

Document: 0525-070 Ver. 3 Issue Date: 07/2022