

SPLIT DUCTED UNIT

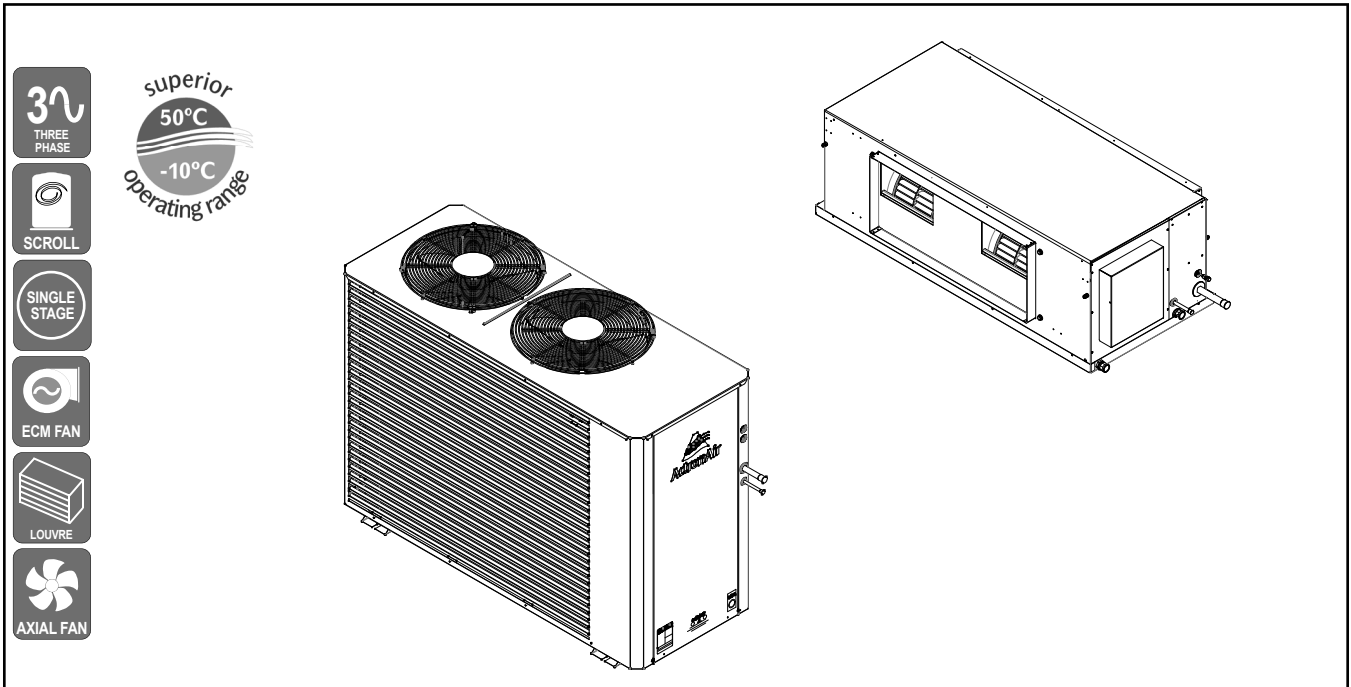

3 Phase
1 Stage
17.56 kW

UNIT FEATURES

- Compliant Scroll Compressor
- EMC High Efficiency Indoor Fan Motor
- Three Speed Outdoor Fan
- Adaptive Demand Defrost
- 20 m Cat5E Cable included
- Low Ambient Cooling Operation to +5 degree
- Fault and Run Indication - Relay Output
- Up to 3 Wall Controllers and 3 Remote Temperature Sensors
- Ready for up to 8 zones
- Hydrophilic Blue Fin Coil Coat Protection - Indoor & Outdoor Coils
- Integral Fan Coil Safety Tray with Drain Kit
- Pre-charged with R-410A Refrigerant
- Powder Coated Outdoor Unit With Louvred Coil Guard

CONTROL OPTIONS AND FEATURES

ActronAir LR7-1/LC7-2

- Available in White or Grey
- 7-day Programmable Controller with 2 Events per Day
- 24-hour ON/OFF Timer
- Temperature Setback
- After Hours Time (LC7 Only)
- Auto, Heat & Cool Modes
- Auto/Continuous Indoor Fan Operation
- Optional 2nd and 3rd Controllers with Mimic Logic
- On-Board Temperature Sensor

ActronAir Neo

- 7" Colour Touch Screen Master Controller
- In-built Wi-Fi and Blue-Tooth
- Neo Connect App
- On-Board Temperature, Humidity and Proximity Sensor
- Optional wireless Zone Sensor
- Available in White or Black

ActronAir Group Control

ActronAir BMS ICUNO-MOD (Modbus 485)

3RD PARTY CONTROL OPTIONS

- Manual Inputs (Heat, Cool and Fan Operation)
- Analogue Input (Fan Only)

PLENUMS (Optional)

- Supply Air Plenums are Available

UNIT OPTIONS

- Three Phase Soft Starter
- Additional Full Coil Coat Protection
- Outdoor Drain Tray
- Horizontal Discharge Condenser
- Vertical Evaporator

SPECIFICATION SUMMARY

OUTDOOR UNIT MODEL	CRA170T	
INDOOR UNIT MODEL	EVA170S	
	(1) TOTAL	(2) NETT
(3) COOLING CAPACITY (kW)	17.56	16.99
(3) SENSIBLE CAPACITY (kW)	14.57	14.00
(4) HEATING CAPACITY (kW)	17.38	17.92
(5) COOLING INPUT POWER (kW)	5.04	
(5) HEATING INPUT POWER (kW)	4.58	
EER	3.48	3.37
COP	3.79	3.91
(6) INDOOR AIRFLOW (l/s) - MIN. / NOMINAL / MAX.	770 / 850 / 900	
(7) OUTDOOR SOUND PRESS. LEVEL @ 3M dB(A) - LOW / MEDIUM / HIGH	50.4 / 51.3 / 53.1	
OUTDOOR SOUND POWER LEVEL dB(A) - LOW / MEDIUM / HIGH	69.8 / 70.7 / 73.1	
POWER SUPPLY - OUTDOOR	400V / 3Ph+N / 50Hz	
POWER SUPPLY - INDOOR	230V / 1Ph+N / 50 Hz	
(8) RATED LOAD AMPS - OUTDOOR / INDOOR / TOTAL	8.7 / 4.1 / 12.8	
(9) FULL LOAD AMPS - OUTDOOR / INDOOR / TOTAL	12.3 / 4.3 / 16.6	
(9) CIRCUIT BREAKER AND CABLE AMPS	20.0	
APPROXIMATE STARTING AMPS	64.5	
WEIGHT (kg) - INDOOR / OUTDOOR	56 / 155	

(1) Total Capacities are based on unit rating excluding indoor fan (kW.)

(2) Measured and tested in accordance with AS/NZS 3823.1.2.

(3) At 27°C DB / 19°C WB entering air temperatures and 35°C ambient.

(4) At 20°C DB entering air temperature and 7°C DB / 6°C WB ambient.

(5) Input power includes indoor fan (kW).

(6) Max. - Min. airflow application range.

(7) Sound levels are determined in an anechoic chamber and may differ once the unit is installed due to ambient conditions.

(8) Full Load Amps are based on compressor and fan motors' maximum expected current.

(9) See Specifications sheet for cable size and circuit breaker size details.

Note: Use input power to estimate running cost.

CAPACITY SELECTION DATA

CRA170T / EVA170S

COOLING PERFORMANCE

AIR ENTERING		TOTAL CAPACITY kW	TOTAL SENSIBLE CAPACITY - kW										
OUTDOOR DB - °C	INDOOR WB - °C		AT DB TEMPERATURE ONTO INDOOR COIL - °C										
			20	21	22	23	24	25	26	27	28	29	30
25	16	18.37	11.15	12.21	13.25	14.29	15.30	16.13					
	17	18.37	10.11	11.13	12.19	13.24	14.28	15.29	16.20				
	18	18.74	9.00	10.08	11.10	12.17	13.22	14.25	15.30	16.25	17.11		
	19	19.21	7.87	8.97	10.07	11.08	12.14	13.19	14.23	15.28	16.25	17.16	17.96
	20	19.65	6.70	7.83	8.94	10.04	11.05	12.10	13.15	14.21	15.24	16.24	17.18
	21	20.21		6.68	7.78	8.91	9.99	11.00	12.08	13.12	14.15	15.21	16.22
22	20.73			6.65	7.74	8.87	9.96	11.04	12.03	13.07	14.13	15.17	
30	16	17.73	10.84	11.89	12.94	13.96	14.92	15.67					
	17	17.70	9.80	10.82	11.89	12.93	13.95	14.94	15.84				
	18	18.03	8.70	9.79	10.79	11.86	12.90	13.93	14.95	15.91	16.65		
	19	18.40	7.57	8.68	9.77	10.78	11.83	12.89	13.92	14.93	15.91	16.79	
	20	18.85	6.43	7.55	8.66	9.74	10.75	11.81	12.86	13.89	14.92	15.92	16.84
	21	19.40		6.39	7.50	8.61	9.71	10.73	11.77	12.83	13.88	14.89	15.89
22	19.88			6.36	7.46	8.58	9.67	10.67	11.73	12.79	13.83	14.85	
35	16	17.04	10.50	11.55	12.59	13.60	14.51						
	17	17.04	9.47	10.49	11.54	12.58	13.59	14.56	15.39				
	18	17.26	8.38	9.45	10.46	11.52	12.56	13.58	14.58	15.51			
	19	17.56	7.25	8.36	9.45	10.44	11.51	12.56	13.58	14.57	15.54	16.11	
	20	18.03	6.11	7.22	8.33	9.42	10.42	11.47	12.52	13.55	14.56	15.55	16.45
	21	18.48		6.09	7.20	8.31	9.38	10.40	11.43	12.49	13.51	14.54	15.54
22	18.93			6.06	7.16	8.26	9.36	10.35	11.40	12.44	13.49	14.52	
40	16	16.20	10.10	11.17	12.18	13.16	13.97						
	17	16.22	9.04	10.10	11.15	12.17	13.19	14.09					
	18	16.33	8.01	9.09	10.08	11.14	12.18	13.17	14.13	14.94			
	19	16.59	6.88	7.99	9.15	10.06	11.11	12.17	13.16	14.16	15.05		
	20	16.98	5.76	6.88	7.97	9.04	10.04	11.09	12.13	13.15	14.14	15.09	15.88
	21	17.40		5.74	6.84	7.94	9.02	10.02	11.05	12.10	13.13	14.12	15.10
22	17.84			5.70	6.81	7.90	8.99	9.99	11.01	12.06	13.09	14.11	
45	16	15.30	9.67	10.74	11.74	12.67							
	17	15.31	8.63	9.68	10.72	11.74	12.71	13.50					
	18	15.31	7.61	8.63	9.66	10.71	11.74	12.71	13.63				
	19	15.55	6.51	7.58	8.60	9.65	10.70	11.73	12.72	13.67	14.41		
	20	15.89	5.38	6.48	7.57	8.64	9.63	10.66	11.70	12.71	13.68	14.57	
	21	16.28		5.35	6.46	7.54	8.62	9.61	10.64	11.67	12.71	13.69	14.61
22	16.73			5.33	6.42	7.53	8.59	9.58	10.63	11.64	12.67	13.65	
50	16	14.30	9.22	10.28	11.24	12.03							
	17	14.31	8.18	9.21	10.27	11.25	12.16						
	18	14.31	7.18	8.18	9.21	10.25	11.26	12.21					
	19	14.42	6.08	7.16	8.17	9.21	10.23	11.26	12.22	13.09			
	20	14.70	4.97	6.06	7.14	8.16	9.19	10.21	11.23	12.23	13.15		
	21	15.06		4.94	6.05	7.13	8.18	9.16	10.18	11.22	12.24	13.17	14.00
22	15.45			4.91	6.01	7.10	8.16	9.14	10.17	11.20	12.20	13.17	

17.56 kW
3 Phase 1 Stage

HEATING PERFORMANCE

WB TEMP ON OD COIL - °C	HEATING CAPACITY - kW									
	AT DB ENTERING INDOOR - °C									
	16		18		20		22		24	
	TH	IH	TH	IH	TH	IH	TH	IH	TH	IH
-10	10.94	10.28	10.89	10.24	10.84	10.19	10.78	10.14	10.74	10.09
-8	11.67	10.86	11.61	10.80	11.55	10.74	11.49	10.68	11.42	10.62
-6	12.42	11.43	12.35	11.36	12.28	11.30	12.25	11.27	12.19	11.21
-4	13.22	11.83	13.13	11.75	13.10	11.72	13.02	11.65	12.94	11.58
-2	14.10	12.26	14.00	12.18	13.91	12.10	13.82	12.02	13.74	11.95
0	14.94	12.85	14.83	12.76	14.77	12.70	14.66	12.61	14.57	12.53
2	15.79	14.05	15.66	13.94	15.54	13.83	15.43	13.73	15.32	13.63
4	16.71	15.87	16.54	15.71	16.44	15.62	16.33	15.52	16.21	15.40
6	17.68	17.68	17.52	17.52	17.38	17.38	17.24	17.24	17.13	17.13
8	18.68	18.68	18.51	18.51	18.35	18.35	18.21	18.21	18.07	18.07
10	19.71	19.71	19.54	19.54	19.37	19.37	19.21	19.21	19.05	19.05
12	20.79	20.79	20.60	20.60	20.41	20.41	20.23	20.23	20.05	20.05
14	21.90	21.90	21.70	21.70	21.49	21.49	21.29	21.29	21.10	21.10
16	23.06	23.06	22.82	22.82	22.60	22.60	22.38	22.38	22.17	22.17
18	24.25	24.25	24.00	24.00	23.75	23.75	23.50	23.50	23.26	23.26

TH - Total Heating Capacity (kW).
IH - Integrated Heating Capacity (kW).
Includes defrost losses.

AIRFLOW CORRECTION MULTIPLIER

% VARIATION	-9.41%	-5%	NOMINAL	5%	5.88%
INDOOR AIRFLOW (l/s)	770	808	850	893	900
TOTAL COOLING	0.982	0.991	1.00	1.006	1.007
SENSIBLE COOLING	0.946	0.971	1.00	1.027	1.032
HEATING FACTOR	0.996	0.998	1.00	1.002	1.002

NOTES:

- No allowance has been made for the effect of indoor fan motor.
- Selection tables are based on nominal airflows. Correction factors must be applied for selection away from these conditions.

PIPE LENGTH CORRECTION MULTIPLIER

	5 m	10 m	20 m	30 m	40 m	50 m	60 m
COOLING	1.000	0.992	0.975	0.959	0.943	0.927	0.912
HEATING	1.000	1.000	1.000	1.000	1.000	1.000	1.000

Correction multipliers are based on horizontal pipe runs.



DIMENSIONS

CRA170T

OUTDOOR UNIT CRA170T

OVERALL NOMINAL DIMENSION (H x W x L)
= 1045 x 1460 x 580

**PLEASE NOTE THAT UNDER ALL CIRCUMSTANCES,
CONDENSER AIR MUST NOT RECIRCULATE BACK ONTO
CONDENSER COIL. KEEP ALL CLEARANCES FREE OF ANY
OBSTRUCTIONS**

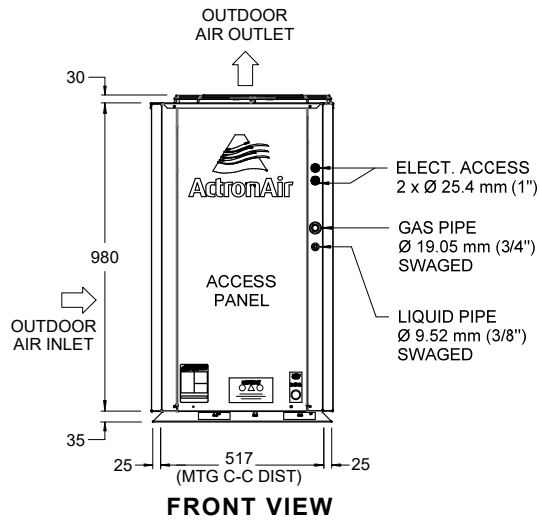
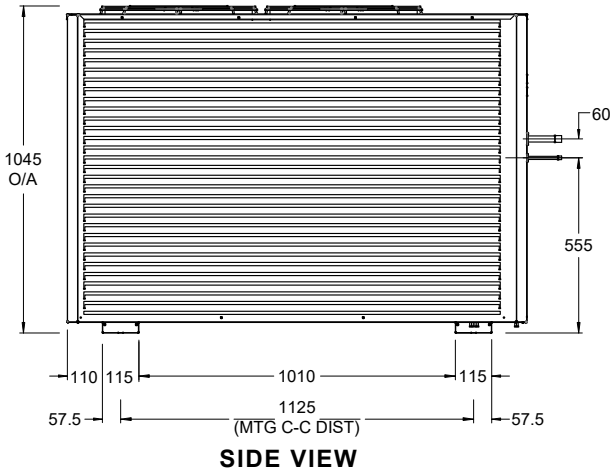
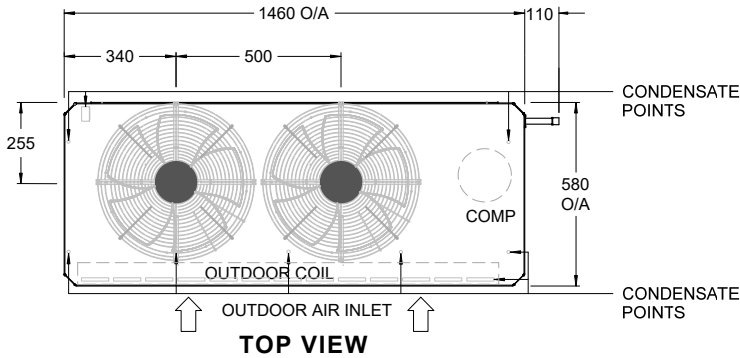

UNIT MODEL NUMBER	UNIT WEIGHT (kg)	CORNER WEIGHT (kg)			
		A	B	C	D
CRA170T	155	17	54	28	56

MINIMUM SERVICE ACCESS AREAS AND AIRFLOW CLEARANCES

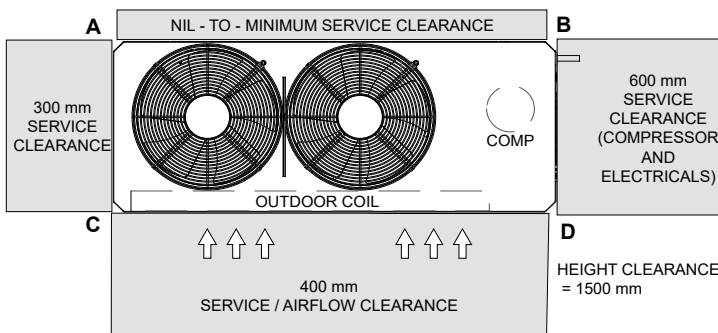

NOTES:

- Do not scale drawing. All dimensions are in mm unless specified. Refer to corresponding unit dimensional drawing for mounting hole details.
- Service Access Areas and Spaces for Airflow Clearances given above are suggested minimum based on the condition that the spaces around the units are free from any obstructions and a walkway passage of 1000mm between the units or between the unit and the outside perimeter is available.
- Minimum service access areas and spaces for airflow clearances are responsibilities of the installer, ActronAir will not be held liable for any extra charges incurred due to lack of access and space for airflow.
- Under all circumstances, condenser air must not recirculate back onto condenser coil. Keep all clearance free of any obstructions.
- STACKING OF UNITS: Ensure that minimum airflow and clearances are met.
- Refer to pipe Connection Details on Specifications Sheet.
- MTG C-C DIST = Mounting Centre to Centre Distance.
- Use M12 bolt for feet mounting.

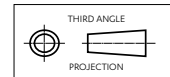

INDOOR UNIT EVA170S

OVERALL NOMINAL DIMENSION (H x W x L)
= 412 x 1290 x 615
SUPPLY DUCT (H x W) = 300 x 715
RETURN DUCT = 340 x 1100
DRAIN CONNECTION = 20 mm OD

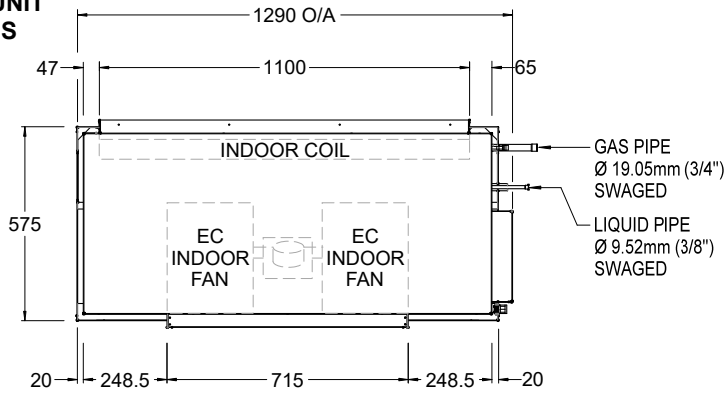

TOP VIEW

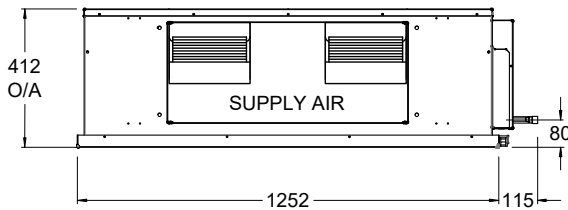

FRONT VIEW

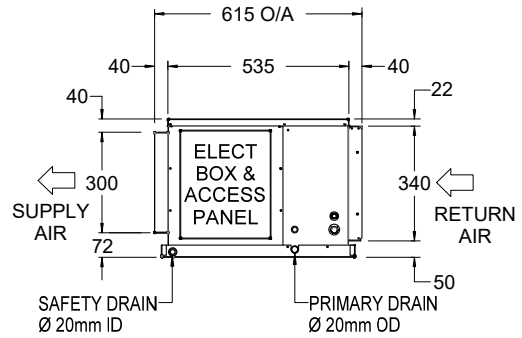

SIDE VIEW

UNIT MODEL NUMBER	UNIT WEIGHT (kg)
EVA170S	56

MINIMUM SERVICE ACCESS AREAS AND AIRFLOW CLEARANCES

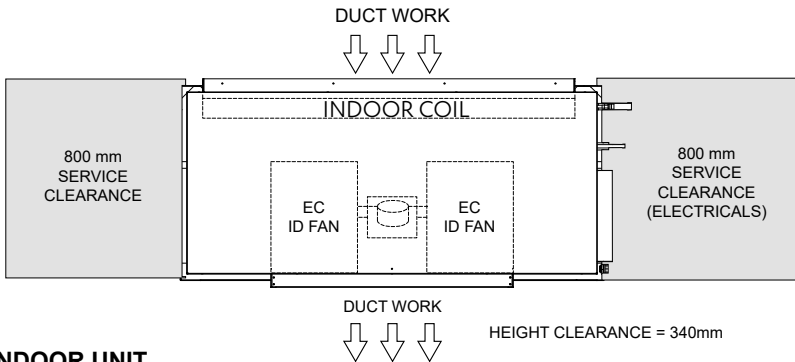

NOTES:

- Do not scale drawing. All dimensions are in mm unless specified.
- Service Clearances given are suggested minimum based on the condition that the spaces around the units are free from any obstructions and a walkway passage of 1000mm between the units or between the unit and the outside perimeter is available.
- Minimum service access clearances are responsibilities of the installer, ActronAir will not be held liable for any extra charges incurred due to lack of access.

INDOOR UNIT FAN CURVE*

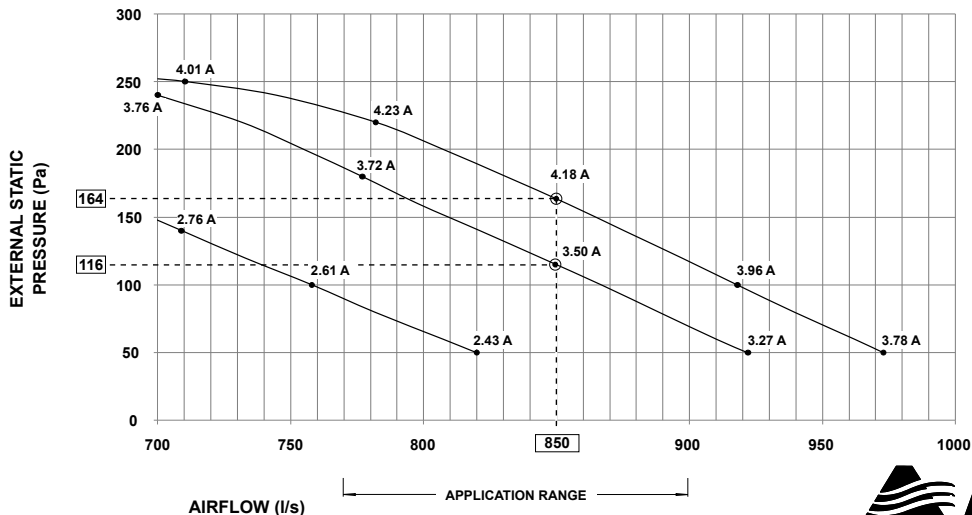

* Performance Fan Curve shown is at Dry Coil Condition for FD 9x7 - 1/2Hp EC Fan.



17.56 kW
3 Phase 1 Stage

INDOOR UNIT - WITH 3RD PARTY CONTROL

AIRFLOW (l/s)	EXTERNAL STATIC PRESSURE (Pa)															
	50		75		100		125		150		175		200		225	
	% PWM	W	% PWM	W	% PWM	W	% PWM	W	% PWM	W	% PWM	W	% PWM	W	% PWM	W
770	66	288	70	333	74	371	79	422	84	474	88	512	93	561	98	610
775	67	294	71	335	75	374	80	428	85	476	89	518	94	571	99	618
800	71	315	75	358	80	404	85	457	89	502	93	550	99	610	MOTOR / BLOWER LIMIT	
825	74	340	79	383	84	436	88	482	93	535	97	584				
850	78	364	83	413	88	463	92	513	97	568						
875	82	390	87	445	92	494	96	549								
900	87	431	92	483	97	547										

3 Phase
1 Stage
17.56 kW

NOTES:

W = Indoor Fan Power, Watts

PWM = Pulse Width Modulation Setting, % PWM

Default PWM Setting = 90% PWM (Medium Speed) at 100 Pa

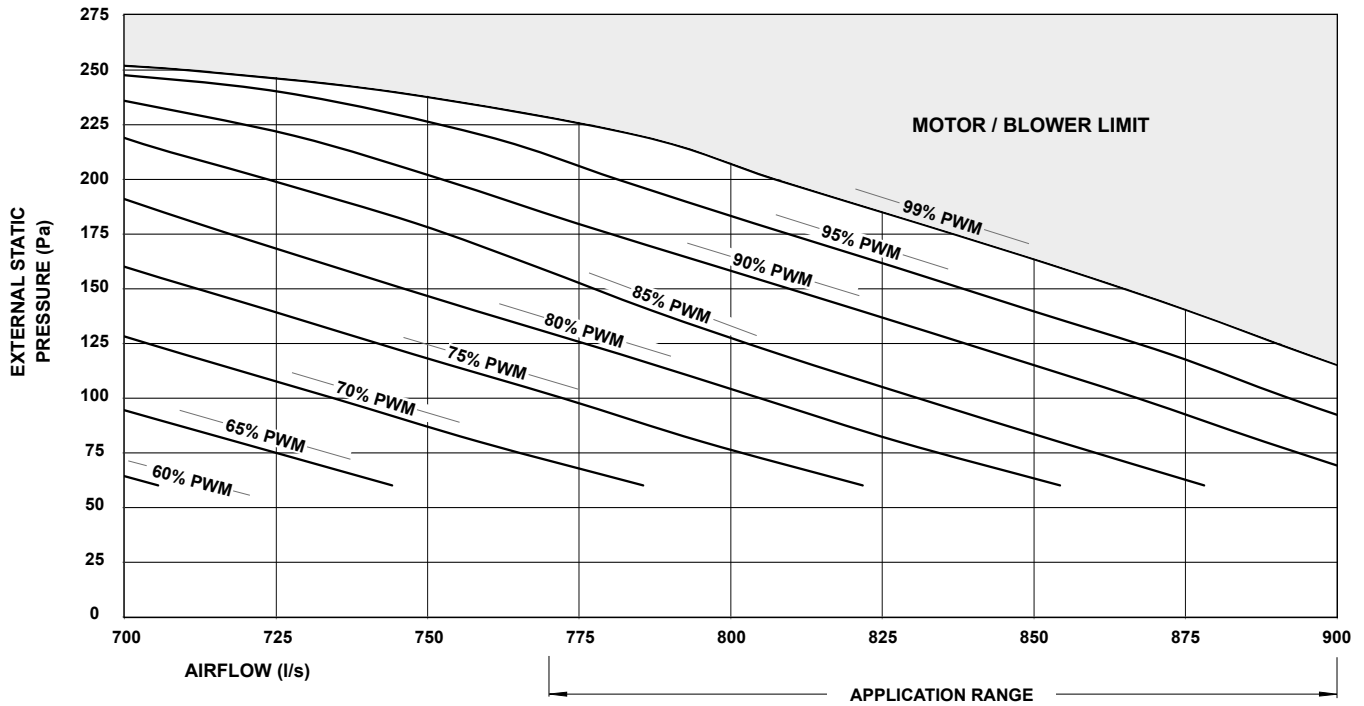

Outdoor Radiated

Sound Power Level (SWL)

Fan Speed	Sound Power Level dB(A)	Octave Band Centre Frequency (Hz), dB						
		125	250	500	1k	2k	4k	8k
Low	69.8	67.9	61.5	69.7	65.8	56.3	50.5	47.1
Medium	70.7	70.1	64.7	70.5	66.2	57.6	52.4	47.6
High	73.1	74.6	71.3	72.5	67.7	61.5	56.1	49.0

Indoor Outlet

Sound Power Level (SWL)

Airflow Setting	Airflow l/s	Sound Power Level dB(A)	Octave Band Centre Frequency (Hz), dB						
			125	250	500	1k	2k	4k	8k
Nominal	850	75.0	72.8	73.8	72.9	70.2	66.1	63.0	58.0

17.56 kW
3 Phase 1 Stage

OUTDOOR RADIATED

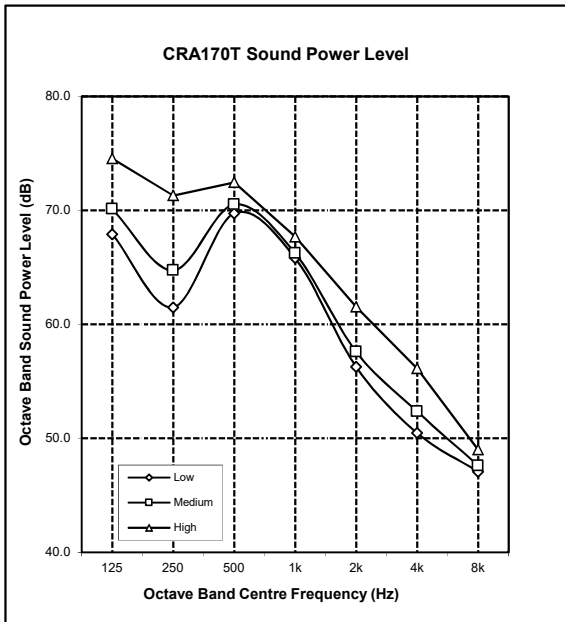

INDOOR OUTLET

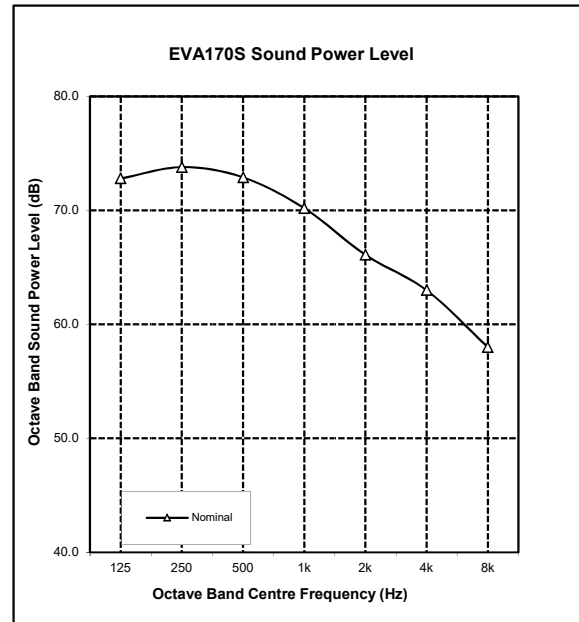

NOTE:

Radiated sound power levels are based on ISO 3743-1.



SPECIFICATIONS

CRA170T / EVA170S

CONSTRUCTION	
CABINET (Indoor Unit)	0.5 - 0.9 mm Galvanized Steel
CABINET (Outdoor Unit)	0.9 - 1.2 mm Galvanized Steel
SURFACE FINISH (Outdoor Unit)	65 μ Baked Polyester Powder Coat

INSULATION (Indoor Unit)	
TYPE	Foil Faced Polyethylene Expanded Polystyrene

ELECTRICAL	
OUTDOOR UNIT	
Power Supply - 50 Hz	400 Volts x 3 Phase + N
Voltage Range (min - max)	380 V - 440 V
Full Load Amps*	12.3
Rated Load Amps**	8.7
Approximate Starting Amps	64.5
IP Rating	IP44

INDOOR UNIT	
Power Supply - 50 Hz	230 Volts x 1 Phase + N
Voltage Range (min - max)	216 V - 253 V
Full Load Amps*	4.3
Rated Load Amps**	4.1
IP Rating	IP20

OUTDOOR & INDOOR UNIT (TOTAL)	
Full Load Amps* - Phase 1	16.6
Full Load Amps* - Phase 2 & 3	11.2
Rated Load Amps**	12.8

IMPORTANT - The local electricity authority may require limits on starting current and voltage drop, please check prior to purchase.

* Full Load Amps are based on Compressor and Fan Motor's maximum expected current.

** Rated Load Amps are measured and tested in accordance with AS/NZS3823.1.2.

CABLE SIZE & CIRCUIT BREAKER SIZE	
Suggested minimum cable size should be used as a guide only, refer to the accordance with the latest edition of the AS/NZS 3000 "Australian/New Zealand Wiring Rules" for more details.	
Cable Size (main line)	2.5 mm ² (SUGGESTED MINIMUM)
Cable Size (indoor to outdoor wire)	1.0 mm ² (SUGGESTED MINIMUM)
Circuit Breaker (RCBO if applicable)	20.0 Amps

OUTDOOR COIL	
TUBE TYPE	Copper - Rifle Bore
FIN TYPE	Aluminium - Wave
FACE AREA (m sq)	1.29
FIN SPACING (per m)	472
COIL COATING	Hydrophilic Blue Fin Coil Coat Protection

OUTDOOR FAN	
NUMBER OF FANS x TYPE	2 x Axial
NUMBER OF BLADES PER FAN	5
DIAMETER (mm)	450
OUTPUT kW (each)	0.145
MOTOR TYPE / DRIVE TYPE	6 Pole External Rotor / Direct
FAN SPEED CONTROL	3 Speed via Capacitor
The standard type outdoor fans fitted to this unit will accept up to 5 Pa of external static resistance.	

INDOOR COIL	
TUBE TYPE	Copper - Rifle Bore
FIN TYPE	Aluminium - Louvre
FACE ARE (m sq)	0.41
FIN SPACING (per m)	472
COIL COATING	Hydrophilic Blue Fin Coil Coat Protection

INDOOR FAN	
NUMBER OF FANS x TYPE	1 x Twin Deck Centrifugal EC Fan
DIAMETER / WIDTH (mm)	240 x 180
OUTPUT (kW) / INPUT (kW)	0.373
MOTOR TYPE / DRIVE TYPE	Variable Speed EC Motor / Direct

COMPRESSOR	
NUMBER PER UNIT x TYPE	1 x Scroll (Hermetic)
FULL LOAD AMPS	11.2
LOCKED ROTOR AMPS	64.5
STARTING METHOD	D.O.L. (optional soft starter)

REFRIGERATION SYSTEM	
REFRIGERANT TYPE	R-410A
EXPANSION CONTROL	Direct Expansion Orifice
FACTORY CHARGE (grams)	7350
PRE-CHARGE LENGTH (metres)	15
ADDITIONAL REF. CHARGE (gm/m)	50

FILTER DRIER	
CONNECTION SIZE & TYPE	9.52 mm (3/8") ODF Soldered Bi-Flow
FACTORY SUPPLIED / FITTED	No

INTERCONNECTING PIPE RUN	
MAX. PIPE LENGTH (metres)	60
MAX. VERTICAL LENGTH (metres)	20 (Included in Max. Pipe Length)
FIELD PIPE SIZES	
Liquid Pipe	9.52 mm (3/8")
Gas Pipe	19.05 mm (3/4")

PIPE CONNECTIONS		
Indoor	Liquid Pipe	9.52 mm (3/8") Swaged to fit 9.52 mm (3/8") field pipe
	Gas Pipe	19.05 mm (3/4") Swaged to fit 19.05 mm (3/4") field pipe
Outdoor	Liquid Pipe	9.52 mm (3/8") Swaged to fit 9.52 mm (3/8") field pipe
	Gas Pipe	19.05 mm (3/4") Swaged to fit 19.05 mm (3/4") field pipe
CONNECTION TYPE		Solder
Insulate both gas and liquid pipes separately.		

PROTECTION DEVICES	
HIGH PRESSURE CUTOUT SWITCH	Nonadjustable (Automatic Reset)
LOW PRESSURE CUTOUT SWITCH	Nonadjustable (Automatic Reset)
COMPRESSOR MOTOR TEMP.	Internal Thermal Cut-Out
INDOOR FAN OVERLOAD	Internal Thermal Cut-Out
OUTDOOR FAN OVERLOAD	Internal Thermal Cut-Out
SUMP HEATER WATTS *	30 W during Compressor Off Cycle
* Crankcase Heater is to be disconnected for pipe lengths 8 m or less.	

ELECTRIC CONTROLS	
DEFROST METHOD	Reverse Cycle
DEFROST TYPE	Adaptive Demand Defrost
CONTROL CIRCUIT BREAKER	10.0 Amps
CONTROL FIELD WIRING	2 Core 14 / 0.20 Screened Cable
WALL CONTROLLER / SENSOR	Cat5e UTP (AWG 24) Data Cable
FIELD WIRING	

OPERATING RANGE			
It is essential that the unit is correctly sized for the application and operates within its recommended range of operating conditions as shown below.			
MODE	RANGE	INDOOR AIR INTAKE TEMPERATURE	OUTDOOR AIR INTAKE TEMPERATURE
Cooling	Max.	30°C DB / 22°C WB	50°C DB
	Min.	20°C DB / 16°C WB	5°C DB
Heating	Max.	24°C DB	21°C DB / 16°C WB
	Min.	16°C DB	-10°C DB

AIR FILTERS
All return air including fresh air must have adequate filters supplied and fitted by the installing contractor. Filters must be located in accessible location between the return air grille and the unit.
ActronAir does not supply or make any provisions for return air filter.

- UNIT COMPLIANCE**
- AS/NZS 3823.2 (MEPS)
 - AS/NZS 4755.3.1 (DRM1, 2 and 3)
 - AS/NZS CISPR 14.1 (EMC)
 - AS/NZS 60335.2.40 (Safety)



3 Phase
1 Stage

17.56 kW

WIRING DIAGRAM

CRA170T / EVA170S

17.56 kW
3 Phase 1 Stage

LEGEND

CB	CIRCUIT BREAKER
CM	COMPRESSOR MOTOR
CCH	CRANKCASE HEATER
CMC	COMPRESSOR MOTOR CONTACTOR
ECF	EMI FILTER
HP	HIGH PRESSURE SWITCH
IF	INDOOR FAN MOTOR
ICB	INDOOR CONTROL BOARD
LP	LOW PRESSURE SWITCH
LSC	LOW SPEED CAPACITOR
MSC	MEDIUM SPEED CAPACITOR
OF	OUTDOOR FAN MOTOR
OCB	OUTDOOR CONTROL BOARD
OFRC	OUTDOOR FAN RUN CAPACITOR
RV	REVERSING VALVE
TX	ZONE TRANSFORMER 240/24V AC
TWC	TOUCH WALL CONTROLLER
WC	WALL CONTROLLER

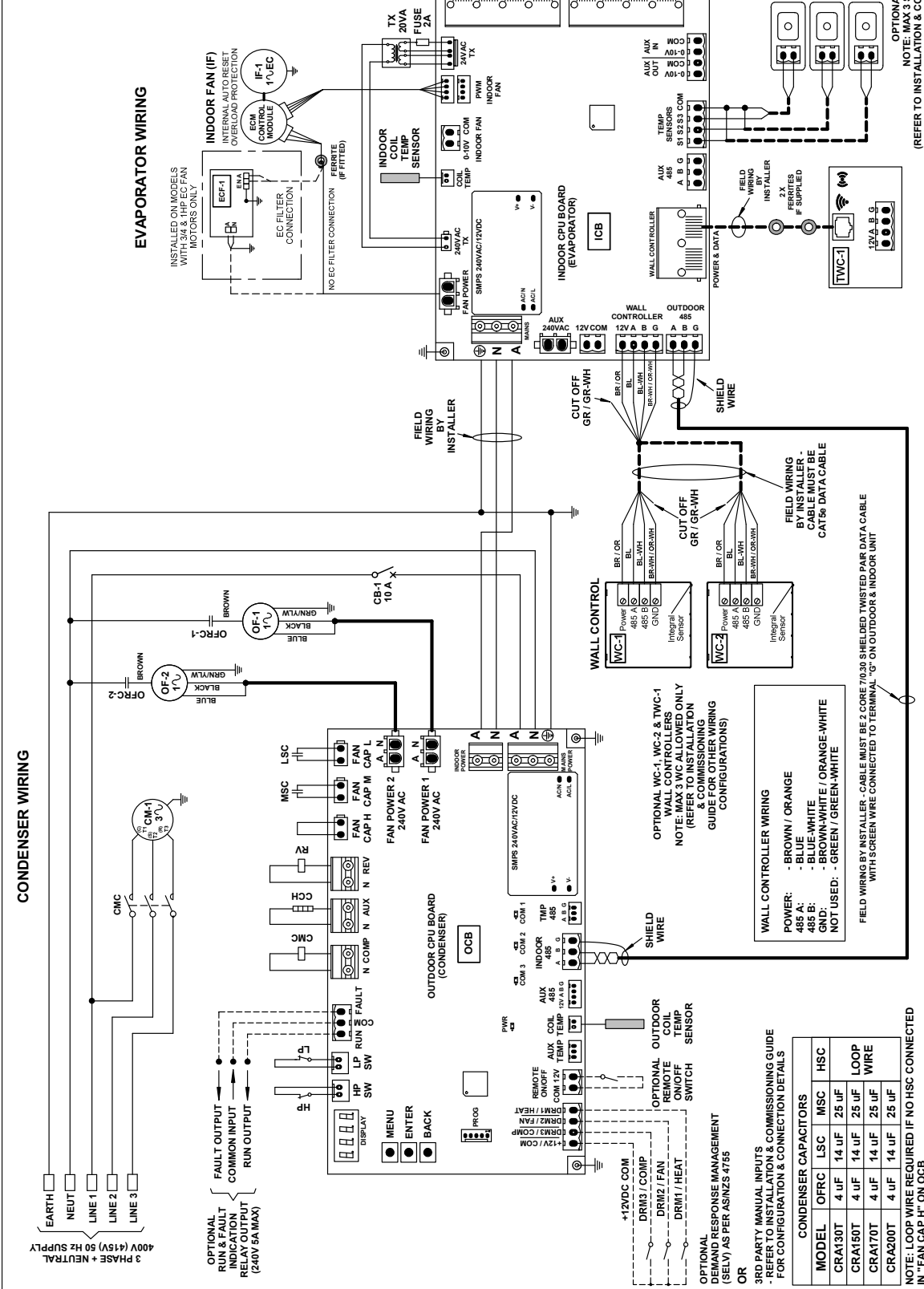

Base Model No:	CRA130/150/170/200T	Variation Code:	STANDARD
Description:	UNO SERIES CONTROL SYSTEM WIRING DIAGRAM WITH INZONE SERIES INDOOR BOARD & WALL CONTROL		
Drawn:	RL	Date:	12-03-2019
Approved:	JL	Date:	20-09-2022
Revision:	D	Drawing No:	WD2202
Size:	A4		



This drawing remains the intellectual property of Actron Engineering Pty Ltd. Reproduction, modification and/or distribution are prohibited without written consent.

Rev.	Description	By	Date
D	ADDED ZONE MOTOR, SENSOR & CONTROLLER	3592	16-09-2022
C	ADDED FERRITE TO TWC-1	3571	16-09-2022
B	CHANGED WC WIRING COLOUR REFERENCE REMOVED WC-3 & ADDED TWC-1	3280	01-06-2020

Rev. Description

Original

H OUTDOOR UNIT - HORIZONTAL DISCHARGE FANS

OVERALL NOMINAL DIMENSION (H x W x L)
= 1015 x 1460 x 610
USE M12 BOLT FOR FEET MOUNTING

NOTES:

1. All dimensions are in mm unless specified.
2. Do not scale drawing.
3. Additional Full Coil Coat Protection option available on all units.
4. Suggested Service Clearance and Airflow Allowances are based on conditions that the spaces are free from obstructions and walkway passage of 1000 mm is available.
5. Minimum service access areas are responsibilities of the installer.
6. Maximum External Static of Outdoor Fans is 5 Pa.
7. Multiple drainage is as illustrated on the standard outdoor model.

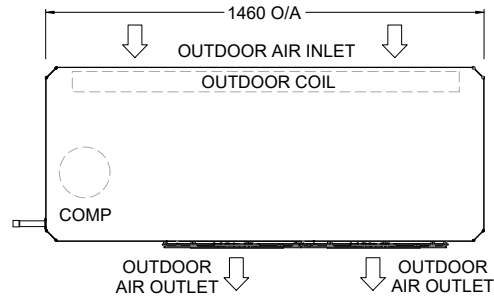
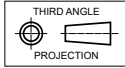

TOP VIEW

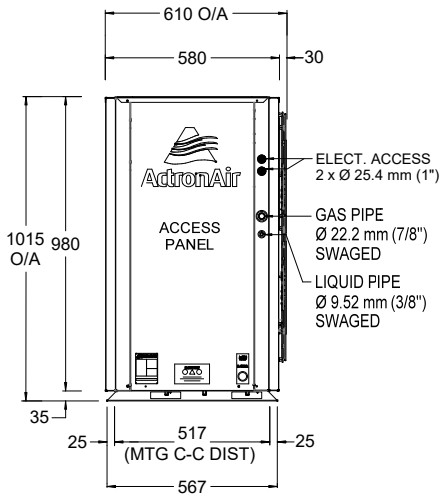

SIDE VIEW

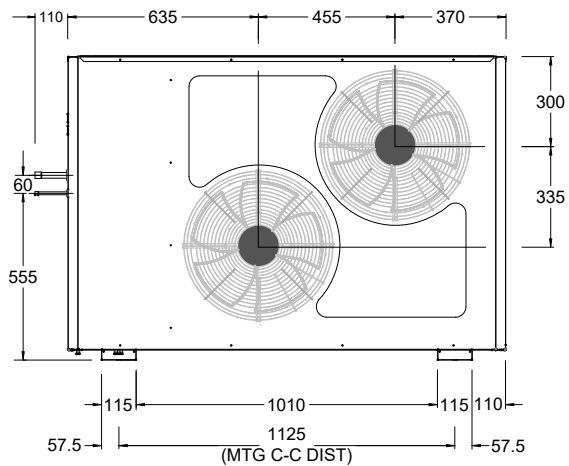

FRONT VIEW

3 Phase
1 Stage
17.56 kW

MINIMUM SERVICE ACCESS CLEARANCES & AIRFLOW SPACE ALLOWANCES

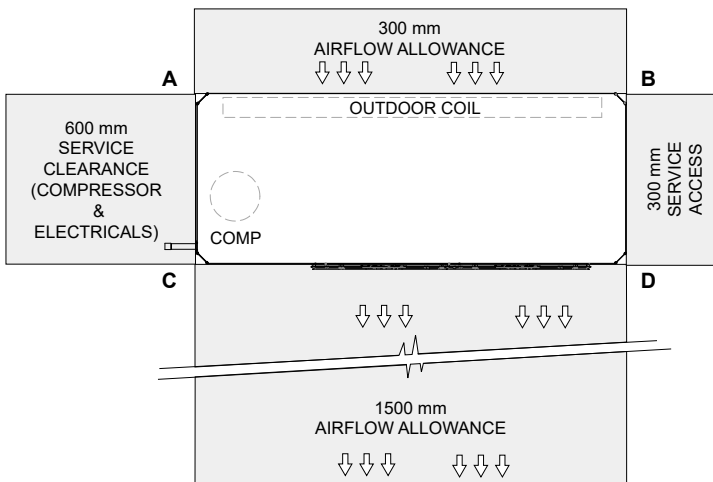

TOP VIEW

PLEASE NOTE THAT UNDER ALL CIRCUMSTANCES, CONDENSER AIR MUST NOT RECIRCULATE BACK ONTO CONDENSER COIL. KEEP ALL CLEARANCES FREE OF ANY OBSTRUCTIONS

STACKING OF UNITS	
ONE IN FRONT OF THE OTHER (DISTANCE BET. A & B)	SIDE BY SIDE (DISTANCE BET. A & C)
600 mm	1500 mm

V INDOOR UNIT - UPRIGHT FAN COIL WITH VERTICAL DISCHARGE

OVERALL NOMINAL DIMENSION (H x W x L)
 = 875 x 1275 x 405
 SUPPLY DUCT (H x W) = 300 x 715
 RETURN DUCT (H x W) = 365 x 1095
 DRAIN CONNECTION = 20 mm OD

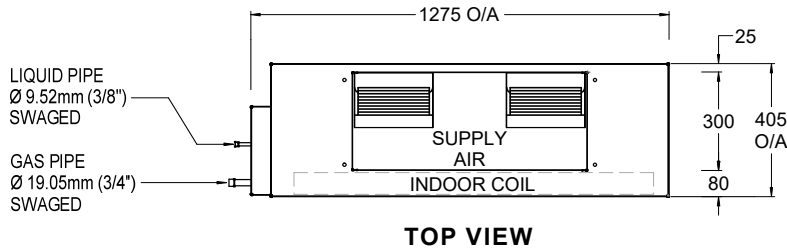

TOP VIEW

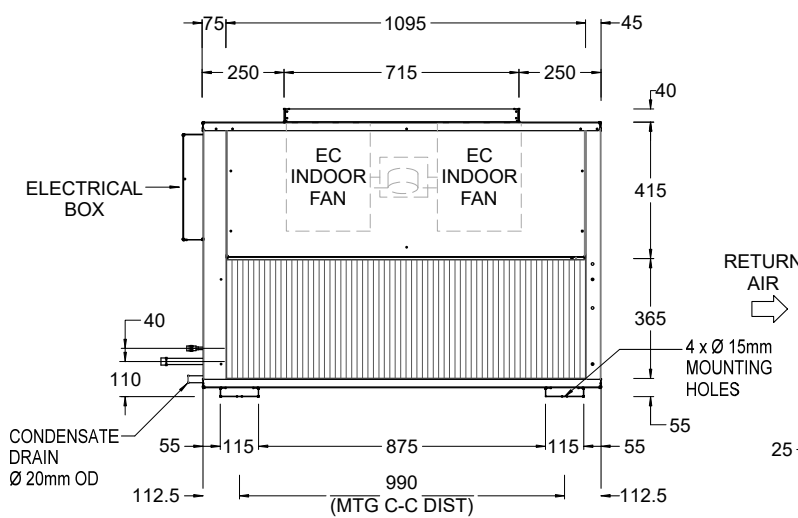

FRONT VIEW

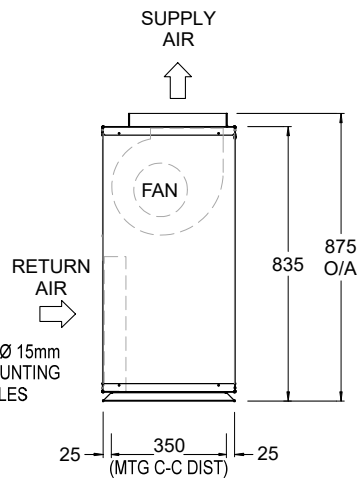

SIDE VIEW

MINIMUM SERVICE ACCESS CLEARANCES & AIRFLOW SPACE ALLOWANCES

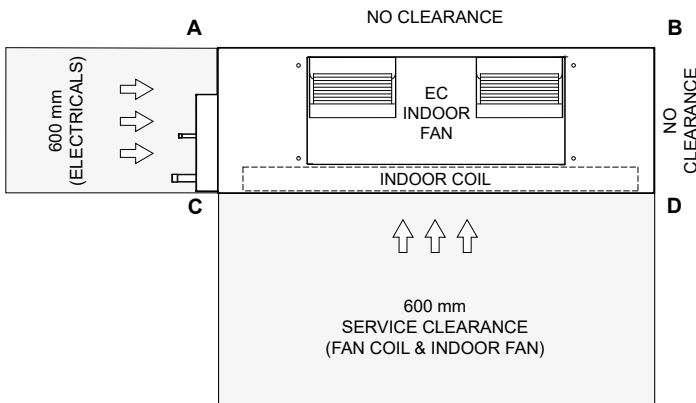

HEIGHT CLEARANCE = DUCT WORK

TOP VIEW

NOTES:

1. All dimensions are in mm unless specified.
2. Do not scale drawing.
3. Refer Fan Curve to corresponding standard EVA170S model.
4. Additional Full Coil Coat Protection option available on all units.
5. Suggested Service Clearance and Airflow Allowances are based on conditions that the spaces are free from obstructions and walkway passage of 1000 mm is available.
6. Minimum service access areas are responsibilities of the installer.

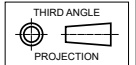

STACKING OF UNITS	
ONE IN FRONT OF THE OTHER (DISTANCE BET. A & B)	SIDE BY SIDE (DISTANCE BET. A & C)
600 mm	1000 mm

17.56 kW
 3 Phase 1 Stage