

PACKAGE UNIT



UNIT FEATURES

- Tru-Inverter™ Variable Speed Compressor and Drive Technology
- Pre-charged with R-410A Refrigerant
- Multiple Speed Outdoor Fans
- 40-100% Variable Refrigeration Capacity
- Low Ambient Cooling Operation to +5 deg
- Phase Protection
- Hydrophilic Blue Coat Coil Fin Protection - Indoor and Outdoor Coils
- Removable Louvred Outdoor Coil Guard
- Adaptive Demand Defrost
- EC Variable Speed Indoor Fan + Reduce Fan Airflow Feature
- Adjustable Indoor Airflow
- Foil Faced Polyethylene Insulation
- Active Power Factor Correction
- Bi-Flow Electronic Expansion Valves

UNIT OPTIONS

- Additional Full Coil Coat Protection

CONTROL OPTIONS AND FEATURES

ActronAir LC7-2 (BCA Compliant)

- Available in White or Grey
- 7-day Programmable Controller with 2 Events per Day
- 24-hour ON/OFF Timer
- Temperature Setback
- After Hours Time
- Auto / Cool / Heat / Fan Only / Night Modes Functions
- Auto / Continuous Indoor Fan Operation
- Optional 2nd and 3rd Controllers with Mimic Logic
- On-Board Temperature Sensor

ActronAir Neo

- 7" Colour Touch Screen Master Controller
- In-built Wi-Fi and Blue-Tooth
- Neo Connect App
- On-Board Temperature, Humidity and Proximity Sensor
- Optional wireless Zone Sensor
- Available in White or Black

ActronAir Group Control

ActronAir BMS ICUNO (Modbus 485)

THIRD PARTY CONTROL

- Manual Control Inputs (Heat, Cool and Fan Operation)
- Analogue Input (Fan and Cool Operation)

SPECIFICATION SUMMARY

UNIT MODEL	PKV180T		
	⁽¹⁾ TOTAL	⁽²⁾ NETT	
⁽³⁾ COOLING CAPACITY (kW)	MINIMUM	6.56	6.40
	RATED	16.40	16.00
	TRUMAX⁽⁹⁾	18.50	18.00
⁽⁴⁾ HEATING CAPACITY (kW)	MINIMUM	6.97	7.14
	RATED	16.60	17.00
	TRUMAX⁽⁹⁾	18.50	19.00
⁽³⁾ SENSIBLE CAPACITY (kW)	RATED	13.68	13.28
⁽⁵⁾ COOLING INPUT POWER (kW)	RATED	4.96	
⁽⁵⁾ HEATING INPUT POWER (kW)	RATED	4.85	
EER	RATED	3.31	3.23
COP	RATED	3.42	3.51
⁽⁶⁾ INDOOR AIRFLOW (l/s) - MIN. / NOMINAL / MAX.	680 / 850 / 1020		
MINIMUM AIRFLOW WHEN IN MODULATION (l/s)	220		
OUTDOOR SOUND PRESS. LEVEL @ 3M dB(A) - LOW / HIGH	50.0 / 53.0		
OUTDOOR SOUND POWER LEVEL dB(A) - LOW / HIGH	69.3 / 72.1		
POWER SUPPLY	400V/3Ph+N/50Hz		
⁽²⁾ RATED LOAD AMPS	9.8		
⁽⁷⁾ FULL LOAD AMPS	14.5		
⁽⁸⁾ CIRCUIT BREAKER AND CABLE AMPS	20		
APPROXIMATE STARTING AMPS	< 45		
POWER FACTOR	0.96		
WEIGHT (kg)	267		

- ⁽¹⁾ Based on unit rating excluding indoor fan kW.
- ⁽²⁾ Measured and tested in accordance with AS/NZS 3823.1.2.
- ⁽³⁾ At 27°C DB / 19°C WB entering air temperatures and 35°C ambient.
- ⁽⁴⁾ At 20°C DB entering air temperature and 7°C DB / 6°C WB ambient.
- ⁽⁵⁾ Total input power excludes indoor fan kW. Nett input power includes indoor fan kW.
- ⁽⁶⁾ Max. - Min. airflow application range irrespective of external static pressure.
- ⁽⁷⁾ Full Load Amps are based on compressor and fan motors' maximum expected current.
- ⁽⁸⁾ See Specifications sheet for cable size and circuit breaker size details.
- ⁽⁹⁾ **TRUMAX** - Maximum Capacity.

Note: Use nett input power to estimate running cost.

3 Phase
1 Stage
16.40 kW



CAPACITY SELECTION DATA

PKV180T

COOLING PERFORMANCE

AIR ENTERING		TOTAL CAPACITY kW	TOTAL SENSIBLE CAPACITY - kW										
OUTDOOR DB - °C	INDOOR WB - °C		AT DB TEMPERATURE ONTO INDOOR COIL - °C										
			20	21	22	23	24	25	26	27	28	29	30
25	16	16.67	10.81	11.46	12.11	12.76	13.41	14.10					
	17	17.20	10.41	10.93	11.44	12.35	13.26	13.82	14.37	14.92			
	18	17.73	10.02	10.40	10.77	11.94	13.11	13.53	13.95	14.83	15.70		
	19	18.30	9.83	10.13	10.43	11.17	11.91	12.97	14.03	14.23	14.43	14.72	
	20	18.88	9.63	9.99	10.39	10.68	10.96	11.99	13.01	13.83	14.66	14.75	14.84
	21	19.31		9.86	10.37	10.61	10.85	11.58	12.30	13.11	13.79	14.30	14.80
22	19.75			10.35	10.55	10.74	11.17	11.60	12.39	12.93	13.85	14.76	
30	16	16.11	10.48	11.18	11.88	12.55	13.23	13.76					
	17	16.65	9.85	10.50	11.15	12.07	13.00	13.50	14.00	14.50			
	18	17.20	9.22	9.82	10.43	11.59	12.76	13.24	13.71	14.15	14.59		
	19	17.55	9.19	9.60	10.00	10.79	11.59	12.72	13.84	13.92	14.00	14.50	
	20	18.06	9.17	9.48	9.94	10.26	10.59	11.63	12.68	13.54	14.12	14.39	14.67
	21	18.39		9.37	9.91	10.24	10.58	11.29	12.00	12.71	13.36	13.98	14.60
22	18.72			9.87	10.22	10.57	10.95	11.33	11.88	12.61	13.57	14.54	
35	16	15.84	9.97	10.70	11.43	12.28	13.13	13.68					
	17	15.86	9.32	10.02	10.72	11.73	12.75	13.34	13.93	14.52			
	18	15.89	8.67	9.34	10.01	11.18	12.36	12.99	13.63	13.81	14.00		
	19	16.40	8.43	9.04	9.64	10.41	11.17	12.31	13.45	13.68	13.91	14.43	
	20	16.99	8.20	8.89	9.17	9.59	10.02	11.15	12.28	13.17	13.98	14.17	14.52
	21	17.41		8.73	8.93	9.44	9.95	10.69	11.44	12.31	13.10	13.73	14.43
22	17.83			8.70	9.29	9.88	10.23	10.59	11.45	12.23	13.28	14.34	
40	16	14.45	9.73	10.48	11.24	12.04	12.84	13.44					
	17	14.94	8.91	9.69	10.48	11.47	12.45	13.06	13.67	14.29			
	18	15.44	8.09	8.91	9.73	10.89	12.06	12.69	13.31	13.66	14.00		
	19	15.73	8.05	8.31	8.58	9.71	10.85	11.94	13.03	13.17	13.77	14.37	
	20	16.30	8.01	8.02	8.09	8.87	9.66	10.87	12.07	12.69	14.09	14.23	14.47
	21	16.75		7.72	7.84	8.61	9.38	10.22	11.05	11.85	13.01	13.64	14.31
22	17.20			7.60	8.34	9.09	9.56	10.04	11.00	11.93	13.04	14.15	
45	16	13.72	9.40	10.08	10.77	11.64	12.52	13.08					
	17	14.12	8.92	9.46	9.99	11.06	12.13	12.73	13.33	13.94			
	18	14.51	8.45	8.83	9.21	10.48	11.74	12.38	13.02	13.51	14.00		
	19	14.83	7.93	8.23	8.52	9.53	10.54	11.68	12.82	13.25	13.75	14.24	
	20	15.26	7.42	7.92	7.96	8.64	9.32	10.49	11.66	12.74	13.83	14.07	14.31
	21	15.64		7.62	7.68	8.40	9.12	9.84	10.57	11.61	12.70	13.40	14.10
22	16.02			7.41	8.16	8.91	9.19	9.48	10.47	11.57	12.73	13.88	
50	16	12.92	9.07	9.46	9.85	11.04	12.22	12.95					
	17	13.35	8.29	8.87	9.45	10.65	11.84	12.57	13.30	14.02			
	18	13.78	7.51	8.28	9.05	10.25	11.46	12.18	12.91	13.17	13.44		
	19	14.01	7.35	7.58	7.81	9.03	10.26	11.41	12.56	12.89	13.21	13.54	
	20	14.40	7.18	7.22	7.41	8.25	9.08	10.24	11.40	12.32	13.23	13.42	13.60
	21	14.84		6.87	7.21	8.02	8.83	9.55	10.26	10.98	12.28	12.92	13.56
22	15.27			7.02	7.80	8.57	8.85	9.13	9.65	11.33	12.42	13.52	

HEATING PERFORMANCE

WB TEMP ON OD COIL - °C	TOTAL HEATING CAPACITY - kW									
	AT DB ENTERING INDOOR - °C									
	16		18		20		22		24	
	TH	IH	TH	IH	TH	IH	TH	IH	TH	IH
-10	10.49	10.07	10.44	10.03	10.40	9.98	10.34	9.93	10.30	9.88
-8	11.19	10.63	11.13	10.57	11.07	10.51	11.01	10.46	10.95	10.40
-6	11.90	11.18	11.82	11.11	11.76	11.06	11.73	11.03	11.68	10.97
-4	12.65	11.64	12.57	11.56	12.54	11.53	12.46	11.46	12.39	11.40
-2	13.48	12.00	13.40	11.92	13.31	11.84	13.22	11.76	13.14	11.70
0	14.29	12.57	14.18	12.48	14.12	12.43	14.02	12.34	13.93	12.26
2	15.09	13.73	14.97	13.62	14.85	13.51	14.75	13.42	14.64	13.32
4	15.96	15.96	15.80	15.80	15.71	15.71	15.61	15.61	15.49	15.49
6	16.88	16.88	16.73	16.73	16.60	16.60	16.47	16.47	16.36	16.36
8	17.83	17.83	17.67	17.67	17.52	17.52	17.39	17.39	17.25	17.25
10	18.81	18.81	18.65	18.65	18.48	18.48	18.34	18.34	18.19	18.19
12	19.83	19.83	19.66	19.66	19.48	19.48	19.30	19.30	19.14	19.14
14	20.89	20.89	20.69	20.69	20.50	20.50	20.31	20.31	20.13	20.13
16	21.98	21.98	21.76	21.76	21.55	21.55	21.35	21.35	21.14	21.14
18	23.11	23.11	22.87	22.87	22.64	22.64	22.40	22.40	22.18	22.18

TH - Total Heating Capacity (kW).
IH - Integrated Heating Capacity (kW)
Includes defrost losses.

AIRFLOW CORRECTION MULTIPLIER

% VARIATION	-20%	-15%	-10%	-5%	Nominal	+5%	+10%	+15%
INDOOR AIRFLOW (l/s)	680	723	765	808	850	893	935	978
TOTAL COOLING	0.965	0.982	0.989	0.997	1.000	1.004	1.009	1.015
SENSIBLE COOLING	0.884	0.916	0.945	0.974	1.000	1.024	1.046	1.072
HEATING FACTOR	0.969	0.976	0.983	0.991	1.000	1.011	1.022	1.033

NOTES:

- No allowance has been made for the effect of indoor fan motor.
- Selection tables are based on nominal airflows.
Correction factors must be applied for selection away from these conditions.



APPLICATION RANGE (COMPRESSOR ON)

AIRFLOW (l/s)	EXTERNAL STATIC PRESSURE (Pa)											
	50		100		150		200		250		300	
	% PWM	W	% PWM	W	% PWM	W	% PWM	W	% PWM	W	% PWM	W
680	50	191	57	254	64	320	71	391	81	456	MOTOR / BLOWER LIMIT	
700	52	201	59	265	66	333	73	405	85	475		
750	58	236	65	303	72	372	79	445	93	524		
800	64	271	71	340	79	422	86	499				
850	71	315	78	386	85	468	94	558				
900	78	360	85	440	93	528						
950	85	412	93	499								
1000	93	467										
1020	96	489										

REDUCED AIRFLOW *(COMPRESSOR OFF)

AIRFLOW (l/s)	EXTERNAL STATIC PRESSURE (Pa)											
	50		100		150		200		250		300	
	% PWM	W	% PWM	W	% PWM	W	% PWM	W	% PWM	W	% PWM	W
200	11	35	18	63	23	96	28	132	32	163	37	203
250	16	48	21	76	26	110	31	148	36	188	45	230
300	18	53	24	87	30	129	34	162	39	206	51	250
350	21	63	28	106	33	142	39	192	44	235	57	285
400	23	66	31	117	37	163	43	214	48	257	64	300
450	28	89	35	137	41	184	47	235	54	295	69	348
500	32	105	39	157	45	204	52	266	59	324	76	386
550	36	122	43	175	50	233	56	288	64	357	83	426
600	41	146	48	201	55	261	61	322	69	389	91	469

NOTES

* Reduced fan airflow is the airflow during compressor OFF operation (optional feature)

W = Indoor Fan Power, Watts

PWM = Pulse Width Modulation Setting, % PWM (Adjustable through the NEO and LC7-2 Control Interface or Outdoor Board)

Default Fan Speed Value at 100Pa	
Speed	Default PWM (adjustable)
High PWM (%)	99
Medium PWM (%)	78
Low PWM (%)	57

Indoor Fan PWM Limits	
PWM High Limit	99
PWM Low Limit	50

3 Phase
1 Stage

16.40 KW

INDOOR FAN CURVE

PKV180T

16.40 kW
3 Phase 1 Stage

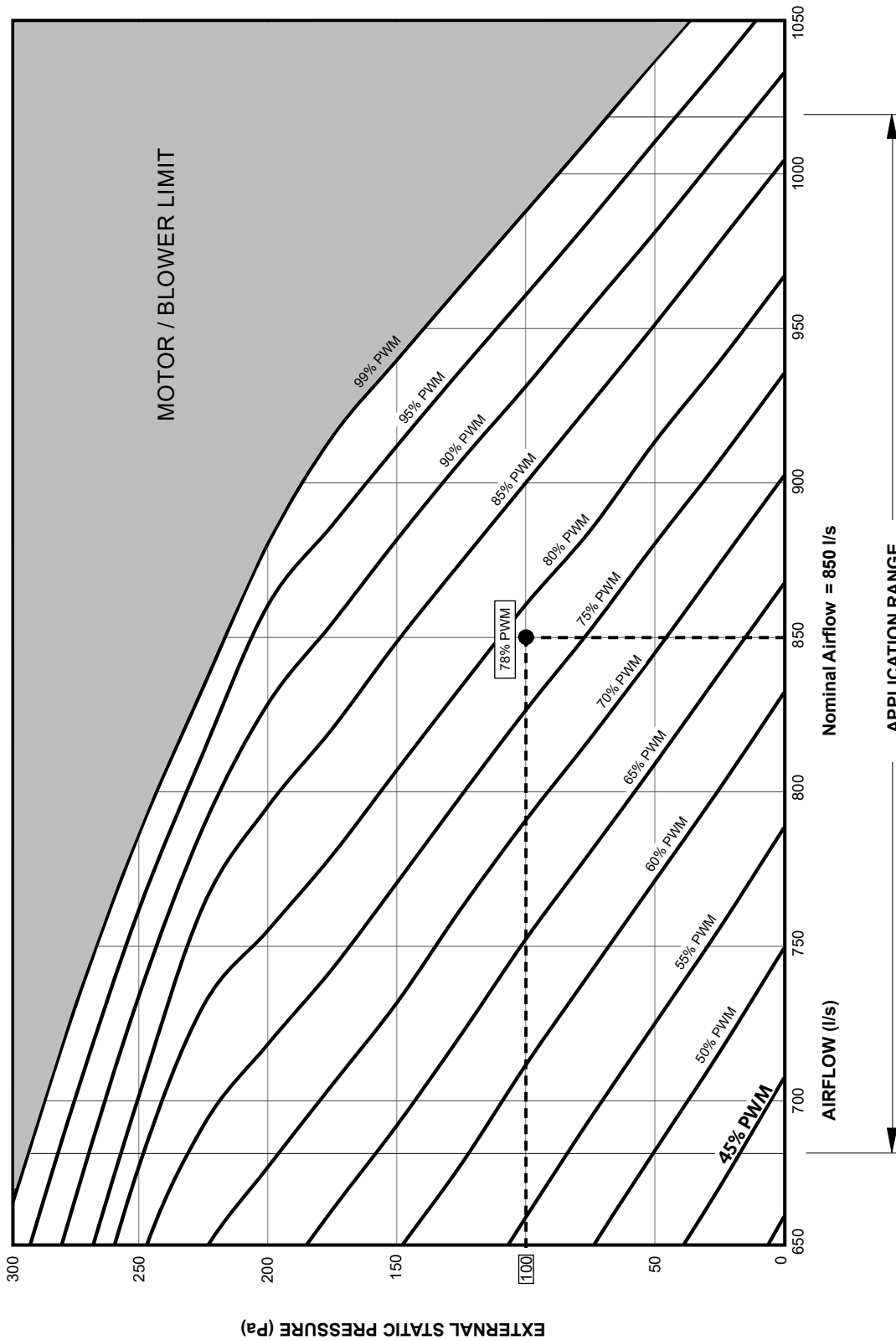

Notes:

1. Performance Fan Curve shown is at Dry Coil Condition.
2. Airflow should be reduced with respect to the moisture content in the air.
3. All data provided does not include filters. Please review filter manufacturer for application.
4. 2.5 m/s face velocity point will occur at 1025 l/s.



UNIT DIMENSIONS

PKV180T

U PACKAGE UNIT - STANDARD MODEL

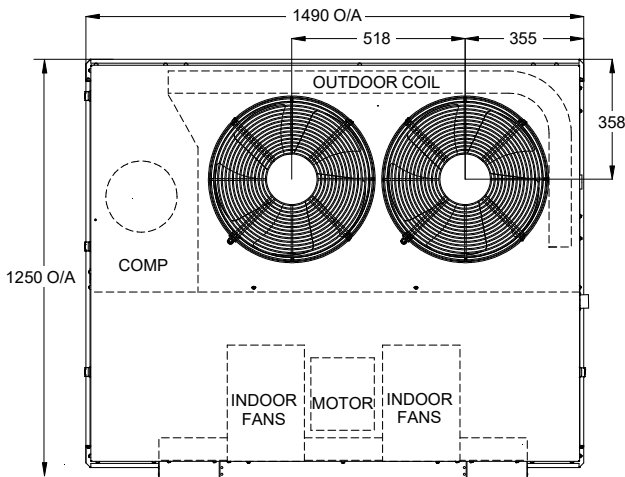

TOP VIEW

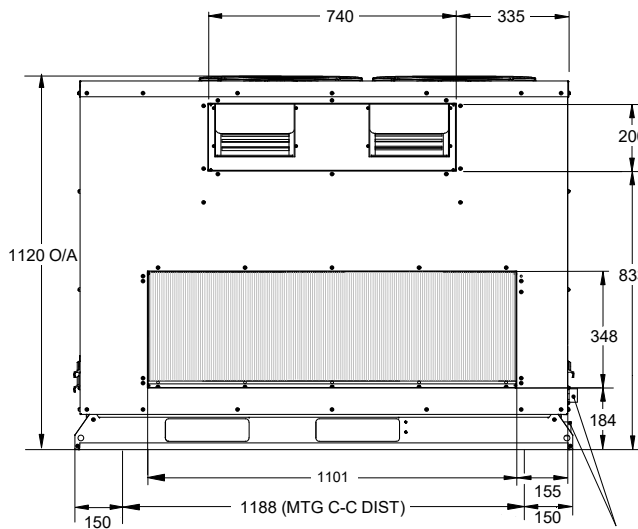

SIDE VIEW

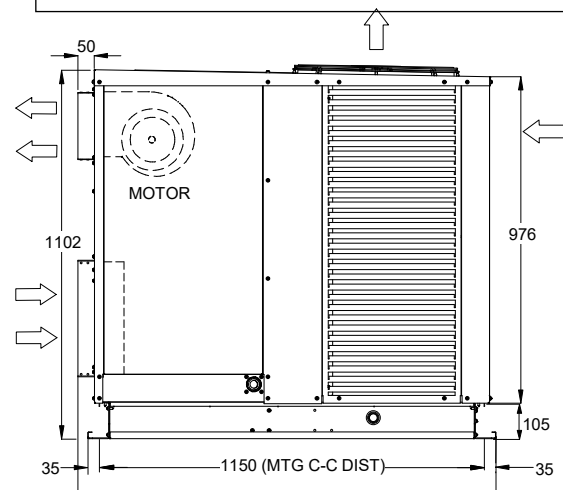

FRONT VIEW

OVERALL NOMINAL DIMENSION (H x W x D)
= 1120 x 1490 x 1250
SUPPLY DUCT (H x W) = 200 x 740
RETURN DUCT (H x W) = 348 x 1101

NOTES:

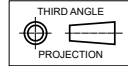

- Do not scale drawing.
- All dimensions are in mm unless specified. Refer to corresponding unit dimensional drawing for mounting hole details
- Suggested Service Clearance and Airflow Allowances are based on conditions that the spaces are free from obstructions and walkway passage of 1m is available to allow coil replacement without lifting coil over the top of the unit.
- Minimum service access areas and space for airflow clearances are responsibilities of the installer.
- Under circumstances, condenser air must not recirculate back onto condenser coil. Keep all clearances free of any obstructions.
- STACKING OF UNITS: Ensure that minimum airflow and service clearances are met.
- MTG C-C DIST = Mounting Centre to Centre Distance.
- Use M12 bolt for feet mounting.

CONDENSATE DRAIN POINTS
DN 25mm PN12

UNIT MODEL NUMBER	UNIT WEIGHT (kg)	CORNER WEIGHTS (kg)			
		A	B	C	D
PKV180T	267	48	76	65	78

MINIMUM SERVICE ACCESS CLEARANCES and AIRFLOW SPACE ALLOWANCES

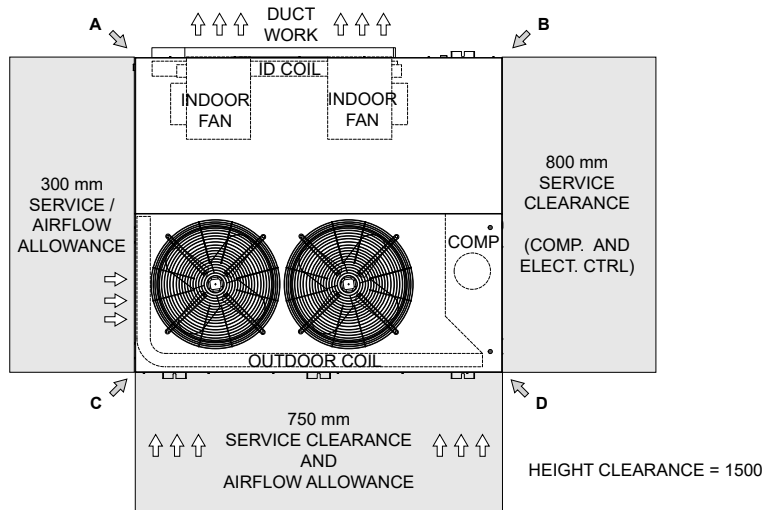

3 Phase
1 Stage
16.40 KW



Outdoor Radiated

Sound Power Level (SWL)

Fan Speed	Sound Power Level dB(A)	Octave Band Centre Frequency (Hz), dB						
		125	250	500	1k	2k	4k	8k
Low	69.3	64.9	64.0	69.2	64.5	57.6	56.3	48.0
High	72.1	72.7	71.5	71.6	66.2	61.8	57.8	48.2

Indoor Outlet

Sound Power Level (SWL)

Airflow Setting	Airflow l/s	Sound Power Level dB(A)	Octave Band Centre Frequency (Hz), dB						
			125	250	500	1k	2k	4k	8k
Nominal	850	71.9	72.4	67.7	70.5	67.5	62.0	59.0	53.3

16.40 kW
3 Phase 1 Stage

OUTDOOR RADIATED

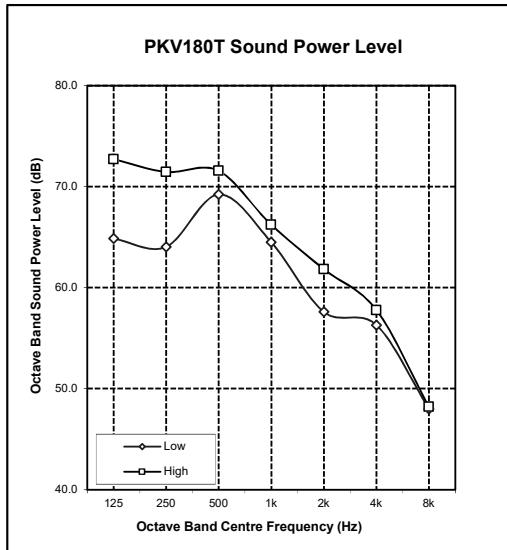

INDOOR OUTLET

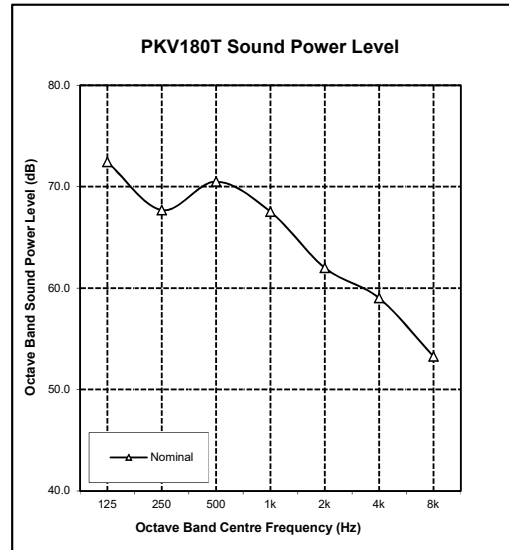

NOTES:

Radiated sound power levels are based on ISO 3743-1.

SPECIFICATIONS

PKV180T

CONSTRUCTION	
CABINET BASE	1.1 - 1.6 Galvanised Steel
CABINET TOP AND SIDES	0.9 - 1.1 mm Galvanised Steel
SURFACE FINISH	65 μ Baked Polyester Powder Coat

INSULATION	
TYPE	Foil Faced Polyethylene

ELECTRICAL	
POWER SUPPLY - 50 Hz	400 Volts x 3 Phase + N
VOLTAGE RANGE (min - max)	380 V - 440 V
FULL LOAD AMPS* - (L1 / L2 / L3)	12.1 / 14.5 / 10.7
RATED LOAD AMPS**	9.8
APPROXIMATE STARTING AMPS	< 45.0
IP RATING	IP44

IMPORTANT - The local electricity authority may require limits on starting current and voltage drop, please check prior to purchase.

* Full Load Amps are based on Compressor and Fan Motor's maximum expected current.

** Rated Load Amps are measured and tested in accordance with AS/NZS3823.1.2.

CABLE SIZE and CIRCUIT BREAKER SIZE	
Suggested minimum cable size should be used as a guide only, refer to the accordance with the latest edition of the AS/NZS 3000 "Australian/New Zealand Wiring Rules" for more details.	
CABLE SIZE (main line)	2.5 mm ² (SUGGESTED MINIMUM)
CIRCUIT BREAKER SIZE	20.0 Amps

OUTDOOR COIL	
TUBE TYPE	Copper - Rifle Bore
FIN TYPE	Aluminium - Wave
FIN SPACING (per m)	472
COIL COATING	Hydrophilic Blue Coat Coil Fin Protection

OUTDOOR FAN	
NUMBER OF FANS x TYPE	2 x Axial
NUMBER OF BLADES PER FAN	5
DIAMETER (mm)	450
OUTPUT kW (each)	0.145
MOTOR TYPE / DRIVE TYPE	6 Pole External Rotor / Direct
FAN SPEED CONTROL	3 Speed via Capacitor
The standard type outdoor fans fitted to this unit will only accept 5 Pa of external static resistance.	

INDOOR COIL	
TUBE TYPE	Copper - Rifle Bore
FIN TYPE	Aluminium - Louvre
FACE AREA (m sqr)	0.41
FIN SPACING (per m)	472
COIL COATING	Hydrophilic Blue Coat Coil Fin Protection

INDOOR FAN	
NUMBER OF FANS x TYPE	1 x Twin Deck Centrifugal EC Fan
DIAMETER (mm)	204 x 204
INPUT kW (each)	0.38
MOTOR TYPE / DRIVE TYPE	Variable Speed EC Motor / Direct
FAN SPEED CONTROL	Electronic Control

COMPRESSOR	
NUMBER PER UNIT x TYPE	Tru-Inverter Variable Speed Scroll / 1
FULL LOAD AMPS	10.7
LOCKED ROTOR AMPS	128.0
STARTING METHOD	In-built Soft Starting

REFRIGERATION SYSTEM	
REFRIGERANT TYPE	R-410A
EXPANSION CONTROL	Direct Expansion Orifice / EEV
FACTORY CHARGE (grams)	6680

PROTECTION DEVICES	
HIGH PRESSURE CUTOFF SWITCH	Nonadjustable (Automatic Reset)
LOW PRESSURE CUTOFF SWITCH	Nonadjustable (Automatic Reset)
COMPRESSOR MOTOR TEMP.	Internal Thermal Cut-Out
INDOOR FAN OVERLOAD	Internal Thermal Cut-Out
OUTDOOR FAN OVERLOAD	Internal Thermal Cut-Out
SUMP HEATER WATTS	37 W during compressor off cycle

ELECTRONIC CONTROLS	
DEFROST METHOD	Reverse Cycle
DEFROST TYPE	Adaptive Demand Defrost
CONTROL CIRCUIT BREAKER	10.0 Amps
LC7-2 FIELD CONTROL WIRING	Cat5e UTP (AWG24) Data Cable

OPERATING RANGE			
It is essential that the unit is correctly sized for the application and operates within its recommended range of operating conditions as shown below.			
MODE	RANGE	INDOOR AIR INTAKE TEMPERATURE	OUTDOOR AIR INTAKE TEMPERATURE
Cooling	Max.	30°C DB / 22°C WB	50°C DB
	Min.	20°C DB / 16°C WB	5°C DB
Heating	Max.	24°C DB	19.5°C DB / 18°C WB
	Min.	16°C DB	-15°C DB

AIR FILTERS	
All return air including fresh air must have adequate filters supplied and fitted by the installing contractor. Filters must be located in accessible location between the return air grille and the unit.	
ActronAir does not supply or make any provisions for return air filter.	

UNIT COMPLIANCE	
<ul style="list-style-type: none"> AS/NZS 3823.2 (MEPS) AS/NZS 4755.3.1 (DRM1, 2 and 3) AS/NZS CISPR 11, Group 1 Class A (EMC) 	

3 Phase
1 Stage

16.40 kW



