

ADVANCE SPLIT DUCTED UNIT

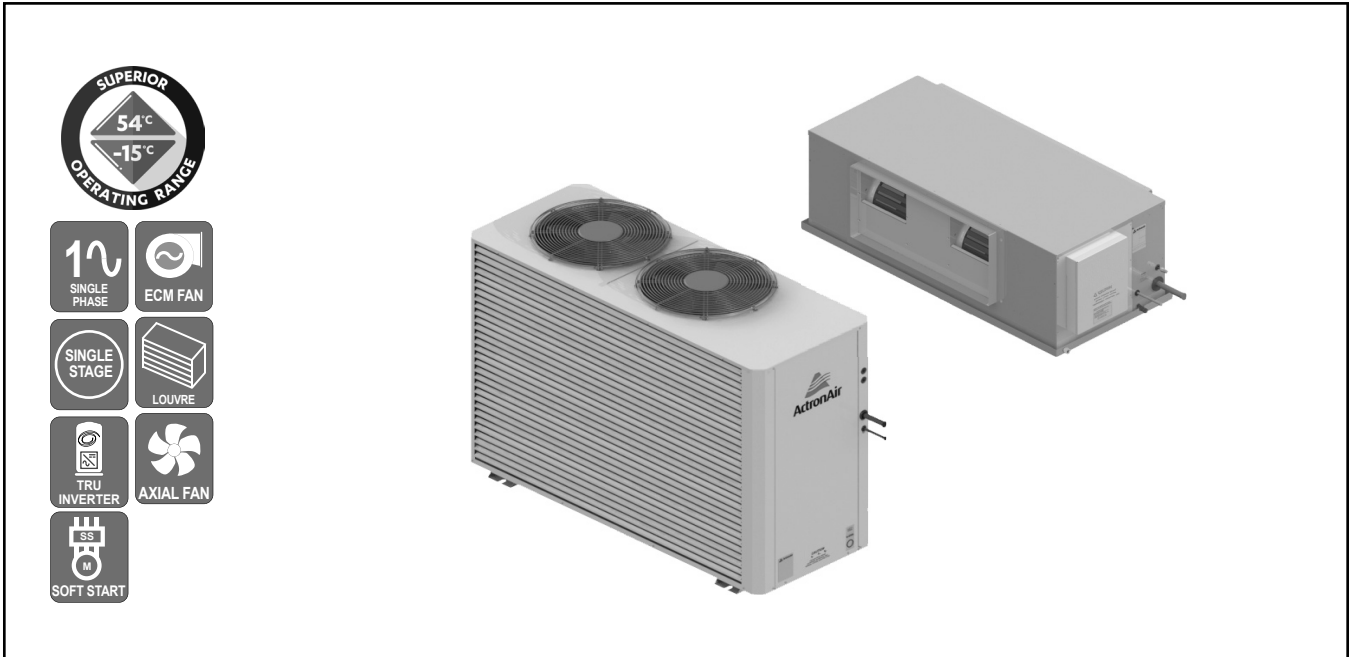

1 Phase
1 Stage
14.25 kW

UNIT FEATURES

- Tru-Inverter™ Variable Speed Compressor and Drive Technology
- 20-100% Superior Refrigeration Operating Capacity Range
- ECM High Efficiency Indoor Fan Motor
- Three Speed Outdoor Fans
- Adaptive Demand Defrost
- Active Power Factor Correction
- 20m Cat5e wall controller cable included
- Low ambient cooling operation to +5 degree
- Fault and Run Indication - Relay Output
- Up to 3 Wall Controllers and 3 Remote Temperature Sensors
- Ready for up to 8 zones
- Compressor Soft Start via Variable Speed Drive Control
- Hydrophilic Blue Fin Coil Coat Protection - Indoor and Outdoor Coils
- Integrated Fan Coil Safety Tray with Drain Kit
- Pre-charged with R-410A Refrigerant
- Bi-Flow Electronic Expansion Valve
- Powder Coated Outdoor Unit with Louvred Coil Guard
- Variable Fan Technology
- Turbo Mode

CONTROL OPTIONS AND FEATURES

ActronAir LR7-1/LC7-2

- Available in White or Grey
- 7-day Programmable Controller with 2 Events per Day
- 24-hour ON/OFF Timer
- Temperature Setback
- After Hours Time (LC7-2 Only)
- Auto, Heat, Cool, Turbo, Fan Modes and Night Mode Functions
- Fixed, Auto and Continuous Indoor Fan Operation
- Optional 2nd and 3rd Controllers with Mimic Logic
- On-board Temperature Sensor

ActronAir NEO

- 7" Colour Touch Screen Master Controller
- In-built Wi-Fi and Blue-Tooth
- Neo Connect App
- On-Board Temperature, Humidity and Proximity Sensor
- Optional wireless Zone Controller with on-board sensor
- Optional wireless Zone Sensor
- Available in White or Black

ActronAir Group Control

ActronAir BMS ICUNO-MOD (Modbus 485)

THIRD PARTY CONTROL OPTIONS

- Manual and Analogue Inputs

PLENUMS (Optional)

- Supply Air Plenums are available in 2 or 3 way Configuration (See Accessories Sec. for details of spigots availability)
- Return Air Plenums are available with 2 x 350 mm or 2 x 400 mm Spigots

SPECIFICATION SUMMARY

OUTDOOR UNIT MODEL	CRV160S		
INDOOR UNIT MODEL	EVV160S		
		(1) TOTAL	(2) NETT
(3) COOLING CAPACITY (kW)	MINIMUM	3.55	3.50
	RATED	14.25	14.00
	TRUMAX (9)	16.33	16.00
(4) HEATING CAPACITY (kW)	MINIMUM	3.15	3.20
	RATED	14.75	15.00
	TRUMAX (9)	16.67	17.00
(3) SENSIBLE CAPACITY (kW)	RATED	12.01	11.76
(5) COOLING INPUT POWER (kW)	RATED	4.29	
(5) HEATING INPUT POWER (kW)	RATED	4.22	
EER	RATED	3.32	3.26
COP	RATED	3.50	3.55
(6) INDOOR AIRFLOW (l/s) - MIN. / NOMINAL / MAX.	250 / 750 / 900		
OUTDOOR SOUND PRESS. LEVEL @ 3M dB(A) - LOW / HIGH	48.7 / 52.8		
OUTDOOR SOUND POWER LEVEL dB(A) - LOW / HIGH	65.8 / 71.0		
POWER SUPPLY - OUTDOOR	230V / 1Ph+N / 50Hz		
POWER SUPPLY - INDOOR	230V / 1Ph+N / 50Hz		
(2) RATED LOAD AMPS -- OUTDOOR / INDOOR / TOTAL	17.7 / 2.2 / 19.9		
(7) FULL LOAD AMPS -- OUTDOOR / INDOOR / TOTAL	24.6 / 3.0 / 27.6		
(8) CIRCUIT BREAKER AND CABLE AMPS	32.0		
APPROXIMATE STARTING AMPS	< 45		
POWER FACTOR	0.99		
WEIGHT (kg) -- INDOOR / OUTDOOR	56 / 144		

(1) Based on unit rating excluding indoor fan kW.
 (2) Measured and tested in accordance with AS/NZS 3823.1.2.
 (3) At 27°C DB / 19°C WB entering air temperatures and 35°C ambient.
 (4) At 20°C DB entering air temperature and 7°C DB / 6°C WB ambient.
 (5) Total input power excludes indoor fan kW. Nett input power includes indoor fan kW.
 (6) Max. - Min. airflow application range.
 (7) Full Load Amps are based on compressor and fan motors' maximum expected current.
 (8) See Specifications sheet for cable size and circuit breaker size details.
 (9) TRUMAX - Maximum Capacity.

Note: Use nett input power to estimate running cost.

UNIT OPTIONS

- Additional Full Coil Coat Protection
- Split Fan Coil Unit
- Vertical Fan Coil Unit
- Horizontal Discharge Condenser
- Outdoor Drain Tray



CAPACITY SELECTION DATA

CRV160S / EVV160S

COOLING PERFORMANCE

AIR ENTERING		TOTAL CAPACITY kW	TOTAL SENSIBLE CAPACITY - kW											
OUTDOOR DB - °C	INDOOR WB - °C		AT DB TEMPERATURE ONTO INDOOR COIL - °C											
			20	21	22	23	24	25	26	27	28	29	30	
25	16	14.48	9.47	10.04	10.62	11.19	11.77	12.38						
	17	14.95	9.12	9.57	10.03	10.83	11.64	12.13	12.62	13.11				
	18	15.41	8.77	9.10	9.43	10.47	11.51	11.88	12.25	13.03	13.80			
	19	15.91	8.60	8.86	9.13	9.79	10.44	11.38	12.32	12.50	12.67	12.93		
	20	16.42	8.42	8.74	9.10	9.35	9.60	10.51	11.42	12.15	12.88	12.96	13.04	
	21	16.80		8.62	9.08	9.29	9.51	10.15	10.79	11.51	12.11	12.56	13.00	
22	17.18			9.06	9.24	9.41	9.79	10.16	10.86	11.35	12.16	12.97		
30	16	13.99	9.17	9.79	10.42	11.01	11.61	12.08						
	17	14.47	8.62	9.19	9.77	10.59	11.40	11.85	12.29	12.74				
	18	14.95	8.06	8.59	9.13	10.16	11.20	11.62	12.04	12.43	12.82			
	19	15.26	8.04	8.39	8.75	9.46	10.16	11.16	12.15	12.22	12.30	12.74		
	20	15.70	8.01	8.29	8.70	8.98	9.27	10.20	11.13	11.89	12.40	12.64	12.89	
	21	15.99		8.19	8.67	8.97	9.26	9.90	10.53	11.15	11.73	12.28	12.83	
22	16.28			8.64	8.95	9.26	9.59	9.93	10.42	11.06	11.91	12.77		
35	16	13.80	8.72	9.37	10.02	10.77	11.53	12.01						
	17	13.78	8.15	8.77	9.39	10.28	11.18	11.71	12.23	12.75				
	18	13.76	7.58	8.17	8.76	9.80	10.84	11.40	11.97	12.13	12.29			
	19	14.25	7.36	7.90	8.43	9.11	9.79	10.80	11.81	12.01	12.21	12.68		
	20	14.77	7.15	7.76	8.02	8.39	8.77	9.77	10.77	11.56	12.27	12.45	12.76	
	21	15.14		7.63	7.81	8.26	8.70	9.36	10.02	10.80	11.50	12.05	12.68	
22	15.50			7.60	8.12	8.64	8.96	9.28	10.04	10.73	11.66	12.59		
40	16	12.54	8.51	9.18	9.85	10.55	11.26	11.79						
	17	12.98	7.78	8.48	9.18	10.05	10.92	11.46	12.01	12.55				
	18	13.41	7.06	7.78	8.51	9.54	10.58	11.13	11.68	11.99	12.30			
	19	13.66	7.02	7.26	7.49	8.50	9.50	10.47	11.43	11.56	12.09	12.62		
	20	14.16	6.99	6.99	7.06	7.75	8.45	9.52	10.59	11.13	12.37	12.50	12.71	
	21	14.56		6.73	6.84	7.52	8.20	8.94	9.69	10.39	11.42	11.97	12.56	
22	14.95			6.62	7.28	7.95	8.36	8.78	9.64	10.46	11.44	12.42		
45	16	11.91	8.22	8.82	9.43	10.20	10.98	11.48						
	17	12.25	7.80	8.27	8.74	9.69	10.64	11.17	11.70	12.24				
	18	12.60	7.38	7.71	8.05	9.17	10.29	10.86	11.43	11.86	12.29			
	19	12.87	6.92	7.18	7.44	8.34	9.23	10.24	11.25	11.63	12.07	12.51		
	20	13.25	6.46	6.91	6.95	7.55	8.15	9.18	10.22	11.18	12.14	12.35	12.57	
	21	13.58		6.64	6.70	7.33	7.97	8.61	9.25	10.17	11.14	11.76	12.38	
22	13.92			6.45	7.12	7.79	8.04	8.29	9.17	10.14	11.16	12.19		
50	16	11.21	7.92	8.27	8.62	9.67	10.72	11.37						
	17	11.58	7.24	7.75	8.27	9.32	10.38	11.02	11.67	12.31				
	18	11.96	6.55	7.23	7.91	8.98	10.04	10.68	11.33	11.56	11.80			
	19	12.16	6.40	6.60	6.81	7.89	8.98	10.00	11.02	11.31	11.60	11.89		
	20	12.50	6.26	6.29	6.46	7.20	7.94	8.96	9.99	10.80	11.62	11.74	11.87	
	21	12.88		5.98	6.28	7.00	7.71	8.35	8.98	9.62	10.77	11.34	11.90	
22	13.26			6.11	6.80	7.49	7.73	7.98	8.44	9.93	10.93	11.94		

14.25 kW
1 Phase 1 Stage

HEATING PERFORMANCE

WB TEMP ON OD COIL - °C	HEATING CAPACITY - kW									
	AT DB ENTERING INDOOR - °C									
	16		18		20		22		24	
	TH	IH	TH	IH	TH	IH	TH	IH	TH	IH
-10	9.36	8.98	9.32	8.95	9.28	8.91	9.23	8.86	9.19	8.82
-8	9.97	9.47	9.92	9.42	9.87	9.37	9.82	9.32	9.76	9.27
-6	10.60	9.96	10.54	9.90	10.48	9.85	10.46	9.83	10.40	9.78
-4	11.27	10.37	11.19	10.29	11.16	10.27	11.10	10.21	11.03	10.15
-2	12.00	10.68	11.92	10.61	11.84	10.54	11.77	10.47	11.70	10.41
0	12.71	11.18	12.62	11.10	12.56	11.06	12.47	10.98	12.39	10.91
2	13.41	12.21	13.31	12.11	13.21	12.02	13.11	11.93	13.02	11.85
4	14.19	14.19	14.04	14.04	13.96	13.96	13.87	13.87	13.77	13.77
6	15.00	15.00	14.87	14.87	14.75	14.75	14.63	14.63	14.54	14.54
8	15.84	15.84	15.69	15.69	15.56	15.56	15.44	15.44	15.33	15.33
10	16.70	16.70	16.56	16.56	16.41	16.41	16.28	16.28	16.15	16.15
12	17.60	17.60	17.45	17.45	17.29	17.29	17.13	17.13	16.99	16.99
14	18.53	18.53	18.36	18.36	18.19	18.19	18.02	18.02	17.87	17.87
16	19.50	19.50	19.30	19.30	19.12	19.12	18.94	18.94	18.76	18.76
18	20.50	20.50	20.29	20.29	20.08	20.08	19.87	19.87	19.67	19.67

TH - Total Heating Capacity (kW).
IH - Integrated Heating Capacity (kW)
Includes defrost losses.

AIRFLOW CORRECTION MULTIPLIER

% VARIATION	-20%	-15%	-10%	-5%	Nominal	+5%	+10%	+15%	+20%
INDOOR AIRFLOW (l/s)	600	638	675	713	750	788	825	863	900
TOTAL COOLING	0.965	0.982	0.989	0.997	1.000	1.004	1.009	1.015	1.020
SENSIBLE COOLING	0.884	0.916	0.945	0.974	1.000	1.024	1.046	1.072	1.092
HEATING FACTOR	0.969	0.976	0.983	0.991	1.000	1.011	1.022	1.033	1.044

NOTES:

- No allowance has been made for the effect of indoor fan motor.
- Selection tables are based on nominal airflows. Correction factors must be applied for selection away from these conditions.

PIPE LENGTH CORRECTION MULTIPLIER

	5m	10m	20m	30m	40m	50m	60m
COOLING	1.000	0.992	0.975	0.959	0.943	0.927	0.912
HEATING	1.000	1.000	1.000	1.000	1.000	1.000	1.000

Correction multipliers are based on horizontal pipe runs.



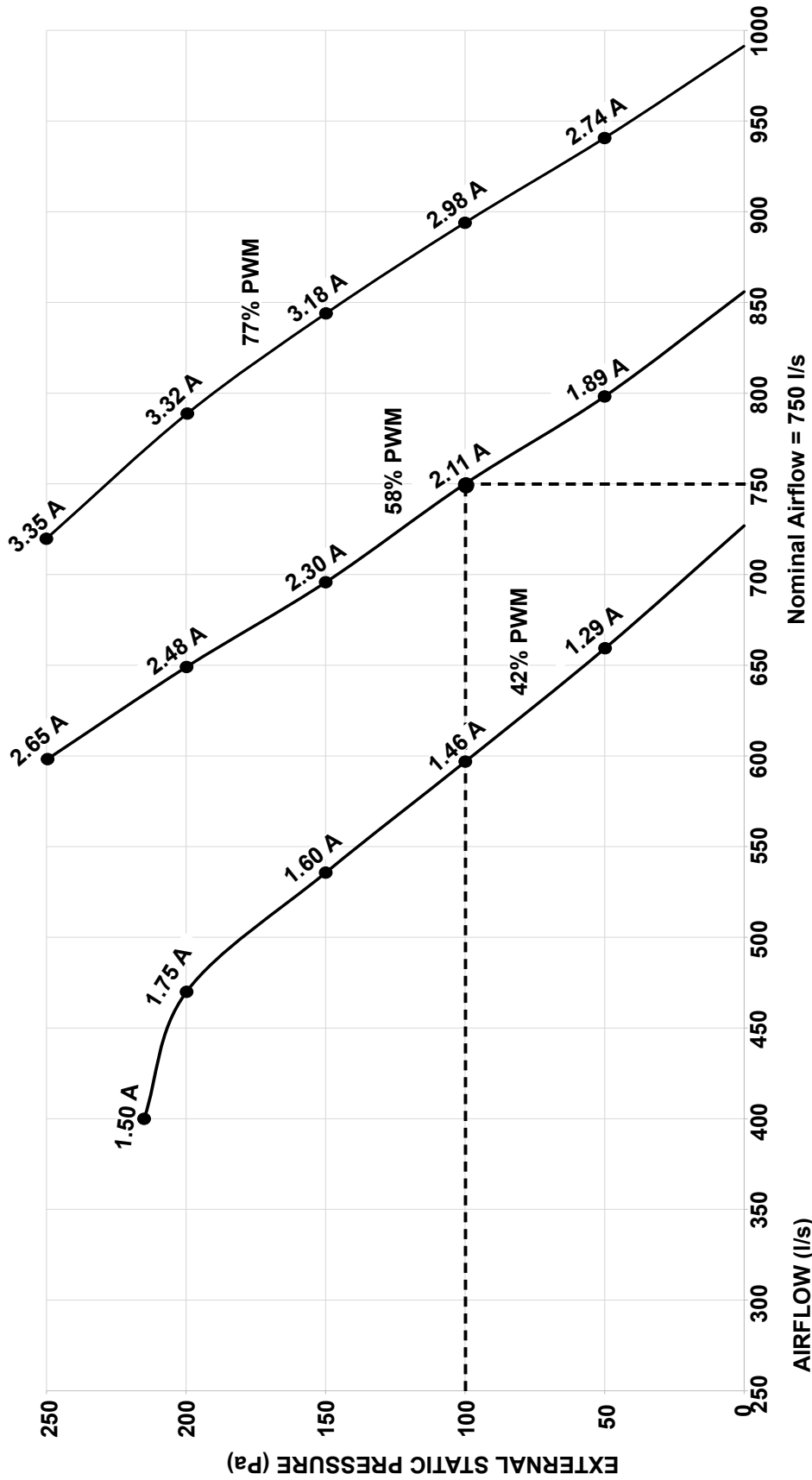

Variable Fan Technology Airflow Range
 Hi-Mid-Low Speed Airflow Range

14.25 kW
 1 Phase 1 Stage



14.25 kW
1 Phase 1 Stage

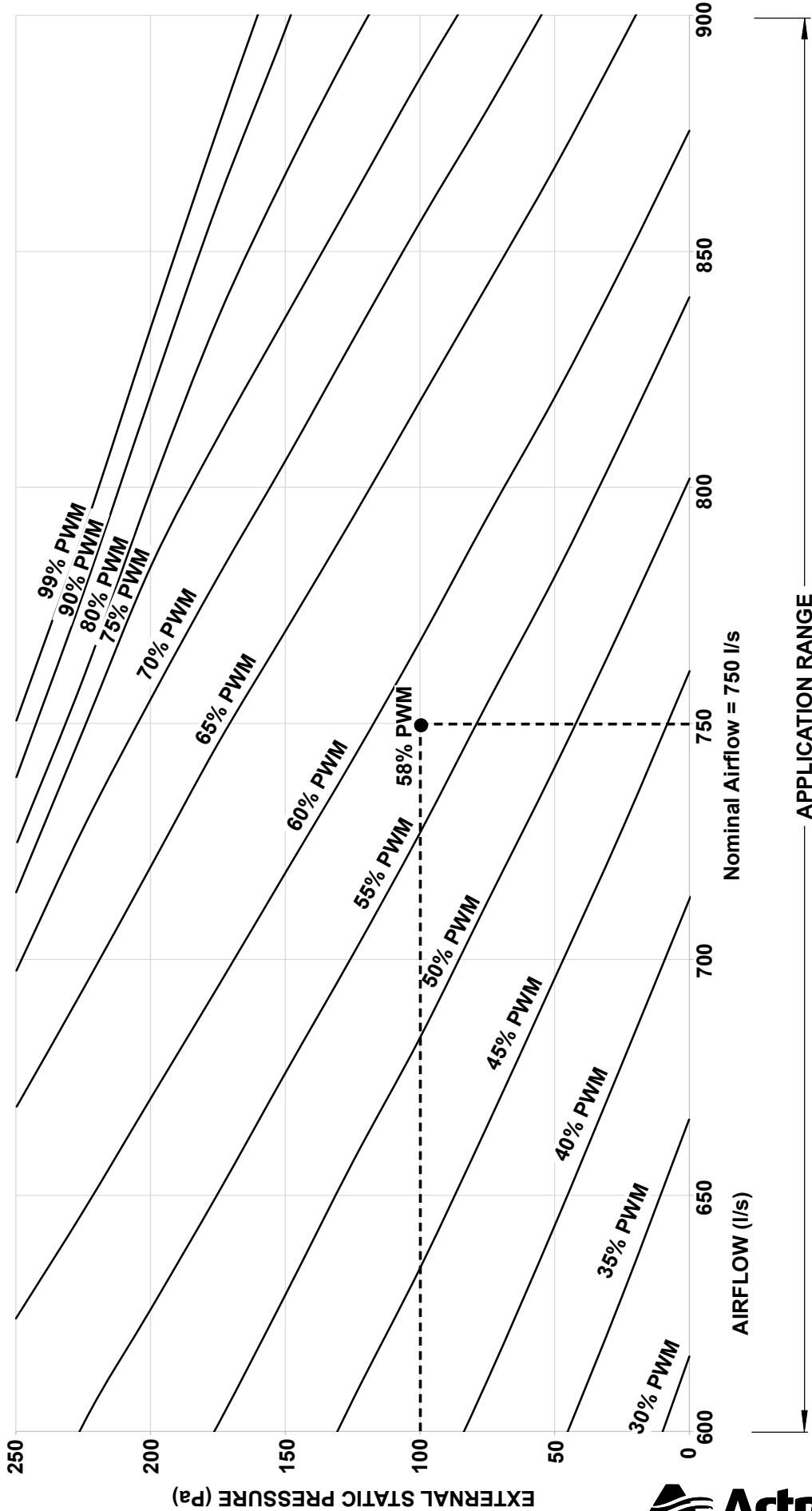

APPLICATION RANGE

Nominal Airflow = 750 l/s



OUTDOOR UNIT DIMENSIONS

CRV160S

C OUTDOOR UNIT - STANDARD MODEL

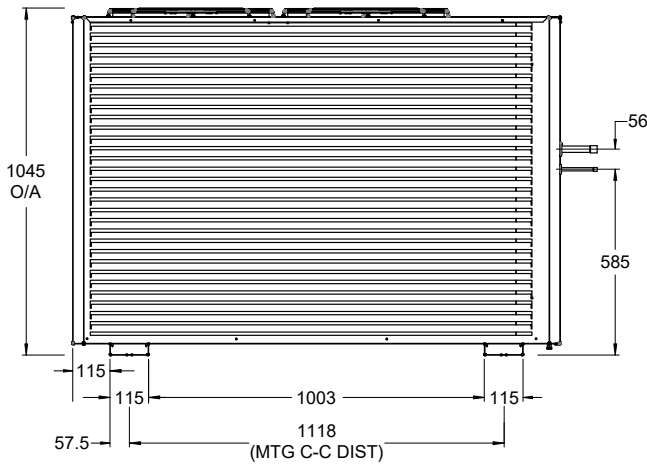
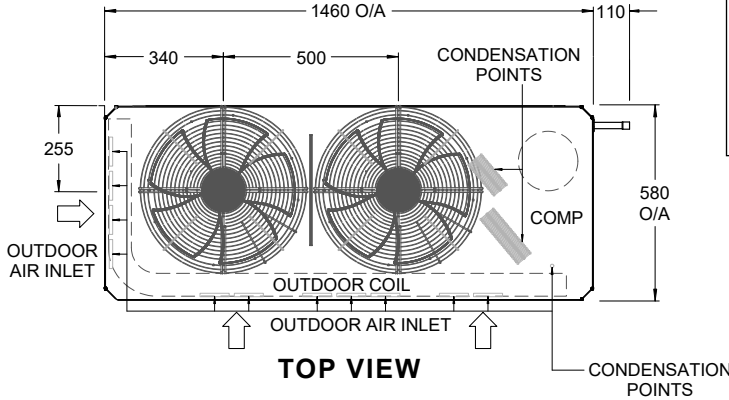

CONDENSATION POINTS ARE DESIGNED TO ENSURE ALL CONDENSATION IS REMOVED EFFICIENTLY TO AVOID WATER POOLING WITHIN THE CONDENSER. IF A SINGLE CONDENSATION DRAIN POINT IS REQUIRED, ACTRONAIR RECOMMENDS THE INSTALLATION OF A CONDENSER TRAY. THESE ARE AVAILABLE AS AN ADDITIONAL ACCESSORY.

** DRAWING IS SUBJECT TO CHANGE WITHOUT NOTICE**

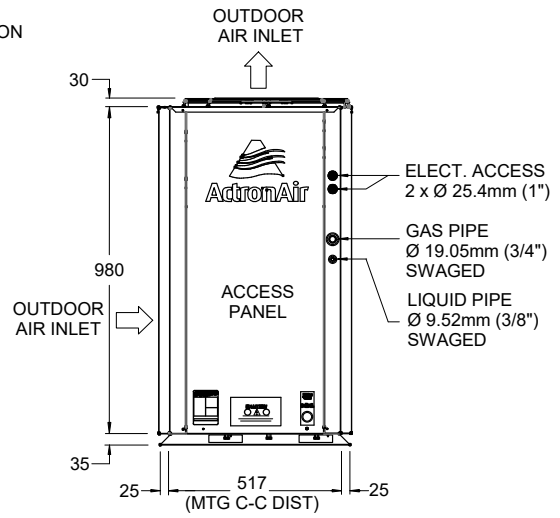

1 Phase
1 Stage
14.25 kW

SIDE VIEW

FRONT VIEW

UNIT MODEL NUMBER	UNIT WEIGHT (kg)	CORNER WEIGHTS (kg)			
		A	B	C	D
CRV160S	144	22	36	34	52

MINIMUM SERVICE ACCESS AREAS AND AIRFLOW CLEARANCES

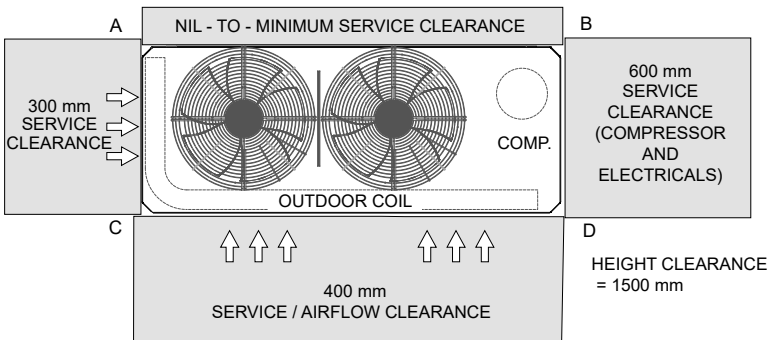

NOTES:

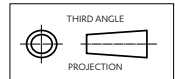

- Do not scale drawing. All dimensions are in mm unless specified. Refer to corresponding unit dimensional drawing for mounting hole details.
- Service Access Areas and Spaces for Airflow Clearances given are suggested minimum based on the condition that the spaces around the units are free from any obstructions and a walkway passage of 1000 mm between the units or between the unit and the outside perimeter is available.
- Minimum service access areas and spaces for airflow clearances are responsibilities of the installer, ActronAir will not be held liable for any extra charges incurred due to lack of access and space for airflow.
- Under all circumstances, condenser air must not recirculate back onto condenser coil. Keep all clearance free of any obstructions.
- Maximum External Static of Outdoor Fans is 5 Pa.
- STACKING OF UNITS: Ensure that minimum airflow and clearances are met.
- Refer to pipe Connection Details on Specifications Sheet.
- MTG C-C DIST = Mounting Centre to Centre Distance.
- Use M12 bolt for feet mounting.



E INDOOR UNIT - STANDARD MODEL

OVERALL NOMINAL DIMENSION (H x W x D)
 = 412 x 1290 x 615
 SUPPLY DUCT (H x W) = 300 x 715
 RETURN DUCT = 340 x 1100
 DRAIN CONNECTION = 20 mm OD

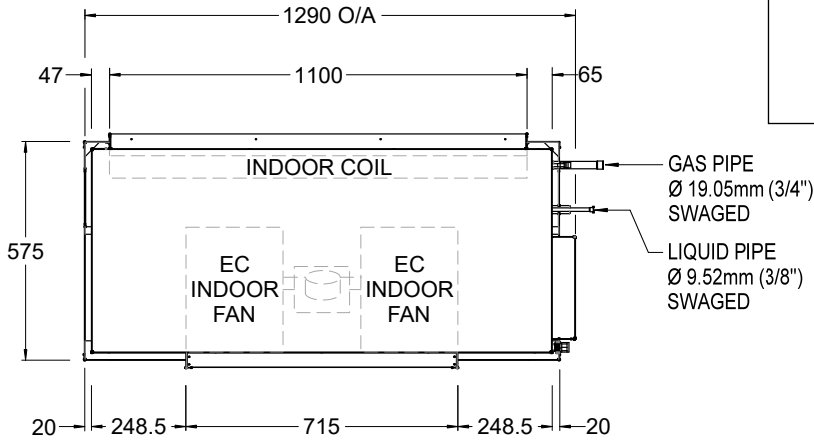

TOP VIEW

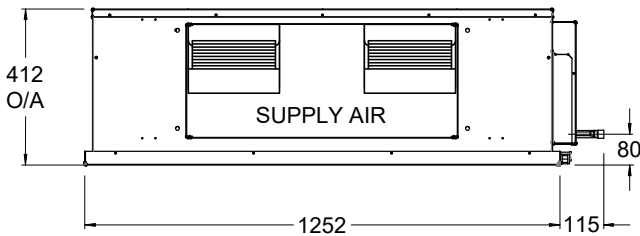

FRONT VIEW

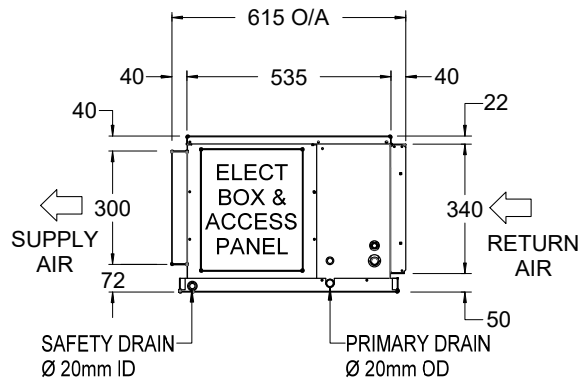

SIDE VIEW

UNIT MODEL NUMBER	UNIT WEIGHT
EVV160S	56

NOTES:

1. Do not scale drawing. All dimensions are in mm unless specified. Refer to corresponding unit dimensional drawing for mounting hole details.
2. Service Access Areas and Spaces for Airflow Clearances given are suggested minimum based on the condition that the spaces around the units are free from any obstructions and a walkway passage of 1000 mm between the units or between the unit and the outside perimeter is available.
3. Minimum Service Access Areas and Spaces for Airflow Clearances are responsibilities of the installer, ActronAir will not be held liable for any extra charges incurred due to lack of access and space for airflow.

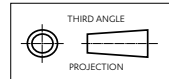

MINIMUM SERVICE ACCESS AREAS AND AIRFLOW CLEARANCES

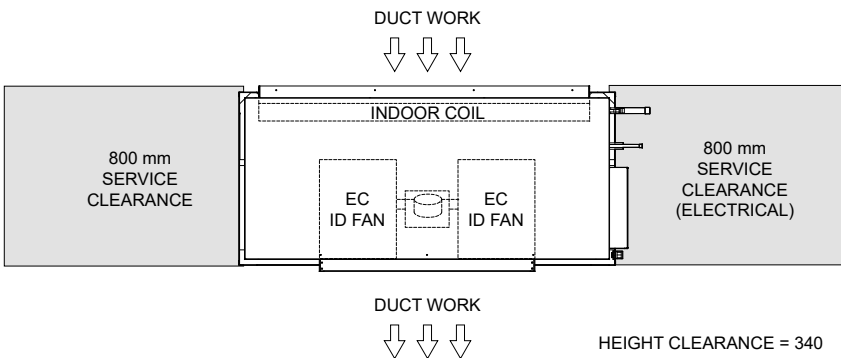

14.25 kW
1 Phase 1 Stage

Outdoor Radiated

Sound Power Level (SWL)

Fan Speed	Sound Power Level dB(A)	125	250	500	1k	2k	4k	8k
		Low	62.9	62.8	60.5	61.9	59.6	52.5
Medium	67.0	69.7	64.3	63.2	62.2	59.7	52.9	42.6
High	71.0	73.2	69.3	68.2	65.7	62.8	57.5	46.6

Indoor Outlet

Sound Power Level (SWL)

Airflow Setting	Airflow l/s	Sound Power Level dB(A)	125	250	500	1k	2k	4k	8k
			Nominal	750	70.0	70.9	69.3	68.5	63.7

1 Phase
1 Stage
14.25 kW

OUTDOOR RADIATED

INDOOR OUTLET

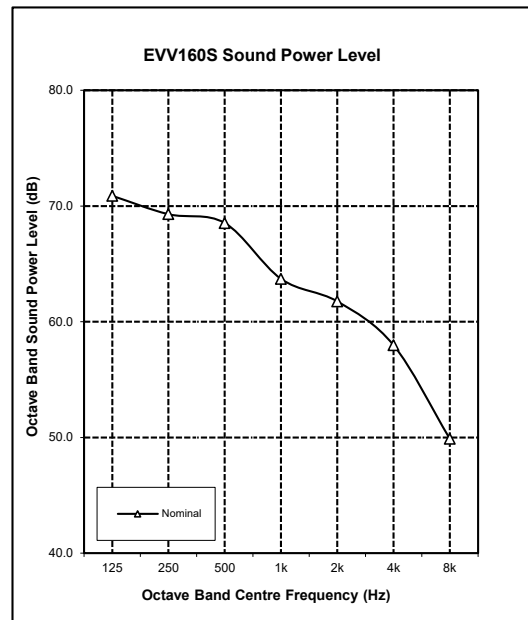
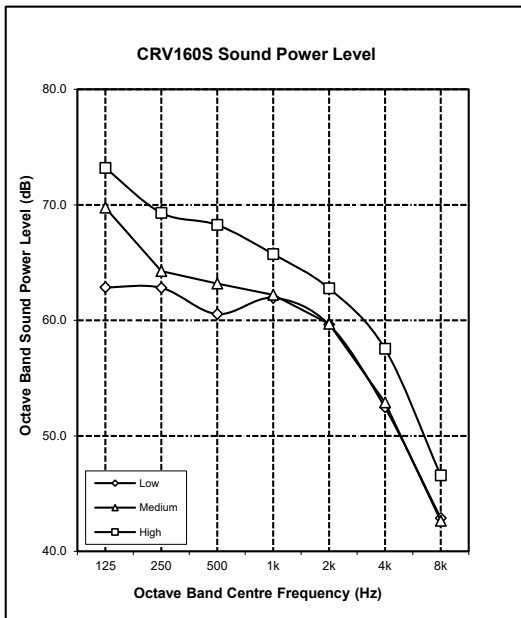

NOTE:

Radiated sound power levels are based on ISO 3743-1.



SPECIFICATIONS

CRV160S / EVV160S

14.25 kW
1 Phase 1 Stage

CONSTRUCTION

CABINET (Indoor Unit)	0.5 - 0.9 mm Galvanised Steel
CABINET (Outdoor Unit)	0.9 - 1.2 mm Galv. Steel
SURFACE FINISH (Outdoor Unit)	65 µ Baked Polyester Powder Coat

INSULATION

TYPE - (Indoor Unit)	Foil Faced Polyethylene Expanded Polystyrene
----------------------	---

SOUND LEVEL * dB(A)

SOUND PRESS. - Low / High	48.7/52.8
SOUND POWER LEVEL - Low / High	65.8/71.0

* Sound data are based on outdoor fan's manufacturer sound level data.

ELECTRICAL

OUTDOOR UNIT

Power Supply - 50 Hz	230 Volts x 1 Phase + N
Voltage Range (min - max)	216 V - 253 V
Full Load Amps*	24.6
Rated Load Amps**	17.7
Approximate Starting Amps	< 45.0
IP Rating	IP44

INDOOR UNIT

Power Supply - 50 Hz	230 Volts x 1 Phase + N
Voltage Range (min - max)	216 V - 253 V
Full Load Amps*	3.0
IP Rating	IP20

OUTDOOR & INDOOR UNIT (TOTAL)

Full Load Amps* - Phase 1	27.6
Full Load Amps* - Phase 2 & 3	N/A
Rated Load Amps**	19.9

IMPORTANT - The local electricity authority may require limits on starting current and voltage drop, please check prior to purchase.

* Full Load Amps are based on Compressor and Fan Motor's maximum expected current.

** Rated Load Amps are measured and tested in accordance with AS/NZS3823.1.2.

CABLE SIZE & CIRCUIT BREAKER SIZE

Suggested minimum cable size should be used as a guide only, refer to AS/NZS 3000 "Australian/New Zealand Wiring Rules" for more details.

Cable Size (main line)	6.0 mm ² (SUGGESTED MINIMUM)
Cable Size (indoor to outdoor wire)	1.0 mm ² (SUGGESTED MINIMUM)
Circuit Breaker Size	32.0 Amps
Data Cable Field Wiring (Outdoor-to-Indoor)	2 Core 7 / 0.30 (0.5mm ²) Twisted Shielded Data Cable

OUTDOOR COIL

TUBE TYPE	Copper - Rifle Bore
FIN TYPE	Aluminium - Wave
FACE AREA (m sqr)	1.65
FIN SPACING (per m)	472
COIL COATING	Hydrophilic Blue Fin Coil Coat Protection

OUTDOOR FAN

NUMBER OF FANS x TYPE	2 x Axial
NUMBER OF BLADES PER FAN	5
DIAMETER (mm)	450
OUTPUT kW (each)	0.16
MOTOR TYPE / DRIVE TYPE	6 Pole External Rotor / Direct
FAN SPEED CONTROL	3 Speed via Capacitor

The standard type outdoor fans fitted to this unit will only accept 5Pa of external static resistance.

INDOOR COIL

TUBE TYPE	Copper - Rifle Bore
FIN TYPE	Aluminium - Wave
FACE AREA (m sqr)	0.41
FIN SPACING (per m)	472
COIL COATING	Hydrophilic Blue Fin Coil Coat Protection

INDOOR FAN

NUMBER OF FANS x TYPE	1 x Twin Deck Centrifugal EC Fan
DIAMETER (mm) x WIDTH (mm)	240 x 180
INPUT kW (each)	0.25
MOTOR TYPE / DRIVE TYPE	Variable Speed EC Motor / Direct
FAN SPEED CONTROL	Electronic Control

COMPRESSOR

NUMBER PER UNIT x TYPE	1 x Variable Speed Scroll (Hermetic)
FULL LOAD AMPS	24.3
STARTING METHOD	Soft Start via Variable Speed Drive

REFRIGERATION SYSTEM

REFRIGERANT TYPE	R-410A
EXPANSION CONTROL	Direct Expansion Orifice / EEV
FACTORY CHARGE (grams)	6300
PRE-CHARGE LENGTH (metres)	15
ADDITIONAL REF. CHARGE (gm/m)	50

FILTER DRIER

CONNECTION SIZE & TYPE	9.52 mm (3/8") ODF Soldered Bi-Flow
FACTORY SUPPLIED / FITTED	No

INTERCONNECTING PIPE RUN

MAX PIPE LENGTH (metres)	60
MAX. VERTICAL LENGTH (metres)	20 (Included in Max. Pipe Length)
FIELD PIPE SIZES	
Liquid Pipe	9.52 mm (3/8")
Gas Pipe	19.05 mm (3/4")

PIPE CONNECTIONS

Indoor	Liquid Pipe	9.52 mm (3/8") Swaged to fit 9.52 mm (3/8") field pipe
	Gas Pipe	19.05 mm (3/4") Swaged to fit 19.05 mm (3/4") field pipe
Outdoor	Liquid Pipe	9.52 mm (3/8") Swaged to fit 9.52 mm (3/8") field pipe
	Gas Pipe	19.05 mm (3/4") Swaged to fit 19.05 mm (3/4") field pipe

CONNECTION TYPE

Insulate both gas and liquid pipes separately.
--

PROTECTION DEVICES

HIGH PRESSURE CUTOUT SWITCH	Nonadjustable (Automatic Reset)
LOW PRESSURE CUTOUT SWITCH	Nonadjustable (Automatic Reset)
COMPRESSOR MOTOR TEMP.	Internal Thermal Cut-Out
INDOOR FAN OVERLOAD	Internal Thermal Cut-Out
OUTDOOR FAN OVERLOAD	Internal Thermal Cut-Out
SUMP HEATER WATTS*	37W during compressor off cycle

*Crankcase Heater is to be disconnected for pipe lengths 8m or less.

ELECTRONIC CONTROLS

DEFROST METHOD	Reverse Cycle
DEFROST TYPE	Adaptive Demand Defrost
CONTROL CIRCUIT BREAKER	10.0 Amps
MASTER/SECONDARY CONTROLLER CABLE SPECS.	Cat5e with RJ45 Connectors and cable boots.

OPERATING RANGE

It is essential that the unit is correctly sized for the application and operates within its recommended range of operating conditions as shown below.

MODE	RANGE	INDOOR AIR INTAKE TEMPERATURE	OUTDOOR AIR INTAKE TEMPERATURE
Cooling	Max.	30°C DB / 22°C WB	54°C DB
	Min.	20°C DB / 16°C WB	5°C DB
Heating	Max.	24°C DB	19.5°C DB / 18°C WB
	Min.	16°C DB	-15°C DB

AIR FILTERS

All return air including fresh air must have adequate filters supplied and fitted by the installing contractor. Filters must be located in accessible location between the return air grille and the unit.
ActronAir does not supply or make any provisions for return air filter.

UNIT COMPLIANCE

- AS/NZS 3823.2 (MEPS)
- AS/NZS 4755.3.1 (DRM 1, 2 and 3)
- AS/NZS CISPR 14.1 (EMC)
- AS/NZS 60335.1 (ELECTRICAL APPLIANCE SAFETY)
- AS/NZS 60335.2.40 (ELECTRICAL APPLIANCE SAFETY - AIR CONDITIONERS)



WIRING DIAGRAM

CRV160S / EVV160S

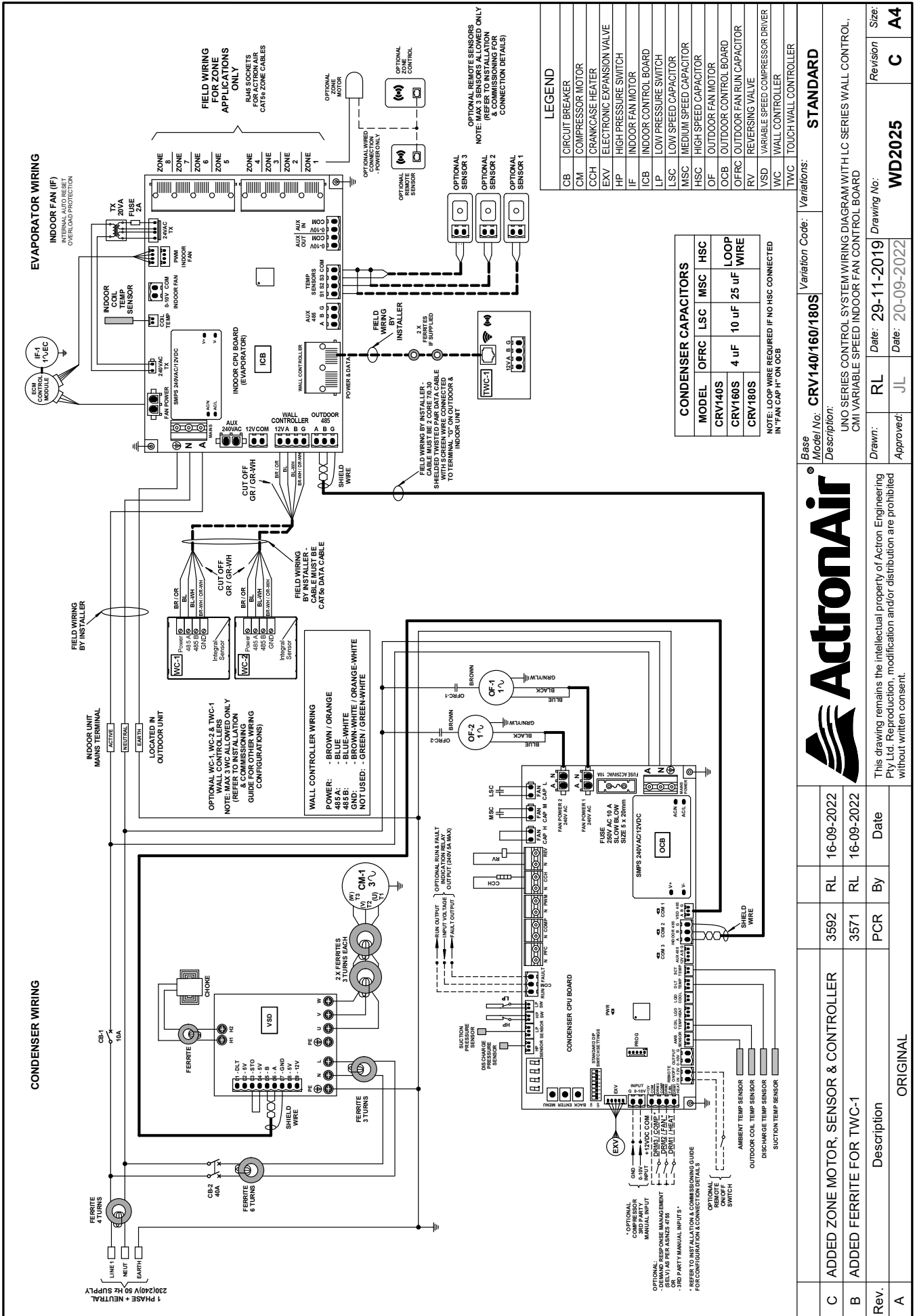

Base Model No:	CRV140/160/180S	Variation Code:	STANDARD
Description:	LINO SERIES CONTROL SYSTEM WIRING DIAGRAM WITH LC SERIES WALL CONTROL, CMI VARIABLE SPEED INDOOR FAN CONTROL BOARD		
Drawn:	RL	Date:	29-11-2019
Approved:	JL	Date:	20-09-2022
Revision:	C	Drawing No:	WD2025
Size:	A4		

1 Phase
1 Stage
14.25 kW

Rev.	Description	By	Date
C	ADDED ZONE MOTOR, SENSOR & CONTROLLER	RL	16-09-2022
B	ADDED FERRITE FOR WTC-1	RL	16-09-2022
A		PCR	

ORIGINAL

H OUTDOOR UNIT - HORIZONTAL DISCHARGE FANS

14.25 kW
1 Phase 1 Stage

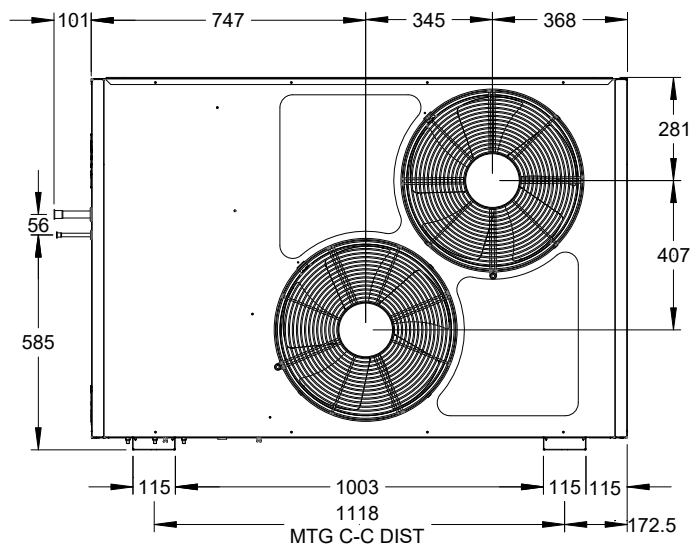
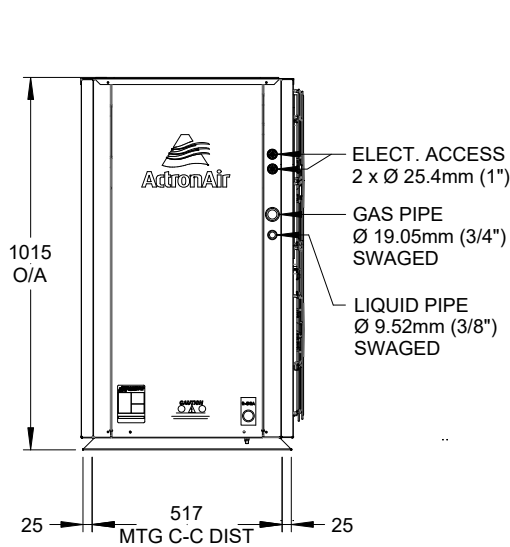
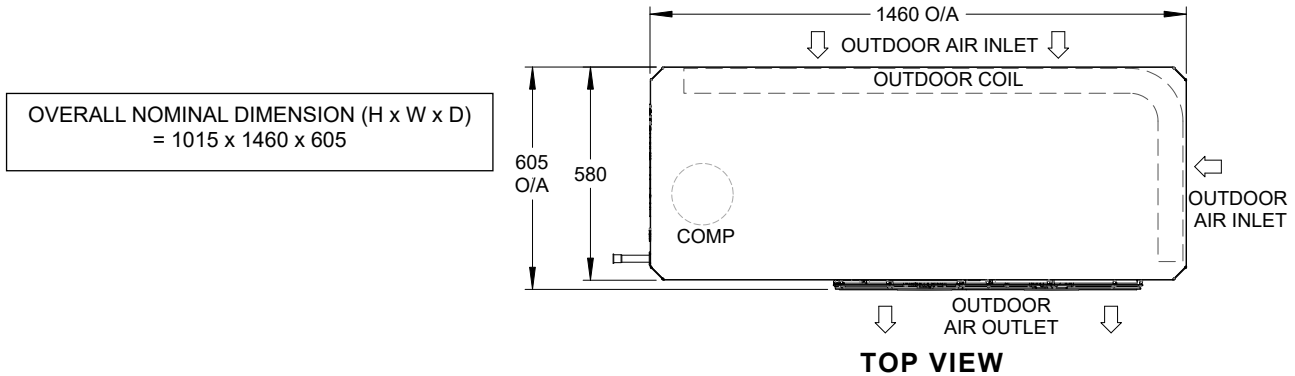

MINIMUM SERVICE ACCESS CLEARANCES & AIRFLOW SPACE ALLOWANCES

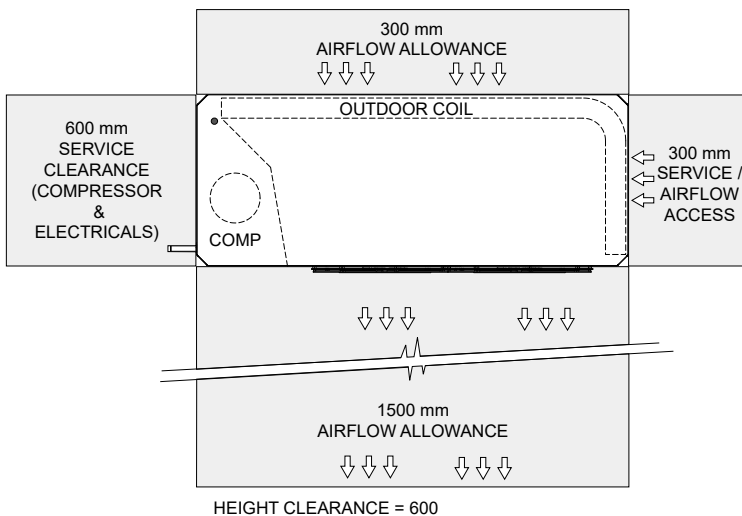

TOP VIEW

NOTES:

1. Do not scale drawing. All dimensions are in mm unless specified. Refer to corresponding unit dimensional drawing for mounting hole details.
2. Service Access Areas and Spaces for Airflow Clearances given are suggested minimum based on the condition that the spaces around the units are free from any obstructions and a walkway passage of 1000 mm between the units or between the unit and the outside perimeter is available.
3. Minimum service access areas and spaces for airflow clearances are responsibilities of the installer, ActronAir will not be held liable for any extra charges incurred due to lack of access and space for airflow.
4. Under all circumstances, condenser air must not recirculate back onto condenser coil. Keep all clearance free of any obstructions.
5. Maximum External Static of Outdoor Fans is 5 Pa.
6. STACKING OF UNITS: Ensure that minimum airflow and clearances are met.
7. Refer to pipe Connection Details on Specifications Sheet.
8. MTG C-C DIST = Mounting Centre to Centre Distance.
9. Use M12 bolt for feet mounting.

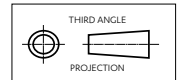

V INDOOR UNIT - UPRIGHT FAN COIL WITH VERTICAL DISCHARGE

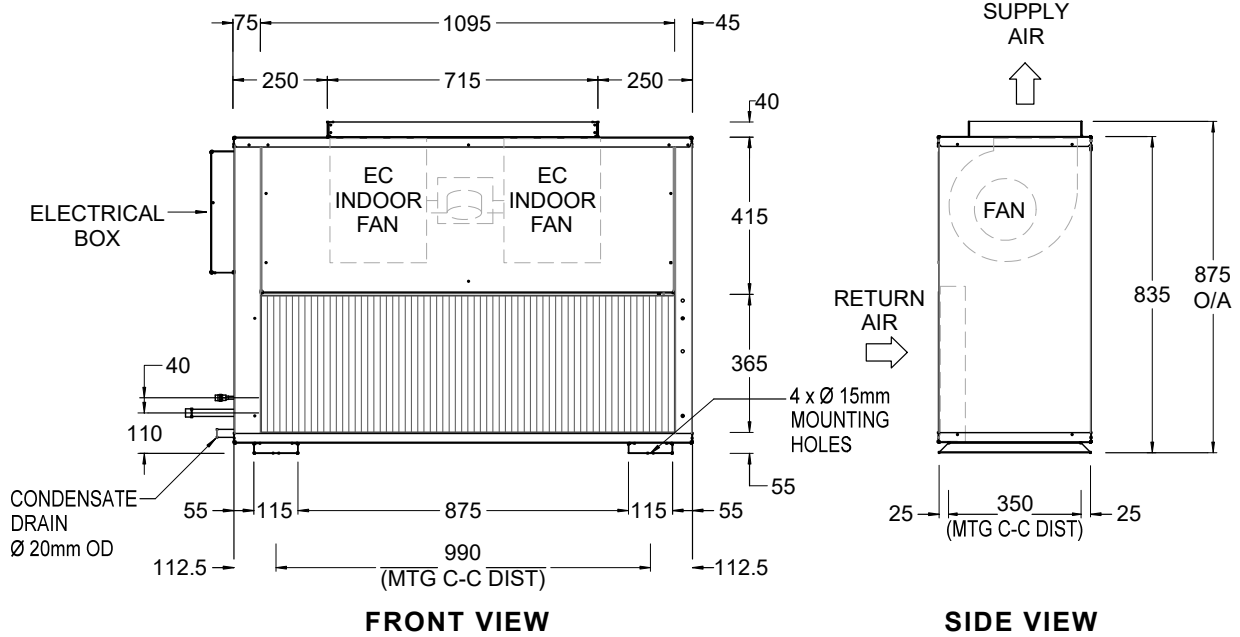
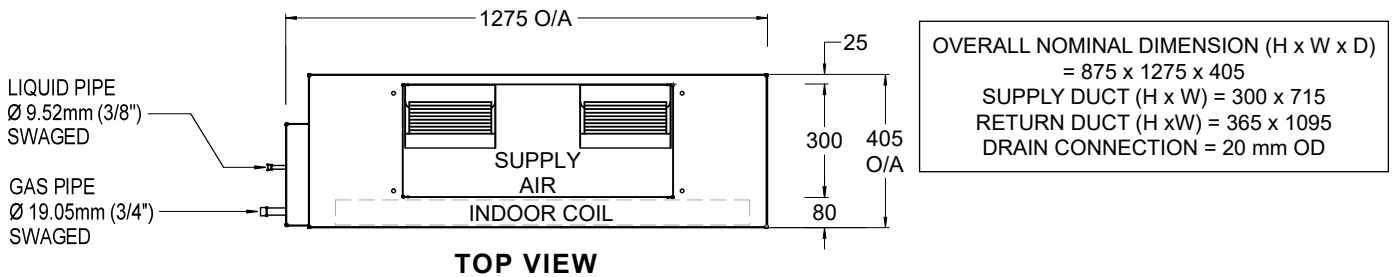

1 Phase
1 Stage
14.25 kW

MINIMUM SERVICE ACCESS CLEARANCES & AIRFLOW SPACE ALLOWANCES

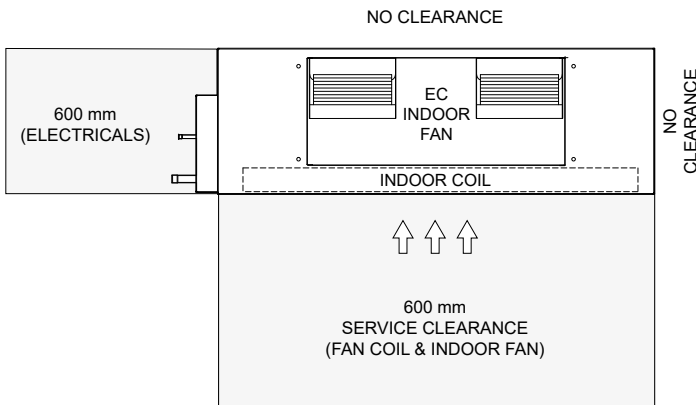

HEIGHT CLEARANCE = DUCT WORK

TOP VIEW

NOTES:

1. Do not scale drawing. All dimensions are in mm unless specified. Refer to corresponding unit dimensional drawing for mounting hole details.
2. Service Access Areas and Spaces for Airflow Clearances given are suggested minimum based on the condition that the spaces around the units are free from any obstructions and a walkway passage of 1000 mm between the units or between the unit and the outside perimeter is available.
3. Minimum Service Access Areas and Spaces for Airflow Clearances are responsibilities of the installer, ActronAir will not be held liable for any extra charges incurred due to lack of access and space for airflow.
4. Refer to the Fan Curve of the standard EVV model.

