

# ADVANCE SPLIT DUCTED UNIT

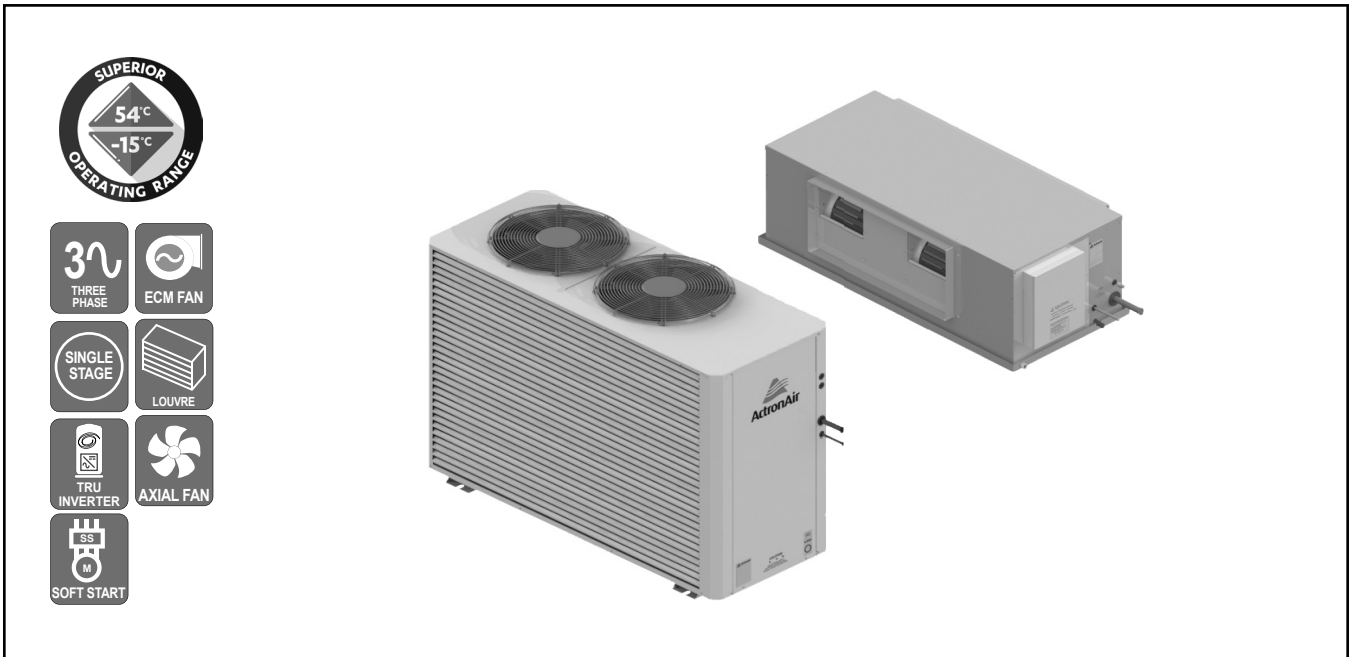

3 Phase  
1 Stage  
19.40 kW

## UNIT FEATURES

- Tru-Inverter™ Variable Speed Compressor and Drive Technology
- 20-100% Superior Refrigeration Operating Capacity Range
- ECM High Efficiency Indoor Fan Motor
- Three Speed Outdoor Fans
- Adaptive Demand Defrost
- Active Power Factor Correction
- 20m Cat5e wall controller cable included
- Low ambient cooling operation to +5 degree
- Fault and Run Indication - Relay Output
- Up to 3 Wall Controllers and 3 Remote Temperature Sensors
- Ready for up to 8 zones
- Compressor Soft Start via Variable Speed Drive Control
- Hydrophilic Blue Fin Coil Coat Protection - Indoor and Outdoor Coils
- Integrated Fan Coil Safety Tray with Drain Kit
- Pre-charged with R-410A Refrigerant
- Bi-Flow Electronic Expansion Valve
- Powder Coated Outdoor Unit with Louvred Coil Guard
- Variable Fan Technology
- Turbo Mode

## CONTROL OPTIONS AND FEATURES

### ActronAir LR7-1/LC7-2

- Available in White or Grey
- 7-day Programmable Controller with 2 Events per Day
- 24-hour ON/OFF Timer
- Temperature Setback
- After Hours Time (LC7-2 Only)
- Auto, Heat, Cool, Turbo, Fan Modes and Night Mode Functions
- Fixed, Auto and Continuous Indoor Fan Operation
- Optional 2nd and 3rd Controllers with Mimic Logic
- On-board Temperature Sensor

### ActronAir NEO

- 7" Colour Touch Screen Master Controller
- In-built Wi-Fi and Blue-Tooth
- Neo Connect App
- On-Board Temperature, Humidity and Proximity Sensor
- Optional wireless Zone Controller with on-board sensor
- Optional wireless Zone Sensor
- Available in White or Black

### ActronAir Group Control

### ActronAir BMS ICUNO-MOD (Modbus 485)

## THIRD PARTY CONTROL OPTIONS

- Manual and Analogue Inputs

## PLENUMS (Optional)

- Supply Air Plenums are available in 2 or 3 way Configuration (See Accessories Sec. for details of spigots availability)
- Return Air Plenums are available with 2 x 350 mm or 2 x 400 mm Spigots

## SPECIFICATION SUMMARY

OUTDOOR UNIT MODEL	CRV210T		
INDOOR UNIT MODEL	EVV210S		
		(1) TOTAL	(2) NETT
(3) COOLING CAPACITY (kW)	MINIMUM	5.30	5.20
	RATED	19.40	19.00
	TRUMAX (9)	21.55	21.00
(4) HEATING CAPACITY (kW)	MINIMUM	4.50	4.60
	RATED	19.60	20.00
	TRUMAX (9)	22.45	23.00
(3) SENSIBLE CAPACITY (kW)	RATED	15.98	15.58
(5) COOLING INPUT POWER (kW)	RATED	5.70	
(5) HEATING INPUT POWER (kW)	RATED	5.50	
EER	RATED	3.66	3.33
COP	RATED	3.84	3.64
(6) INDOOR AIRFLOW (l/s) - MIN. / NOMINAL / MAX.	350 / 1020 / 1230		
OUTDOOR SOUND PRESS. LEVEL @ 3M dB(A) - LOW / HIGH	41.9 / 60.0		
OUTDOOR SOUND POWER LEVEL dB(A) - LOW / HIGH	61.3 / 79.6		
POWER SUPPLY - OUTDOOR	400V/3Ph+N/50Hz		
POWER SUPPLY - INDOOR	230V/1Ph+N/50Hz		
(2) RATED LOAD AMPS -- OUTDOOR / INDOOR / TOTAL	7.8 / 3.6 / 11.4		
(7) FULL LOAD AMPS -- OUTDOOR / INDOOR / TOTAL	16.4 / 5.5 / 21.9		
(8) CIRCUIT BREAKER AND CABLE AMPS	25		
APPROXIMATE STARTING AMPS	< 45		
POWER FACTOR	0.96		
WEIGHT (kg) -- INDOOR / OUTDOOR	75 / 200		

(1) Based on unit rating excluding indoor fan kW.

(2) Measured and tested in accordance with AS/NZS 3823.1.2.

(3) At 27°C DB / 19°C WB entering air temperatures and 35°C ambient.

(4) At 20°C DB entering air temperature and 7°C DB / 6°C WB ambient.

(5) Total input power excludes indoor fan kW.

Nett input power includes indoor fan kW.

(6) Max. - Min. airflow application range.

(7) Full Load Amps are based on compressor and fan motors' maximum expected current.

(8) See Specifications sheet for cable size and circuit breaker size details.

(9) TRUMAX - Maximum Capacity.

Note: Use nett input power to estimate running cost.

## UNIT OPTIONS

- Additional Full Coil Coat Protection
- Split Fan Coil Unit
- Vertical Fan Coil Unit
- Horizontal Discharge Condenser
- Outdoor Drain Tray





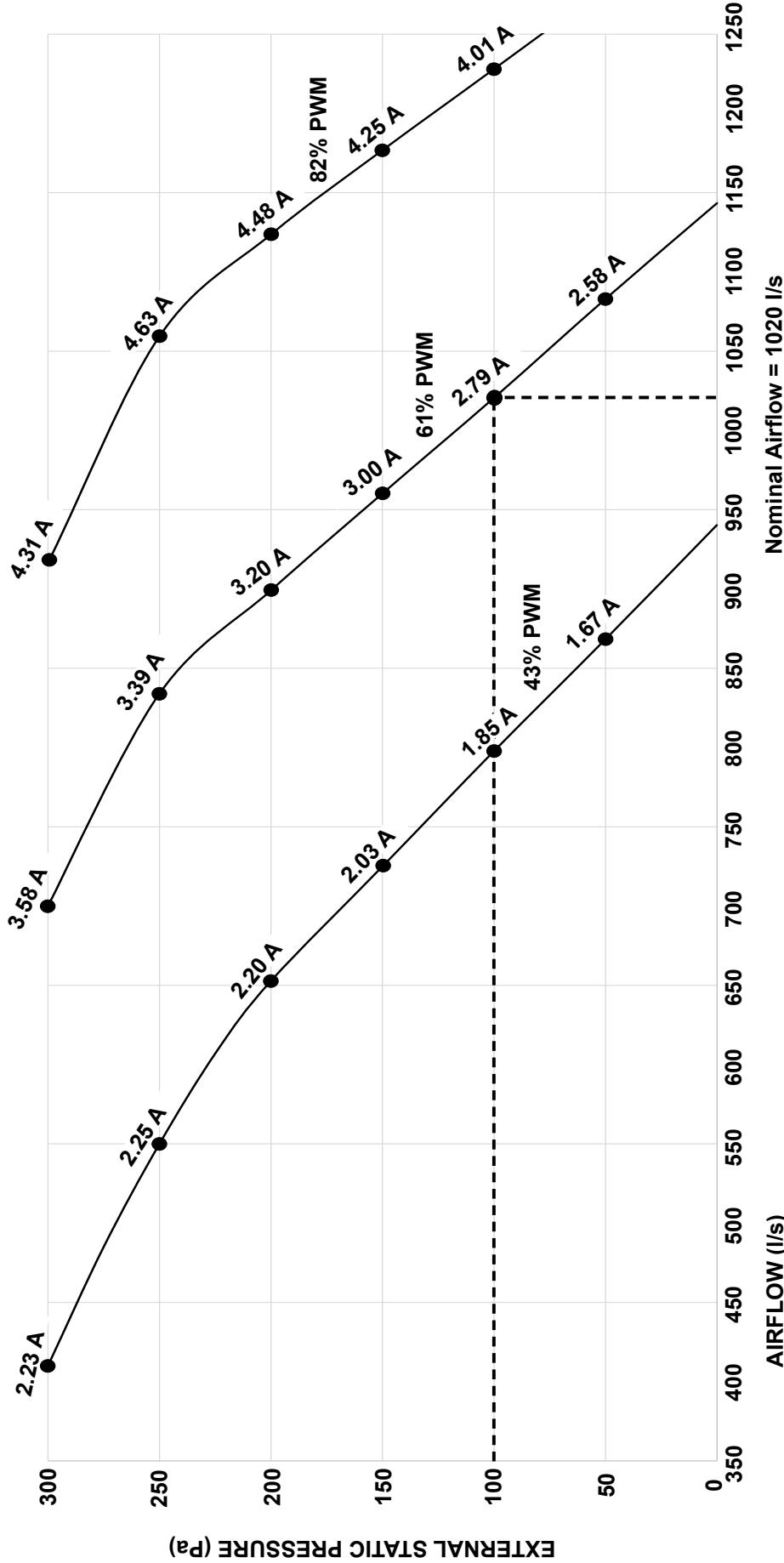

Nominal Airflow = 1020 l/s

Hi-Mid-Low Speed Airflow Range

Variable Fan Technology Airflow Range

3 Phase  
1 Stage  
19.40 kW



19.40 kW  
3 Phase 1 Stage

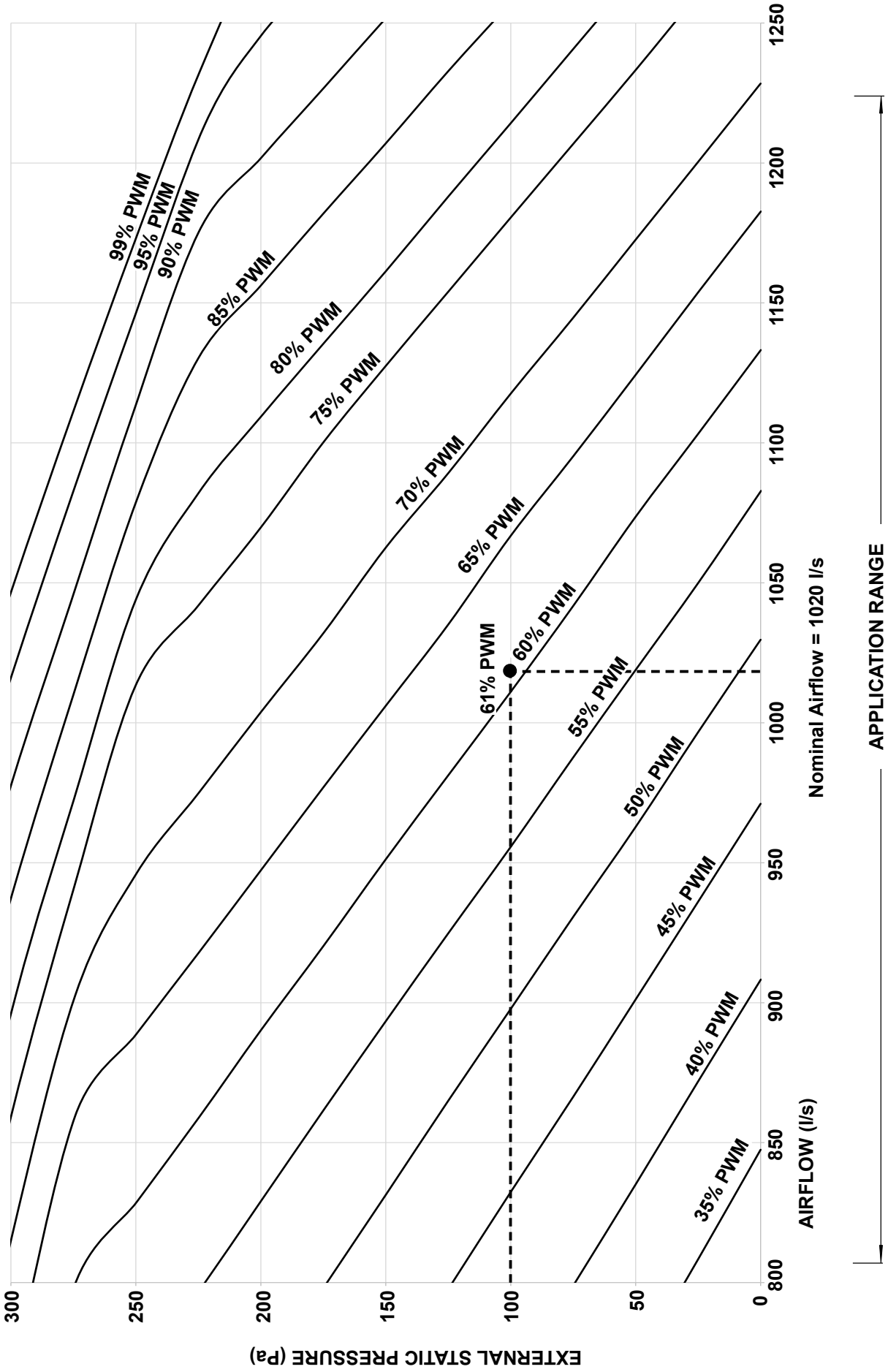

# OUTDOOR UNIT DIMENSIONS

# CRV210T

## C OUTDOOR UNIT - STANDARD MODEL

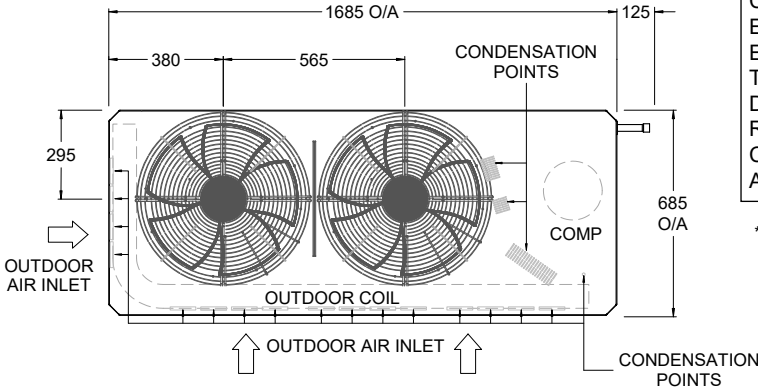

**TOP VIEW**

CONDENSATION POINTS ARE DESIGNED TO ENSURE ALL CONDENSATION IS REMOVED EFFICIENTLY TO AVOID WATER POOLING WITHIN THE CONDENSER. IF A SINGLE CONDENSATION DRAIN POINT IS REQUIRED, ACTRONAIR RECOMMENDS THE INSTALLATION OF A CONDENSER TRAY. THESE ARE AVAILABLE AS AN ADDITIONAL ACCESSORY.

\*\* DRAWING IS SUBJECT TO CHANGE WITHOUT NOTICE\*\*

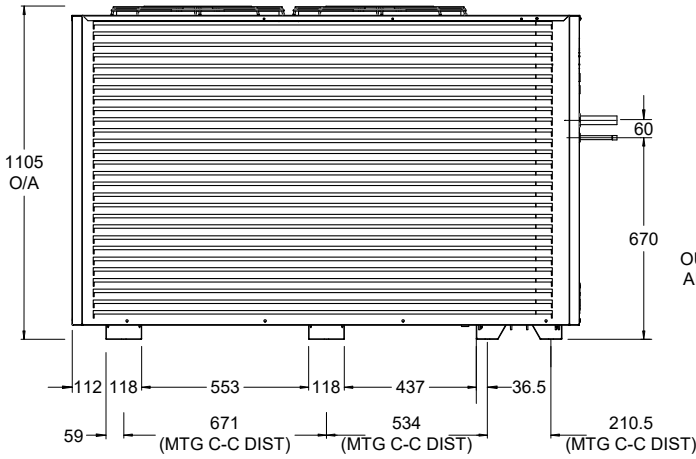

**SIDE VIEW**

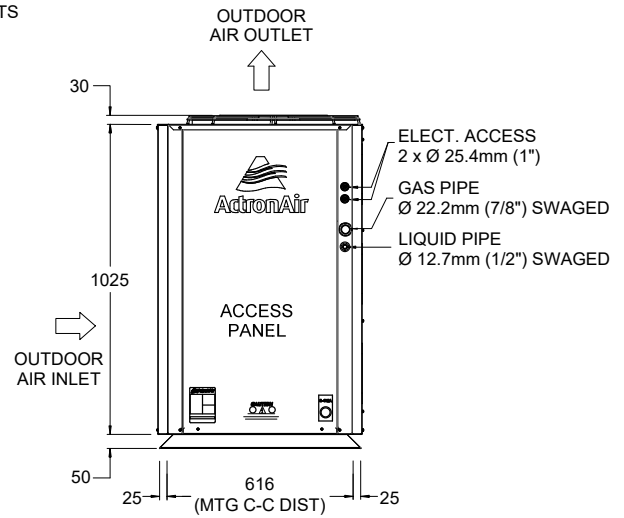

**FRONT VIEW**

UNIT MODEL NUMBER	UNIT WEIGHT (kg)	CORNER WEIGHTS (kg)			
		A	B	C	D
CRV210T	200	27	53	48	72

### MINIMUM SERVICE ACCESS AREAS AND AIRFLOW CLEARANCES

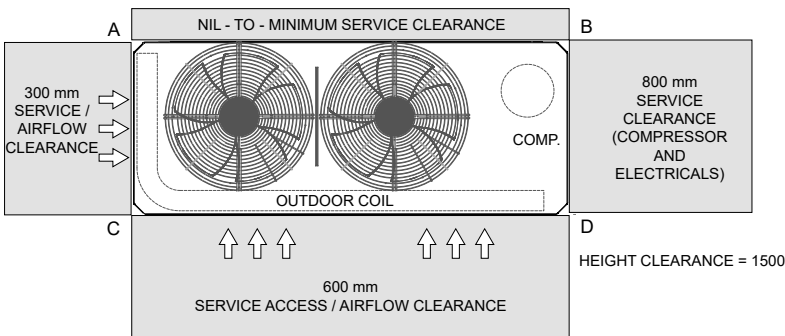

**NOTES:**

- Do not scale drawing. All dimensions are in mm unless specified. Refer to corresponding unit dimensional drawing for mounting hole details.
- Service Access Areas and Spaces for Airflow Clearances given are suggested minimum based on the condition that the spaces around the units are free from any obstructions and a walkway passage of 1000 mm between the units or between the unit and the outside perimeter is available.
- Minimum service access areas and spaces for airflow clearances are responsibilities of the installer, ActronAir will not be held liable for any extra charges incurred due to lack of access and space for airflow.
- Under all circumstances, condenser air must not recirculate back onto condenser coil. Keep all clearance free of any obstructions.
- Maximum External Static of Outdoor Fans is 5 Pa.
- STACKING OF UNITS: Ensure that minimum airflow and clearances are met.
- Refer to pipe Connection Details on Specifications Sheet.
- MTG C-C DIST = Mounting Centre to Centre Distance.
- Use M12 bolt for feet mounting.

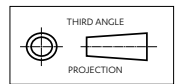

3 Phase  
1 Stage  
19.40 KW



## E INDOOR UNIT - STANDARD MODEL

19.40 kW  
3 Phase 1 Stage

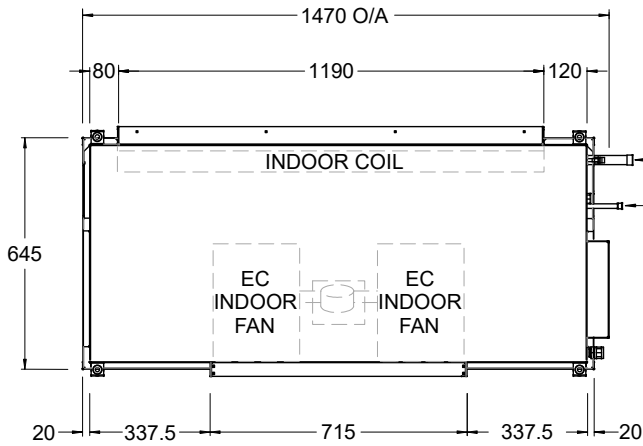

**TOP VIEW**

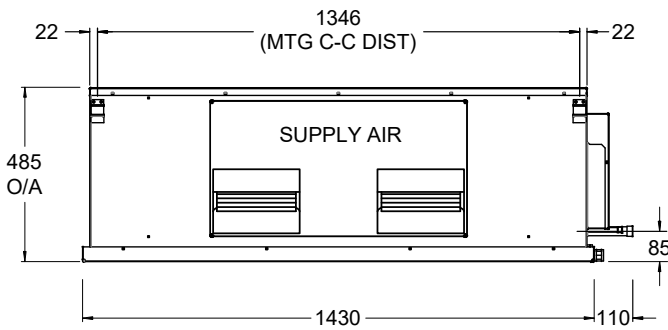

**FRONT VIEW**

GAS PIPES  
Ø 25.4 mm (1")  
SWAGED

LIQUID PIPES  
Ø 12.7 mm (1/2")  
SWAGED

OVERALL NOMINAL DIMENSION (H x W x D)  
= 485 x 1470 x 695  
SUPPLY DUCT (H x W) = 380 x 715  
RETURN DUCT = 410 x 1190

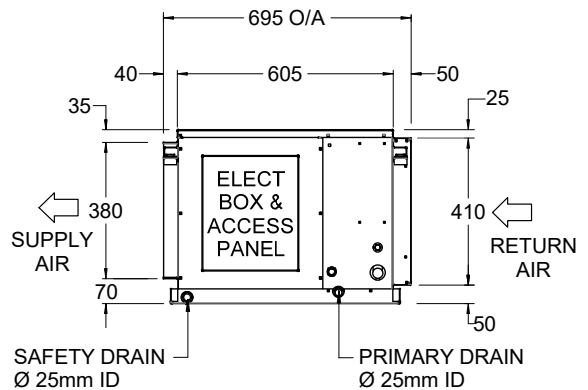

**SIDE VIEW**

UNIT MODEL NUMBER	UNIT WEIGHT
EVV210S	75

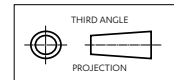

**NOTES:**

1. Do not scale drawing. All dimensions are in mm unless specified. Refer to corresponding unit dimensional drawing for mounting hole details.
2. Service Access Areas and Spaces for Airflow Clearances given are suggested minimum based on the condition that the spaces around the units are free from any obstructions and a walkway passage of 1000 mm between the units or between the unit and the outside perimeter is available.
3. Minimum Service Access Areas and Spaces for Airflow Clearances are responsibilities of the installer, ActronAir will not be held liable for any extra charges incurred due to lack of access and space for airflow.

### MINIMUM SERVICE ACCESS AREAS AND AIRFLOW CLEARANCES

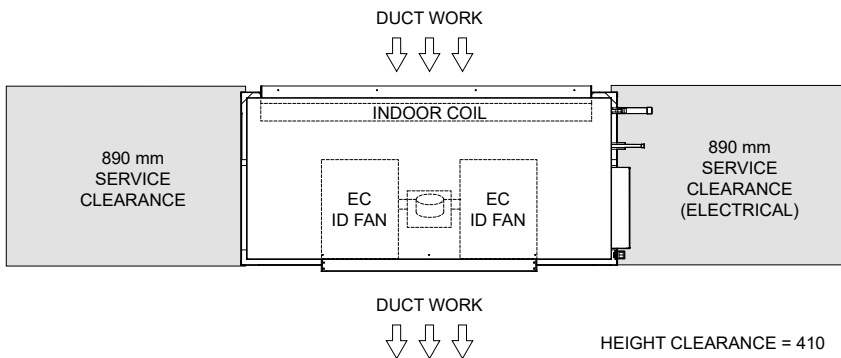

**Outdoor Radiated**

**Sound Power Level (SWL)**

Fan Speed	Sound Power Level dB(A)	Octave Band Centre Frequency (Hz), dB						
		125	250	500	1k	2k	4k	8k
Low	61.3	61.3	58.8	59.3	55.6	53.5	49.3	40.4
Medium	65.7	76.2	65.5	63.8	57.8	53.8	48.6	42.4
High	79.6	81.0	80.2	77.3	74.7	70.2	63.9	54.8

**Indoor Outlet**

**Sound Power Level (SWL)**

Airflow Setting	Airflow l/s	Sound Power Level dB(A)	Octave Band Centre Frequency (Hz), dB						
			125	250	500	1k	2k	4k	8k
Nominal	1020	72.1	72.8	72.0	67.9	70.3	66.3	64.3	61.3

3 Phase  
1 Stage  
19.40 kW

**OUTDOOR RADIATED**

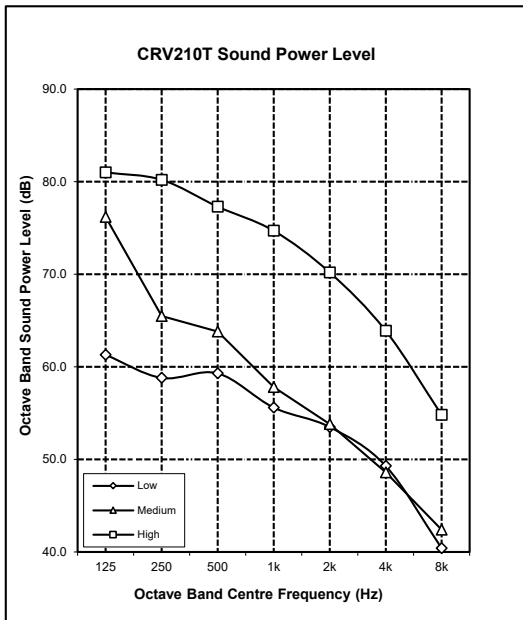

**INDOOR OUTLET**

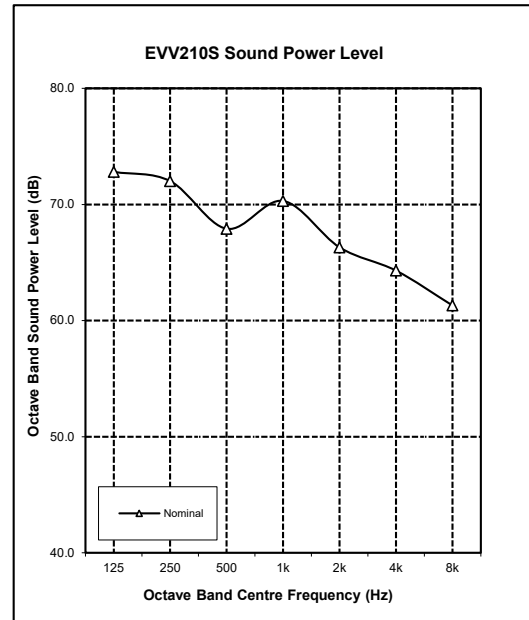

**NOTES:**

Radiated sound power levels are based on ISO 3743-1.

# SPECIFICATIONS

# CRV210T / EVV210S

19.40 kW  
3 Phase 1 Stage

CONSTRUCTION	
CABINET (Indoor Unit)	0.5 - 0.9 mm Galvanised Steel
CABINET (Outdoor Unit)	0.9 - 1.2 mm Galv. Steel
SURFACE FINISH (Outdoor Unit)	65 µ Baked Polyester Powder Coat

INSULATION	
TYPE - (Indoor Unit)	Foil Faced Polyethylene Expanded Polystyrene

SOUND LEVEL * dB(A)	
SOUND PRESS. - Low / High	41.9 / 60.0
SOUND POWER LEVEL - Low / High	61.3 / 79.6
* Sound data are based on outdoor fan's manufacturer sound level data.	

ELECTRICAL	
OUTDOOR UNIT	
Power Supply - 50 Hz	400 Volts x 3 Phase + N
Voltage Range (min - max)	380 V - 440 V
Full Load Amps*	16.4
Rated Load Amps**	7.8
Approximate Starting Amps	< 45.0
IP Rating	IP44
INDOOR UNIT	
Power Supply - 50 Hz	230 Volts x 1 Phase + N
Voltage Range (min - max)	216 V - 253 V
Full Load Amps*	5.5
IP Rating	IP20

OUTDOOR & INDOOR UNIT (TOTAL)	
Full Load Amps* - Phase 1	21.9
Full Load Amps* - Phase 2 & 3	14.2 & 14.2
Rated Load Amps**	11.4
IMPORTANT - The local electricity authority may require limits on starting current and voltage drop, please check prior to purchase.	
* Full Load Amps are based on Compressor and Fan Motor's maximum expected current.	
** Rated Load Amps are measured and tested in accordance with AS/NZS3823.1.2.	

CABLE SIZE & CIRCUIT BREAKER SIZE	
Suggested minimum cable size should be used as a guide only, refer to AS/NZS 3000 "Australian/New Zealand Wiring Rules" for more details.	
Cable Size (main line)	4.0 mm <sup>2</sup> (SUGGESTED MINIMUM)
Cable Size (indoor to outdoor wire)	1.5 mm <sup>2</sup> (SUGGESTED MINIMUM)
Circuit Breaker Size	25.0 Amps
Data Cable Field Wiring (Outdoor-to-Indoor)	2 Core 7 / 0.30 (0.5mm <sup>2</sup> ) Twisted Shielded Data Cable

OUTDOOR COIL	
TUBE TYPE	Copper - Rifle Bore
FIN TYPE	Aluminium - Wave
FACE AREA (m sq)	1.51
FIN SPACING (per m)	472
COIL COATING	Hydrophilic Blue Fin Coil Coat Protection

OUTDOOR FAN	
NUMBER OF FANS x TYPE	2 x Axial
NUMBER OF BLADES PER FAN	5
DIAMETER (mm)	500
OUTPUT kW (each)	0.27
MOTOR TYPE / DRIVE TYPE	6 Pole External Rotor / Direct
FAN SPEED CONTROL	3 Speed via Capacitor
The standard type outdoor fans fitted to this unit will only accept 5 Pa of external static resistance.	

INDOOR COIL	
TUBE TYPE	Copper - Rifle Bore
FIN TYPE	Aluminium - Louvre
FACE AREA (m sq)	0.41
FIN SPACING (per m)	472
COIL COATING	Hydrophilic Blue Fin Coil Coat Protection

INDOOR FAN	
NUMBER OF FANS x TYPE	2 wheels x Centrifugal EC Fan
DIAMETER (mm) x WIDTH (mm)	240 x 180
INPUT kW (each)	0.40
MOTOR TYPE / DRIVE TYPE	Variable Speed EC Motor / Direct
FAN SPEED CONTROL	Electronic Control

COMPRESSOR	
NUMBER PER UNIT x TYPE	1 x Variable Speed Scroll (Hermetic)
FULL LOAD AMPS	14.2
STARTING METHOD	Soft Start via Variable Speed Drive

REFRIGERATION SYSTEM	
REFRIGERANT TYPE	R-410A
EXPANSION CONTROL	Direct Expansion Orifice / EEV
FACTORY CHARGE (grams)	7400
PRE-CHARGE LENGTH (metres)	15
ADDITIONAL REF. CHARGE (gm/m)	50      100

FILTER DRIER	
CONNECTION SIZE & TYPE	9.52 mm (3/8") ODF Soldered Bi-Flow
FACTORY SUPPLIED / FITTED	No

INTERCONNECTING PIPE RUN	
MAX PIPE LENGTH (metres)	0-20      20-60
MAX. VERTICAL LENGTH (metres)	20 (Included in Max. Pipe Length)
FIELD PIPE SIZES	
Liquid Pipe	9.52 mm (3/8")      12.7 mm (1/2")
Gas Pipe	22.2 mm (7/8")      25.4 mm (1")

PIPE CONNECTIONS		
Indoor	Liquid Pipe	12.7 mm (1/2") Swaged to fit 12.7 mm (1/2") field pipe or Cut to fit 9.52 mm (3/8") field pipe
	Gas Pipe	25.4 mm (1") Swaged to fit 25.4 mm (1") field pipe or Cut to fit 22.2 mm (7/8") field pipe
Outdoor	Liquid Pipe	12.7 mm (1/2") Swaged to fit 12.7 mm (1/2") field pipe or Cut to fit 9.52 mm (3/8") field pipe
	Gas Pipe	22.2 mm (7/8") Swaged to fit 22.2 mm (7/8") field pipe or Cut to fit 25.4 mm (1") field pipe
CONNECTION TYPE		Solder
Insulate both gas and liquid pipes separately.		

PROTECTION DEVICES	
HIGH PRESSURE CUTOUT SWITCH	Nonadjustable (Automatic Reset)
LOW PRESSURE CUTOUT SWITCH	Nonadjustable (Automatic Reset)
COMPRESSOR MOTOR TEMP.	Internal Thermal Cut-Out
INDOOR FAN OVERLOAD	Internal Thermal Cut-Out
OUTDOOR FAN OVERLOAD	Internal Thermal Cut-Out
SUMP HEATER WATTS*	37W during compressor off cycle
*Crankcase Heater is to be disconnected for pipe lengths 8 m or less.	

ELECTRONIC CONTROLS	
DEFROST METHOD	Reverse Cycle
DEFROST TYPE	Adaptive Demand Defrost
CONTROL CIRCUIT BREAKER	16.0 Amps
MASTER/SECONDARY CONTROLLER CABLE SPECS.	Cat5e with RJ45 Connectors and cable boots.

OPERATING RANGE			
It is essential that the unit is correctly sized for the application and operates within its recommended range of operating conditions as shown below.			
MODE	RANGE	INDOOR AIR INTAKE TEMPERATURE	OUTDOOR AIR INTAKE TEMPERATURE
Cooling	Max.	30°C DB / 22°C WB	54°C DB
	Min.	20°C DB / 16°C WB	5°C DB
Heating	Max.	24°C DB	19.5°C DB / 18°C WB
	Min.	16°C DB	-15°C DB

AIR FILTERS	
All return air including fresh air must have adequate filters supplied and fitted by the installing contractor. Filters must be located in accessible location between the return air grille and the unit. ActronAir does not supply or make any provisions for return air filter.	

- UNIT COMPLIANCE**
- AS/NZS 3823.2 (MEPS)
  - AS/NZS 4755.3.1 (DRM 1, 2 and 3)
  - AS/NZS CISPR 14.1 (EMC)
  - AS/NZS 60335.1 (ELECTRICAL APPLIANCE SAFETY)
  - AS/NZS 60335.2.40 (ELECTRICAL APPLIANCE SAFETY - AIR CONDITIONERS)







CRV210T-0200

19.40 kW  
3 Phase  
1 Stage

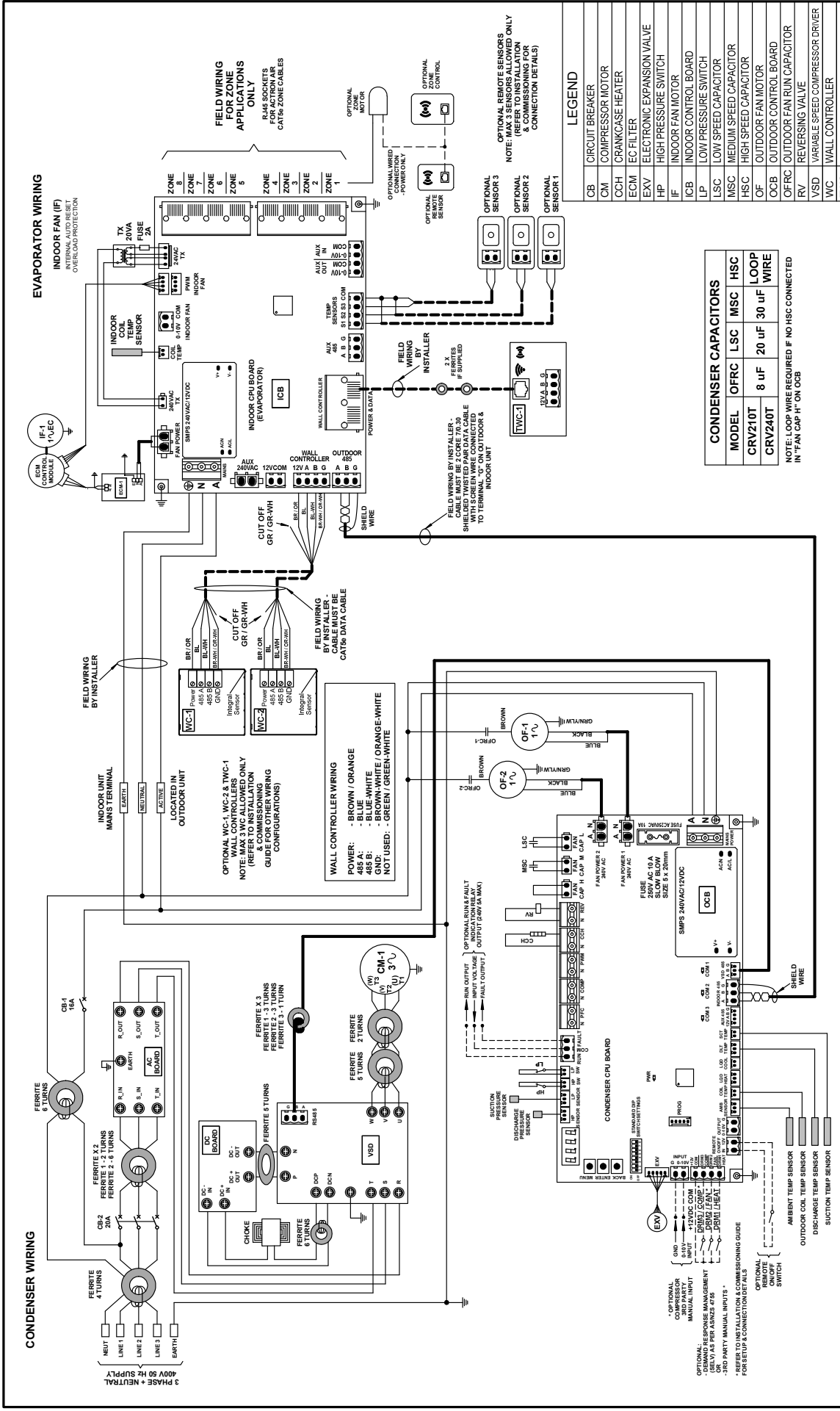

**ActronAir**

This drawing remains the intellectual property of Actron Engineering Pty Ltd. Reproduction, modification and/or distribution are prohibited without written consent.

Base Model No:	CRV210/240T	Variation Code:	STANDARD
Description:	UNO SERIES CONTROL SYSTEM WIRING DIAGRAM WITH INZONE SERIES INDOOR BOARD & WALL CONTROL	Revision:	A
Drawn:	RL	Date:	08-12-2022
Approved:	JL	Date:	08-12-2022
Drawing No:	WD2060	Size:	A4

Rev.	Description	By	Date
A	ORIGINAL	PCR	

## H OUTDOOR UNIT - HORIZONTAL DISCHARGE FANS

OVERALL NOMINAL DIMENSION (H x W x D)  
= 1075 x 1685 x 715

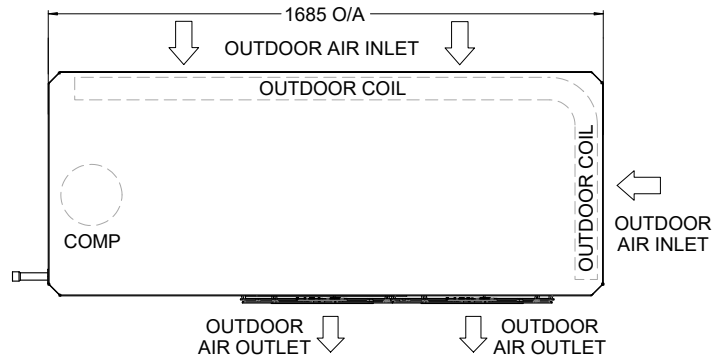

TOP VIEW

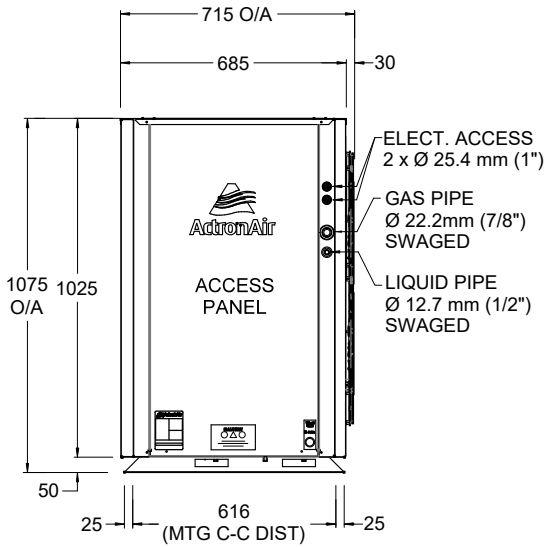

SIDE VIEW

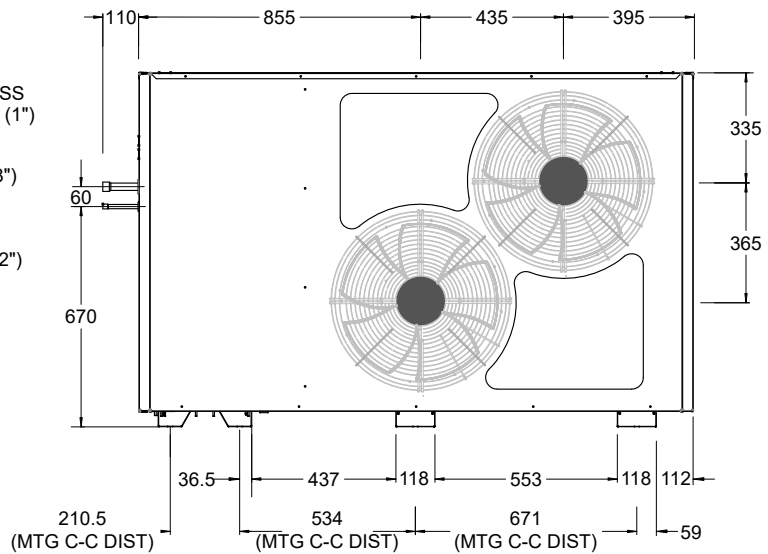

FRONT VIEW

3 Phase  
1 Stage  
19.40 kW

### MINIMUM SERVICE ACCESS CLEARANCES & AIRFLOW SPACE ALLOWANCES

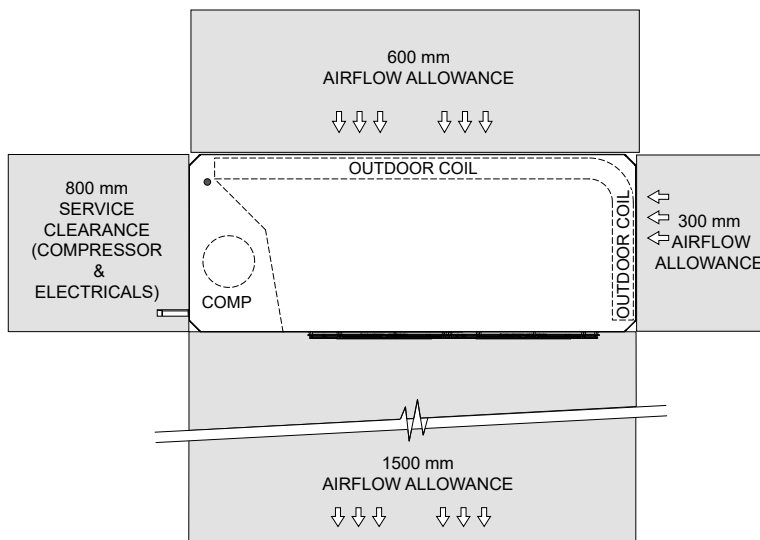

TOP VIEW

HEIGHT CLEARANCE = 450

#### NOTES:

1. Do not scale drawing. All dimensions are in mm unless specified. Refer to corresponding unit dimensional drawing for mounting hole details.
2. Service Access Areas and Spaces for Airflow Clearances given are suggested minimum based on the condition that the spaces around the units are free from any obstructions and a walkway passage of 1000 mm between the units or between the unit and the outside perimeter is available.
3. Minimum service access areas and spaces for airflow clearances are responsibilities of the installer, ActronAir will not be held liable for any extra charges incurred due to lack of access and space for airflow.
4. Under all circumstances, condenser air must not recirculate back onto condenser coil. Keep all clearance free of any obstructions.
5. Maximum External Static of Outdoor Fans is 5 Pa.
6. STACKING OF UNITS: Ensure that minimum airflow and clearances are met.
7. Refer to pipe Connection Details on Specifications Sheet.
8. MTG C-C DIST = Mounting Centre to Centre Distance.
9. Use M12 bolt for feet mounting.

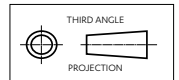

## V INDOOR UNIT - UPRIGHT FAN COIL WITH VERTICAL DISCHARGE

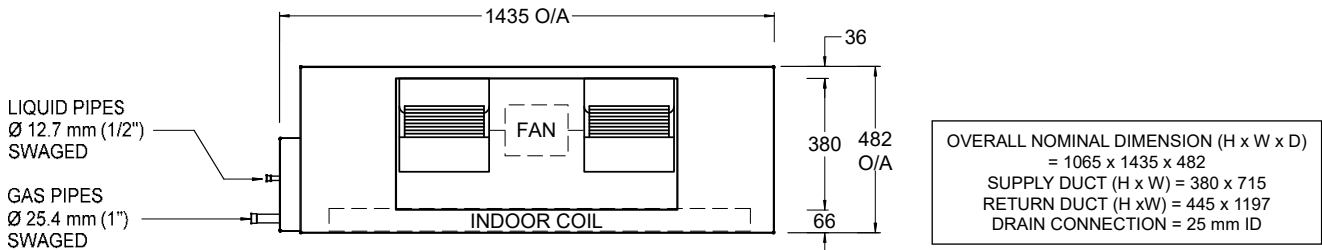

TOP VIEW

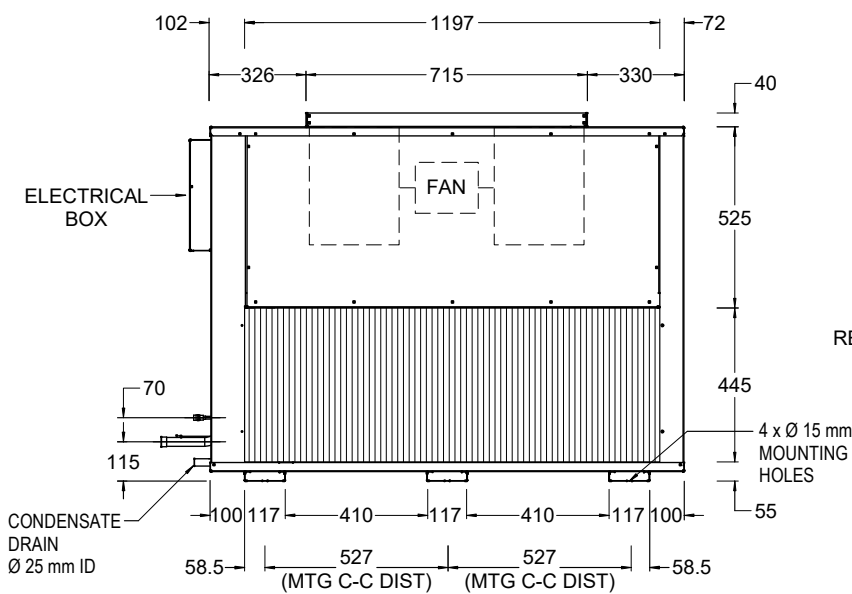

FRONT VIEW

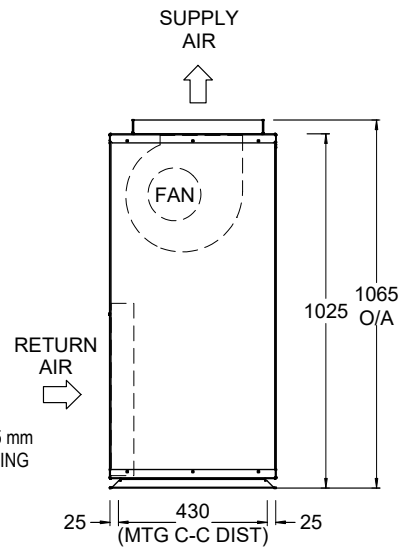

SIDE VIEW

### MINIMUM SERVICE ACCESS CLEARANCES & AIRFLOW SPACE ALLOWANCES

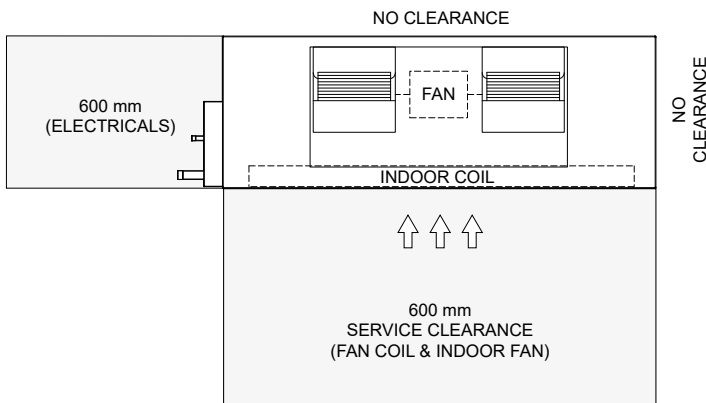

HEIGHT CLEARANCE = DUCT WORK

TOP VIEW

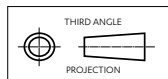

THIRD ANGLE  
PROJECTION

**NOTES:**

- Do not scale drawing. All dimensions are in mm unless specified. Refer to corresponding unit dimensional drawing for mounting hole details.
- Service Access Areas and Spaces for Airflow Clearances given are suggested minimum based on the condition that the spaces around the units are free from any obstructions and a walkway passage of 1000 mm between the units or between the unit and the outside perimeter is available.
- Minimum Service Access Areas and Spaces for Airflow Clearances are responsibilities of the installer, ActronAir will not be held liable for any extra charges incurred due to lack of access and space for airflow.
- Refer to the Fan Curve of the standard EVV model.