

# Serene 2 Wall Hung Split System

Installation and Commissioning Guide



## Model Numbers

WRC-026CS / WRE-026CS

WRC-035CS / WRE-035CS

WRC-050CS / WRE-050CS

WRC-072CS / WRE-072CS

WRC-085CS / WRE-085CS



### **IMPORTANT NOTE:**

Please read this manual carefully before installing or operating your air conditioning unit. Make sure to save this manual for future reference.



### **CAUTION:**

The system is charged with flammable refrigerant, safety checks are necessary to ensure that the risk of ignition is minimised.

**ActronAir**

## Table of Contents

<b>01. Symbols</b> .....	<b>3</b>
<b>02. Inspection</b> .....	<b>3</b>
02.01. Product Inspections	3
02.02. Codes, Regulations and Standards	3
<b>03. General Information</b> .....	<b>3</b>
<b>04. Safety Instructions</b> .....	<b>4</b>
<b>05. Installation Information</b> .....	<b>5</b>
<b>06. Components</b> .....	<b>7</b>
<b>07. Installation Summary</b> .....	<b>8</b>
<b>08. Parts Overview</b> .....	<b>11</b>
<b>09. Indoor Unit Installation</b> .....	<b>12</b>
<b>10. Outdoor Unit Installation</b> .....	<b>22</b>
<b>11. Refrigeration Piping Connection</b> .....	<b>27</b>
<b>12. Wiring</b> .....	<b>30</b>
12.01. Outdoor Unit Wiring	32
12.02. Indoor Unit Wiring	33
12.03. Indoor Unit Wiring Diagram	35
12.04. Outdoor Unit Wiring Diagram (WRC-026CS/WRC-035CS)	36
12.05. Outdoor Unit Wiring Diagram (WRC-050CS/WRC-072CS/WRC-085CS)	37
12.06. Electrical Connection	38
<b>13. Leak Test and Air Evacuation</b> .....	<b>39</b>
13.01. Leak Test	39
13.02. Evacuation Instructions	40
13.03. Refrigerant Charge Details	41
<b>14. Electrical and Gas Leak Checks</b> .....	<b>42</b>
14.01. Electrical Safety Checks	42
14.02. Gas Leak Checks	42
<b>15. Test Run</b> .....	<b>43</b>
<b>16. Maintenance</b> .....	<b>45</b>
<b>17. Maintenance Frequency Checklist</b> .....	<b>46</b>
<b>18. Start up and Commissioning Report</b> .....	<b>49</b>

Product design and specifications are subject to change without prior notice for product improvement.

### READ SAFETY PRECAUTIONS BEFORE INSTALLATION

Incorrect installation due to ignoring instructions can cause serious damage or injury. The seriousness of potential damage or injuries is classified as either a **WARNING** or **CAUTION**.



**CAUTION**

Failure to observe a caution may result in injury or equipment damage.



**WARNING**

Failure to observe a warning may result death or serious injury.





FOR COMPLIANCE WITH QUEENSLAND  
ELECTRICAL SAFETY REGULATIONS 2013  
This refers to electrical works only



**MUST BE INSTALLED BY A LICENSED  
ELECTRICIAN**

## 01. Symbols

Explanation of symbols displayed on the air conditioner. Information About This Guide

	This symbol shows that this appliance uses a flammable refrigerant. If the refrigerant leaks and exposed to an external ignition source, there is a risk of fire.
	This symbol shows that the Operation Manual should be read carefully.
	This symbol shows that a service person should be handling this equipment with reference to the Installation Manual.
	This symbol shows that there is information included in the Operation Manual and Installation Manual.

## 02. Inspection

### 02.01. Product Inspections

Check your air conditioning unit and all items against the invoice upon receiving your shipment. Inspect the unit, components and accessories for any sign of damage. If there is any damage to the unit, contact ActronAir Customer Care Department immediately on: **1300 522 722** to obtain a Goods Return Number.

Check the unit nameplate to verify the model, serial number, electrical rated specifications are correct.

### 02.02. Codes, Regulations and Standards

The installer and/or contractor assumes responsibility to ensure that unit installation complies with the relevant council, state / federal codes, regulations and building code standards. All electrical wiring must be in accordance with current electrical authority regulations and all wiring connections to be as per electrical diagram provided with the unit.

## 03. General Information

The ActronAir air conditioning units are designed for applications where superior performance, high efficiency, reliability, supply air quality and quiet operation are the prime priorities.

For optimum efficiency, your air conditioning unit will deliver just the right amount of cooling or heating capacity you demand. Even in extreme conditions, the unit will still supply the required demand at peak performance.

### Energy Efficient Refrigeration Circuits

The ActronAir system is designed with a split ducted refrigeration circuit that delivers only the amount of cooling or heating actually required to maintain your desired comfort at the most optimum efficiency.

Each refrigeration circuit consists of:

- High efficiency inverter scroll compressor.
- Gold epoxy coat coil protected condenser designed for optimum performance and efficiency with corrugated fins and riffled tubing.
- Gold epoxy coat coil protected evaporator coil designed for optimum performance and efficiency with lanced fins and riffled tubing.

### Evaporator Section

The evaporator section has DC fans which deliver just the right amount of airflow, depending on requirements. The fans provide superior performance for your comfort at optimum efficiency:

- Highly efficient variable speed DC motor that uses less energy.
- Easy variable indoor fan commissioning via intelligent controllers.
- Low noise operation.

**Condenser Section**

Single DC inverter fan motor, with the following features:

- Low noise operation.
- Inverter rotary compressor.

**Electrical Section**

The electrical section is composed of a separate panel for controls, protecting the components from the elements.

**Durable Design and Construction**

ActronAir is an Australian manufacturer with proven high quality air conditioning products. Known for their durability and reliable performance, these products are designed and built to withstand the extreme weather conditions.

The galvanized steel cabinet, with powder coated epoxy enamel finish, resists the toughest conditions.

Gold Epoxy Coat Coil Protection heat exchangers ensures an enhanced heat transfer with increased performance efficiency.

**System Flexibility**

The ActronAir air conditioning units are the first choice for residential, office, schools and other air conditioning facilities applications, both for new construction or retrofitting projects.

**Refrigerant Handling and Accountability**

ActronAir strongly urges that all service technicians make every effort to eliminate the emission of refrigerants to the atmosphere. Everyone must act in a responsible manner to conserve refrigerants.

**Sustainability and Environmentally Friendly**

The air conditioning system is supplied with zero ozone depleting low GWP R-32 refrigerant, which has no phase out or replacement concern.

With cooling and heating performance capacity that are among the best in the market, the ActronAir air conditioning units provide the solution for the reduction of energy consumption, CO<sub>2</sub> emission, high fuel dependency and high network grid demand.

## **04. Safety Instructions**

- Only licensed HVAC technicians\* should install and service this air conditioning equipment. Improper service or alteration by an unqualified technician could result in significant and major damage to the product or property which may render your warranty null and void. Such unqualified service could also lead to severe physical injury or death. Follow all safety instructions in this literature and all warning labels that are attached to the equipment.
- Prevailing WH&S regulations must be observed and will take precedence to the safety instructions contained on this manual. Safe work practices and environment must be the paramount importance in the performance of all the service procedures.
- Ensure that unit installation complies with relevant council regulations and building code standards.
- All electrical wiring must be in accordance with current electrical authority regulations and all wiring connections to be as per electrical diagram provided.
- Secure the fans against accidental contact. Beware of pinch point and sharp edges which can cause cutting injury.
- Always wear appropriate PPE, remove any dangling jewellery and protect long hair by wearing a cap.
- Make sure that safety guards and panel covers are always firmly secured and not damaged.
- This appliance is not intended for use by young children or infirm persons unless they have been adequately supervised by a responsible person to ensure that they can use the appliance safely. Young children should be supervised to ensure that they do not play with the appliance.
- Installer must incorporate a means of electrical disconnection (isolator) in the sub mains fixed wiring in accordance with the latest version of the AS/NZS 3000 (also known as Australian Wiring Rules).
- Secure the power cords and control cables that goes in/out the unit.

\*Qualifications required will be appropriate Electrical, Refrigeration and Refrigerant Handling License and Training dependent on local State/Territory regulations.

 **DANGER****Hazardous Voltage - Risk of Electrocutation.**

Turn Off the power from main isolator before proceeding with any service work of the unit. Observe proper LOCK-OUT/TAG-OUT (LOTO) procedures for electrical appliances in order to prevent accidental switching-on of the power supply. Extreme care and caution must be observed should there be a need to work on live circuit.

 **WARNING**

This air conditioning unit contains R-32 refrigerant (CLASS A2L) which is mildly flammable.

Thoroughly read and understand the accompanying **R-32 Safety Guide** for installation and maintenance instructions.

Installation, service, maintenance, repairs and decommissioning of this unit must be performed by a licensed HVAC technician; qualified to handle R-32 refrigerant.

R-32 refrigerant is odorless if the refrigerant gas comes into contact with fire, it may emit a poisonous gas.

Appliance shall be installed, operated and stored in a well ventilated area:

- where the room size corresponds to the room area as specific for operation.
- without continuously operating open flames (for example an operating gas appliance) and ignition sources (for example an operating electric heater).
- away from other potential continuously operating sources that known to cause ignition of R-32 refrigerant.

 **CAUTION****Beware of Rotating Fans!**

Ensure that indoor and outdoor fans are isolated and have come to a complete stand still before servicing the equipment.

Beware of pinch point and sharp edges which can cause cutting injury. Secure the fans against accidental contact.

Always wear appropriate PPE and remove any dangling jewellery and protect long hair by wearing a cap. Ensure that no loose clothing can be caught / entangled in moving parts.

**VISUAL INSPECTION AND WORK ASSESSMENT**

Work areas and conditions must first be assessed and evaluated for any potential hazardous conditions. It is also important to be familiar with the unit parts and components before proceeding with any service task.

## 05. Installation Information

All service technicians handling this unit must be licensed to handle R-32 refrigerant.

**Recover and Recycle Refrigerants**

Never release refrigerant to the atmosphere! It is an offence in Australia to do so. Always recover, recycle and reuse refrigerants. When removing from the system, properly contain and identify refrigerants in its dedicated container for proper disposal and/or storage. Always consider the recycle or reclaim requirements of the refrigerant before beginning the recovery procedures. Obtain a chemical analysis of the refrigerant if necessary. For the recovered refrigerant and acceptable refrigerant quality refer to the existing standards and regulations.

**Refrigerant Handling and Safety**

Consult the refrigerant manufacturer's Material Safety Data Sheet (MSDS) for information on proper handling and to fully understand health, safety, storage and disposal requirements. Use the approved containment vessels and refer to appropriate safety standards. Comply with all applicable transportation standards when shipping refrigerant containers.

### Service Equipment and Recovery Procedures

Always use refrigerant reclaiming equipment in order to minimise refrigerant emissions. Use equipment and methods which will pull the lowest possible system vacuum while recovering and condensing refrigerant. Equipment capable of pulling a vacuum of less than 500 microns is required.

Do not open the system to the atmosphere for service work until refrigerant is fully removed and/or recovered. Perform refrigeration system evacuation, prior to charging, in accordance with AIRAH / IRHACE Refrigerant handling code of practice.

Let the unit stand for 1 hour and with the vacuum not rising above 500 microns. A rise above 500 microns indicates a leak from the system and a leak test is required to locate and repair any leak.

Charge refrigerant into the system only after the equipment does not leak or contain moisture. Take into consideration the correct amount of refrigerant charge specified for the system to ensure efficient unit operations. When charging is complete, reclaim refrigerant from charging lines into an approved refrigerant container. Seal all used refrigerant containers with approved closure devices to prevent unused refrigerant from escaping to the atmosphere. Take extra care to maintain all service equipment directly supporting refrigerant service work such as gauges, hoses, vacuum pumps and recycling equipment.

### INSTALLATION PREPARATION (Pre-Installation considerations)

The following items must be considered before beginning the unit installation:

- Verify the unit capacities and ratings with the unit nameplate.
- Make certain the floor or foundation is level, solid and has sufficient structural strength to support the unit and accessories weight.
- Install anti-vibration rubber (installer to supply) under **all of the unit's feet** to help reduce noise and minimize vibration transfer through the foundation. Ensure that all anti-vibration rubbers are rated to provide stable support without impairing the unit's structural integrity.
- Diameter or width of anti-vibration rubber's must be at least equal to the width of the actual feet to prevent deformation overtime.
- Allow minimum recommended clearances for periodic maintenance and service access.
- Allow sufficient space beside the unit for the outdoor air discharge. Condenser air inlet, located on the coil side of the unit, requires sufficient airflow clearance for the optimum unit performance.
- Note the conditioned supply air and return air location. Ensure sufficient spaces are allocated for these purposes.
- For the connection and location of condensate drain in the unit, refer to the drawings and dimensions section of this manual.
- Wiring connections must be in accordance with the wiring diagram provided with the unit.
- Make sure all wirings are in accordance with local electricity authority regulations and standards.
- Do not install the unit close to an area where there is a danger of fire due to volatile, explosive, flammable and/ or hazardous materials.
- Ensure that spaces around the unit are free from any obstructions for optimum unit performance.
- Installer to ensure correct size/type that main circuit breaker and cable is installed in unit sub-mains to protect the sub-mains and unit wiring.
- Installer to ensure correctly rated residual current device (RCD) is installed as per the latest version of the AS/NZS 3000 (also known as Australian Wiring Rules).

#### NOTE











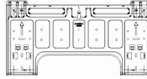

This outdoor unit is designed to match only with ActronAir indoor unit as specified in the Technical Selection Catalogue.

This unit is designed for use with R-32 refrigerant only.

The unit is supplied with factory charged R-32 refrigerant. Be aware of all the relevant regulations concerning the handling of refrigerant.

## 06. Components

The air conditioning system comes with the following components. Use all of the installation parts and accessories to install the air conditioner. Improper installation may result in water leakage, electrical shock, fire or cause the equipment to fail.

Name of Accessories	Quantity	Illustration
Mounting plate	1	
Clip anchor	5	
Mounting plate fixing screw ST3.9 X 25	5	
Remote controller	1	
Fixing screw for remote controller holder ST2.9 x 10	2	
Dry battery AAA.LR03	2	
Seal	1	
Drain joint	1	
Remote control holder	1	
Owner's manual	1	
Installation manual	1	
Remote Controller Operational Manual	1	
Safety Guide	1	

07. Installation Summary

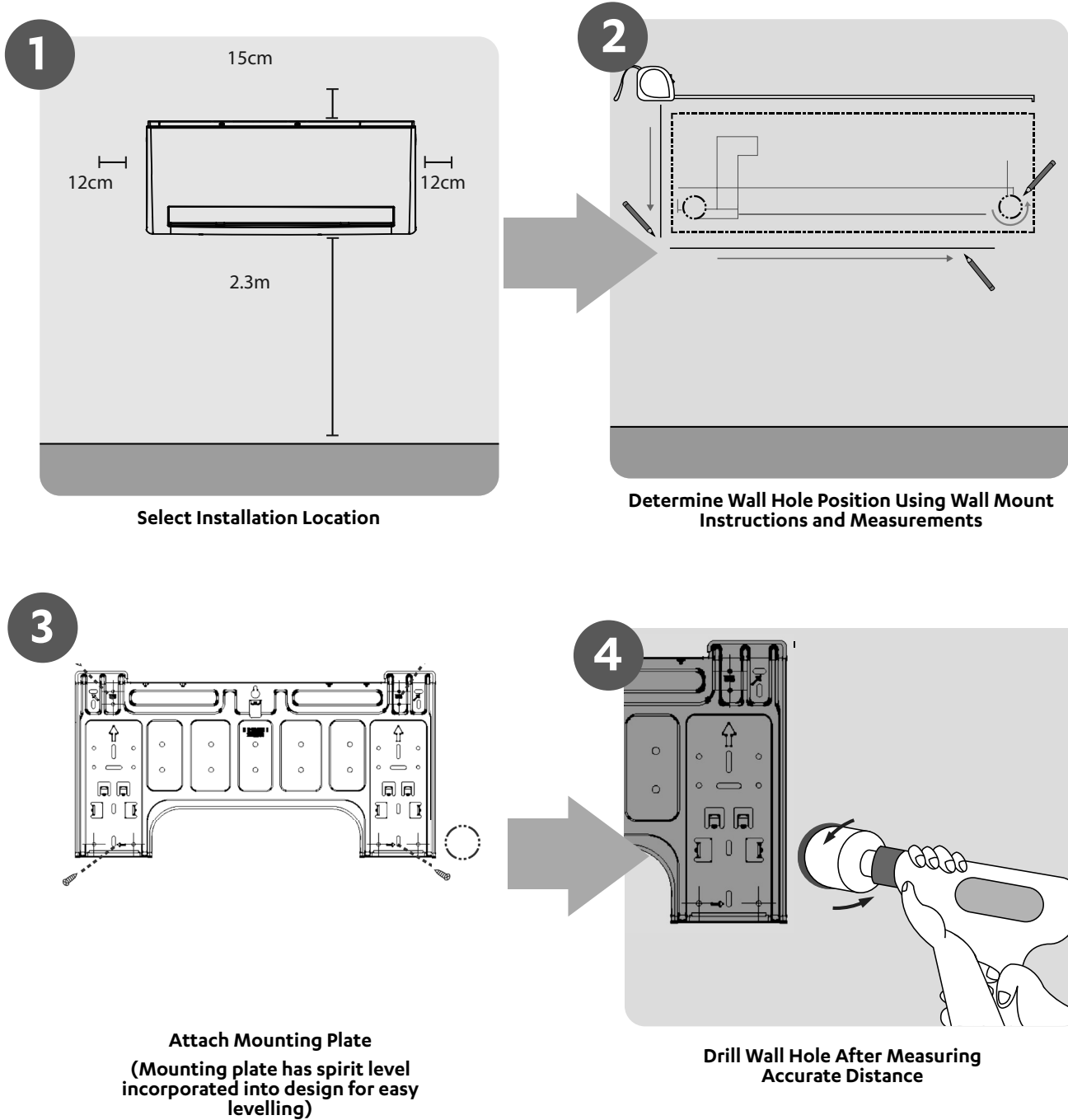



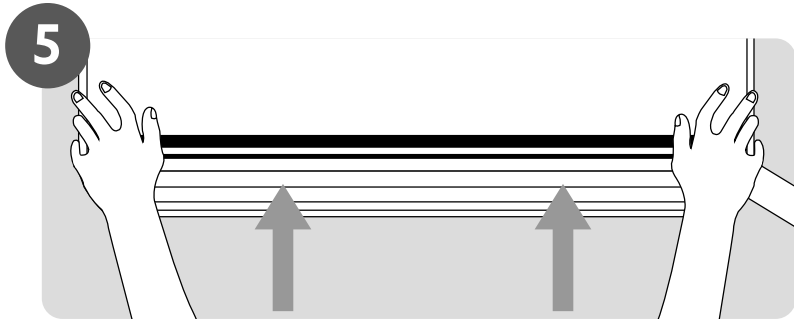

Mount Indoor Unit

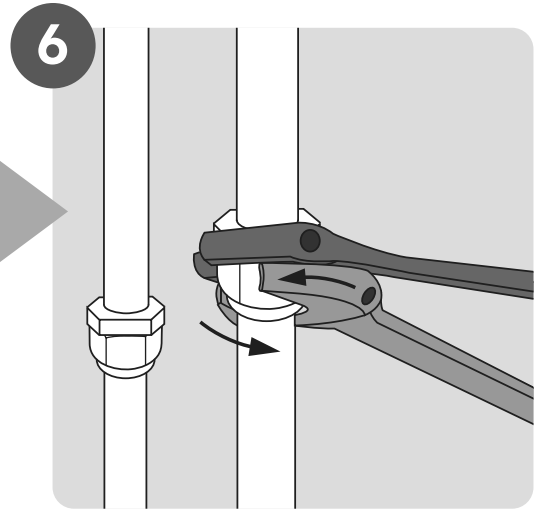

Connect Piping

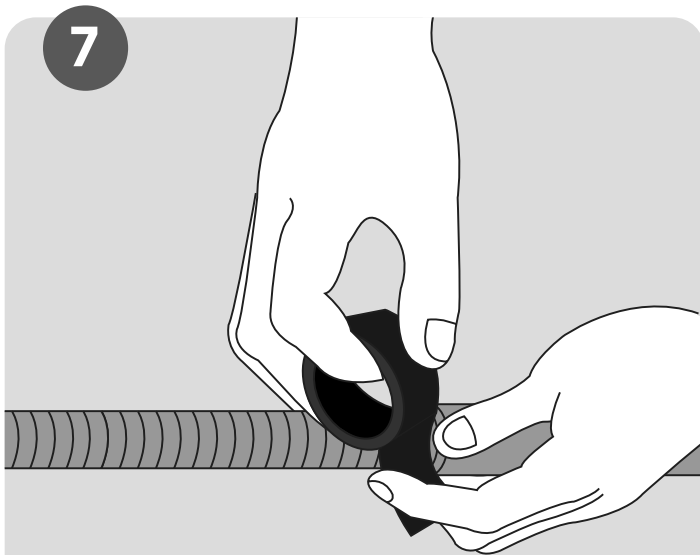

Prepare Drain Hose

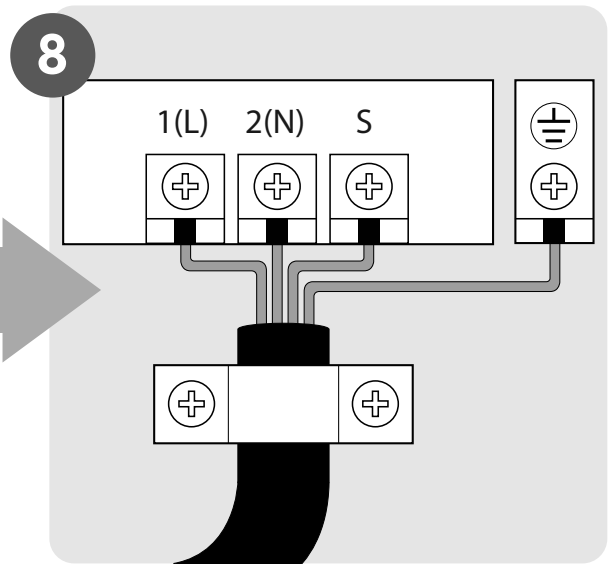

Connect wiring

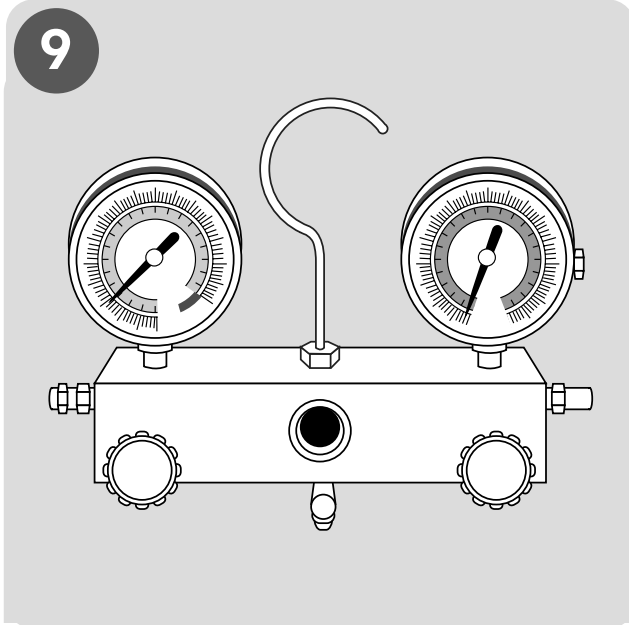

Leak test and evacuate the refrigeration system

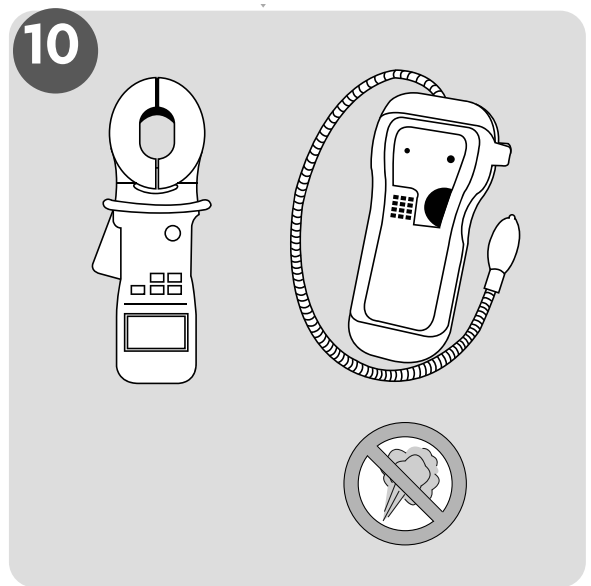
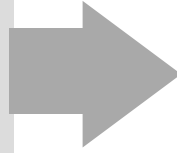

Perform a test run

08. Parts Overview

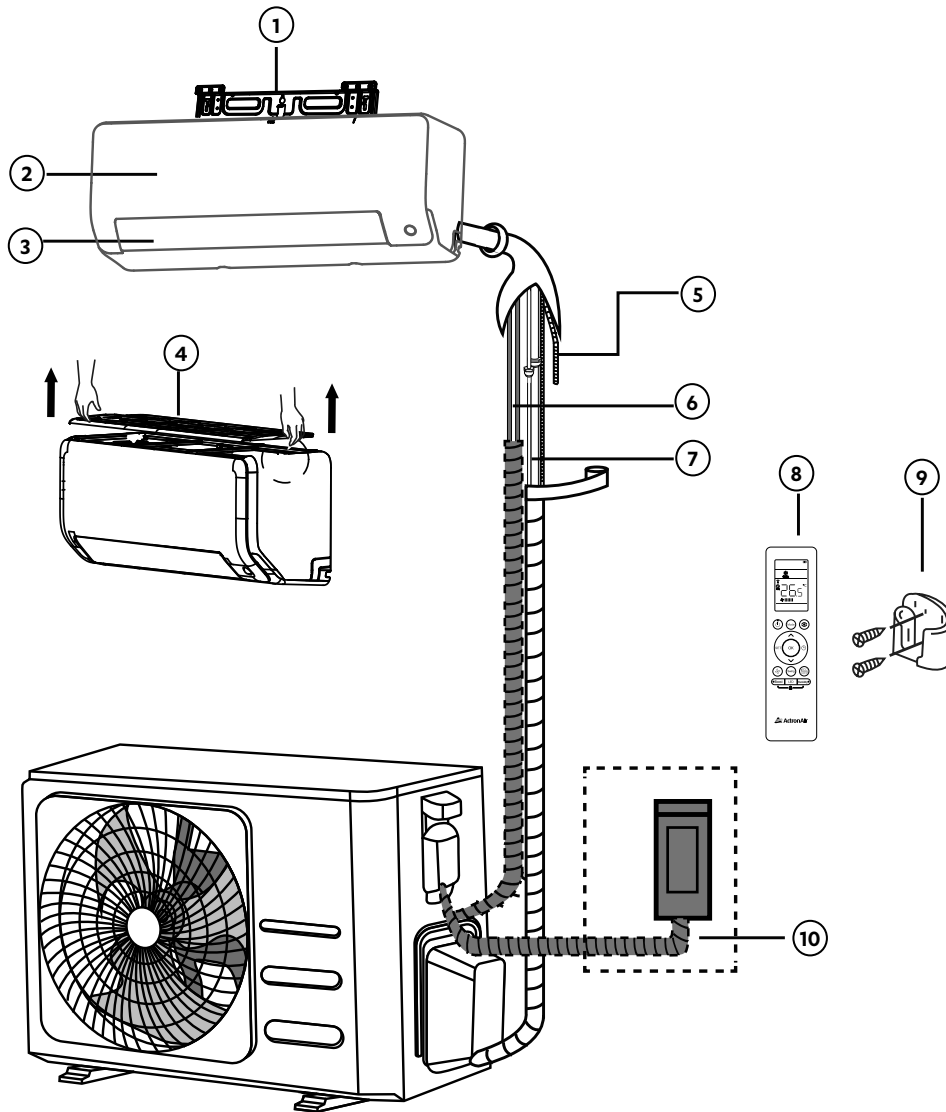

- |   |                     |   |                                      |
|---|---------------------|---|--------------------------------------|
| ① | WALL MOUNTING PLATE | ⑥ | INTERCONNECTING CABLE                |
| ② | FRONT PANEL         | ⑦ | REFRIGERANT PIPING                   |
| ③ | LOUVRE              | ⑧ | REMOTE CONTROL                       |
| ④ | AIR FILTER          | ⑨ | REMOTE HOLDER                        |
| ⑤ | DRAINAGE PIPE       | ⑩ | OUTDOOR UNIT POWER TO MAINS ISOLATOR |

## 09. Indoor Unit Installation

### Installation Instructions

#### NOTE

Before installing the indoor unit, refer to the label on the product box to make sure that the model number of the indoor unit matches the model number of the outdoor unit.

#### Step 1: Select installation location

Before installing the indoor unit, you must choose an appropriate location. The following are the standards that will help you choose an appropriate location for the unit.

#### Proper installation locations meet the following standards:

- Good air circulation
- Convenient drainage
- Noise from the unit will not disturb other people
- Firm and solid—the location will not vibrate
- Strong enough to support the weight of the unit
- A location at least one meter from all other electrical devices (e.g., TV, radio, computer)

#### DO NOT install unit in the following locations:

- Near any source of heat, steam, or combustible gas
- Near flammable items such as curtains or clothing
- Near any obstacle that might block air circulation
- Near the doorway
- In a location subject to direct sunlight

#### NOTE

While choosing a location, you should leave ample room for a wall hole (see step for **Drill wall hole for connective piping**) for the signal cable and refrigerant piping that connect the indoor and outdoor units. The default position for all piping is the right side of the indoor unit (while facing the unit). However, the unit can accommodate piping to both the left and right.

Refer to the following diagram to ensure proper distance from walls and ceiling:

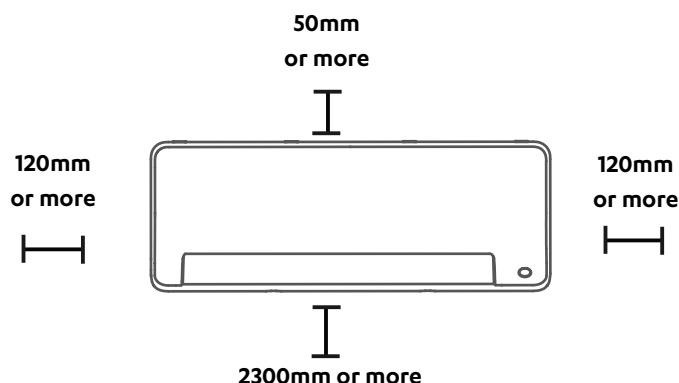

**Step 2: Attach mounting plate to wall**

The mounting plate is the component on which you will mount the indoor unit.

1. Remove the screw that attaches the mounting plate to the back of the indoor unit.
2. Place the mounting plate against the wall in a location that meets the standards in the **Step 1: Select installation location**. (Refer to **Mounting Plate Dimensions** for detailed information on mounting plate sizes.)
3. Drill holes for mounting screws in places that:
  - Have studs and can support the weight of the unit
  - Correspond to screw holes in the mounting plate
4. Secure the mounting plate to the wall with the screws provided.
5. Make sure that mounting plate is flat against the wall.

**NOTE**

If the wall is made of brick, concrete, or similar material, drill 5mm-diameter holes in the wall and insert the sleeve anchors provided. Then secure the mounting plate to the wall by tightening the screws directly into the wall.

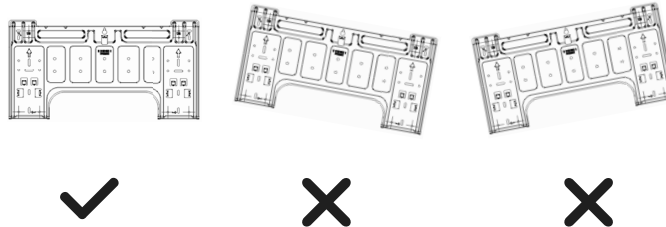
**Correct orientation of mounting plate**

**Step 3: Drill wall hole for connective piping**

You must drill a hole in the wall for refrigerant piping, the drainage pipe, and the signal cable that will connect the indoor and outdoor units.

1. Determine the location of the wall hole based on the position of the mounting plate. Refer to **Mounting Plate Dimensions** to help you determine the optimal position. The wall hole should have a 65mm diameter at least, and at a slightly lower angle to facilitate drainage.
2. Using a 65-mm core drill, drill a hole in the wall. Make sure that the hole is drilled at a slight downward angle, so that the outdoor end of the hole is lower than the indoor end by about 5mm to 7mm. This will ensure proper water drainage.

 **CAUTION**

When drilling the wall hole, make sure to avoid wires, plumbing, and other sensitive components.

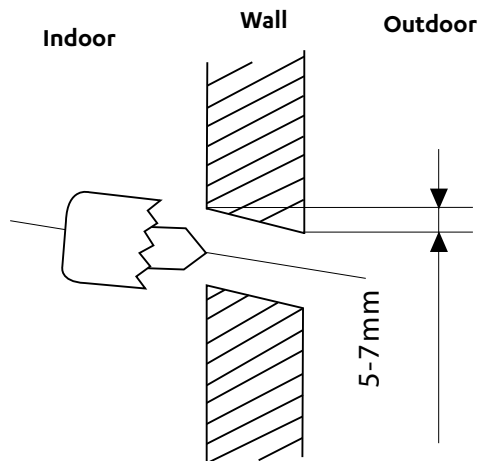

## Mounting Plate Dimensions

Different models have different mounting plates. In order to ensure that you have ample room to mount the indoor unit, the diagrams below show different types of mounting plates along with the following dimensions:

- Width of mounting plate
- Height of mounting plate
- Width of indoor unit relative to plate
- Height of indoor unit relative to plate
- Recommended position of wall hole (both to the left and right of mounting plate)
- Relative distances between screw hole

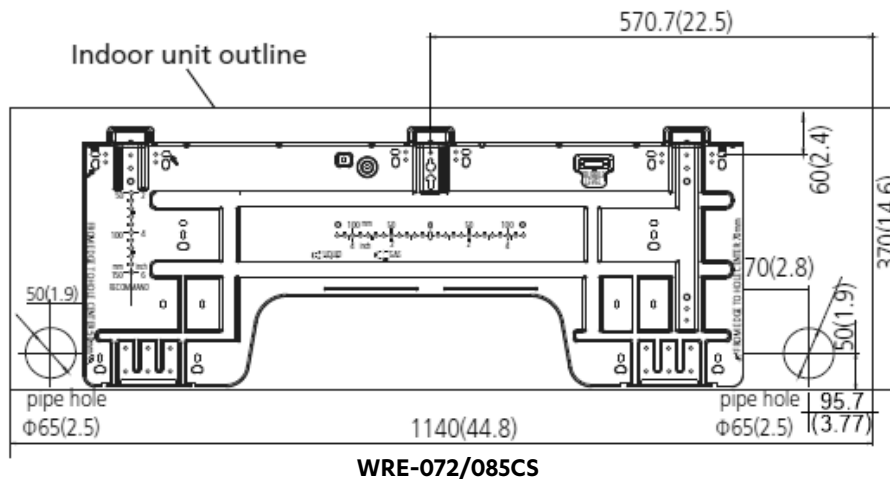
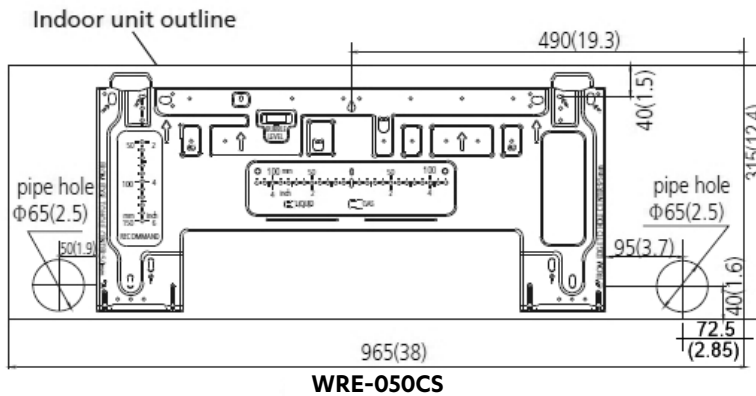
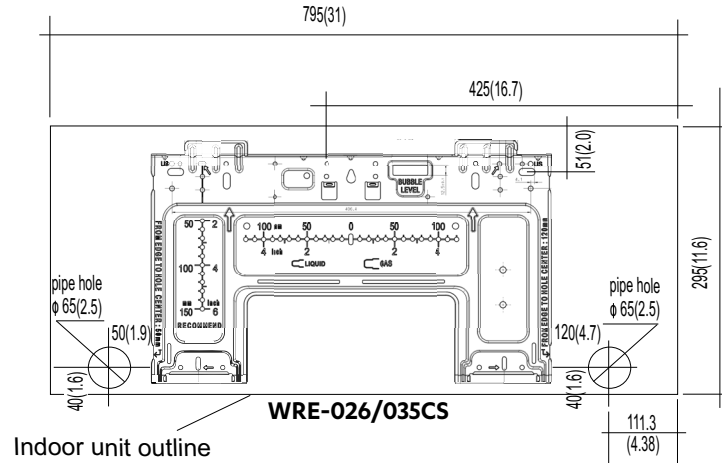

**Step 4: Prepare refrigerant piping**

The refrigerant piping is inside an insulating sleeve attached to the back of the unit. You must prepare the piping before passing it through the hole in the wall. Refer to the **Refrigerant Piping Connection** section of this manual for detailed instructions on pipe flaring and flare torque requirements, technique, etc.

**NOTE**

Refrigerant piping can exit the indoor unit from four different angles:

- Left-hand side
- Left rear
- Right-hand side
- Right rear

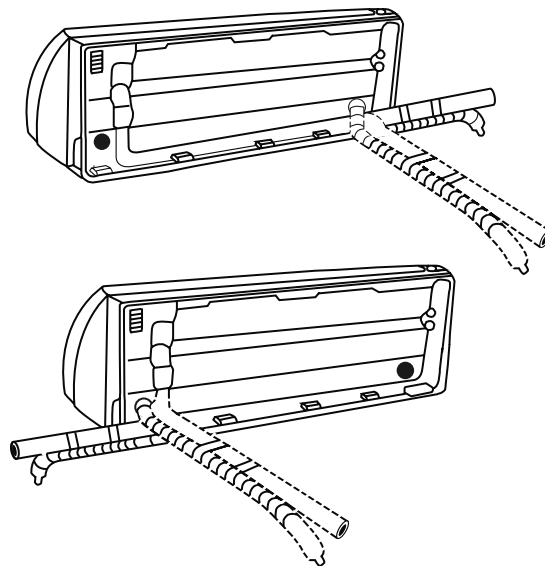
**⚠ CAUTION**

Be extremely careful not to dent or damage the piping while bending them away from the unit. Any dents in the piping will affect the unit's operation.



**Step 5: For piping run outside the wall cavity, do the following: (if piping is run inside the wall cavity, proceed to Step 6.)**

1. Based on the position of the wall hole relative to the mounting plate, choose the side from which the piping will exit the unit.
2. If the wall hole is behind the unit, keep the knock-out panel in place. If the wall hole is to the side of the indoor unit, remove the plastic knock-out panel from that side of the unit. This will create a slot through which your piping can exit the unit. Use needle nose pliers if the plastic panel is too difficult to remove by hand.

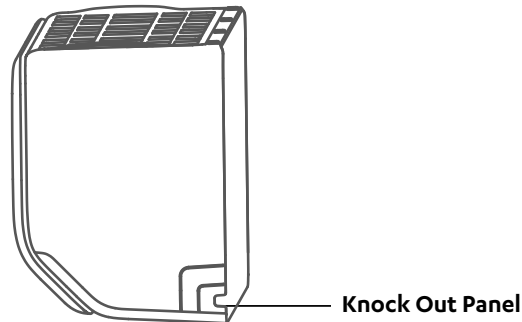

3. Use scissors to cut down the length of the insulating sleeve to reveal about 40mm of the refrigerant piping. This serves two purposes:
  - To facilitate the **Refrigerant Piping Connection** process.
  - To facilitate Gas Leak Checks and enable you to check for dents.
4. Connect the indoor unit's refrigerant piping to the connective piping that will join the indoor and outdoor units. Refer to the **Refrigerant Piping Connection** section for detailed instructions.
5. Based on the position of the wall hole relative to the mounting plate, determine the necessary angle of your piping.
6. Grip the refrigerant piping at the base of the bend.
7. Slowly, with even pressure, bend the piping towards the hole. Do not dent or damage the piping during the process.

**Step 6: Hook the indoor unit on the mounting plate:**

Keep in mind that the hooks on the mounting plate are smaller than the holes on the back of the unit. In that case, you don't have ample room to connect embedded pipes to the indoor unit, the unit can be adjusted left or right by about 30-50mm, depending on the model.

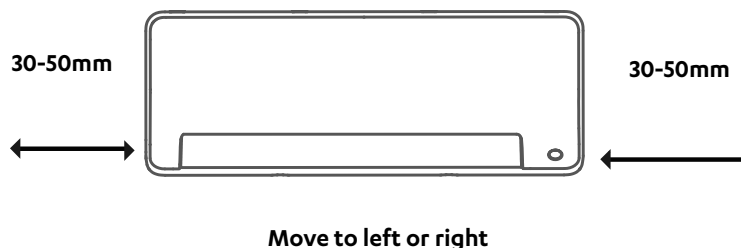

## Step 7: Refrigerant piping:

1. Open and fix the position of the panel using the latch. Unscrew and hold both sides of the lower panel from the places marked **PULL**. Pull it upwards to release the buckles and take the lower panel down.

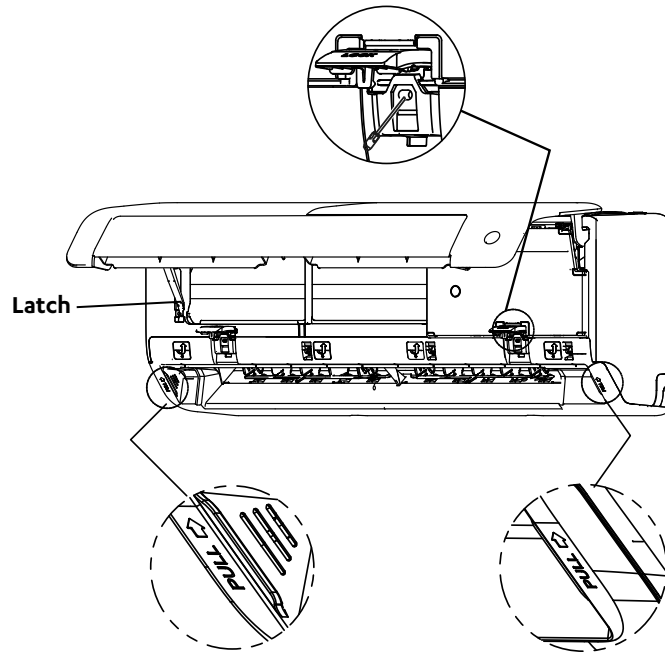

2. Use the holder in the mounting plate to prop up the unit, giving you enough room to connect the refrigerant piping, signal cable, and drain hose.

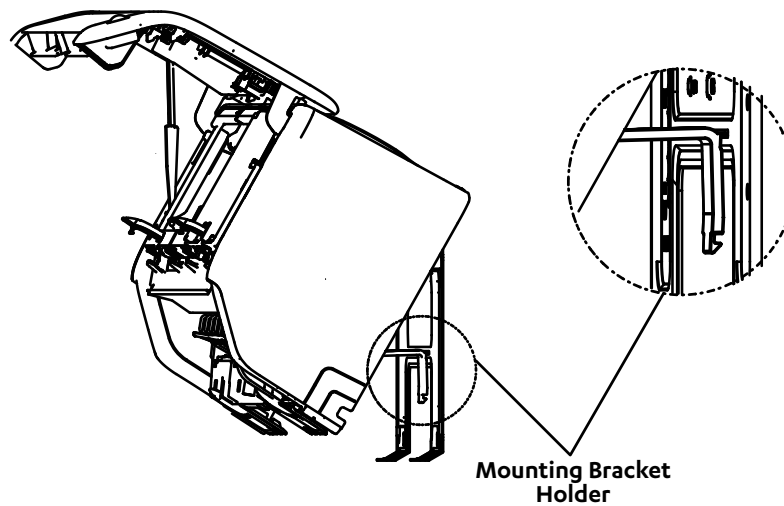

3. Connect drain hose and refrigerant piping (refer to **Refrigerant Piping Connection** section for instructions).
4. Keep pipe connection point exposed to perform the leak test (refer to **Electrical Checks and Leak Checks** section).
5. After the leak test, wrap the connection point with insulation tape.
6. Remove the bracket or wedge that is propping the unit up.
7. Using even pressure, push down on the bottom half of the unit. Keep pushing down until the unit snaps onto the hooks along the bottom of the mounting plate.

## Step 8: Connect drain hose

By default, the drain hose is attached to the left hand side of unit (when you're facing the back of the unit). However, it can also be attached to the right-hand side.

1. To ensure proper drainage, attach the drain hose on the same side that your refrigerant piping exits the unit.
2. Attach drain hose extension (purchased separately) to the end of drain hose.
3. Wrap the connection point firmly with Teflon tape to ensure a good seal and to prevent leaks.
4. For the portion of the drain hose that will remain indoors, wrap it with foam pipe insulation to prevent condensation.
5. Remove the air filter and pour a small amount of water into the drain pan to make sure that water flows from the unit smoothly.

### NOTE

To prevent unwanted leaks double check that the unused drain hole is plugged into the rubber plug.

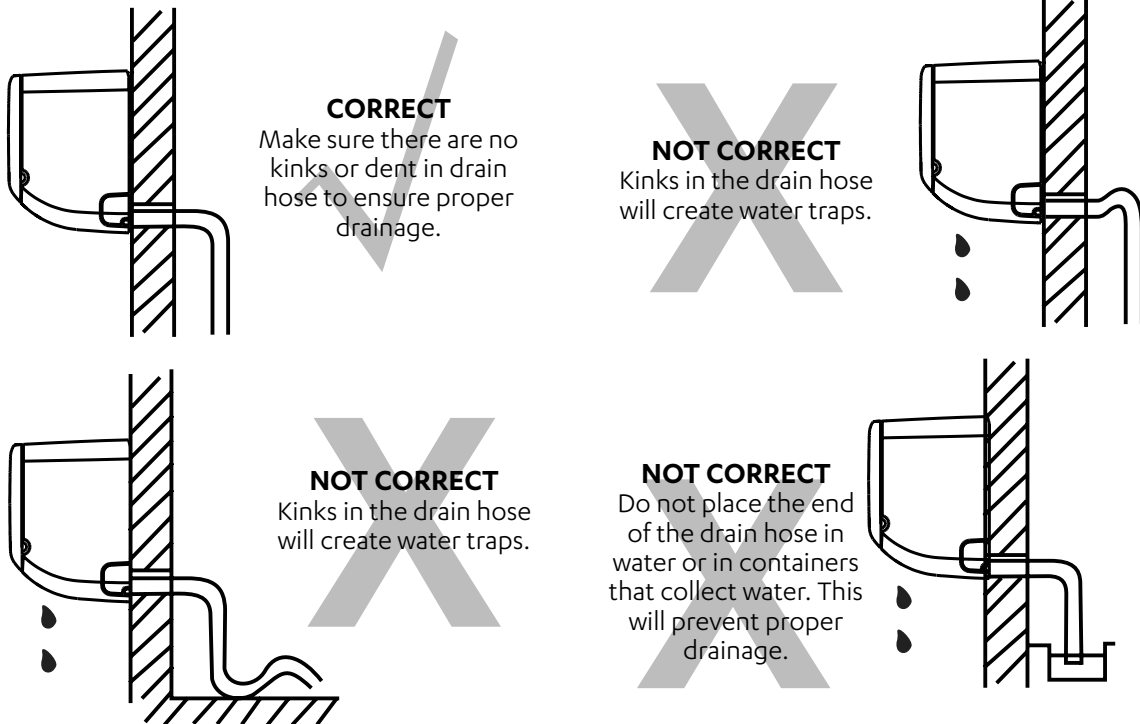

 **CAUTION**

Before performing any electrical work, read the following regulations:

1. All wiring must comply with local and national electrical codes, and must be installed by a licensed electrician.
2. All electrical connections must be made according to the Electrical Connection Diagram located on the panels of the indoor and outdoor units.
3. Power voltage should be within Australian Standards 230VAC (+10%, -6%) 50Hz. Insufficient power supply can cause malfunction, electrical shock, or fire.
4. Correct sized circuit breaker must be installed.
5. Only connect the unit to an individual final sub-circuit. Do not connect another appliance to that sub-circuit.
6. Make sure to properly earth the air conditioner.
7. Every wire must be firmly connected. Loose wiring can cause the terminal to overheat, resulting in product malfunction and possible fire.
8. Do not let wires touch or rest against refrigerant tubing, the compressor, or any moving parts within the unit.

 **WARNING**

Always make sure that all power supply, including remote controls, are disconnected before performing maintenance. Observe proper LOCK-OUT / TAG-OUT (LOTO) procedures to ensure that power cannot be inadvertently energised.

**Step 9: Connect interconnecting cable**

The signal cable enables communication and power between the indoor and outdoor units. Choose the right cable size before preparing for connection.

**NOTE**

The size of the power supply cable, signal cable, fuse, and switch needed is determined by the maximum current of the unit. The maximum current is indicated on the nameplate located on the side panel of the unit. Refer to this nameplate to choose the right cable and refer to AS3000 and local wiring rules and etc.

**NOTE**

The air conditioner's circuit board (PCB) is designed with a fuse to provide overcurrent protection. The specifications of the fuse are printed on the circuit board, such as: T3.15A/250VAC, T5A/250VAC, etc.

1. Prepare the cable for connection:
  - Using wire strippers, strip the outer insulation from both ends of signal cable to reveal about 40mm of the wires inside.
  - Strip the inner insulation from the ends of the wires.
  - Using wire crimper, crimp u-type lugs on the ends of the wires.
2. Open front panel of the indoor unit by loosening the screws as shown in **Step 7**, which provides space for wiring connection.
3. Open the wire box cover to connect the cable.

 **WARNING**

All wiring must be performed strictly in accordance with the wiring diagram located on the inside of the indoor unit's wire cover.

1. Unscrew the cable clamp below the terminal block and place it to the side.
2. Facing the back of the unit, remove the plastic panel on the bottom left-hand side.
3. Feed the signal wire through this slot, from the back of the unit to the front.
4. Facing the front of the unit, match the wire colors with the labels on the terminal block, connect the u-lug and and firmly screw each wire to its corresponding terminal.

## CAUTION

### DO NOT MIX UP MAINS POWER AND SIGNAL WIRES

This is dangerous, and can cause the air conditioning unit to malfunction.

1. After checking to make sure every connection is secure, use the cable clamp to fasten the signal cable to the unit. Screw the cable clamp down tightly.
2. Replace the wire cover on the front of the unit, and the plastic panel on the back.

## NOTE

The wiring connection process may differ slightly between units.

### Step 10: Wrap piping and cables

Before passing the piping, drain hose, and the signal cable through the wall hole, you must bundle them together to save space, protect them, and insulate them.

1. Bundle the drain hose, refrigerant pipes, and interconnecting cable.

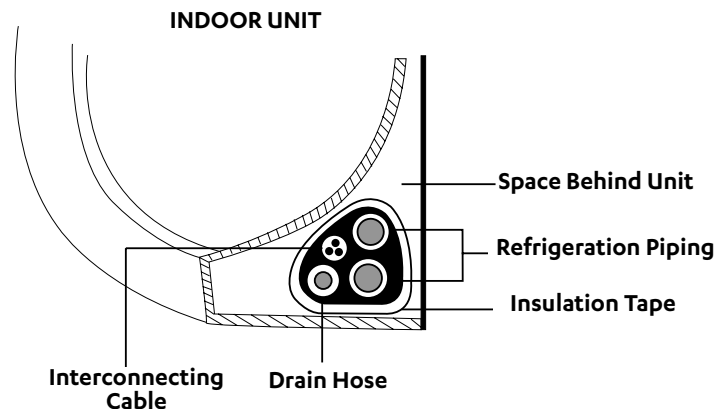

## NOTE

Make sure that the drain hose is at the bottom of the bundle. Putting the drain hose at the top of the bundle can cause the drain pan to overflow, which can lead to fire or water damage.

2. Using adhesive vinyl tape, attach the drain hose to the underside of the refrigerant pipes.
3. Using insulation tape, wrap the signal wire, refrigerant pipes, and drain hose tightly together. Double-check that all items are bundled.

## NOTE

When wrapping the bundle, keep the ends of the piping unwrapped. You need to access them to test for leaks at the end of the installation process.

**Step 11: Mount indoor unit**

1. If you have already passed the refrigerant piping through the hole in the wall, proceed to point 4.
2. Otherwise, double-check that the ends of the refrigerant pipes are sealed to prevent dirt or foreign materials from entering the pipes.
3. Slowly pass the wrapped bundle of refrigerant pipes, drain hose, and signal wire through the hole in the wall.
4. Hook the top of the indoor unit on the upper hook of the mounting plate.
5. Check that unit is hooked firmly on mounting by applying slight pressure to the left and right-hand sides of the unit. The unit should not jiggle or shift.
6. Using even pressure, push down on the bottom half of the unit. Keep pushing down until the unit snaps onto the hooks along the bottom of the mounting plate.
7. Again, check that the unit is firmly mounted by applying slight pressure to the left and the right-hand sides of the unit.

## 10. Outdoor Unit Installation

**NOTE**

Before installing the outdoor unit, refer to the label on the product box to make sure that the model number of the outdoor unit matches the model number of the indoor unit.

Before installing the outdoor unit, you must choose an appropriate location. The following are standards that will help you choose an appropriate location for the unit.

Proper installation locations meet the following standards:

- Good air circulation
- Convenient drainage
- Sufficient clearances for periodic maintenance and service access.
- Noise from the unit will not disturb other people
- Firm, level and solid—the location will not vibrate and strong enough to support the weight of the unit
- Fit anti-vibration rubber (not provided with the unit) under the unit feet to reduce noise and vibration transfer through the foundation. Make sure that vibration rubbers are rated to provide sound and stable support without impairing the unit's structural integrity.

DO NOT install unit in the following locations:

- Near any source of heat, steam, or combustible gas
- Near flammable items such as curtains or clothing
- Near any obstacle that might block air circulation
- Near the doorway
- In a location subject to direct sunlight

## Step 1: Select installation location

Before installing the outdoor unit, you must choose an appropriate location. The following are standards that will help you choose an appropriate location for the unit.

Proper installation locations meet the following standards:

- ☑ Meets all spatial requirements
- ☑ Good air circulation and ventilation
- ☑ Firm and solid—the location can support the unit and will not vibrate
- ☑ Noise from the unit will not disturb others
- ☑ Protected from prolonged periods of direct sunlight or rain

### NOTE

#### DO NOT INSTALL THE UNIT IN THE FOLLOWING LOCATIONS:

- Near an obstacle that will block air inlets and outlets.
- Near a public street, crowded areas, or where noise from the unit will disturb others.
- Near animals or plants that will be harmed by hot air discharge.
- Near any source of combustible gas.
- In a location that is exposed to large amounts of dust.
- In a location exposed to excessive amounts of salty air.

### NOTE

If the unit is exposed to heavy wind:

Install unit so that air outlet fan is at a 90° angle to the direction of the wind. If needed, build a barrier in front of the unit to protect it from extremely heavy winds while maintaining service clearances.

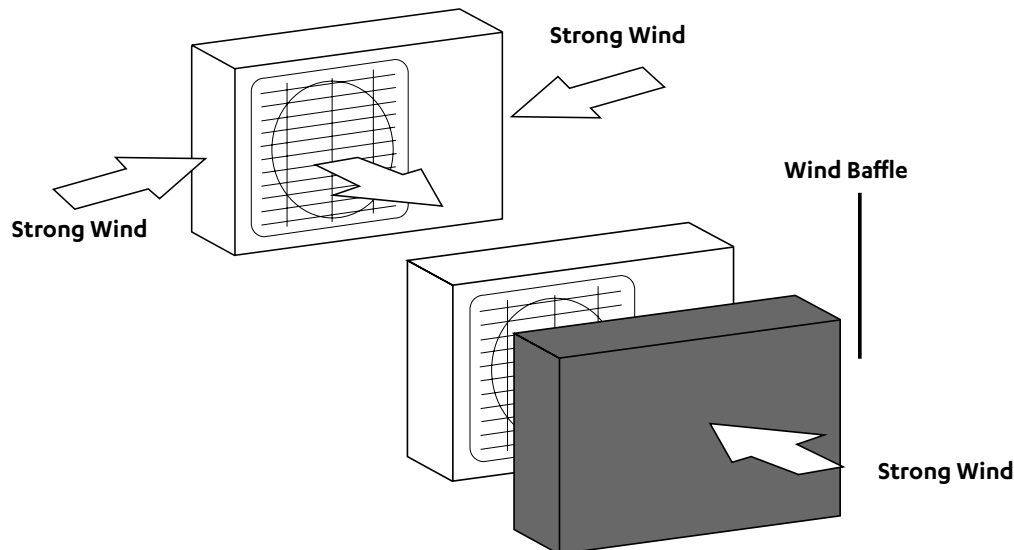

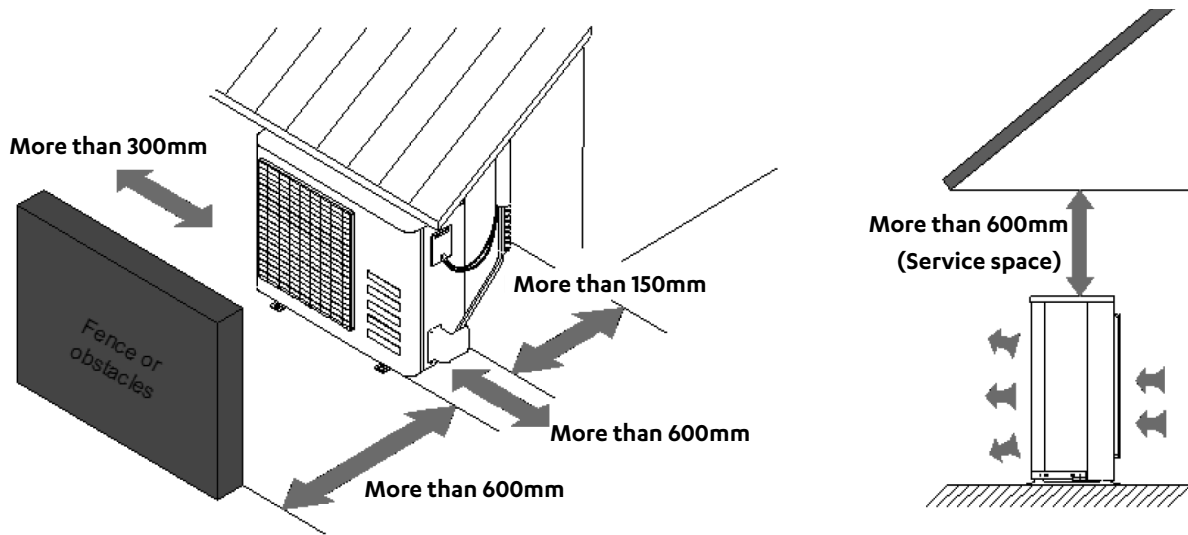

## Step 2: Install drain joint

Outdoor unit require a drain joint. Before bolting the outdoor unit in place, you must install the drain joint at the bottom of the unit.

The drain joint comes with a rubber seal, do the following:

1. Fit the rubber seal on the end of the drain joint that will connect to the outdoor unit.
2. Insert the drain joint into the hole in the base pan of the unit.
3. Rotate the drain joint 90° until it clicks in place facing the front of the unit.
4. Connect a drain hose extension (not included with product) to the drain joint to redirect water from the unit during heating mode.

### NOTE

In cold climates, make sure that the drain hose is as vertical as possible to ensure swift water drainage. If water is draining slowly, it can freeze in the hose and flood the unit.





### Step 3: Anchor outdoor unit

The outdoor unit can be anchored to the ground or to a wall-mounted bracket.

#### NOTE

The following is a list of different outdoor unit sizes and the distance between their mounting feet. Prepare the installation base of the unit according to the dimensions below.

Model Number	Outdoor Unit Dimensions (mm) W x H x D	Mounting Dimensions	
		Distance A (mm)	Distance B (mm)
WRC-026CS WRC-035CS	805 x 554 x 333	511	317
WRC-050CS WRC-072CS WRC-085CS	890 x 673 x 342	663	348

When installing the unit on ground level, ensure it is sufficiently fastened to prevent movement and vibration. it is recommended to install vibration rubbers underneath the feet (not supplied).

#### WARNING

When drilling into concrete, eye protection is recommended at all times.

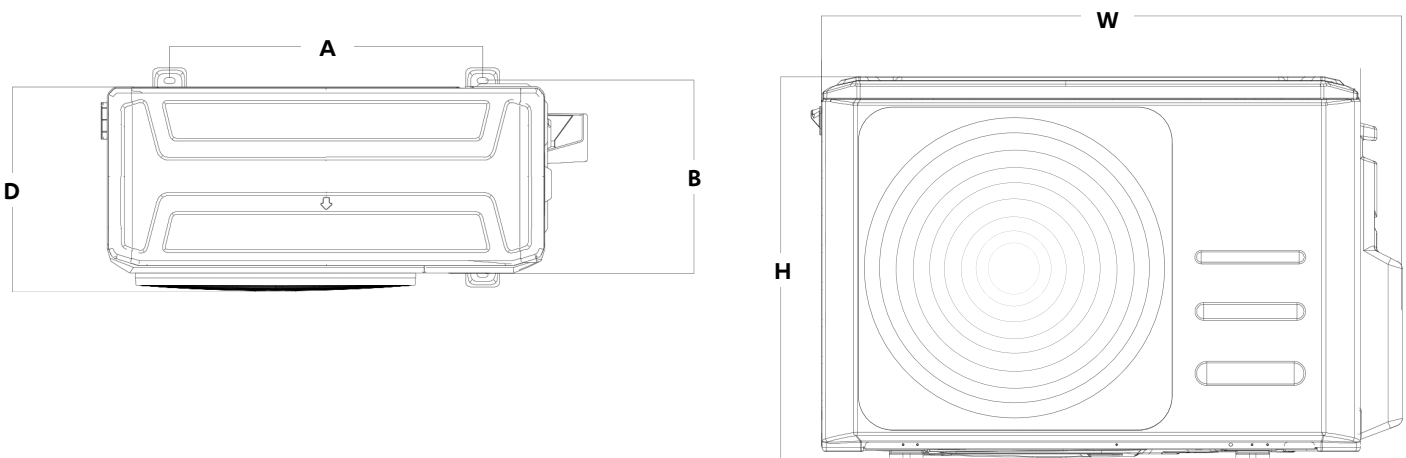

If you will install the unit on a wall-mounted bracket, do the following:

 **CAUTION**

- Before installing a wall-mounted unit, make sure that the wall is made of solid brick, concrete, or of similarly strong material. The wall must be able to support at least four times the weight of the unit.
- Mounting unit on brackets is at the discretion of the installing contractor - it must be fastened and secured prior to operation.

**NOTE**

If allowed, you can install the wall-mounted unit with rubber gaskets to reduce vibrations and noise.

**Step 4: Connect signal and power cables**

The outside unit's terminal block is protected by an electrical wiring cover on the side of the unit. A comprehensive wiring diagram is printed on the inside of the wiring cover.

 **WARNING**

All wiring must be performed strictly in accordance with the wiring diagram located inside the outdoor units' wire cover.

1. Unscrew the electrical wiring cover and remove it.
2. Unscrew the cable clamp below the terminal block and place it to the side.
3. Match the wire colors/labels with the labels on the terminal block, and firmly screw the u-lug of each wire to its corresponding terminal.
4. After checking to make sure every connection is secure, create a drip loop to prevent rain water from flowing into the terminal.
5. Using the cable clamp, fasten the cable to the unit. Screw the cable clamp down tightly.
6. Terminate unused wires. Arrange them so that they do not touch any electrical or metal parts.
7. Replace the wire cover on the side of the unit, and screw it in place.

## 11. Refrigeration Piping Connection

Outdoor Model Indoor Model		WRC-026CS WRE-026CS	WRC-035CS WRE-035CS	WRC-050CS WRE-050CS	WRC-072CS WRE-072CS	WRC-085CS WRE-085CS
Minimum Field Pipe Length - (m)		3	3	3	3	3
Maximum Field Pipe Length - (m)		25	25	30	50	50
Maximum Vertical		10	10	20	25	25
Field Pipe Size	Liquid Pipe - mm (inch)	6.35 (1/4)	6.35 (1/4)	6.35 (1/4)	9.52 (3/8)	9.52 (3/8)
	Gas Pipe - mm (inch)	9.52 (3/8)	9.52 (3/8)	12.7 (1/2)	15.9 (5/8)	15.9 (5/8)
Outdoor Unit	Liquid Pipe - mm (inch)	6.35 (1/4)	6.35 (1/4)	6.35 (1/4)	9.52 (3/8)	9.52 (3/8)
	Gas Pipe - mm (inch)	9.52 (3/8)	9.52 (3/8)	12.7 (1/2)	15.9 (5/8)	15.9 (5/8)
Indoor Unit	Liquid Pipe - mm (inch)	6.35 (1/4)	6.35 (1/4)	6.35 (1/4)	9.52 (3/8)	9.52 (3/8)
	Gas Pipe - mm (inch)	9.52 (3/8)	9.52 (3/8)	12.7 (1/2)	15.9 (5/8)	15.9 (5/8)

### NOTE

Ensure that the length of the refrigerant pipe, the number of bends, and the drop height between the indoor and outdoor units meets the requirements shown in above table.

#### Refrigerant Piping Connection Instructions:

1. Cut the connecting pipes according to required length.
2. Remove burrs in the pipe. Burrs can affect the air-tight seal of refrigerant piping connections.
3. Place flare nuts on both ends of pipe. Flare each end of connecting pipes.

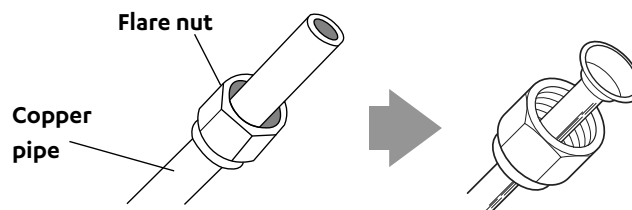

4. Connect the pipe to indoor and outdoor unit. Apply a thin coat of refrigeration oil to the flared end of the pipe. Tighten the flare nuts using a spanner and torque wrench.

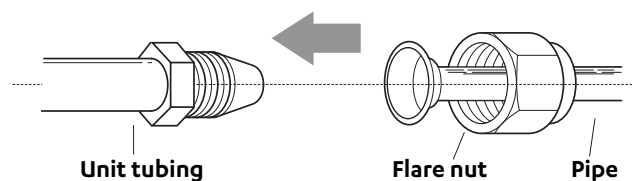

Pipe Flare Dimension and Tightening Torque Guide				
Pipe Size	Tightening Torque	Flare Dimension (A)		Flare Shape
		Min (mm)	Max (mm)	
ø 6.35	18 - 20 Nm	8.3	8.7	
ø 9.52	32 - 39 Nm	13.2	13.5	
ø 12.7	49 - 59 Nm	16.2	16.5	
ø 16	57 - 71 Nm	19.2	19.7	



### CAUTION

- Ensure to wrap insulation around the piping. Direct contact with the bare piping may result in burns or frostbite.
- Make sure the pipe is properly connected. Over tightening may damage the bell mouth and under tightening may lead to leakage.

### Instructions for Connecting Piping to Outdoor Unit

1. Unscrew the valve cover on the side of the outdoor unit.

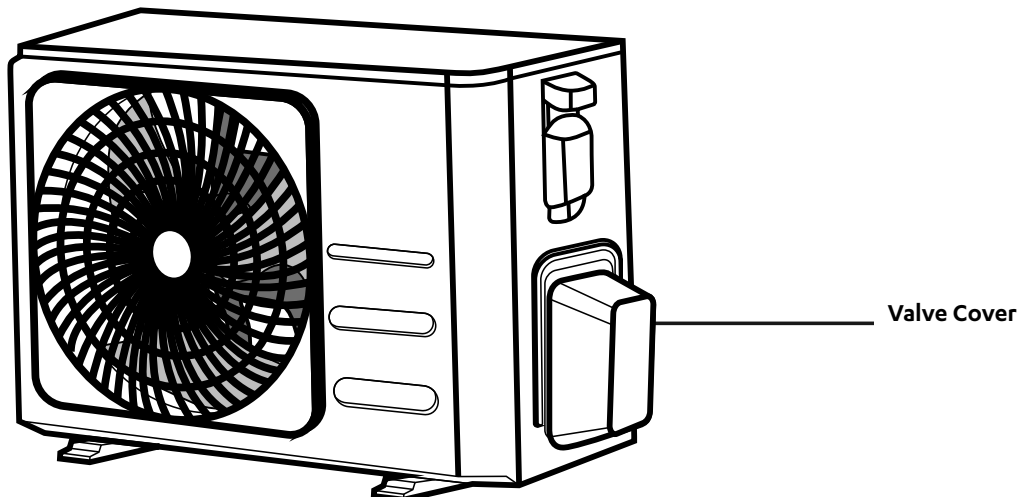

Remove protective caps from ends of valves.

2. Align flared pipe end with each valve, and tighten the flare nut as tightly as possible by hand.
3. Using a spanner, grip the body of the valve. Do not grip the nut that seals the service valve.

### NOTE

USE SPANNER TO GRIP MAIN BODY OF VALVE. Torque from tightening the flare nut can snap off other parts of valve.

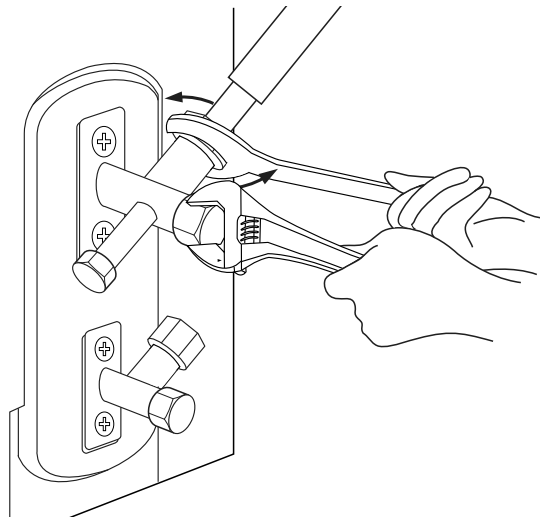

4. While firmly gripping the body of the valve, use a torque wrench to tighten the flare nut according to the correct torque values.
5. Loosen the flaring nut slightly, then tighten again.
6. Repeat Steps 3 to 6 for the remaining pipe.

**⚠ CAUTION**

If the indoor unit is installed at a higher position than the outdoor unit, there is a chance that oil may flow into the compressor. This may cause liquid compression or deterioration of oil return. Use oil traps in the gas piping to prevent this. An oil trap should be installed every 10m in the vertical suction line riser.

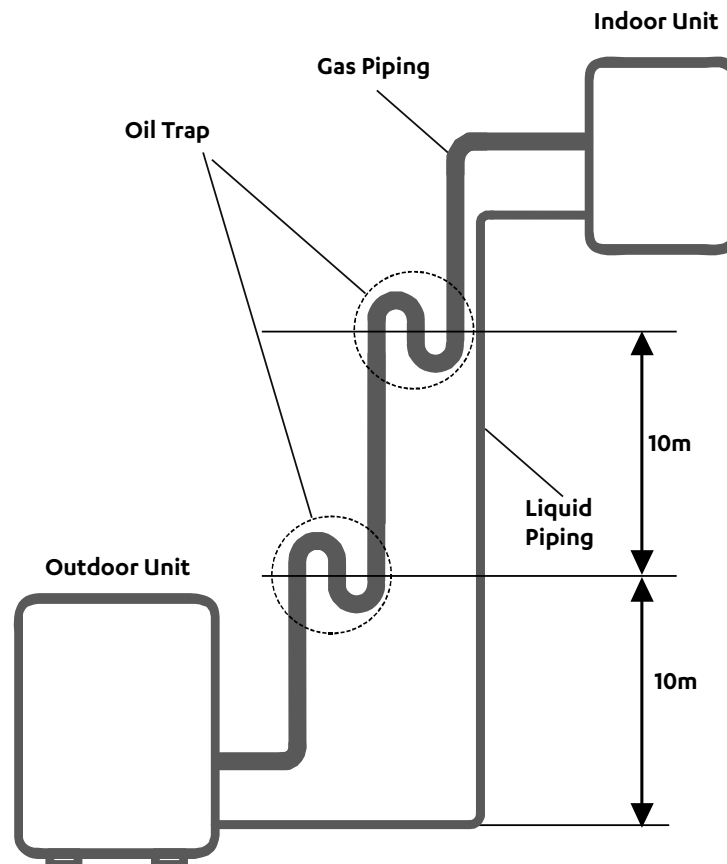

## ⚠ CAUTION

If the outdoor unit is installed at a higher position than the indoor unit, it is recommended that the vertical suction risers not be upsized. Proper oil return to the compressor should be maintained with suction gas velocity. If velocities drop below 7.62 m/s, oil return will be decreased. An oil trap should be installed every 6m of vertical suction line riser.

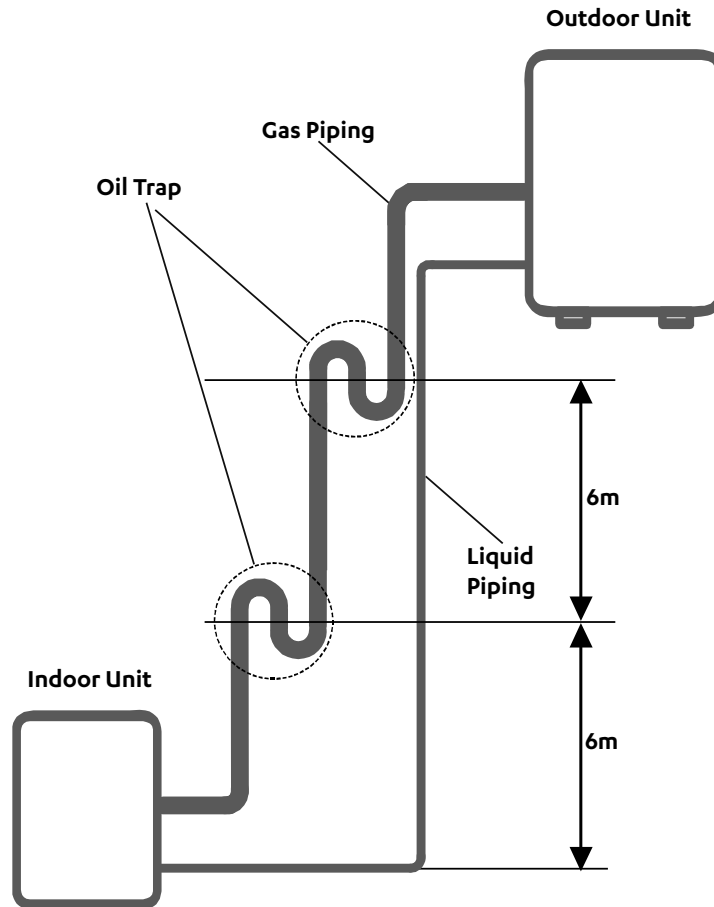

## 12. Wiring

### ⚠ WARNING

- Be sure to isolate the power supply before working on the unit.
- All electrical wiring must be done according to local and national regulations.
- Electrical wiring must be done by qualified technician. Improper connections may cause electrical malfunction, injury and fire.
- Connect the power cable to the terminals and fasten it with the clamp. Unsecured connection may cause fire.
- Make sure that all wiring is done correctly and the control board cover is properly installed. Failure to do so can cause overheating at the connection points, fire, and electrical shock.

### ⚠ CAUTION

- Make sure you earth the unit. Improper earthing may cause electrical shock.
- **DO NOT** connect the unit with the power source until all wiring and piping is completed.
- Make sure that you do not cross your electrical wiring with your signal wiring, as this can cause distortion and interference or unit malfunction.

**Follow these instructions to prevent distortion when the compressor starts:**

- The unit must be connected to its individual sub-circuit. Ensure sub-circuit mains are of adequate size to ensure minimal voltage drop at supply terminals.
- No other equipment should be connected to the same sub-circuit as the air conditioning unit.
- The unit's power information can be found on the rating sticker on the product.

**NOTE**

The air conditioners circuit board (PCB) is designed with a fuse to provide overcurrent protection. The specifications of the fuse are printed on the circuit board, such as: T5A/250VAC, T10A/250VAC, etc.

**Multi-Function Board**

The installation of a multi-function board allows the connection of the following options:

- Remote ON/OFF
- Wired Controller (WC-02)
- Alarm relay output

**Remote On/off**

To use, remote On/Off connect wiring and switch cross CN46 and remove jumper wire that is currently in the terminals. Remote on/off will work by the following two options:

DIP switch F2: OFF/OFF

Current Running Operation	CN46	Operation	CP
Unit ON	Open	OFF	CP
	Closed	No Change	No CP
Unit OFF	Open	No Change	CP
	Closed	ON Last Setting	No CP

DIP switch F2: ON/ON

Current Running Operation	CN46	Operation	CP
Unit ON	Open	OFF	No CP
	Closed	No Change	No CP
Unit OFF	Open	No Change	No CP
	Closed	ON Auto 24°C	No CP

CP – No Control Operation

No CP – Remote/Wired controller operation

N/O and N/C can be reversed by adjusting DIP switches. See wiring diagram for DIP switch settings.

### Wired Controller

Wired controller allows the functions of scheduling on the wall hung split system via connection to multi-function board CN42 and CN41. See wiring diagram for terminal connection locations.

### Alarm Relay Output

Connection terminal CN45 on the multi-function board allows for alarm relay output, this must be 24VAC or DC and limited to 0.5A max. CN45 Relay will close during any error operation which will cause the unit to stop or during OFF operation. See wiring diagram for terminal connection locations.

## 12.01. Outdoor Unit Wiring

### WARNING

Before performing any electrical or wiring work, isolate and LOCK-OUT/TAG-OUT (LOTO) power to the air conditioning unit.

1. Prepare the cable for connection
  - Ensure the correct size cable size has been selected, as per specifications.
  - Using wire strippers, strip the rubber jacket from both ends of signal cable.
  - Strip the insulation from the ends of the wires.
  - Using a wire crimper, crimp fork-lugs on the ends of the wires.

### NOTE

While connecting the wires, please strictly follow the wiring diagram (found inside the electrical box cover).

2. Remove the electric cover of the outdoor unit.

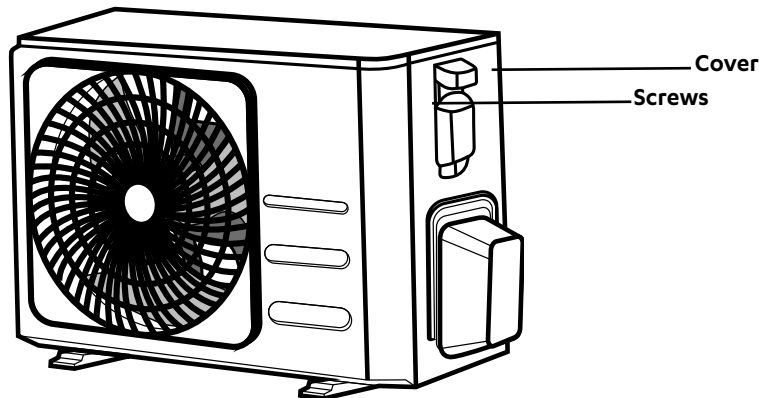

3. Connect the fork-lugs to the terminals. Match the wire colours / labels with the labels on the terminal block, and firmly screw the lug of each wire to its corresponding terminal.
4. Clamp down the cable with designated cable clamp.
5. Reinstall the cover of the electric control box.



## 12.02. Indoor Unit Wiring

1. Prepare the cable for connection
  - Using wire strippers, strip the outer insulation from both ends of signal cable.
  - Strip the insulation from the ends of the internal wires.
  - Using a wire crimper, crimp fork-lugs on the ends of the wires.
2. Open front panel of the indoor unit and loosen the screws.
3. Open the control box cover to connect the cable.
4. Connect the fork-lugs to the terminals. Match the wire colors/labels with the labels on the terminal block, and firmly screw the lug of each wire to its corresponding terminal. Refer to the Wiring Diagram located on the cover of the control box.
5. Clamp down cable with the designated cable clamp to secure it in place. The cable should not be loose, and should not pull on the lugs.
6. Close the control box cover and screw back to the unit.
7. Close the front panel.

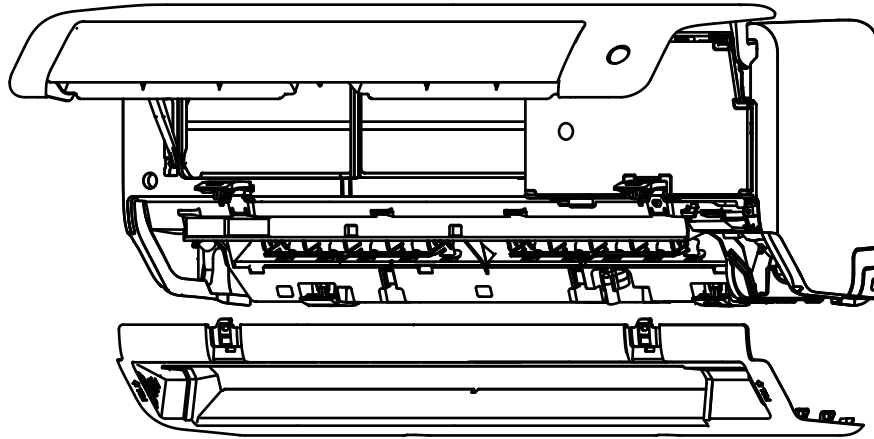

Open the front panel and then remove the lower panel

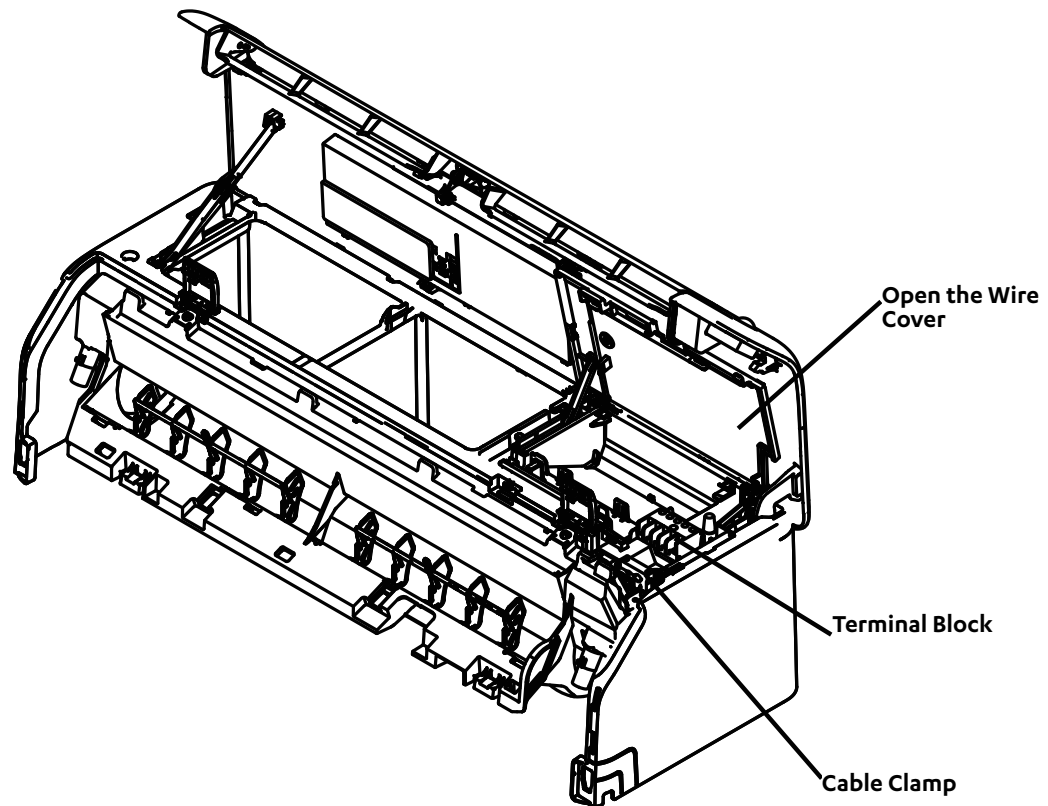

 **CAUTION**

- While connecting the wires, strictly follow the wiring diagram.
- The refrigerant circuit can become very hot. Keep the interconnection cable from the copper tube.

## 12.03. Indoor Unit Wiring Diagram

Fault outputs, remote On/Off and wired control are optional and require use of the multifunction PCB to be utilised - purchase multifunction PCB separately.

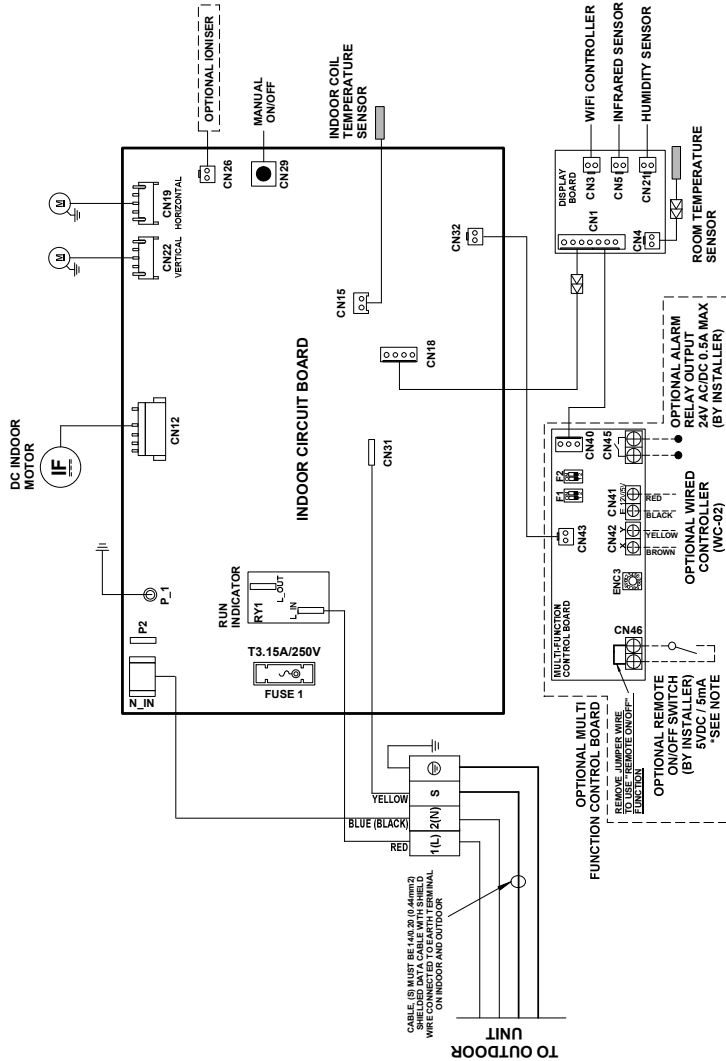

\* NOTE: REMOTE ON/OFF DIP SWITCH SETTINGS

- F2 BOTH 1 & 2 DIP SWITCH OFF  
REMOTE SWITCH INACTIVE
- F2 DIP SW. 1 ON / DIP SW. 2 OFF  
REMOTE SWITCH OPEN = UNIT ON  
REMOTE SWITCH CLOSED = UNIT OFF
- F2 DIP SW. 1 ON / DIP SW. 2 ON  
REMOTE SWITCH OPEN = UNIT OFF  
REMOTE SWITCH CLOSED = UNIT ON

REMOTE SWITCH OPERATION

WHEN THE REMOTE SWITCH IS IN "OFF" MODE THE UNIT WILL BE OFF & THE REMOTE / WIRED CONTROLLER WILL NOT OPERATE IF ON BUTTON PRESSED VIA REMOTE / WIRED CONTROLLER. "CP" WILL BE DISPLAY

WHEN THE REMOTE SWITCH IS IN "ON" MODE THE UNIT WILL OPERATE VIA THE REMOTE / WIRED CONTROLLER AS NORMAL

Base Model No: <b>WIRE-026035/050072/085CS</b>		Variation Code: <b>STANDARD</b>	
Description: <b>INDOOR WIRING DIAGRAM - SERENE 2</b>			
Drawn: <b>RL</b>	Date: <b>28-07-2020</b>	Drawing No: <b>WD3017</b>	Revision Size: <b>B A4</b>
Approved: <b>JL</b>	Date: <b>30-10-2020</b>		
ActronAir		This drawing remains the intellectual property of Actron Engineering Pty Ltd. Reproduction, modification and/or distribution are prohibited without written consent.	
Rev.	Description	By	Date
A		PCR	
B	RENAMED MULTI-FUNCTION BOARD. CONNECTOR CN32 TO CN43. CN28 CHANGE TO PUSH BUTTON	N/A	30-10-2020
		ORIGINAL	

## 12.04. Outdoor Unit Wiring Diagram (WRC-026CS/WRC-035CS)

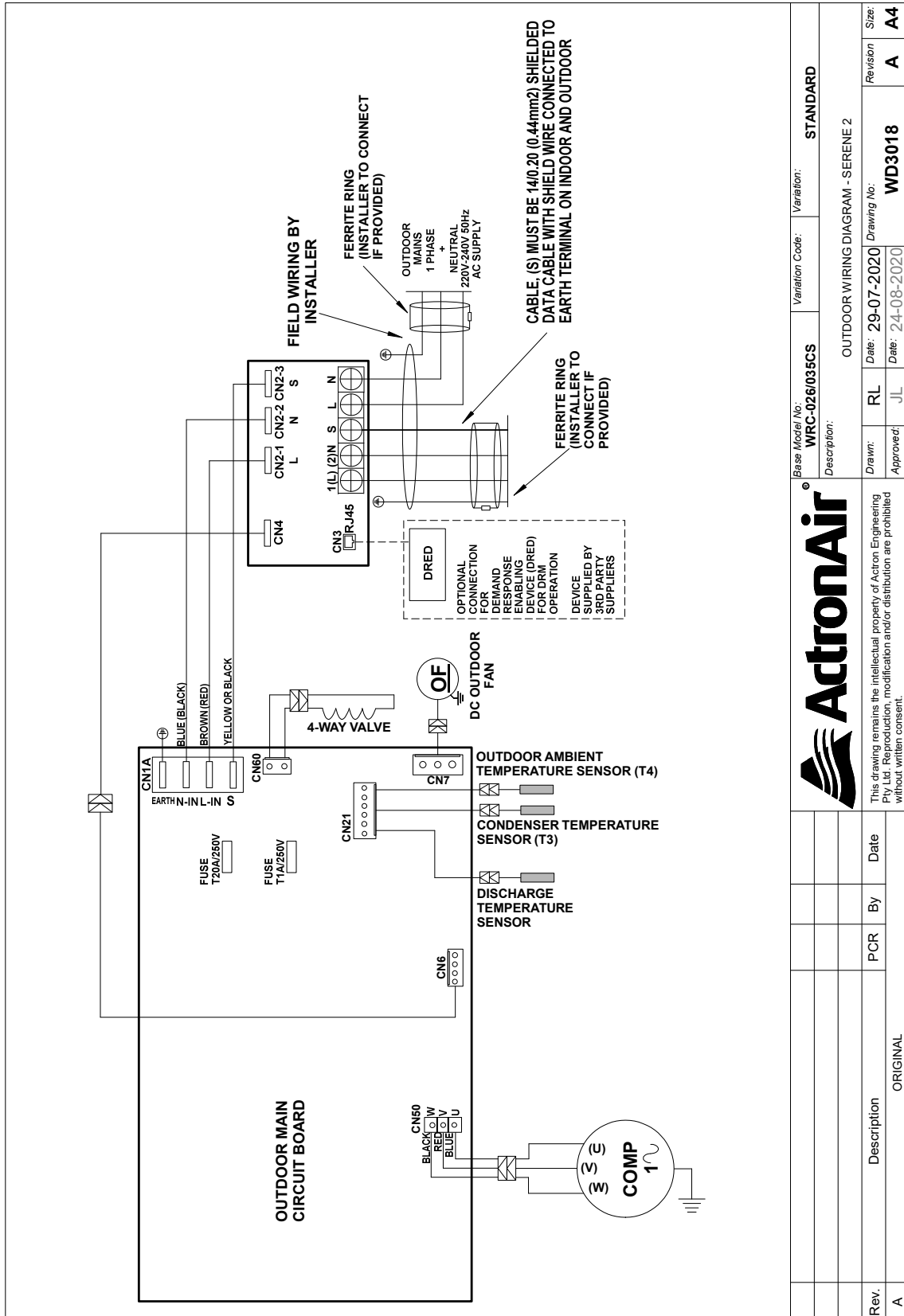

## 12.05. Outdoor Unit Wiring Diagram (WRC-050CS/WRC-072CS/WRC-085CS)

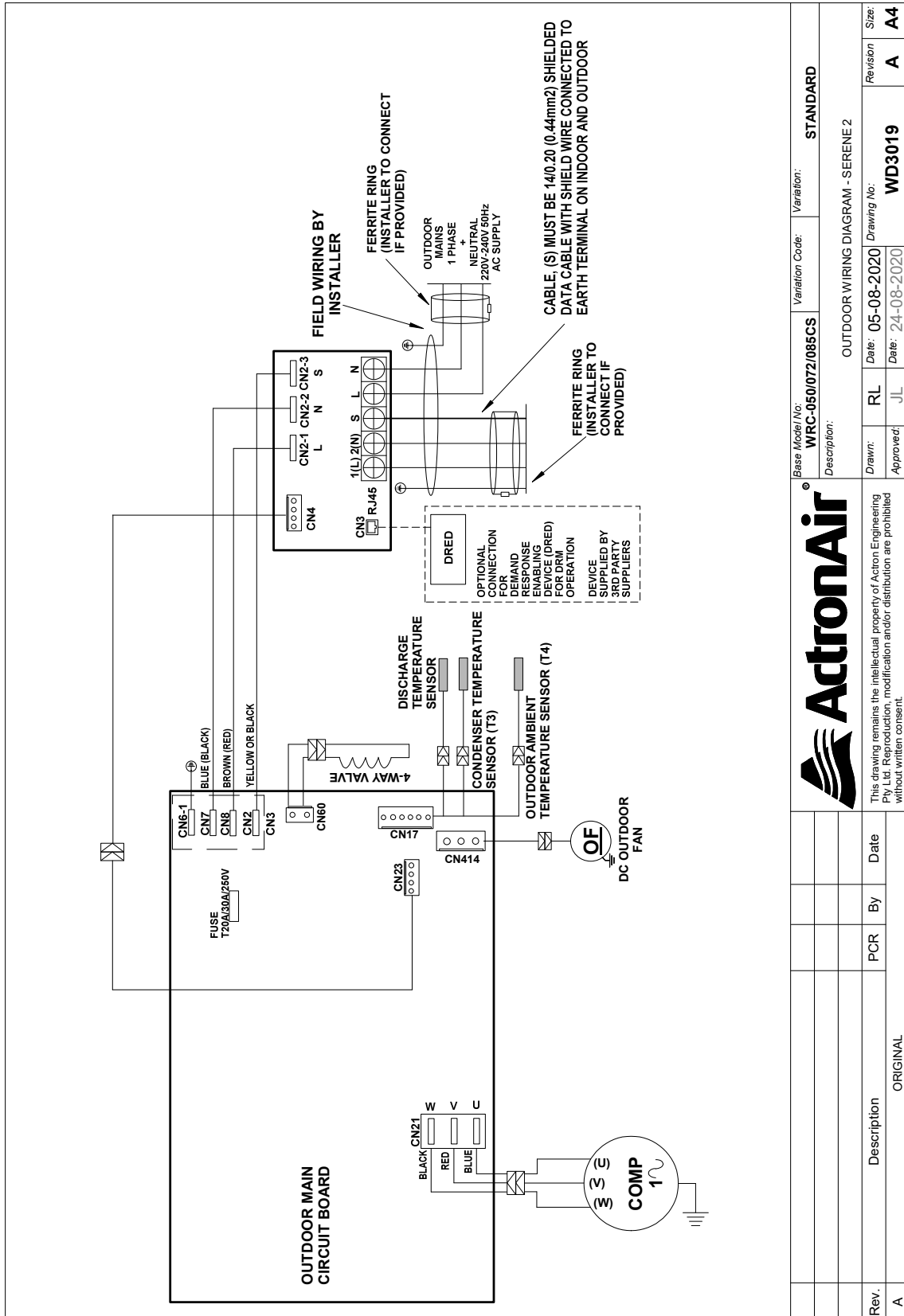

Base Model No: <b>WRC-050/072/085CS</b>		Variation Code: <b>STANDARD</b>
Description: <b>OUTDOOR WIRING DIAGRAM - SERENE 2</b>		
Drawn: <b>RL</b>	Date: <b>05-08-2020</b>	Revision: <b>A</b>
Approved: <b>JL</b>	Date: <b>24-08-2020</b>	Size: <b>A4</b>
Rev. <b>A</b>	Description: <b>ORIGINAL</b>	Drawing No: <b>WD3019</b>

## 12.06. Electrical Connection

### MAINS WIRING (220-240VAC)

- ① (Single Phase + Neutral) 50Hz
  - 1.0 mm<sup>2</sup> - WRC-026CS / WRC-035CS
  - 1.5 mm<sup>2</sup> - WRC-050CS
  - 2.5 mm<sup>2</sup> - WRC-072CS
  - 4.0 mm<sup>2</sup> - WRC-085CS

### ② INTERCONNECT WIRING (220-240VAC)

- (Single Phase + Neutral) 50Hz
  - 1.0mm<sup>2</sup> - WRC-026CS / WRC-035CS
  - 1.5mm<sup>2</sup> - WRC-050CS / WRC-072CS / WRC-085CS

### ③ EXTRA LOW VOLTAGE DATA CONTROL WIRING

- 2 core shielded data cable 14/0.20 (0.44mm<sup>2</sup>)
- maximum 65 metres

### ④ EXTRA LOW VOLTAGE DATA CONTROL WIRING

- 4 core shielded data cable (0.75mm<sup>2</sup>)
- maximum 12 metres

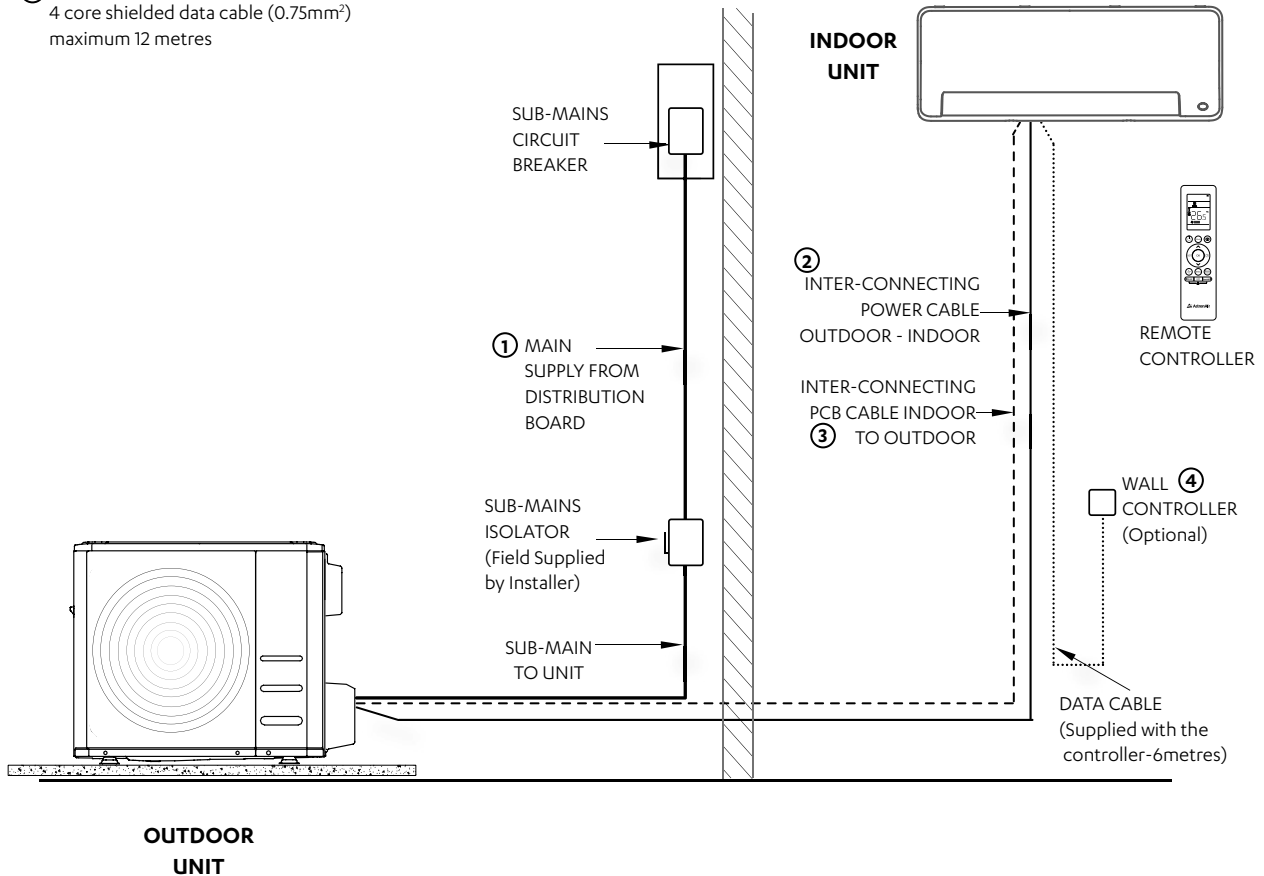

## 13. Leak Test and Air Evacuation

### 13.01. Leak Test

1. Run interconnecting pipe work from condenser to evaporator.
2. Connect the liquid and suction pipe to the indoor and outdoor unit flare connections (please see refrigerant piping connection instruction).
3. Fit service gauge to the service port on the outdoor unit.
4. Fit a nitrogen to the service gauge.
5. Pressurise the system to 4000kPa. A recommended pressure test is to be performed for no less than 1 hour at 4000kPa Bubble test system and ensure pressure does not drop during this time.

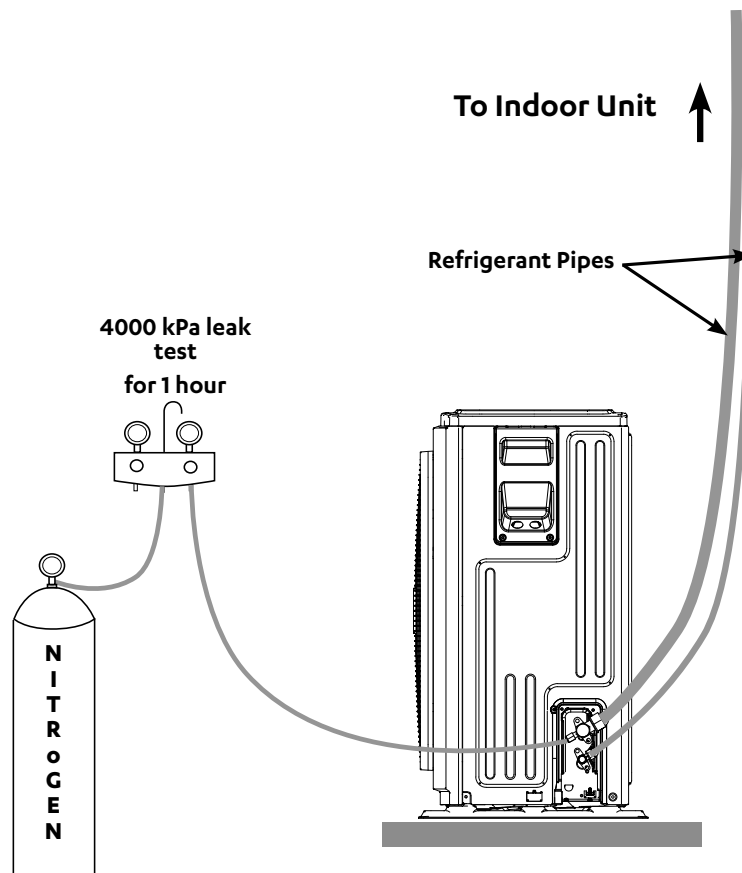

#### **CAUTION**

- Use a vacuum pump and a vac stat reading lower than 500 microns and an air discharge capacity above 40L/min.
- The outdoor unit does not need vacuuming **DO NOT** open the outdoor unit's gas and liquid stop valves.
- Ensure that your vac stat reads 500 micron or below after 2 hours. If after three hours of operation and the vac stat reading is still above 500 microns, check re-pressurise system and check for gas leak. If there is no leakage, perform another evacuation for 1 to 2 hours or until the vac stat reads 500 microns or below.
- **DO NOT** use refrigerant gas during a leak test of a system.
- Ensure all gauge manifold, leak detector and vacuum pump are compatible and safe to use with R-32 refrigerant.

## 13.02. Evacuation Instructions

Before using the manifold gauge and vacuum pump, read their operation manuals to familiarize yourself with how to use them properly.

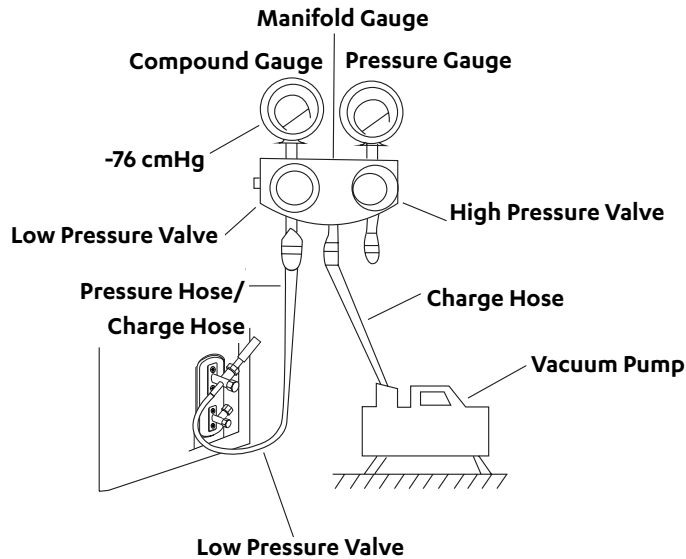

1. Connect the charge hose of the manifold gauge to service port on the outdoor unit's low pressure valve.
2. Connect another charge hose from the manifold gauge to the vacuum pump.
3. Open the Low Pressure side of the manifold gauge. Keep the High Pressure side closed.
4. Turn on the vacuum pump to evacuate the system.
5. Run the vacuum until the compound meter reads 500 microns.
6. Close the Low Pressure side of the manifold gauge, and turn off the vacuum pump.
7. Wait for 5 minutes, then check that there has been no change in system pressure.

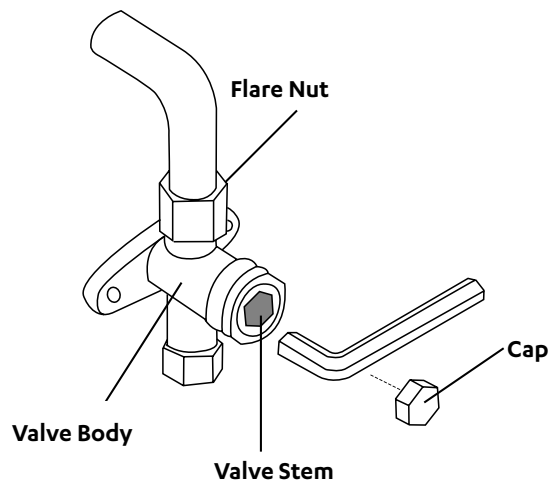



8. Insert hexagonal wrench into the packed valve (high pressure valve) and open the valve by turning the wrench in a 1/4 counterclockwise turn. Listen for gas to exit the system, then close the valve after 5 seconds.
9. Watch the Pressure Gauge for one minute to make sure that there is no change in pressure. The Pressure Gauge should read slightly higher than atmospheric pressure.
10. Remove the charge hose from the service port.
11. Using hexagonal wrench, fully open both the high pressure and low pressure valves.
12. Tighten valve caps on all three valves (service port, high pressure, low pressure) by hand. You may tighten it further using a torque wrench if needed.

 **CAUTION**

When opening valve stems, turn the hexagonal wrench until it hits against the stopper. Do not try to force the valve to open further.

 **CAUTION**

- Refrigerant charging must be performed after wiring, vacuuming and the leak test.
- **DO NOT** exceed the maximum allowable quantity of refrigerant or overcharge the system. Doing so can damage or impact the unit's function.
- Charging with unsuitable substances may cause explosions or accidents. Ensure that the appropriate refrigerant is used.
- Refrigerant containers must be opened slowly. Always use protective gear when charging the system.
- **DO NOT** mix refrigerant types.
- Some systems require additional charging depending on pipe lengths. The standard pipe length is 15m.

### 13.03. Refrigerant Charge Details

Model	WRC-026CS	WRC-035CS	WRC-050CS	WRC-072CS	WRC-085CS
Refrigerant Type	R-32	R-32	R-32	R-32	R-32
Refrigerant Charge (grams)	900	900	1100	1500	1500
Pre-charged Length (metres)	15	15	15	15	15
Additional Refrigerant per metre (grams/metres)	12	12	12	24	24
Liquid Pipe	Ø6.35 (1/4")	Ø6.35 (1/4")	Ø6.35 (1/4")	Ø9.52 (3/8")	Ø9.52 (3/8")
Gas Pipe	Ø9.52 (3/8")	Ø9.52 (3/8")	Ø12.7 (1/2")	Ø15.9 (5/8")	Ø15.9 (5/8")

## 14. Electrical and Gas Leak Checks

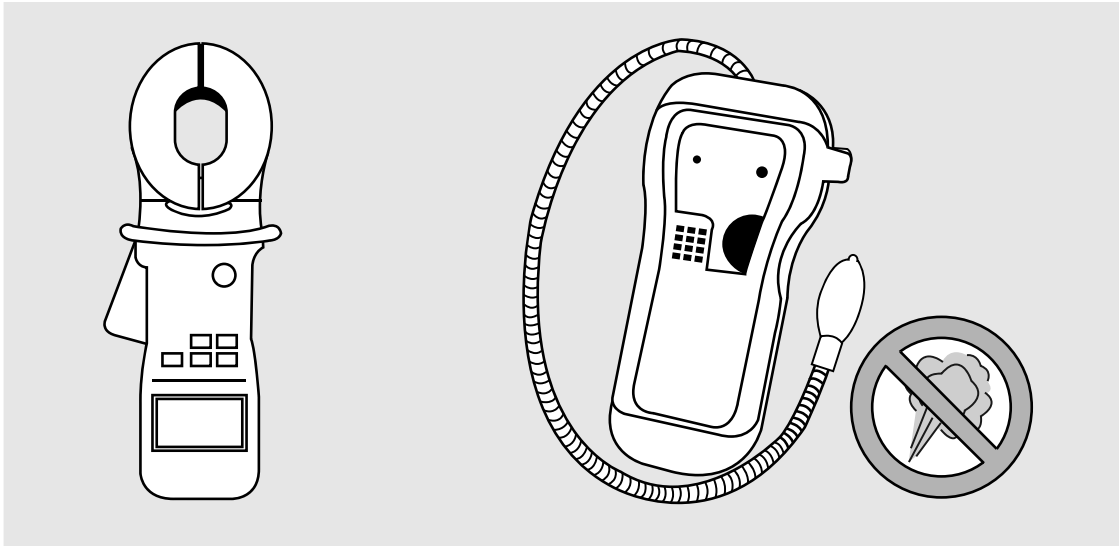

### 14.01. Electrical Safety Checks

After installation, confirm that all electrical wiring is installed in accordance with local and national regulations.

#### **WARNING**

All wiring must comply with local and national electrical codes, and must be installed by a licensed electrician.

### 14.02. Gas Leak Checks

Proper pressure test with dry nitrogen should be performed, prior to air evacuation. Perform leak detection test with electronic leak detector after letting refrigerant into pipework

#### **NOTE**

After confirming that all pipe connection points **DO NOT** leak, replace the valve cover on the outside unit.

## 15. Test Run

### Before Test Run

Only perform test run after you have completed the following steps:

- **Electrical Safety Checks** – Confirm that the unit’s electrical system is safe and operating properly.
- **Gas Leak Checks** – Check all flare nut connections and confirm that the system is not leaking
- Confirm that gas and liquid (high and low pressure) valves are fully open

### Test Run Instructions

You should perform the Test Run for at least 30 minutes.

1. Connect power to the unit.
2. Press the **ON/OFF** button on the remote controller to turn it on.
3. Press the **MODE** button to scroll through the following functions, one at a time:
  - COOL – Select lowest possible temperature
  - HEAT – Select highest possible temperature
4. Let each function run for 5 minutes, and perform the following checks:

List of Checks to Perform	PASS	FAIL
No electrical leakage		
Unit is properly grounded		
All electrical terminals properly covered		
Indoor and outdoor units are correctly installed		
All pipe connection points do not leak		
Water drains properly from drain hose		
All piping is properly insulated		
Unit performs COOL function properly		
Unit performs HEAT function properly		
Indoor unit louvres rotate properly		
Indoor unit responds to remote controller		

5. After the Test Run is successfully complete, and you confirm that all checks points in List of Checks to Perform have PASSED, do the following:
- Using remote control, return unit to normal operating temperature.
  - Using insulation tape, wrap the indoor refrigerant pipe connections that you left uncovered during the indoor unit installation process.

You can't use the remote controller to turn on the COOL function when the ambient temperature is below 17°C. In this instance, you can use the **MANUAL CONTROL** button to test the COOL function.

- Locate the **MANUAL CONTROL** button on the right-hand side panel of the unit.
- Press the **MANUAL CONTROL** button one time to activate FORCED AUTO mode.
- Press the **MANUAL CONTROL** again to activate FORCED COOLING mode.
- Perform Test Run as normal.

### FORCED AUTO MODE

Air conditioning system will go to Auto Mode with 24°C set point.

### FORCED COOL MODE

The outdoor unit will run at minimum capacity and indoor fan in low speed. After 30 minutes, the air conditioning system will go to Auto Mode with 24°C set point.

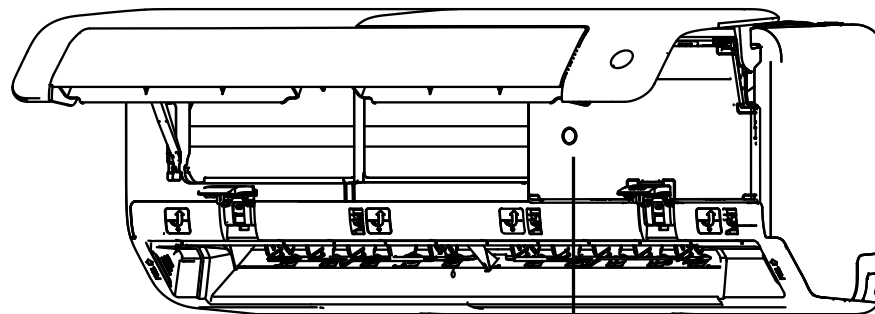

Manual Control Button

6. Fill out the "Total Installed Refrigerant Charge" label located on the plastic valve cover:

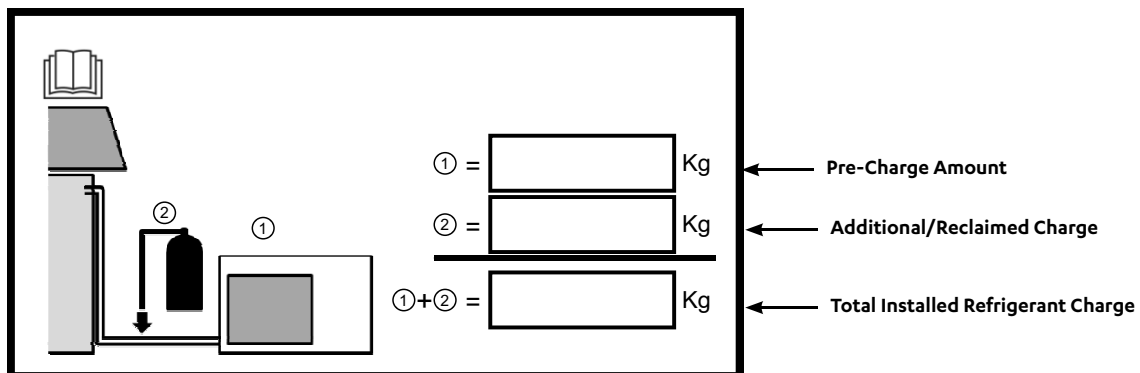

### NOTE

The Pre-Charge Amount is written on the Rating Label of the Outdoor unit. Where adjustment to charge is required to complete the refrigerating system, the installer should note the resulting "Additional/Reclaimed Charge" and "Total Installed Refrigerant Charge" on the label located in the outer part of the valve cover of the Outdoor unit and "Start Up and Commissioning Report" of R-32 Safety Manual.

## 16. Maintenance

### Maintenance Procedures

This section describes the procedures that must be performed as a part of normal maintenance program. Regular servicing of equipment by licensed HVAC technician is highly recommended. Always disconnect electrical power to the unit before performing these procedures. It is always a safe practice to observe all safety warnings and cautions when conducting maintenance tasks.



#### DANGER

##### Live Electrical Connections !

It may be necessary to work with live electrical components on certain maintenance tasks. Only licensed electricians and qualified technicians are allowed to perform these tasks.



#### WARNING

##### Hazardous Voltage !

Always make sure that all power supply, including remote controls, are disconnected before performing maintenance. Observe proper LOCK-OUT / TAG-OUT (LOTO) procedures to ensure that power cannot be inadvertently energised. Failure to disconnect power before maintenance procedures can result in serious injury and/or death.

### Annual Maintenance Checklists

- Perform general maintenance inspections.
- Perform scheduled start-up checks.
- Leak test refrigerant circuits.
- Inspect contacts of all contactors and relays. Replace all worn contacts as required.
- Inspect, clean and tighten all electrical connections.
- Check fans for balanced operation. Make sure that there are no loose screws/bolts, no fan blades interference and no damage to the fans and guards.
- Inspect the air filters, clean or replace as required.
- Clean and repaint any corroded panel section.
- Ensure no blockage of airflow through variable speed drive and drive fan is operating correctly.

### Cleaning the Condenser Coils

Clean the coils at least once a year or more frequently if unit is located in a dusty and dirty environment, in order to maintain your system's proper operating performance. High discharge pressures are good indication that the coils need cleaning. When using detergent or solvents to clean the coils, follow the manufacturer's instructions to avoid potential damage to the coils and to the unit.

To clean the refrigerant coils, use a soft brush and water spray, such as garden hose or pressure washer with low pressure nozzle.



#### DANGER

##### Beware of Rotating Fan Blades !

- Always make sure that all power supply, to the Outdoor Fans are turned-off and isolated.
- Observe WH&S safety procedures, do not wear loose clothing and any jewellery when working near the fans.
- Wear PPE whenever performing any maintenance procedures.
- Observe all necessary procedures when working on a confined space.



**Do Not Use High Alkaline Detergent !**

When using detergent for coil cleaning, ensure that the alkaline level is no higher than 8.5, which can cause corrosion damage to the coils.

**Coil Cleaning Procedures**

- Disconnect power to the unit.
- Remove the louvered panels from the unit to gain access to the air inlet side of the coils.
- Use a soft brush to remove loose dirt and debris from both sides of the coils.
- Straighten bent coil fins with fin comb.
- Prepare the detergent solutions according to the manufacturer’s instructions.
- Spray solution at a 90° angle to the coils, keeping a minimum nozzle spray angle of 15°, with at least a 1800mm distance from the coils and 600 psi pressure.
- Spray leaving air side of the coils first then the air inlet side. Allow the solution to stand on the coils for five minutes.
- Rinse both sides of the coils with cool clean water.
- Inspect the coils, if they are still dirty, repeat the cleaning procedure.
- Clean and wipe dry the outer and inner sides of the unit, the refrigerating parts and other components.
- Ensure that the condensate drain lines are not blocked.
- Reinstall all unit panels, covers and guards.
- Restore electrical power to the unit.

## 17. Maintenance Frequency Checklist

Regular servicing of equipment by a qualified technician is recommended every 12 months for residential applications and every quarter for commercial applications. Regular servicing of your unit helps in maintaining its optimum performance and reliability. **The following checklist and service periods are provided as a guide only, as some sites may require more frequent servicing.**

Electrical									
Parts	Service Frequency					Detail of Service Check	Service Methods		
	1 Mth	3 Mth	6 Mth	1 Yr	2 Yrs			3 Yrs	4 Yrs
Printed Circuit Boards				✓		Visual Inspection.	Tighten Terminals as necessary on printed circuit boards.		
Electrical Connections				✓		Check all electrical terminals, mains, communications, etc.	Re-tighten if loose.		
Magnetic Contactor				✓		Check for loose terminal connections.	Tighten electrical terminals. Remove any dust.		

Outdoor Unit										
Parts	Service Frequency								Detail of Service Check	Service Methods
	1 Mth	3 Mth	6 Mth	1 Yr	2 Yrs	3 Yrs	4 Yrs	5 Yrs		
Casing/Panels and Frames				✓					Visual check for damage, rust and dust accumulation.	For highly corrosive environment, wash panels quarterly with water & neutral detergent solution. Wax panels. Repair / re-paint where required.
Insulation				✓					Visual check for insulation conditions.	Repair / replace insulation material.
Fan				✓					Visual check for run out of balance and dust accumulation.	Clean off dust as necessary to negate possibility of fan running out of balance.
Motor				✓ Ω					Visual check on wiring. Insulation resistance check to be carried out annually.	Measure insulation resistance. Should be more than 1MΩ.
Heat Exchanger				✓					Check for clogging by dust. Check for leaks / damage.	Clean air inlet side as necessary. Straighten any bent fins using fins comb.
Condensate Drain Line (if available)				✓					Check for obstructions & free flow of water.	Clean to eliminate obstructions/sludge & check condition of drain line. Pour water to ensure free flow.
Compressor				✓ Ω					Check for high / low pressure. Measure insulation resistance. Check compressor for abnormal noise/vibrations.	Measure insulation resistance. Should be more than 1MΩ. Ensure to isolate first the VSD from the compressor before measuring insulation resistance.
Compressor drive				✓					For variable drive compressor check full operation of drive from minimum hertz to maximum, check fan operation of drive.	Check compressor amperage & running frequency feedback from outdoor board seven segment display.
				✓					Ensure drive fresh air path is clear and drive fan is operating correctly.	Check ventilation holes on top and bottom of drive cover are clear of leaves, pebbles or dirt.
Refrigeration Operational Readings				✓					Make note of operational reading in test cool/heat mode.	Check operating pressures, record super heat & sub-cool values.
Safety Devices				✓					Check calibration of safety devices.	Check resistance of sensors, pressure cut in / cut out of pressure controls.
Faults				✓					Check for any previous fault history on unit.	Investigate any causes for previous faults, reset fault history.

Indoor Unit										
Parts	Service Frequency								Detail of Service Check	Service Methods
	1 Mth	3 Mth	6 Mth	1 Yr	2 Yrs	3 Yrs	4 Yrs	5 Yrs		
Casing/Panels and Frames				✓					Visual check for damage, rust and dust accumulation.	For highly corrosive environment, wash panels quarterly with water & neutral detergent solution. Wax panels. Repair / re-paint where required.
Insulation				✓					Visual check for insulation conditions.	Repair / replace insulation material.
Fan				✓					Visual check for run out of balance and dust attached.	Clean off dust as necessary to negate possibility of fan running out of balance.
Motor				✓ Ω					Visual check on wiring. Insulation resistance check to be carried out annually.	Measure insulation resistance to earth with Megger. Insulation resistance should be more than 1MΩ.
Heat Exchanger				✓					Check for clogging by dust. Check for leaks / damage.	Clean air inlet side as necessary. Straighten any bent fins using fins comb.
Drain Pan/ Condensation line				✓					Check for obstructions & free flow of water.	Clean to eliminate obstructions/ sludge & check condition of pan. Pour water to ensure free flow.
Filter*	✓								Check for clogging by dust.	Clean / Replace Filter.
Temperature Readings				✓					Measure air on & air off.	Place temperature probe in return & supply air of unit.

\*Service period for filter cleaning may vary depending on operating time & surrounding environment



**THIS PAGE WAS INTENTIONALLY LEFT BLANK**

**THIS PAGE WAS INTENTIONALLY LEFT BLANK**

**THIS PAGE WAS INTENTIONALLY LEFT BLANK**

