

HERCULES PACKAGE UNIT

35kW - 139kW
OPERATING RANGE

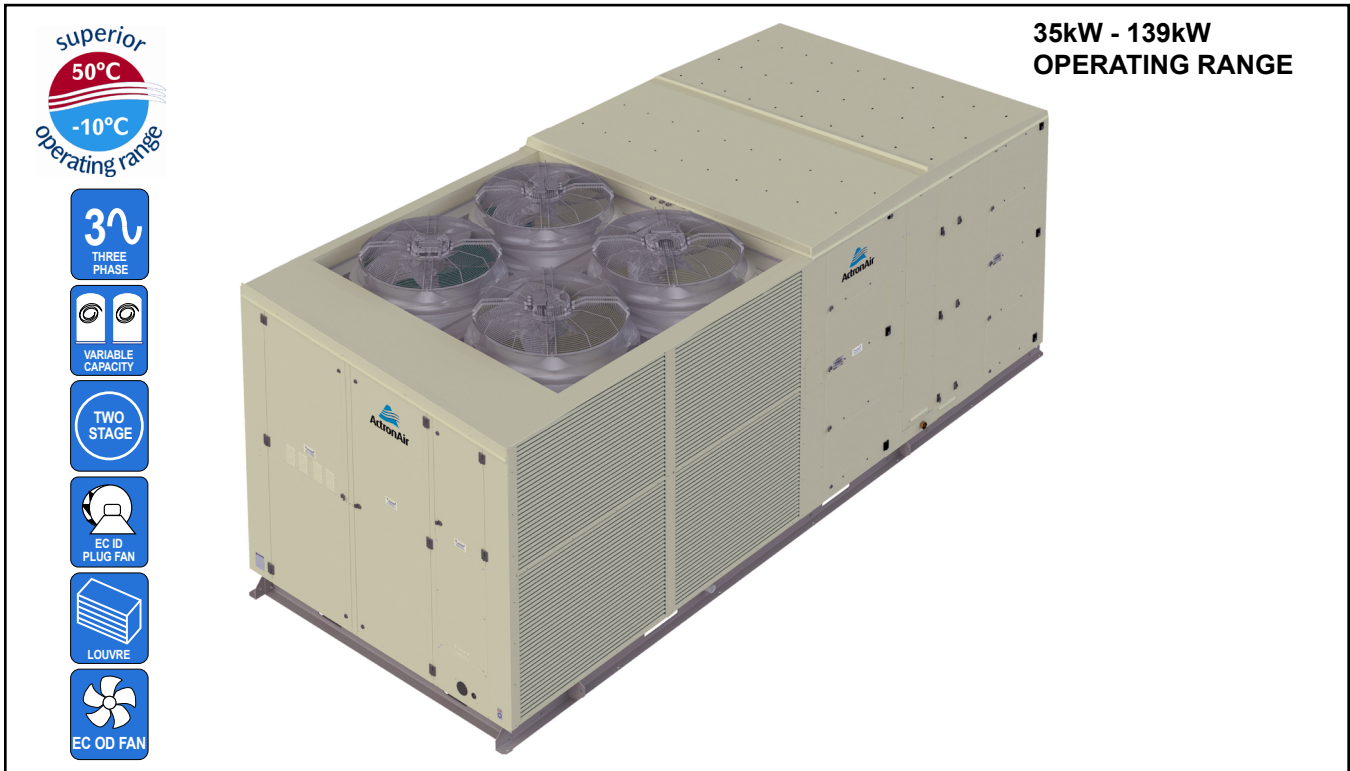

3 Phase
139.00 kW
Hercules

UNIT FEATURES

- Variable Speed Scroll Compressors
- Automatic Compressor Run Time Management
- Bi-Flow Electronic Expansion Valves
- Full Factory Charged with R-410A Refrigerant
- EC Variable Speed Outdoor Fans - up to 80Pa External Static Pressure as Standard
- Blue Hydrophilic Coat Coil Fin Protection - Outdoor Coil & Indoor Coil
- Louvred Outdoor Coil Guard
- External Stainless Steel Screws
- EC Variable Speed Backward Curve Indoor Plug Fan
- Adjustable Indoor Fan Airflow Setpoint
- Automatic Air Volume Control within Fan Limits
- Control Interface with LCD Display - Included for System Operation
- Adjustable Dirty Return Air Filter Alarm
- Active Power Factor Correction
- 100mm Return Air Filter Rails with Optional Sliders - Fitted
- Foil Faced Polyethylene Insulation - Indoor Section
- Three Phase Protection on all Motors

CONTROL FEATURES

- ActronAir CP10 Control Interface (BCA Compliant)**
- Auto / Cool / Heat / Fan Only Modes
 - 7-Day Time Clock with 2 On / Off Events per Day
 - 12 Programmable Special Days with 2 On / Off Events per Day
 - Daylight Saving Time Function
 - Indoor Coil Freeze Protection / Auto Defrost Operation
 - HP / LP Safety Protection
 - PI Compressor Algorithm (Proportional Band + Time Integral)
 - Compressor Operating Envelope Control
 - Compressor Discharge Temp. Control and Run Time Management
 - Alarm Fault Data Logger
 - LCD Screen Displays Operating Status, Mode and Menu Information

UNIT & CONTROL OPTIONS

- ActronAir CP05 Control Interface (BCA Compliant)
- BMS Compatibility
- 3rd Party Control
- ⁽¹⁰⁾ Economy Cycle Dampers and Motors (Bottom Return Air Only)
- Various Supply Air / Return Air Configuration options
- Reheat / Dehumidification

UNIT COMPLIANCE

- MEPS (GEMS Determination 2020)
- Demand Response AS4755.3.1
- AS/NZS CISPR 11:2011 (Group 1 Class A)
- AS/NZS 3100:2002 Approval and Test Spec - General Req. Electrical Equipment

SPECIFICATION SUMMARY

PACKAGE UNIT MODEL	PKV1400T	
	⁽¹⁾ TOTAL	⁽²⁾ NETT
⁽³⁾ COOLING CAPACITY (kW)	139.00	135.00
⁽³⁾ SENSIBLE CAPACITY (kW)	118.75	114.75
⁽⁴⁾ HEATING CAPACITY (kW)	130.00	134.00
⁽⁵⁾ COOLING INPUT POWER (kW)	44.84	
⁽⁵⁾ HEATING INPUT POWER (kW)	40.04	
EER	3.10	3.01
COP	3.25	3.35
⁽⁶⁾ INDOOR AIRFLOW (l/s) - MIN. / NOMINAL / MAX.	5920 / 7400 / 8880	
⁽⁷⁾ OUTDOOR SOUND PRESS. LEVEL @ 3M dB(A) - HIGH / MAX.	59.1 / 66.2	
OUTDOOR SOUND POWER LEVEL dB(A) - HIGH / MAX.	76.1 / 83.2	
POWER SUPPLY	400V / 3Ph+N / 50Hz	
⁽²⁾ RATED LOAD AMPS	71.6	
⁽⁸⁾ FULL LOAD AMPS	95.62	
⁽⁹⁾ MAINS CIRCUIT BREAKER SIZE	100.0 A	
MAXIMUM INRUSH CURRENT	18.0 A	
POWER FACTOR (Minimum)	0.92	
WEIGHT - UNIT / PACKAGE (kg)	2716 / 2790	

⁽¹⁾ Based on unit rating excluding indoor fan kW.
⁽²⁾ Measured and tested in accordance with AS/NZS 3823.1.2.
⁽³⁾ At 27°C DB / 19°C WB entering air temperatures and 35°C ambient.
⁽⁴⁾ At 20°C DB entering air temperature and 7°C DB / 6°C WB ambient.
⁽⁵⁾ Total input power excludes indoor fan kW.
 Nett input power includes indoor fan kW.
⁽⁶⁾ Max. - Min. airflow application range.
⁽⁷⁾ Outdoor sound pressure level is determined in an anechoic chamber and may differ once the unit is installed due to environment conditions.
⁽⁸⁾ Full Load Amps are based on compressor and fan motors' maximum expected current.
⁽⁹⁾ See Specifications sheet for Mains Circuit Breaker size details.
⁽¹⁰⁾ Return Air Sensor needs to be relocated by the installer specific to site requirements.
 Note: Use input power to estimate running cost.

CAPACITY SELECTION DATA

PKV1400T

COOLING PERFORMANCE

AIR ENTERING			TOTAL SENSIBLE CAPACITY - kW											
OUTDOOR DB - °C	INDOOR WB - °C	TOTAL CAPACITY kW	AT DB TEMPERATURE ONTO INDOOR COIL - °C											
			20	21	22	23	24	25	26	27	28	29	30	
25	16	143.91	97.11	105.00	111.85	119.61	126.98	134.26						
	17	147.14	88.85	97.07	104.86	112.92	119.45	126.96	134.34					
	18	150.94	80.32	88.60	96.84	104.71	112.64	119.27	126.92	134.31	141.66			
	19	155.22	71.65	80.15	88.34	96.62	104.57	112.40	119.09	126.65	134.15	141.42	148.77	
	20	159.67	62.94	71.41	79.72	88.00	96.23	104.31	112.16	118.80	126.54	134.04	141.31	
	21	163.73		62.50	70.89	79.49	87.69	95.89	103.96	111.88	119.60	126.29	133.82	
22	168.53			61.98	70.45	78.88	87.26	95.54	103.52	111.58	119.26	125.86		
30	16	136.63	93.50	101.36	108.21	115.78	123.29	130.36						
	17	140.11	85.35	93.41	101.28	108.07	115.78	123.30	130.46					
	18	143.55	76.83	85.11	93.26	101.21	108.95	115.62	123.05	130.40	137.61			
	19	147.50	68.31	76.67	84.90	92.99	100.93	108.64	115.35	122.96	130.30	137.60		
	20	151.46	59.42	67.92	76.33	84.61	92.76	100.69	108.52	115.07	122.76	130.26	137.49	
	21	155.49		59.12	67.55	75.93	84.13	92.29	100.34	108.23	114.79	122.38	129.87	
22	159.69			58.58	67.12	75.43	83.67	92.00	99.97	107.79	115.45	122.01		
35	16	130.03	89.49	97.34	104.14	111.64	118.99	125.94						
	17	132.26	81.45	89.42	97.23	103.96	111.56	119.05	126.15					
	18	135.39	72.97	81.25	89.24	97.05	103.74	111.47	118.88	126.19				
	19	139.00	64.41	72.81	80.97	89.06	96.82	104.66	111.27	118.75	126.08	133.25		
	20	142.52	56.06	64.36	72.36	80.15	88.38	96.08	104.17	110.96	118.79	126.36	134.20	
	21	146.34		55.47	63.68	71.52	79.86	87.93	96.08	104.03	110.80	118.69	126.81	
22	150.24			54.80	62.84	71.27	79.42	87.84	96.00	103.99	110.68	118.99		
40	16	122.62	85.65	93.14	99.50	106.34	113.61							
	17	123.44	77.64	85.27	92.78	98.75	106.37	113.63						
	18	126.36	69.19	77.18	84.87	92.04	98.72	106.16	113.95	121.39				
	19	129.50	60.68	68.75	76.70	84.06	91.89	98.47	106.31	114.11	121.52			
	20	132.69	51.91	60.17	68.32	75.99	83.97	91.68	98.61	106.34	114.13	121.67	129.49	
	21	136.13		51.35	59.53	67.48	75.74	83.59	91.61	99.63	106.33	114.10	122.12	
22	139.62			50.81	58.71	67.10	75.20	83.64	91.60	99.43	106.30	114.27		
45	16	114.17	80.61	87.28	94.45	101.10								
	17	114.22	72.85	80.33	86.90	93.75	101.21	108.26						
	18	116.29	64.52	72.49	79.97	87.10	93.77	101.02	108.61					
	19	118.95	56.05	64.13	72.04	79.25	86.93	93.55	101.23	108.84	116.15			
	20	121.71	47.38	55.55	63.09	71.20	79.11	86.65	93.62	101.20	108.79	116.16		
	21	125.12		46.85	55.07	62.91	71.08	78.88	86.72	93.57	101.25	108.78	116.63	
22	127.86			46.33	54.33	62.59	70.63	78.74	86.61	93.50	101.16	109.07		
50	16	103.78	74.99	81.20	88.85	95.26								
	17	105.00	67.26	75.02	80.75	88.17	95.44							
	18	106.22	59.17	67.47	74.69	81.69	88.30	95.24						
	19	108.39	50.82	59.32	67.03	74.07	81.50	88.05	95.49	102.84				
	20	110.73	42.20	50.88	57.68	66.11	73.86	81.16	88.06	95.39	102.68			
	21	114.10		42.42	50.54	58.18	66.10	73.77	81.34	87.16	95.54	103.37	110.98	
22	116.09			41.92	49.88	58.92	65.72	73.44	81.12	87.16	95.82	103.76		

HEATING PERFORMANCE

WB TEMP ON OD COIL - °C	HEATING CAPACITY - kW									
	AT DB ENTERING INDOOR - °C									
	16		18		20		22		24	
	TH	IH	TH	IH	TH	IH	TH	IH	TH	IH
-10	82.29	77.35	81.83	76.92	81.42	76.54	80.97	76.11	80.51	75.68
-8	88.39	82.20	87.90	81.75	87.45	81.33	86.96	80.87	86.46	80.41
-6	94.49	86.93	93.97	86.45	93.48	86.01	92.95	85.52	92.41	85.01
-4	100.59	90.03	100.03	89.53	99.51	89.07	98.95	88.56	98.35	88.03
-2	106.70	92.83	106.10	92.31	105.54	91.82	104.94	91.30	104.30	90.74
0	112.80	97.01	112.17	96.47	111.57	95.95	110.93	95.40	110.25	94.82
2	118.66	105.61	118.04	105.05	117.31	104.40	116.61	103.79	115.87	103.13
4	124.99	118.74	124.32	118.10	123.57	117.39	122.75	116.61	121.92	115.82
6	131.60	131.60	130.84	130.84	130.00	130.00	129.16	129.16	128.20	128.20
8	138.48	138.48	137.60	137.60	136.68	136.68	135.72	135.72	134.71	134.71
10	145.42	145.42	144.43	144.43	143.39	143.39	142.29	142.29	141.15	141.15
12	152.79	152.79	151.68	151.68	150.51	150.51	148.92	148.92	148.01	148.01
14	160.03	160.03	158.77	158.77	157.38	157.38	156.13	156.13	155.08	155.08
16	167.87	167.87	166.50	166.50	165.07	165.07	163.96	163.96	162.37	162.37
18	176.01	176.01	174.48	174.48	173.31	173.31	171.63	171.63	169.51	169.51

TH - Total Heating Capacity (kW).
IH - Integrated Heating Capacity (kW)
Includes defrost losses.

AIRFLOW CORRECTION MULTIPLIER

% VARIATION	-20%	-15%	-10%	-5%	NOMINAL	5%	10%	15%	20%
INDOOR AIRFLOW (l/s)	5920	6290	6660	7030	7400	7770	8140	8510	8880
TOTAL COOLING	0.977	0.984	0.990	0.996	1.000	1.003	1.009	1.012	1.016
SENSIBLE COOLING	0.905	0.929	0.953	0.978	1.000	1.020	1.044	1.064	1.084
HEATING FACTOR	0.979	1.013	0.990	0.995	1.000	1.004	1.009	1.013	1.018

NOTES:

- No allowance has been made for the effect of indoor fan motor.
- Selection tables are based on nominal airflows. Correction factors must be applied for selection away from these conditions.



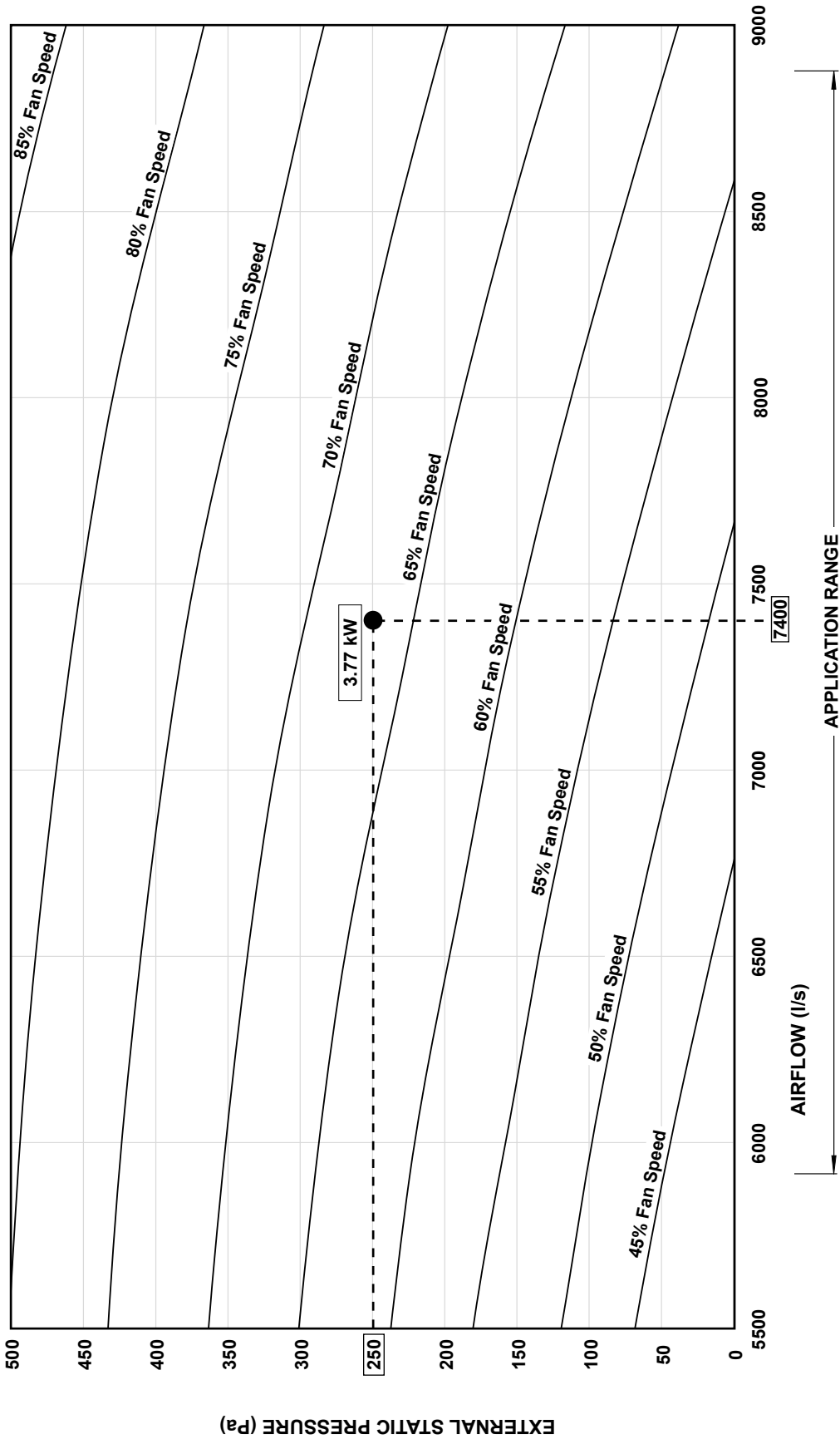

NOTES:

This Fan Curve shows the relationship between Airflow Volume (l/s), Fan Speed % and External Static Pressure.
 Example: Airflow of 7,400 l/s with Ext. Static Press of 250 Pa will require 66.9% Fan Speed.
 For Internal Sensors Control, set Airflow Volume (l/s) on the Control Interface via Service Menu, as follows:
 G. Service Menu → f. Service settings → c. Thermoregulation → Gfc4 Supply Air Volume Setpoint
 For External Inputs or BMS Demand, set the corresponding (0-10V or 0-100%) inputs for the required % Fan Speed.

3 Phase
 Hercules
 139.00 KW



INDOOR FAN DATA

PKV1400T

139.00 kW
3 Phase Hercules

EXTERNAL STATIC PRESSURE (Pa)

AIRFLOW (l/s)	50		100		150		200		250		300		350		400		450		500	
	% Speed	kW	% Speed	kW	% Speed	kW	% Speed	kW	% Speed	kW	% Speed	kW	% Speed	kW	% Speed	kW	% Speed	kW	% Speed	kW
5920	45.2	1.18	49.9	1.54	54.1	2.02	58.1	2.47	62.1	2.99	66	3.55	69.8	4.10	73.3	4.72	76.9	5.35	80.4	5.96
6000	45.6	1.20	50.2	1.56	54.4	2.05	58.4	2.50	62.3	3.02	66.2	3.59	70	4.13	73.4	4.77	77	5.40	80.5	6.01
6500	48.1	1.37	52.3	1.79	56.3	2.25	60.3	2.73	63.7	3.27	67.4	3.82	71.1	4.41	74.5	5.07	77.8	5.69	81.1	6.35
7000	50.6	1.57	54.5	2.03	58.3	2.47	62	2.99	65.5	3.55	68.9	4.09	72.2	4.69	75.6	5.36	78.9	5.99	82	6.69
7400	52.5	1.77	56.3	2.23	60	2.66	63.5	3.22	66.9	3.77	70.3	4.35	73.4	4.97	76.6	5.60	79.9	6.25	82.9	6.98
7500	53	1.81	56.7	2.28	60.4	2.71	63.9	3.28	67.3	3.83	70.7	4.41	73.7	5.04	76.8	5.66	80.1	6.31	83.1	7.05
8000	55.6	2.05	59.2	2.54	62.5	3.04	65.8	3.56	69.3	4.14	72.4	4.76	75.4	5.40	78.3	6.00	81.3	6.69	84.2	7.42
8500	58.2	2.31	61.6	2.84	64.8	3.39	68	3.90	71.1	4.45	74.2	5.13	77.2	5.77	80.1	6.39	82.8	7.11	85.5	7.83
8880	60.2	2.51	63.4	3.11	66.5	3.65	69.7	4.18	72.6	4.76	75.6	5.41	78.6	6.05	81.4	6.74	84.1	7.47	86.7	8.17

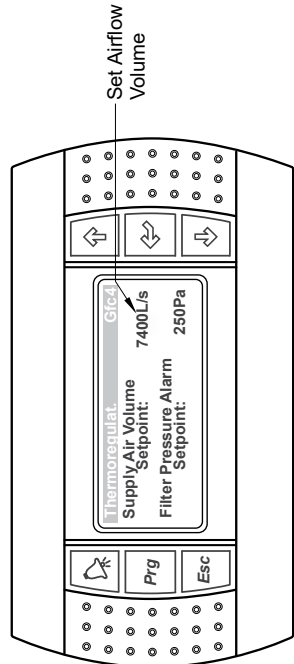

NOTES:
 Airflow = Supply Airflow, L/s
 (Value is set on the Control Interface via G. Service Menu*)
 % Speed = Corresponding Indoor Fan Speed at Set Static.
 kW = Indoor Fan Power, kilowatts
 - Data in the box indicates values at selected Airflow.
 Performance Fan Data shown is at Dry Coil Condition and without air filters.
 For system with Re-Heat Coil, please see page 10 for Re-Heat Coil pressure drop.

* NOTE: Set the Airflow on the Control Interface as follows:
 G. Service Menu → f. Service settings → c. Thermoregulation → Gfcl Supply Air Volume Setpoint



PACKAGE UNIT DIMENSIONS

PKV1400T

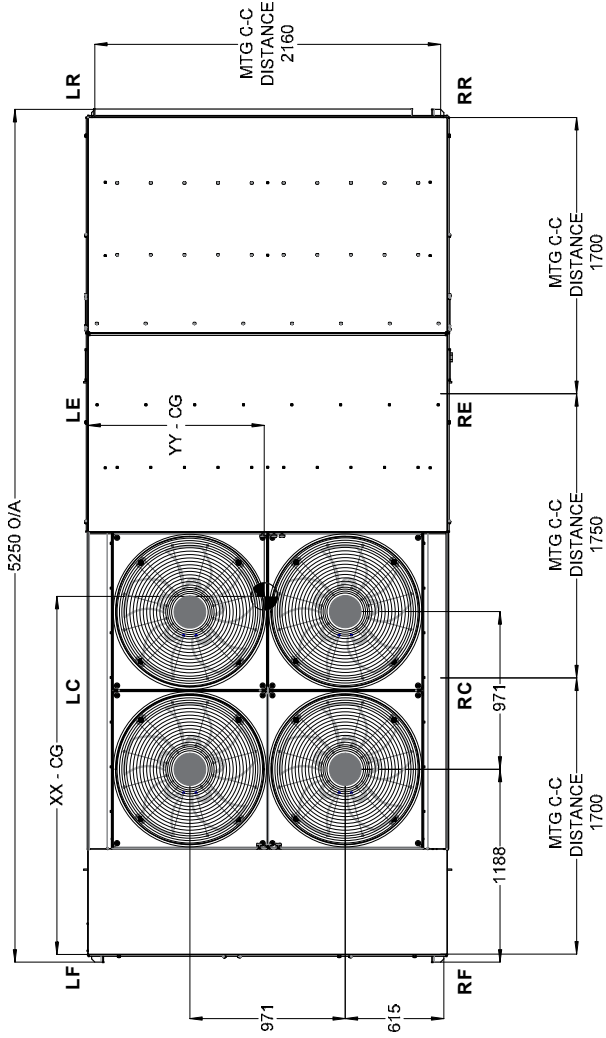

TOP VIEW

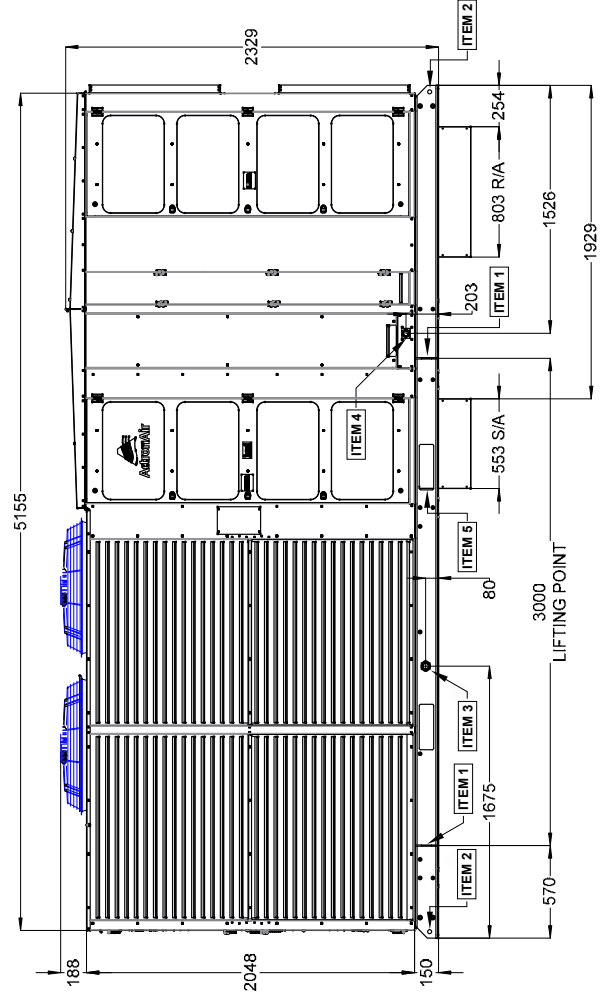

SIDE VIEW

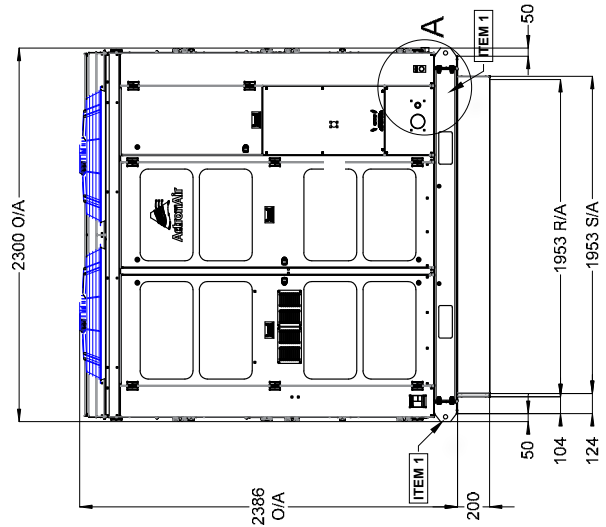

FRONT VIEW

THIRD ANGLE PROJECTION
 DIMENSION (H x W x D) = 2386 x 5250 x 2300
 SUPPLY DUCT (W x L) = 553 x 1953
 RETURN DUCT (W x L) = 803 x 1953
 USE M14 BOLT FOR FEET MOUNTING
 DO NOT SCALE DRAWING.
 ALL DIMENSIONS ARE IN MM UNLESS SPECIFIED.

DENOTES CENTRE OF GRAVITY (CG)

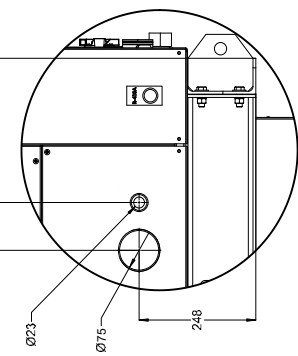

DETAIL A
ELECTRICAL ACCESS

ITEM	DESCRIPTIONS
ITEM 1	LIFTING HOLES 4 x 26 mm (MAIN LIFTING POINTS)
ITEM 2	LIFTING HOLES 4 x 26 mm (SECONDARY OPTIONAL)
ITEM 3	OUTDOOR SECTION CONDENSATE DRAIN COUPLING 2 X 31.8 (1-1/4") BSP FEMALE SOCKET
ITEM 4	INDOOR SECTION CONDENSATE DRAIN BRASS CONNECTOR 31.8 (1-1/4") BSP FEMALE THREAD
ITEM 5	FORKLIFT TINE HOLES 280 x 90 mm (2 EACH LH & RH SIDE)

3 Phase Hercules

139.00 KW

SERVICE ACCESS AREAS AND AIRFLOW CLEARANCES

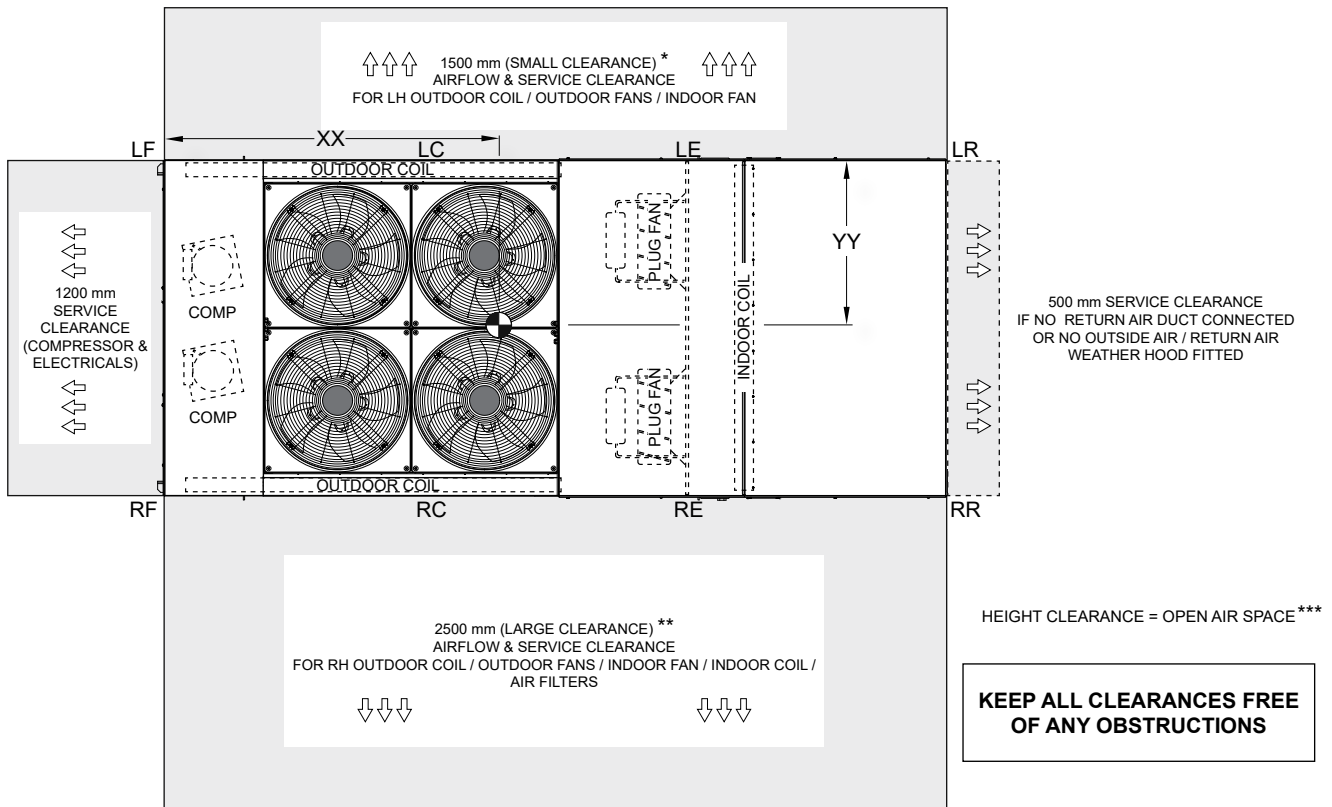

- * AIRFLOW CLEARANCE OF 1500mm IS FOR OPEN AIR SPACE INSTALLATION, A MINIMUM OF 2500mm AIRFLOW CLEARANCE MUST BE PROVIDED FOR CLOSE SPACE AREAS WITH WALLS HIGHER THAN THE UNIT. PLEASE NOTE THAT UNDER ALL CIRCUMSTANCES, CONDENSER AIR MUST NOT RECIRCULATE BACK ONTO CONDENSER COIL.
- ** PREFERRED SERVICE ACCESS FOR INDOOR COIL. SHOULD SERVICE ACCESS BE REQUIRED ON THE OPPOSITE SIDE, THE TWO SIDE CLEARANCES WILL SWAP WITH THE SAME CONDITION APPLIED FOR SMALL CLEARANCE SIDE.
- *** MINIMUM HEIGHT CLEARANCES FOR INSTALLATION WITH LIMITED HEIGHT CLEARANCE ARE AS FOLLOWS:
 1500mm, IF 2500mm SERVICE CLEARANCE FOR INDOOR COIL IS AVAILABLE ON BOTH SIDES OF THE UNIT.
 2500mm, IF 2500mm SERVICE CLEARANCE FOR INDOOR COIL IS NOT AVAILABLE ON EITHER SIDE OF THE UNIT.

UNIT AIR HANDLING CONFIGURATION	NO. OF POINTS	UNIT WEIGHT (kg)	PACKAGE WEIGHT (kg)	SUGGESTED ANCHOR POINTS WEIGHT DISTRIBUTION (kg)								CENTRE OF GRAVITY (mm)	
				LF	LC	LE	LR	RF	RC	RE	RR	XX	YY
DOWN DISCHARGE	8	2716	2790	415	387	302	260	413	383	298	258	2236	1102

UNIT BASE DIMENSIONS

• Applicable to units with Down Supply and Bottom Return Air Handling configuration only.

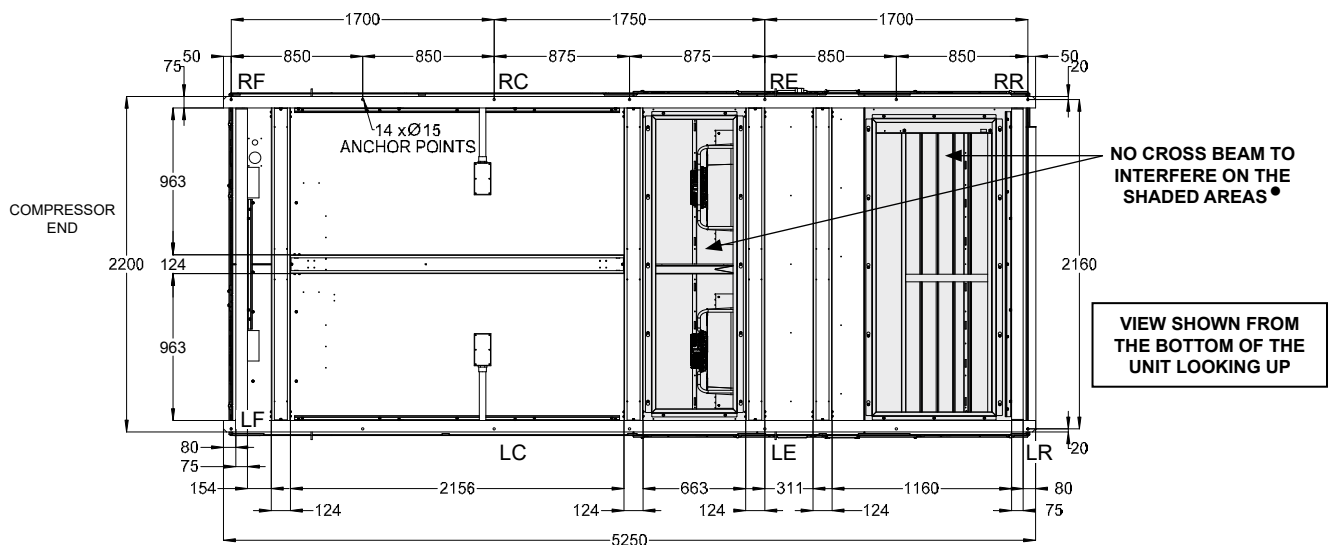

NOTES:

1. All dimensions are in mm unless specified. Do not scale drawing.
2. Refer to corresponding unit dimensional drawing for mounting hole details.
3. Drawings are available on ActronAir website, please contact ActronAir Technical Support for further information on 1800 119 229.



139.00 kW
3 Phase
Hercules

Outdoor Radiated

Sound Power Level (SWL)

Sound Pressure Level (SPL)

Airflow Settings	Sound Power Level dB(A)	Octave Band Centre Frequency (Hz), dB							Sound Pressure Level dB(A) at 3m
		125	250	500	1k	2k	4k	8k	
High *	76.1	74.6	71.8	73.9	71.3	67.6	64.5	62.8	59.1
Maximum **	83.2	84.4	79.4	80.6	77.5	74.6	72.7	70.7	66.2

* Measured at Standard Rated Condition, 35°C ambient.
 ** Measured at extreme ambient condition.

Indoor Outlet

Sound Power Level (SWL)

Sound Pressure Level (SPL)

Airflow Settings	Nominal Airflow Li/s	Sound Power Level dB(A)	Octave Band Centre Frequency (Hz), dB							Sound Pressure Level dB(A) at 3m
			125	250	500	1k	2k	4k	8k	
Minimum	5920	80.3	71.2	73.7	77.4	76.8	72.0	67.0	62.7	63.3
Nominal	7400	85.3	77.0	78.6	82.0	81.6	77.9	72.3	66.9	68.3
Maximum	8880	89.5	81.5	82.9	86.1	85.7	82.4	76.7	70.8	72.5

3 Phase
Hercules
139.00 KW

OUTDOOR RADIATED

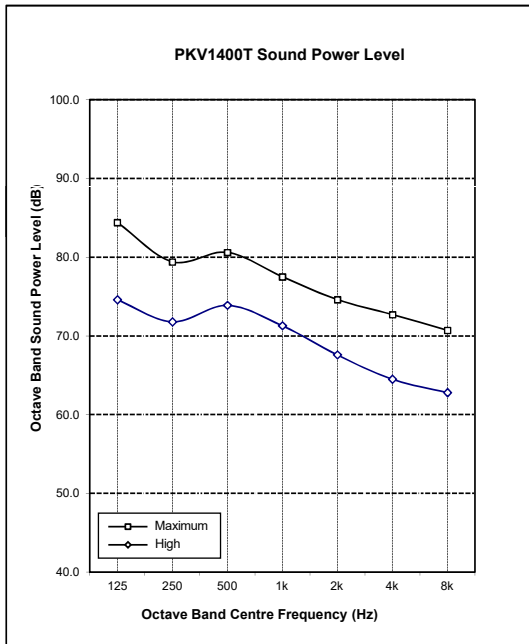

INDOOR OUTLET

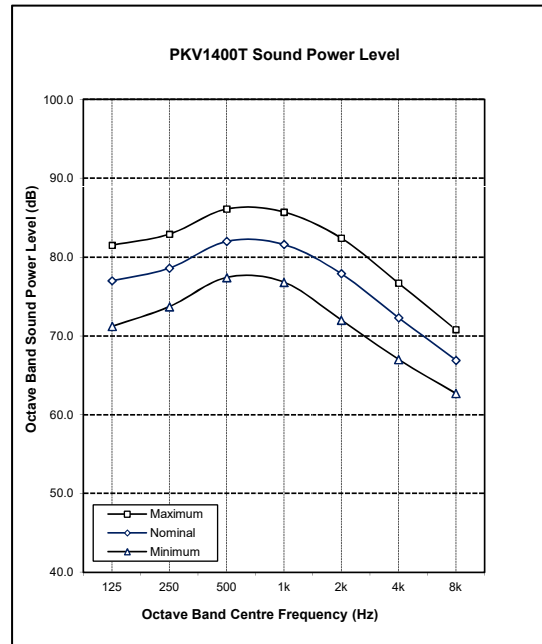

NOTE:

Radiated sound power levels are based on ISO 3743-1



139.00 kW
3 Phase
Hercules

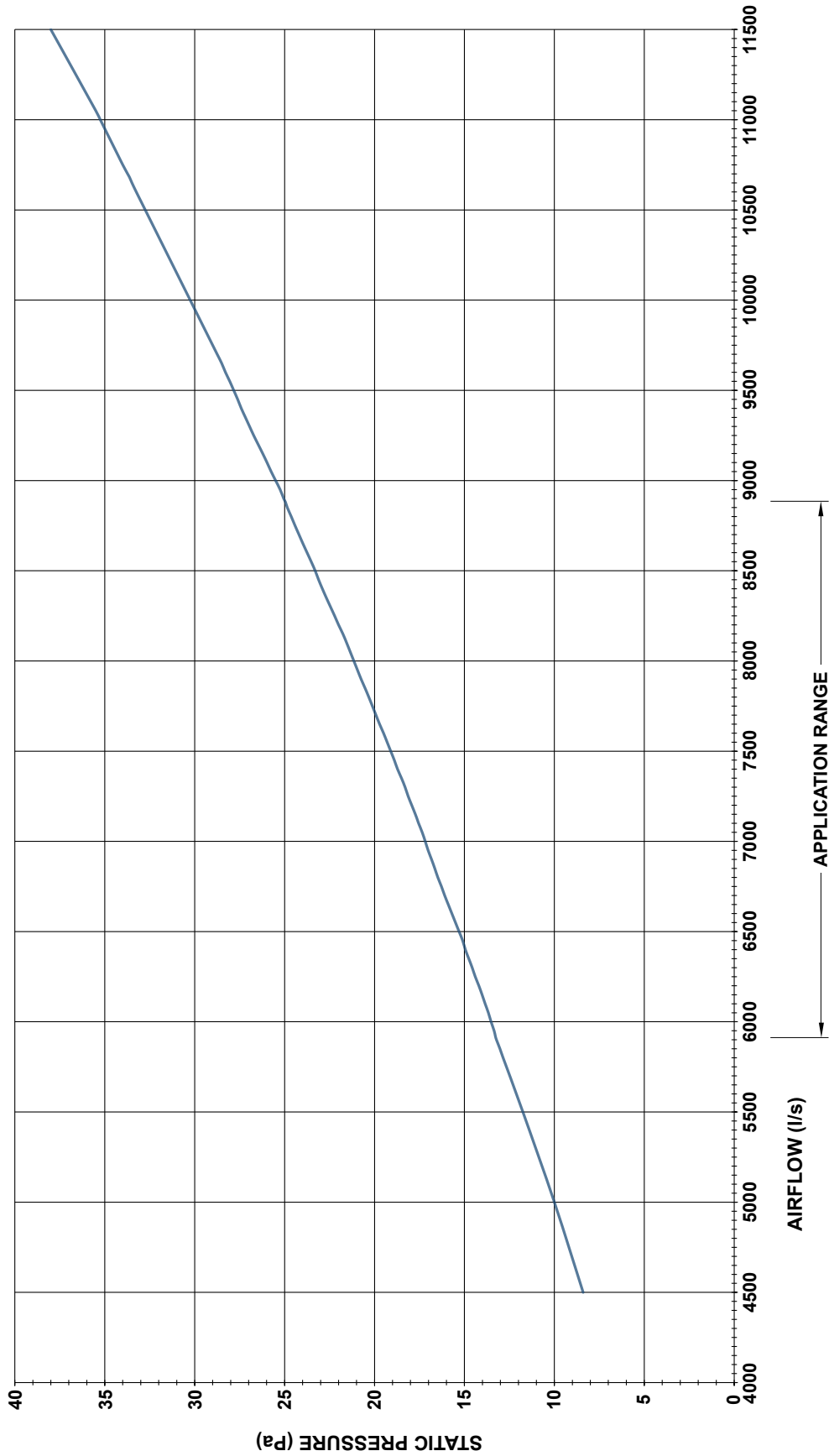

SPECIFICATIONS

PKV1400T

CONSTRUCTION		
CABINET	Top / Side Panels	1.2 mm Galvanised Steel
		1.15 mm Galvanised Steel
CHASSIS	Base Panel	1.6 mm Galvanised Steel
	C Channel/Hot Rolled	150x75x6 mm Hot Dipped Galv. Steel
	Bracket	1.9 mm Galvanised Steel
SURFACE FINISH		65 µm Baked Polyester Powder Coat

INSULATION		
TYPE	Evaporator Section	PE Foil Faced Insulation

SOUND LEVEL * dB(A)	
SOUND PRESS. - High / Maximum	59.1 / 66.2
SOUND POWER LEVEL - High / Max.	76.1 / 83.2
* Sound data is based on the outdoor fan's manufacturer sound level data.	

ELECTRICAL	
POWER SUPPLY - 50 Hz	400 Volts x 3 Phase + Neutral
VOLTAGE RANGE (min - max)	380 V - 440 V
FULL LOAD AMPS * - Phase 1	95.62
FULL LOAD AMPS * - Phase 2 and 3	95.0 / 95.0
RATED LOAD AMPS**	71.6
MAXIMUM INRUSH CURRENT	18.0
IP RATING	IP44

IMPORTANT - The local electricity authority may require limits on starting current and voltage drop, please check prior to purchase.

* Full Load Amps are based on Compressor and Fan Motor's maximum expected current.

** Rated Load Amps are measured and tested in accordance with AS/NZS3823.1.2.

CABLE SIZE & CIRCUIT BREAKER SIZE	
MAINS CIRCUIT BREAKER SIZE	100 A (140kW)

For minimum cable size, please refer to the latest edition of the AS/NZS 3000 "Australian/ New Zealand Wiring Rules" and AS/NZS 3008 "Electrical Installations - Selection of Cables, Part 1: Cables for alternating voltages up to and including 0.6/1kV" for more details.

OUTDOOR COIL	
TUBE TYPE	Copper - Rifle Bore
FIN TYPE	Aluminium - Wave
FACE AREA (m sq)	4.78 x 2
FIN SPACING (per m)	551
COIL COATING	Blue Hydrophilic Coat Coil Fin Protection

OUTDOOR FAN	
TYPE x NUMBER OF FANS	EC Axial Fan x 4
NUMBER OF BLADES PER FAN	5
INPUT kW (each)	2.46
MOTOR TYPE / DRIVE TYPE	Variable Speed EC Motor / Direct Drive
FAN SPEED CONTROL	Electronic Control
The standard EC outdoor fans fitted to this unit will accept up to 120Pa External Static Pressure.	

INDOOR COIL	
TUBE TYPE	Copper - Rifle Bore
FIN TYPE	Aluminium - Louvre
FACE AREA (m sq)	4.00 (face split)
FIN SPACING (per m)	551
COIL COATING	Blue Hydrophilic Coat Coil Fin Protection

INDOOR FAN	
TYPE x NUMBER OF FANS	Backward Curve Plug Fan x 4
INPUT kW (each)	1.25
MOTOR TYPE / DRIVE TYPE	Variable Speed EC Motor / Direct Drive
FAN SPEED CONTROL	Electronic Control

REHEAT COIL (OPTIONAL)	
TUBE TYPE	Copper -Rifle Bore
FACE AREA (m sq)	4.00
COIL COATING	Blue Hydrophilic Fin Protection +Complete Coil Treatment

COMPRESSOR		
TYPE x NUMBER PER UNIT	Variable Speed Scroll (Hermetic) x 2	
FULL LOAD AMPS (each)	35.14 A	
MAX. MUST TRIP AMPS (each)	45.0 A (Overload)	
STARTING METHOD	Soft Start	
MOTOR PROTECTION	Over-Current, Over-Modulation Protect.	
REFRIGERANT OIL	Type	POE Lubricant
	Charge (per comp.)	3.6 liters

REFRIGERATION SYSTEM	
REFRIGERANT TYPE	R-410A
EXPANSION CONTROL- (Type x Number per unit)	Bi-Flow EXV (Electronic Expansion Valve) x 2
FACTORY CHARGE (per comp.)	19,500 grams

PROTECTION DEVICES	
HIGH PRESSURE CUTOFF SWITCH	Non-adjustable (Automatic Reset)
LOW PRESSURE CUTOFF SWITCH	Non-adjustable (Automatic Reset)
COMPRESSOR MOTOR TEMP.	Internal Thermal Cut-Out
INDOOR FAN OVERLOAD	Full Electronic Monitoring
OUTDOOR FAN OVERLOAD	Internal Thermal Cut-Out
HIGH DISCHARGE TEMP. PROTECT.	Compressor Drive Controlled
SUMP HEATER WATTS (each comp.)	75

ELECTRIC CONTROLS	
DEFROST METHOD	Reverse Cycle
DEFROST TYPE	Electronic Control
CONTROL CIRCUIT BREAKER	10.0 A
OPTIONAL THIRD PARTY CONTROLLER INPUTS	MODBUS 485 BACNET 485 BACNET TCP/IP

OPERATING RANGE			
It is essential that the unit is correctly sized for the application and operates within its recommended range of operating conditions as shown below.			

MODE	RANGE	INDOOR AIR INTAKE TEMPERATURE	OUTDOOR AIR INTAKE TEMPERATURE
		30°C DB/22°C WB	50°C DB
Cooling	Max.	30°C DB/22°C WB	50°C DB
	Min.	20°C DB/16°C WB	15°C DB
Heating	Max.	24°C DB	19.5°C DB/18°C WB
	Min.	16°C DB	-10°C WB
Low Ambient Cooling	Std.	Max.	29°C DB/19°C WB
		Min.	20°C DB/15°C WB
			50°C DB
			-5°C DB to 5°C DB

AIR FILTER PROVISION	
All return air, including outside air, must have adequate filters supplied and fitted by the installing contractor. Return Air Filters are to be located in the return air filter retainer in the unit or in accessible location between the return air grille and the unit.	
No outside air filter retainer has been provided in the unit.	

AIR FILTER RAILS FITTED (Filters not Supplied)		
AIR FILTER DISPOSABLE - 2 small + 2 large air filters per row (Not Supplied)		
AIR FILTERS (Small)	Material	30/30 Pleated Cotton Synthetic Blend - G4
	Size - H x W x T	495 x 495 x 95 (actual air filter dimensions)
	Quantity	8 pcs.
AIR FILTERS (Large)	Material	30/30 Pleated Cotton Synthetic Blend - G4
	Size - H x W x T	495 x 594 x 95 (actual air filter dimensions)
	Quantity	8 pcs.

3 Phase

Hercules

139.00 KW



WIRING DIAGRAM

PKV1400T

139.00 kW
3 Phase
Hercules

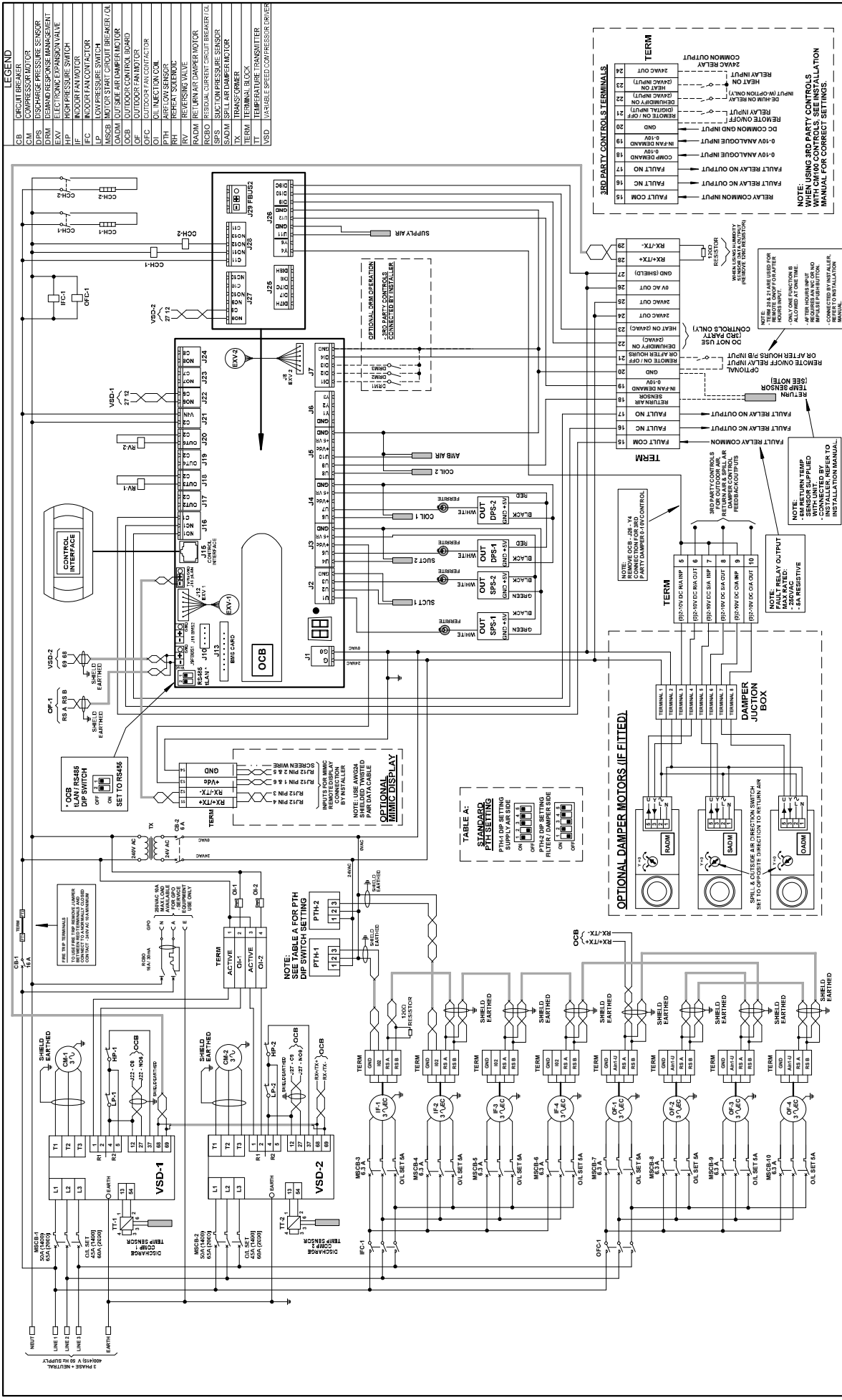

LEGEND

CB	CIRCUIT BREAKER
CM	COMPRESSOR MOTOR
DPS	DISCHARGE PRESSURE SENSOR
DRM	DRUM PRESSURE MANAGEMENT
EV	ELECTRIC EXPANSION VALVE
HP	HIGH PRESSURE SWITCH
IPC	INDOOR FAN MOTOR
IFC	INDOOR FAN CONTACTOR
MSCB	MOTOR START CIRCUIT BREAKER (ON)
OMD	OUTDOOR MOTOR DAMPER MOTOR
OCB	OUTDOOR CONTROL BOARD
OF	OUTDOOR FAN MOTOR
OFK	OUTDOOR FAN CONTACTOR
OL	OL OIL LEVEL CONTROL
OLK	OL OIL LEVEL CONTACTOR
RV	REVERSING VALVE
RDM	RETURN AIR DAMPER MOTOR
RCBD	RESIDUAL CURRENT CIRCUIT BREAKER (ON)
SPS	SOLUTION PRESSURE SENSOR
TX	TRANSFORMER
TRM	TERMINAL BLOCK
TRM	TERMINAL BLOCK
VSD	VARIABLE SPEED COMPRESSOR DRIVER

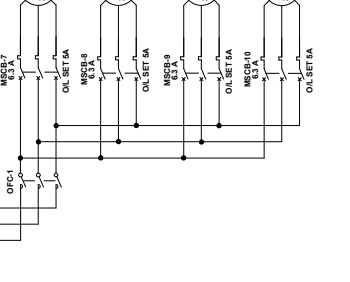
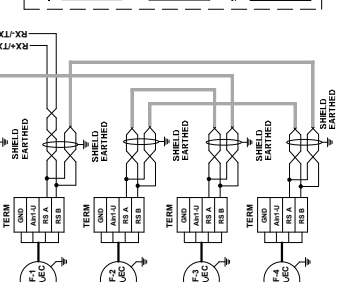
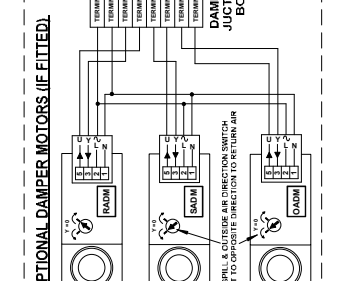
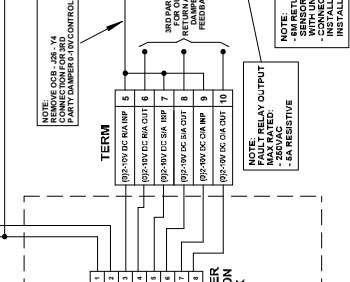
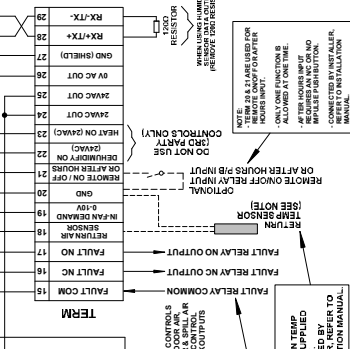
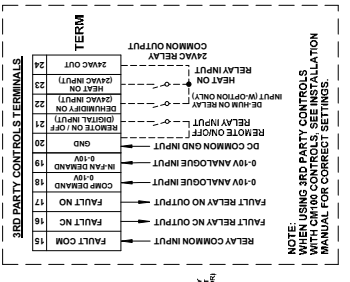

<p>ActronAir</p> <p>This drawing remains the intellectual property of Actron Engineering Pty Ltd. Reproduction, modification and/or distribution are prohibited without written consent.</p>		<p>Base Model No: PKV1400/2000T</p> <p>Variation Code: STANDARD</p> <p>Description: DUAL VARIABLE SPEED COMPRESSOR CONTROL SYSTEM WIRING DIAGRAM WITH CM100 OUTDOOR BOARD, CONTROL INTERFACE & EBM EC FAN CONTROL</p>	<p>Revision: A</p> <p>Size: A3</p>
<p>Rev. A</p> <p>Description: ORIGINAL</p>	<p>By: PCR</p> <p>Date: 08-11-2021</p>	<p>Drawn: OH</p> <p>Date: 08-11-2021</p>	<p>Approved: RL</p> <p>Date: 09-11-2021</p>
		<p>Drawing No: 0515-7013</p>	

NOTES:

- ONLY AIR HANDING SECTION OF THE UNIT IS SHOWN.
- ALL VIEWS ARE SHOWN FROM THE RETURN AIR END OF THE UNIT.
- ALL FLANGES ARE OUTSIDE DIMENSIONS.
- ALL FLANGES ARE RAW EDGE EXCEPT FOR DOWN SUPPLY (D - OPTION) AND DOWN RETURN (B - OPTION) WHICH HAVE A 26mm RETURN FLANGE (PLEASE SEE DETAILS).

LEGEND FOR SUPPLY POSITIONS

- D = DOWN SUPPLY 1953 x 553
- L = LEFT HAND SUPPLY 1503 x 633
- R = RIGHT HAND SUPPLY 1903 x 503
- T = TOP SUPPLY 1903 x 503

LEGEND FOR RETURN POSITIONS

- B = BOTTOM RETURN 1953 x 803
- EL = LH VERTICAL RETURN 1903 x 753
- ER = RH VERTICAL RETURN 1903 x 753
- SL = LH SIDE RETURN 1903 x 753
- SR = RH SIDE RETURN 1903 x 753
- TT = TOP RETURN 1903 x 753

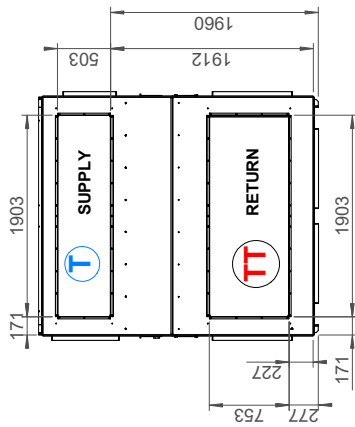

TOP VIEW

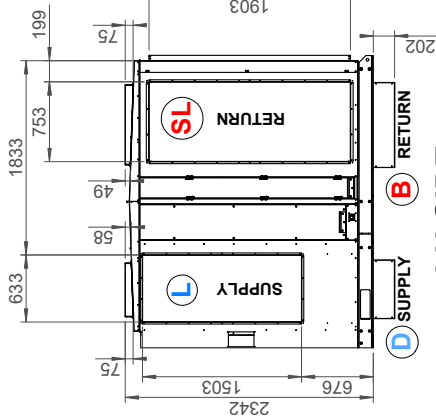

LH SIDE

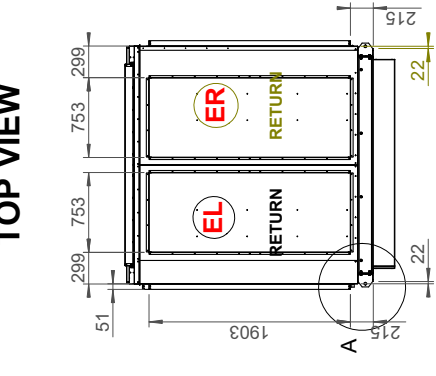

END VIEW

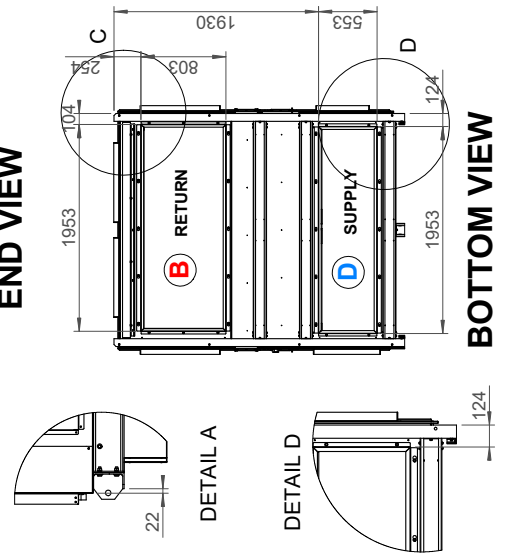

BOTTOM VIEW

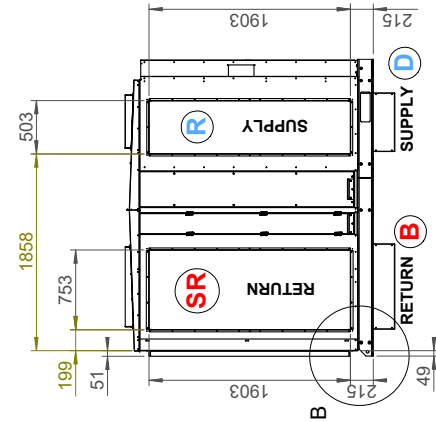

RH SIDE

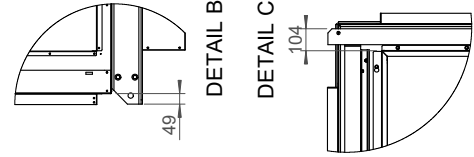

DETAIL B

DETAIL C

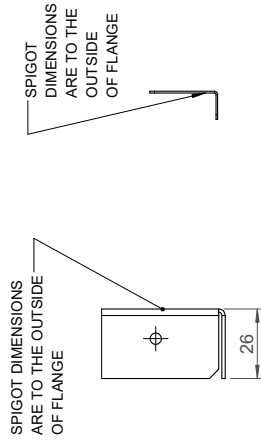

DOWN SUPPLY & DOWN RETURN FLANGE DETAIL

RAW EDGE FLANGE DETAIL

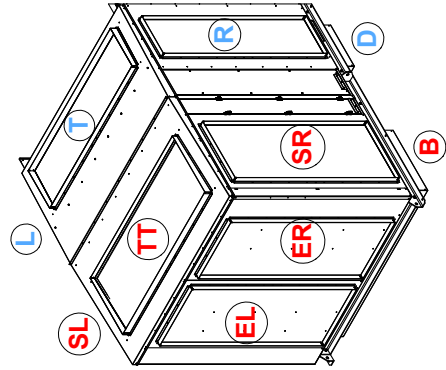

139.00 kW
3 Phase
Hercules

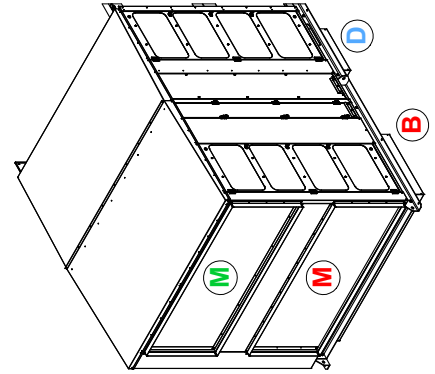
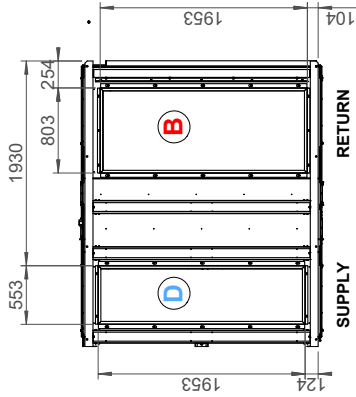
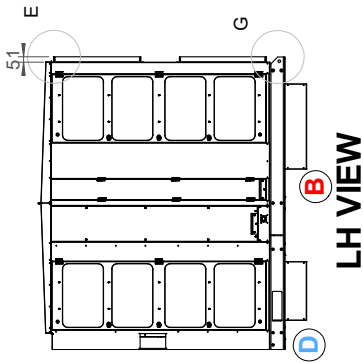
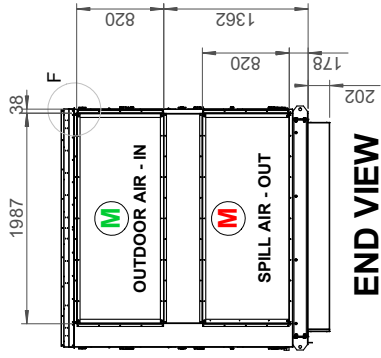

DETAILS OF SPIGOTS
FOR ECONOMISER
WITH SPILL-AIR
"-M" VARIATION

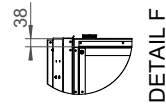
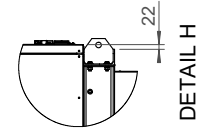
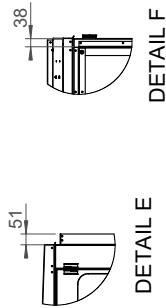
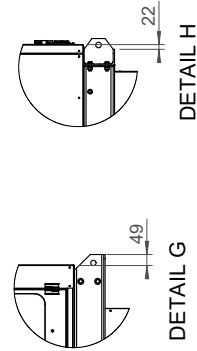
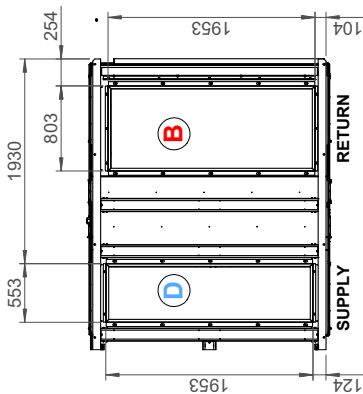
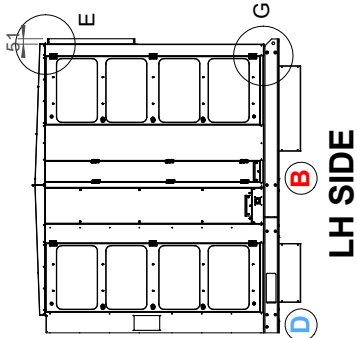
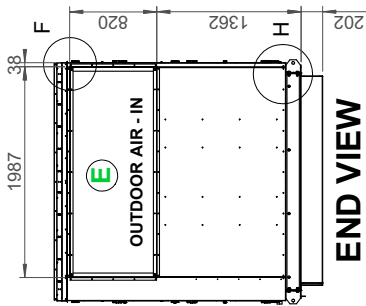

DETAILS OF SPIGOTS
FOR ECONOMISER
WITHOUT SPILL-AIR
"-E" VARIATION

