

WALL HUNG SPLIT SYSTEM



1 Phase
1 Stage
5.00 kW

UNIT FEATURES

- Reverse Cycle Wall Hung Split System
- Mono & Multi Compatible Heads
- Rotary Compressor
- Superior Operating Range:
 - Cooling: up to 50°C DB
 - Heating: down to -25°C DB
- Adjustable Airflow
- 3D Multi-Directional Airflow
 - Up / Down Auto Swing
 - Left / Right Auto Swing
- Louvre Position Memory
- Fan Speed: Auto, Low, Medium and High
- Powder Coated Panels - Outdoor Unit
- Hydrophilic Indoor and Outdoor Coil Protection
- BIO Filter
- Self-Diagnosis and Auto Protection
- Fire Proof Electrical Box - Indoor & Outdoor Units

UNIT OPTION

- Left or Right Hand Drain Connection

CONTROL FEATURES

- Digital Display
- Auto Restart After Power Failure
- Timer ON/OFF Operation
- Remote ON/OFF Input
- Manual ON/OFF Operation
- 12-Speed Indoor Fan
- 5-Speed Outdoor Fan
- Sleep Mode
- Turbo Mode
- Quiet Operation
- Dry Mode Operation
- Demand Response Ready
- 1W Standby Power Consumption
- Auto Defrost Function
- Follow Me Function
- Mute Operation
- Self Clean Function
- Fault Alarm Output

UNIT COMPLIANCE

- MEPS 2012
- Demand Response AS4755.3.1

SPECIFICATION SUMMARY

OUTDOOR UNIT MODEL	WRC-050AS	
INDOOR UNIT MODEL	WRE-050AS	
	NETT	
⁽¹⁾⁽²⁾ COOLING CAPACITY (kW) - NOMINAL (MIN - MAX)	5.00 (2.00 - 6.00)	
⁽¹⁾⁽³⁾ HEATING CAPACITY (kW) - NOMINAL (MIN - MAX)	5.15 (1.55 - 6.18)	
⁽¹⁾⁽⁴⁾ COOLING INPUT POWER (kW)	1.32	
⁽¹⁾⁽⁴⁾ HEATING INPUT POWER (kW)	1.32	
⁽¹⁾⁽²⁾ EER	3.79	
⁽¹⁾⁽³⁾ COP	3.90	
⁽⁵⁾ INDOOR AIRFLOW (l/s) - LOW/MED/HIGH	211/264/306	
MOISTURE REMOVAL (l/hr)	1.8	
INDOOR SOUND PRESS. LEVEL dB(A) - LOW/MED/HIGH	37 / 42 / 44	
OUTDOOR SOUND PRESS. LEVEL @ 1M dB(A)	55	
⁽⁶⁾ OUTDOOR SOUND POWER LEVEL dB(A)	63	
POWER SUPPLY	220 - 240V / 1Ph+N / 50 Hz	
INDOOR UNIT WIRING METHOD	Hard wire to Outdoor	
⁽¹⁾ RATED LOAD AMPS - COOLING / HEATING	5.9 / 5.9	
⁽⁷⁾ FULL LOAD AMPS	8.5	
⁽⁸⁾ CIRCUIT BREAKER AND CABLE AMPS	10.0	
WEIGHT (kg) - INDOOR / OUTDOOR	10.4 / 40.5	
OUTDOOR OPERATING RANGE (°C)	COOLING	-15 to 50
	HEATING	-25 to 30

⁽¹⁾ Measured and tested in accordance with AS/NZS 3823.1.1.
⁽²⁾ At 27°C DB / 19°C WB entering air temperatures and 35°C ambient.
⁽³⁾ At 20°C DB entering air temperature and 7°C DB / 6°C WB ambient.
⁽⁴⁾ input power includes indoor fan kW.
⁽⁵⁾ Max. - Min. airflow application range.
⁽⁶⁾ Determination of Sound Power Levels of Noise Sources per AS1217.2.
⁽⁷⁾ Full Load Amps are based on compressor and fan motors' maximum expected current.
⁽⁸⁾ See Specifications sheet for cable size and circuit breaker size details.

Note: Use input power to estimate running cost.



5.00 kW
1 Phase 1 Stage

COOLING PERFORMANCE

INDOOR CONDITIONS		OUTDOOR TEMPERATURE (°C - DB)						
		21	25	30	35	40	45	50
21°C - DB 15°C - WB	Nett Capacity, kW	4.87	4.78	4.70	4.47	4.26	3.13	2.23
	Sensible Heat Capacity, kW	3.96	3.89	3.82	3.63	3.47	2.54	1.82
	Power Input, kW	0.51	0.83	1.02	1.24	1.39	1.40	1.42
24°C - DB 17°C - WB	Nett Capacity, kW	5.18	5.08	5.00	4.75	4.54	3.33	2.38
	Sensible Heat Capacity, kW	4.21	4.14	4.07	3.87	3.69	2.71	1.93
	Power Input, kW	0.52	0.86	1.05	1.28	1.43	1.45	1.46
27°C - DB 19°C - WB	Nett Capacity, kW	5.45	5.35	5.26	5.00	4.78	3.50	2.50
	Sensible Heat Capacity, kW	4.44	4.35	4.28	4.07	3.89	2.85	2.04
	Power Input, kW	0.54	0.89	1.08	1.32	1.48	1.49	1.51
32°C - DB 23°C - WB	Nett Capacity, kW	6.10	5.99	5.89	5.60	5.35	3.92	2.80
	Sensible Heat Capacity, kW	4.97	4.88	4.80	4.56	4.35	3.19	2.28
	Power Input, kW	0.59	0.98	1.19	1.46	1.63	1.65	1.66

HEATING PERFORMANCE

INDOOR CONDITIONS		OUTDOOR TEMPERATURE							
		-15°C D -16°C W	-7°C D -8°C W	-5°C D -6°C W	0°C D -1°C W	4°C D 3°C W	7°C D 6°C W	12°C D 11°C W	24°C D 18°C W
15°C - DB	Nett Capacity, kW	2.02	3.66	4.04	4.47	4.76	5.77	6.34	5.32
	Power Input, kW	0.74	1.21	1.06	1.30	1.46	1.45	1.59	1.33
18°C - DB	Nett Capacity, kW	1.93	3.50	3.86	4.27	4.54	5.51	6.06	5.08
	Power Input, kW	0.72	1.16	1.02	1.26	1.41	1.40	1.54	1.29
20°C - DB	Nett Capacity, kW	1.80	3.27	3.61	3.99	4.25	5.15	5.67	4.75
	Power Input, kW	0.68	1.10	0.97	1.19	1.33	1.32	1.45	1.21
22°C - DB	Nett Capacity, kW	1.75	3.17	3.50	3.87	4.12	5.00	5.50	4.61
	Power Input, kW	0.69	1.12	0.99	1.21	1.36	1.35	1.48	1.24
27°C - DB	Nett Capacity, kW	1.57	2.85	3.14	3.47	3.70	4.48	4.93	4.13
	Power Input, kW	0.69	1.13	0.99	1.22	1.36	1.35	1.49	1.24

PIPE LENGTH CORRECTION MULTIPLIER

	5m	10m	20m	30m
COOLING	1.000	0.985	0.954	0.924
HEATING	1.000	0.990	0.971	0.952

NOTES:

- No allowance has been made for the effect of indoor fan motor.
- Selection tables are based on nominal airflows.
Correction factors must be applied for selection away from these conditions.
- Pipe length correction multipliers are based on horizontal pipe runs.

UNIT DIMENSIONS

WRC-050AS / WRE-050AS

OUTDOOR UNIT: WRC-050AS

NOMINAL DIMENSION (H x W x D)
= 702 x 845 x 363
USE M10 BOLT FOR FEET MOUNTING

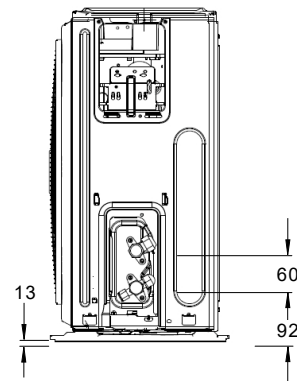
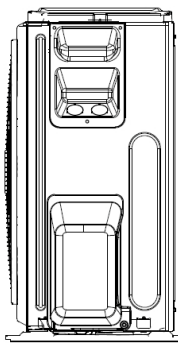
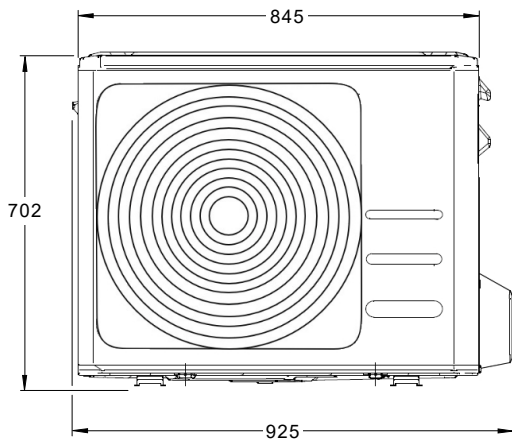
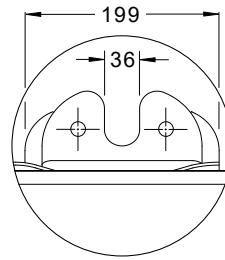
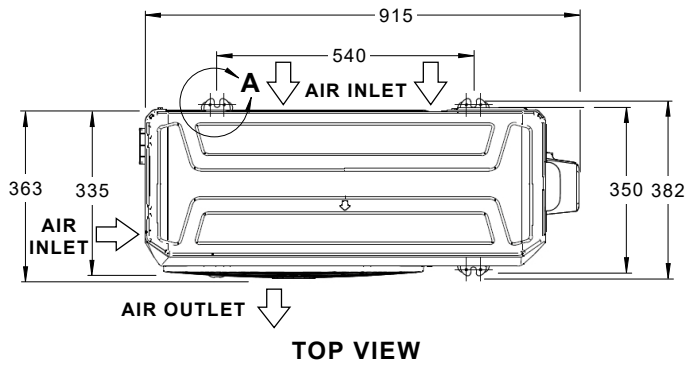

1 Phase
1 Stage
5.00 kW

PLEASE NOTE THAT UNDER ALL CIRCUMSTANCES, CONDENSER AIR MUST NOT RECIRCULATE BACK ONTO CONDENSER COIL.

NOTES:

1. All dimensions are in mm unless specified.
2. Do not scale drawing.
3. Refer Pipe Connection Details on Specifications Sheet.
4. Suggested Service Clearances are based on conditions that the spaces are free from obstructions and walkway passage of 1000mm is available.
5. Minimum service access areas are responsibilities of the installer.

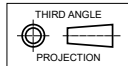

SERVICE ACCESS AREAS & AIRFLOW ALLOWANCES

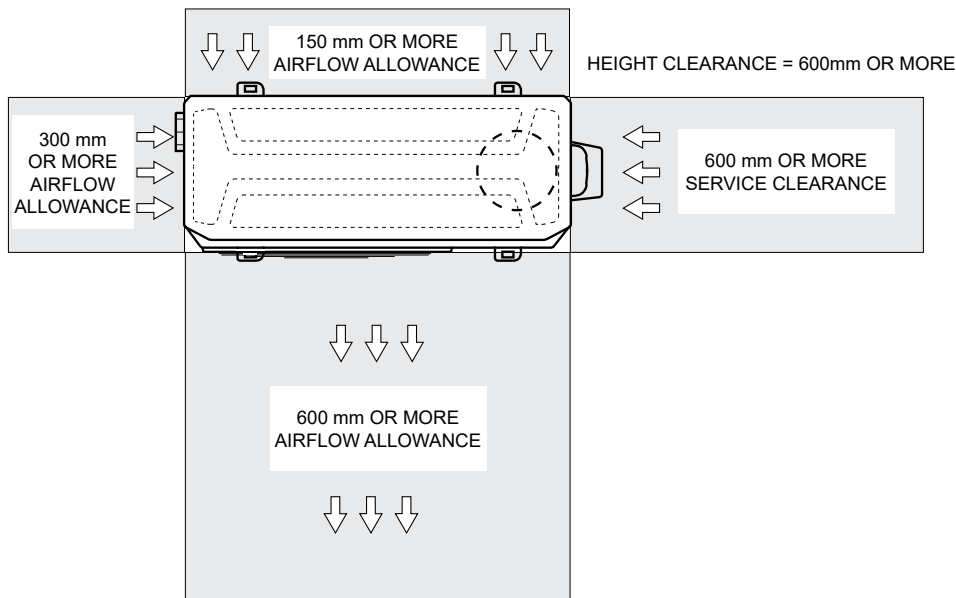

UNIT DIMENSIONS

WRC-050AS / WRE-050AS

E INDOOR UNIT: WRE-050AS

NOTES:

1. All dimensions are in mm unless specified.
2. Do not scale drawing.
3. Refer Pipe Connection Details on Specifications Sheet.
4. Minimum service access areas are responsibilities of the installer.

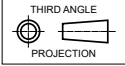

NOMINAL DIMENSION (H x W x D)
= 325 x 964 x 222

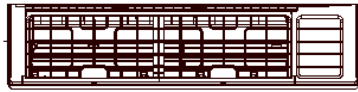

TOP VIEW

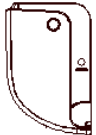

LHS VIEW

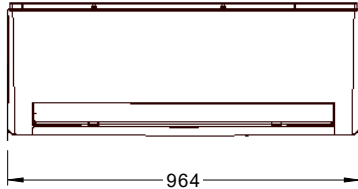

FRONT VIEW

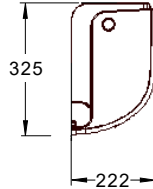

RHS VIEW



BOTTOM VIEW

MOUNTING DETAILS

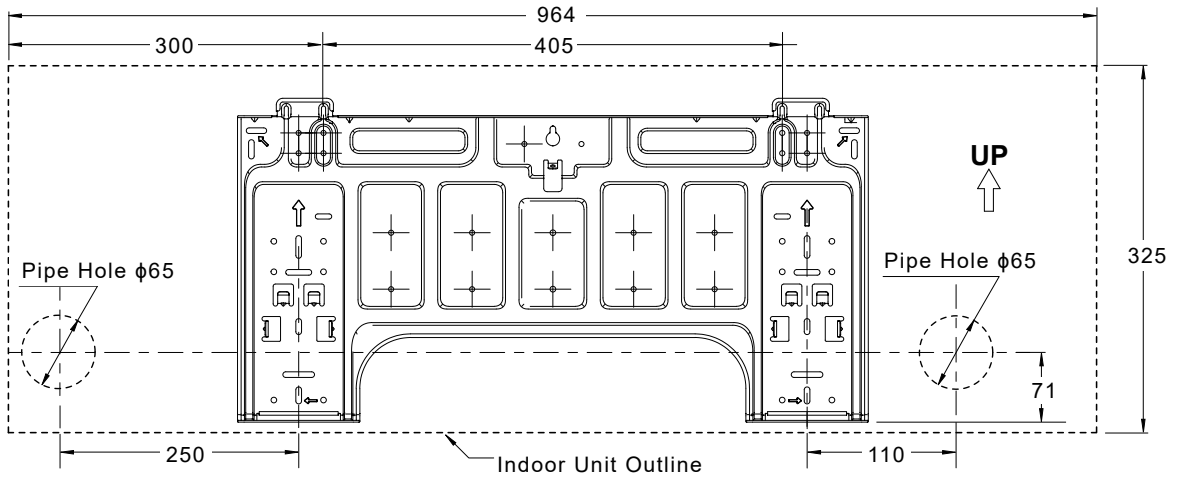

MOUNTING CLEARANCES

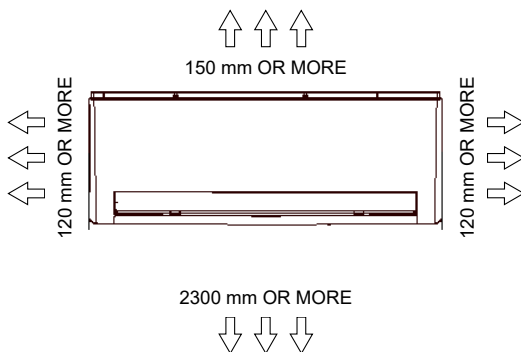

5.00 kW
1 Phase 1 Stage

SPECIFICATIONS

WRC-050AS / WRE-050AS

1 Phase
1 Stage

5.00 kW

UNIT DIMENSIONS		
OUTDOOR DIMENSIONS	Depth	363 mm
	Height	702 mm
	Width	845 mm
INDOOR DIMENSIONS	Depth	222 mm
	Height	325 mm
	Width	964 mm

ELECTRICAL		
POWER SUPPLY	220 - 240 Volts / 1 Ph + N / 50Hz	
WIRING METHOD	Hard wire to outdoor	
FULL LOAD AMPS*	Total	8.5
FULL LOAD AMPS	Indoor	0.275
RATED LOAD AMPS**	Cooling	5.9
	Heating	5.9
IP RATING	Outdoor	IP24
	Indoor	IP20

IMPORTANT - The local electricity authority may require limits on starting current and voltage drop, please check prior to purchase.

*Full Load Amps are based on Compressor and Fan Motor's maximum expected current.

**Rated Load Amps are measured and tested in accordance with AS/NZS3823.1.1.

CABLE SIZE & CIRCUIT BREAKER SIZE	
Suggested minimum cable size should be used as a guide only, refer to AS/NZS 3000 "Australian/New Zealand Wiring Rules" for more details.	
Cable Size (Supply Mains)	1.5 mm ² (SUGGESTED MINIMUM)
Cable Size (Indoor to Outdoor Wire)	1.0 mm ² (3 Core + Earth)
Circuit Breaker Size	10.0Amps

OUTDOOR COIL	
TUBE TYPE	Copper Ø7mm, inner groove tube
FIN TYPE	Hydrophylic Aluminium
FACE AREA	0.49 m ²
FIN SPACING	1.4 mm
ROWS	2

OUTDOOR FAN	
NUMBER OF FANS x TYPE	1 x Axial
INPUT (W)	180
FAN SPEED (rpm) - Hi/Med/Lo	850 / 700 / 500
AIRFLOW (l/s)	639

INDOOR COIL	
TUBE TYPE	Copper Ø7mm, inner groove tube
FIN TYPE	Hydrophylic Aluminium
FACE AREA	0.22 m ²
FIN SPACING	1.2 mm
ROWS	2

INDOOR FAN	
NUMBER OF FANS x TYPE	1 x Centrifugal
INPUT (W)	110
AIRFLOW - Hi/Med/Lo	306 / 264 / 211(l/s)

AIR FILTERS	
Air filters are supplied standard and pre-fitted.	

COMPRESSOR	
NUMBER PER UNIT x TYPE	1 x Rotary Compressor
STARTING METHOD	DC Inverter Starter
INPUT (W)	1035
REFRIGERANT OIL (TYPE / CHARGE)	ESTER OIL VG74 / 450ml
PROTECTION	External Thermal Cut-Out

REFRIGERATION SYSTEM	
REFRIGERANT TYPE	R-410A
FACTORY CHARGE	1575 g
PRE-CHARGE LENGTH	10 m
ADD'L. REFRIGERANT CHARGE	15 g / m
DESIGN PRESSURE (High/Low)	4.2 / 1.5 MPa

INTERCONNECTING PIPE RUN	
MAX PIPE LENGTH	30 m
MIN PIPE LENGTH	3 m
MAX. VERTICAL LENGTH	20 m (Included in Max. Pipe Length)

FIELD PIPE SIZES	
Liquid Pipe	6.35 mm (1/4")
Gas Pipe	12.7 mm (1/2")

PIPE CONNECTIONS		
Indoor	Liquid Pipe	6.35 mm (1/4")
	Gas Pipe	12.7 mm (1/2")
Outdoor	Liquid Pipe	6.35 mm (1/4")
	Gas Pipe	12.7 mm (1/2")
CONNECTION TYPE		Flare Nut

ELECTRIC CONTROLS	
DEFROST METHOD	Reverse Cycle
WALL CONTROLLER CABLE (INCLUDED WITH WALL CONTROLLER)	4 Core (0.75mm ²) Shielded Data Cable

OPERATING RANGE			
It is essential that the unit is correctly sized for the application and operates within its recommended range of operating conditions as shown below.			
MODE	RANGE	INDOOR OPERATING TEMPERATURE	OUTDOOR AIR INTAKE TEMPERATURE
COOLING	Max.	32°C DB	50°C DB
	Min.	17°C DB	-15°C DB
HEATING	Max.	30°C DB	30°C DB
	Min.	0°C DB	-25°C DB



WRC-050AS (OUTDOOR)

5.00 kW
1 Phase
1 Stage

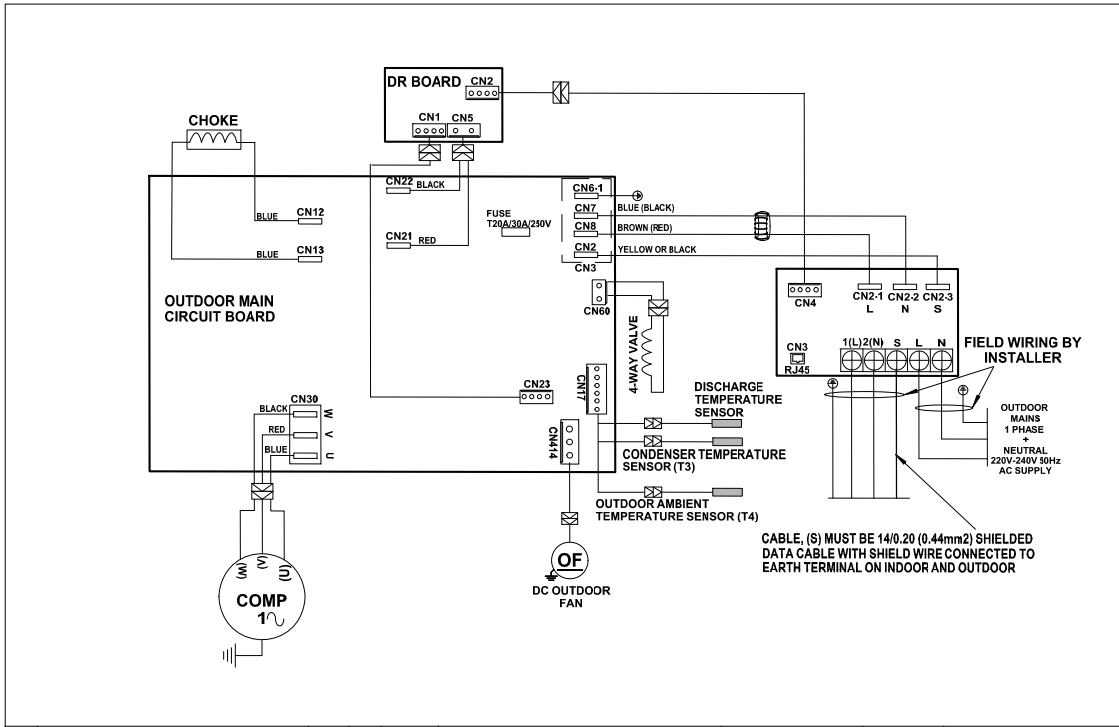

					Base Model No:	WRC-050AS/ WRC-071AS	Variation Code:	Variation:	STANDARD					
					Description:	OUTDOOR WIRING DIAGRAM - SERENE								
Rev.	Description	PCR	By	Date	Drawn:	NDL	Date:	31-07-2017	Drawing No:	WD3014	Revision:	C	Size:	A4
A	ORIGINAL				Approved:	WG	Date:	05-04-2018						

WRE-050AS (INDOOR)

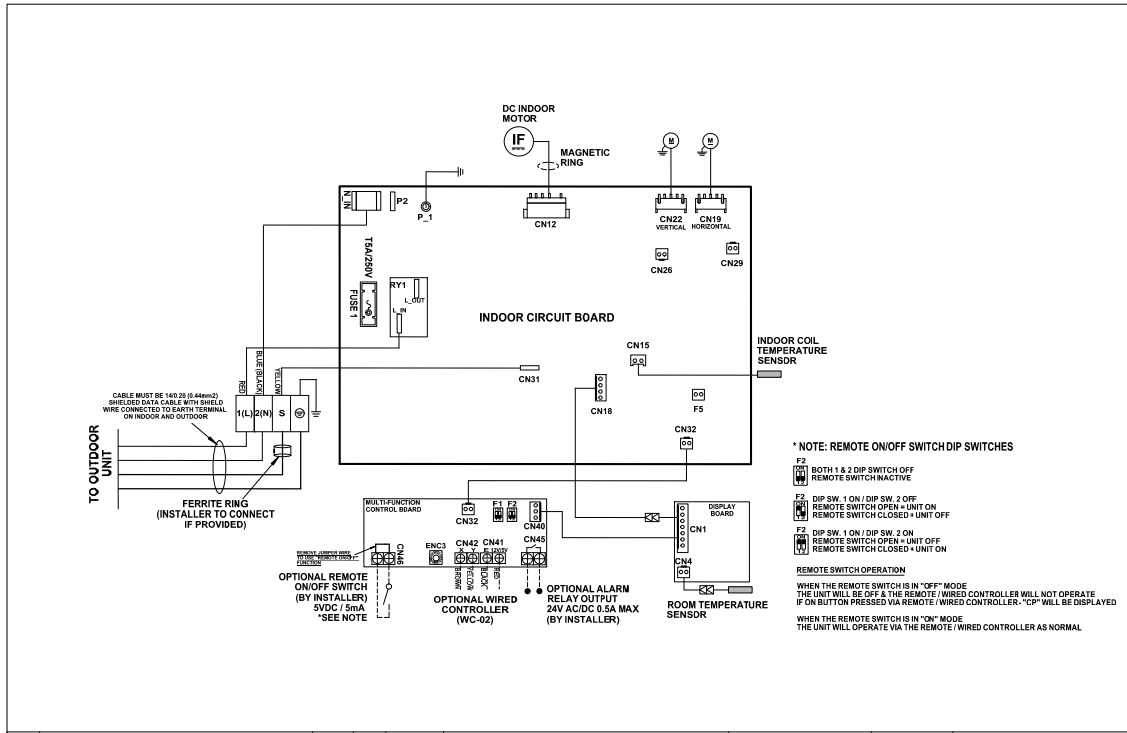

					Base Model No:	WRE-035AS/WRE-050AS/ WRE-071AS/WRE-080AS	Variation Code:	Variation:	STANDARD					
					Description:	INDOOR WIRING DIAGRAM - SERENE								
Rev.	Description	PCR	By	Date	Drawn:	NDL	Date:	31-07-2017	Drawing No:	WD3002	Revision:	C	Size:	A4
A	ORIGINAL				Approved:	WG	Date:	05-04-2018						

