

SPLIT DUCTED UNIT

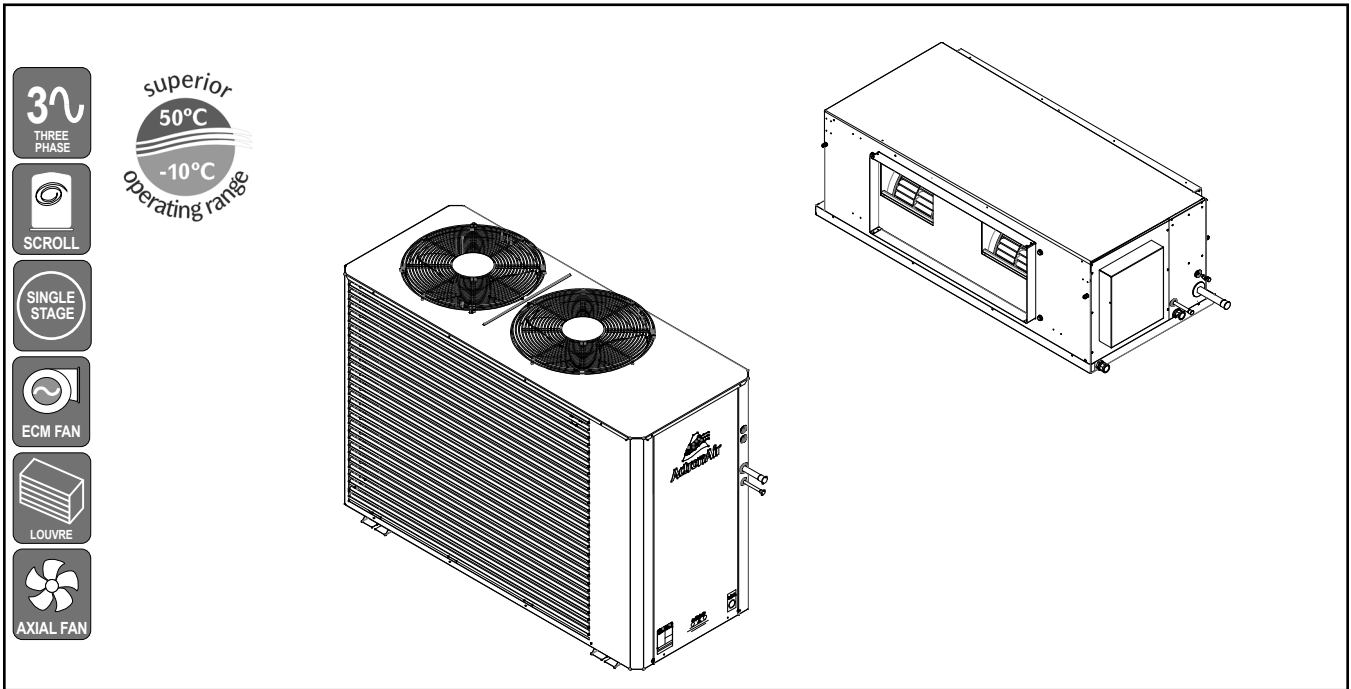

3 Phase
1 Stage
19.69 kW

UNIT FEATURES

- Compliant Scroll Compressor
- EMC High Efficiency Indoor Fan Motor
- Three Speed Outdoor Fan
- Adaptive Demand Defrost
- 20 m Cat5E Cable included
- Low Ambient Cooling Operation to +5 degree
- Fault and Run Indication - Relay Output
- Up to 3 Wall Controllers and 3 Remote Temperature Sensors
- Ready for up to 8 zones
- Hydrophilic Blue Fin Coil Coat Protection - Indoor & Outdoor Coils
- Integral Fan Coil Safety Tray with Drain Kit
- Pre-charged with R-410A Refrigerant
- Powder Coated Outdoor Unit With Louvred Coil Guard

CONTROL OPTIONS AND FEATURES

ActronAir LR7-1/LC7-2

- Available in White or Grey
- 7-day Programmable Controller with 2 Events per Day
- 24-hour ON/OFF Timer
- Temperature Setback
- After Hours Time (LC7 Only)
- Auto, Heat & Cool Modes
- Auto/Continuous Indoor Fan Operation
- Optional 2nd and 3rd Controllers with Mimic Logic
- On-Board Temperature Sensor

ActronAir Neo

- 7" Colour Touch Screen Master Controller
- In-built Wi-Fi and Blue-Tooth
- Neo Connect App
- On-Board Temperature, Humidity and Proximity Sensor
- Optional wireless Zone Sensor
- Available in White or Black

ActronAir Group Control

ActronAir BMS ICUNO-MOD (Modbus 485)

3RD PARTY CONTROL OPTIONS

- Manual Inputs (Heat, Cool and Fan Operation)
- Analogue Input (Fan Only)

PLENUMS (Optional)

- Supply Air Plenums are Available

UNIT OPTIONS

- Three Phase Soft Starter
- Additional Full Coil Coat Protection
- Outdoor Drain Tray
- Horizontal Discharge Condenser
- Vertical Evaporator

SPECIFICATION SUMMARY

OUTDOOR UNIT MODEL	CRA200T	
INDOOR UNIT MODEL	EVA200S	
	(1) TOTAL	(2) NETT
(3) COOLING CAPACITY (kW)	19.69	19.06
(3) SENSIBLE CAPACITY (kW)	16.84	16.20
(4) HEATING CAPACITY (kW)	19.27	19.90
(5) COOLING INPUT POWER (kW)	5.76	
(5) HEATING INPUT POWER (kW)	5.63	
EER	3.42	3.31
COP	3.44	3.53
(6) INDOOR AIRFLOW (l/s) - MIN. / NOMINAL / MAX.	900 / 1000 / 1150	
(7) OUTDOOR SOUND PRESS. LEVEL @ 3M dB(A) - LOW / MEDIUM / HIGH	50.4 / 51.3 / 53.1	
OUTDOOR SOUND POWER LEVEL dB(A) - LOW / MEDIUM / HIGH	69.8 / 70.7 / 73.1	
POWER SUPPLY - OUTDOOR	400V / 3Ph+N / 50 Hz	
POWER SUPPLY - INDOOR	230V / 1Ph+N / 50 Hz	
(2) RATED LOAD AMPS - OUTDOOR / INDOOR / TOTAL	9.0 / 4.5 / 13.5	
(8) FULL LOAD AMPS - OUTDOOR / INDOOR / TOTAL	13.9 / 5.9 / 19.8	
(9) CIRCUIT BREAKER AND CABLE AMPS	20.0	
APPROXIMATE STARTING AMPS	64.5	
WEIGHT (kg) - INDOOR / OUTDOOR	72 / 158	

(1) Total Capacities are based on unit rating excluding indoor fan (kW).

(2) Measured and tested in accordance with AS/NZS 3823.1.2.

(3) At 27°C DB / 19°C WB entering air temperatures and 35°C ambient.

(4) At 20°C DB entering air temperature and 7°C DB / 6°C WB ambient.

(5) Input power includes indoor fan (kW).

(6) Max. - Min. airflow application range.

(7) Sound levels are determined in an anechoic chamber and may differ once the unit is installed due to ambient conditions.

(8) Full Load Amps are based on compressor and fan motors' maximum expected current.

(9) See Specifications sheet for cable size and circuit breaker size details.

Note: Use input power to estimate running cost.



CAPACITY SELECTION DATA

CRA200T / EVA200S

COOLING PERFORMANCE

AIR ENTERING		TOTAL CAPACITY kW	TOTAL SENSIBLE CAPACITY - kW AT DB TEMPERATURE ONTO INDOOR COIL - °C											
OUTDOOR DB - °C	INDOOR WB - °C		20	21	22	23	24	25	26	27	28	29	30	
25	16	20.60	12.88	14.11	15.32	16.51	17.69	18.66						
	17	20.60	11.67	12.85	14.08	15.30	16.51	17.68	18.73					
	18	21.02	10.39	11.64	12.83	14.06	15.28	16.47	17.69	18.79	19.79			
	19	21.55	9.08	10.36	11.64	12.80	14.03	15.25	16.45	17.66	18.79	19.84	20.76	
	20	22.04	7.73	9.04	10.32	11.60	12.76	13.99	15.20	16.42	17.62	18.78	19.87	
	21	22.67		7.70	8.98	10.29	11.54	12.70	13.96	15.16	16.36	17.58	18.75	
30	22	23.24		7.68	8.94	10.24	11.51	12.76	13.90	15.11	16.33	17.53		
	16	19.88	12.52	13.74	14.95	16.13	17.25	18.11						
	17	19.85	11.32	12.50	13.74	14.94	16.13	17.27	18.32					
	18	20.22	10.04	11.31	12.46	13.70	14.91	16.11	17.29	18.39	19.25			
	19	20.64	8.74	10.02	11.28	12.45	13.68	14.89	16.09	17.26	18.40	19.42		
	20	21.14	7.42	8.71	10.00	11.25	12.42	13.65	14.86	16.06	17.25	18.41	19.47	
35	21	21.76		7.37	8.66	9.95	11.22	12.39	13.60	14.82	16.05	17.21	18.37	
	22	22.30		7.33	8.61	9.90	11.17	12.33	13.55	14.78	15.99	17.17		
	16	19.11	12.13	13.35	14.56	15.72	16.77							
	17	19.11	10.94	12.12	13.33	14.54	15.71	16.83	17.80					
	18	19.36	9.68	10.92	12.09	13.32	14.52	15.70	16.86	17.94				
	19	19.69	8.37	9.65	10.91	12.06	13.29	14.51	15.70	16.84	17.97	16.21		
40	20	20.22	7.05	8.34	9.62	10.88	12.04	13.26	14.47	15.66	16.83	17.98	19.02	
	21	20.72		7.03	8.31	9.59	10.83	12.02	13.21	14.44	15.62	16.81	17.96	
	22	21.23			6.99	8.27	9.53	10.81	11.96	13.17	14.38	15.59	16.79	
	16	18.17	11.67	12.90	14.08	15.21	16.15							
	17	18.18	10.44	11.66	12.89	14.06	15.24	16.29						
	18	18.31	9.24	10.49	11.64	12.88	14.07	15.22	16.34	17.27				
45	19	18.60	7.94	9.22	10.57	11.62	12.84	14.06	15.22	16.37	17.41			
	20	19.04	6.64	7.93	9.20	10.44	11.60	12.81	14.02	15.20	16.35	17.45	18.36	
	21	19.51		6.61	7.89	9.17	10.41	11.57	12.77	13.99	15.18	16.32	17.46	
	22	20.01			6.58	7.86	9.12	10.38	11.54	12.72	13.94	15.13	16.32	
	16	17.15	11.17	12.41	13.56	14.64								
	17	17.17	9.96	11.18	12.38	13.57	14.69	15.61						
50	18	17.17	8.78	9.96	11.16	12.37	13.57	14.70	15.75					
	19	17.43	7.51	8.75	9.93	11.15	12.36	13.55	14.71	15.81	16.66			
	20	17.82	6.20	7.47	8.74	9.98	11.13	12.32	13.52	14.69	15.82	16.84		
	21	18.25		6.17	7.45	8.71	9.96	11.10	12.30	13.48	14.69	15.82	16.89	
	22	18.76			6.14	7.41	8.69	9.92	11.07	12.28	13.46	14.64	15.78	
	16	16.03	10.65	11.88	12.98	13.91								
50	17	16.05	9.45	10.64	11.86	13.00	14.05							
	18	16.05	8.28	9.44	10.63	11.84	13.01	14.11						
	19	16.17	7.01	8.26	9.43	10.63	11.82	13.01	14.13	15.13				
	20	16.49	5.72	6.98	8.24	9.42	10.61	11.80	12.97	14.13	15.20			
	21	16.89		5.69	6.97	8.23	9.44	10.58	11.76	12.97	14.14	15.22	16.19	
	22	17.33			5.66	6.93	8.19	9.42	10.56	11.75	12.94	14.10	15.22	

19.69 kW
3 Phase 1 Stage

HEATING PERFORMANCE

WB TEMP ON OD COIL - °C	TOTAL HEATING CAPACITY - kW AT DB ENTERING INDOOR - °C									
	16		18		20		22		24	
	TH	IH	TH	IH	TH	IH	TH	IH	TH	IH
-10	11.80	11.33	11.75	11.28	11.70	11.23	11.63	11.17	11.58	11.12
-8	12.59	11.96	12.52	11.90	12.46	11.83	12.39	11.77	12.32	11.71
-6	13.40	12.60	13.32	12.52	13.25	12.46	13.22	12.42	13.15	12.36
-4	14.26	13.12	14.16	13.03	14.13	13.00	14.04	12.92	13.96	12.84
-2	15.21	13.54	15.11	13.45	15.01	13.35	14.90	13.26	14.82	13.19
0	16.12	14.19	16.00	14.08	15.93	14.02	15.82	13.92	15.71	13.83
2	17.03	15.50	16.90	15.38	16.76	15.25	16.64	15.14	16.52	15.04
4	18.03	18.03	17.84	17.84	17.74	17.74	17.62	17.62	17.49	17.49
6	19.07	19.07	18.90	18.90	18.75	18.75	18.60	18.60	18.48	18.48
8	20.15	20.15	19.97	19.97	19.80	19.80	19.65	19.65	19.49	19.49
10	21.27	21.27	21.08	21.08	20.90	20.90	20.73	20.73	20.56	20.56
12	22.43	22.43	22.23	22.23	22.03	22.03	21.82	21.82	21.64	21.64
14	23.63	23.63	23.41	23.41	23.19	23.19	22.97	22.97	22.77	22.77
16	24.88	24.88	24.62	24.62	24.39	24.39	24.15	24.15	23.92	23.92
18	26.16	26.16	25.89	25.89	25.62	25.62	25.35	25.35	25.10	25.10

TH - Total Heating Capacity (kW).
IH - Integrated Heating Capacity (kW)
Includes defrost losses.

AIRFLOW CORRECTION MULTIPLIER

% VARIATION	-10%	-5%	NOMINAL	5%	10%	15%
INDOOR AIRFLOW (l/s)	900	950	1000	1050	1100	1150
TOTAL COOLING	0.985	0.991	1.000	1.008	1.015	1.022
SENSIBLE COOLING	0.946	0.972	1.000	1.028	1.055	1.082
HEATING FACTOR	0.995	0.998	1.000	1.002	1.004	1.006

NOTES:

- No allowance has been made for the effect of indoor fan motor.
- Selection tables are based on nominal airflows. Correction factors must be applied for selection away from these conditions.

* PIPE LENGTH CORRECTION MULTIPLIER - 7/8" (22.22 mm)

	5 m	10 m	20 m	30 m	40 m	50 m	60 m
COOLING	1.000	0.995	0.988	0.974	0.963	0.953	0.946
HEATING	1.000	1.000	1.000	1.000	1.000	1.000	1.000

* PIPE LENGTH CORRECTION MULTIPLIER - 3/4" (19.05 mm)

	5 m	10 m	20 m	30 m	40 m	50 m	60 m
COOLING	1.000	0.982	0.957	0.937	0.915	0.895	0.876
HEATING	1.000	1.000	1.000	1.000	1.000	1.000	1.000

* Correction Multipliers are based on horizontal pipe runs.



DIMENSIONS

CRA200T

OUTDOOR UNIT CRA200T

OVERALL NOMINAL DIMENSION (H x W x L)
= 1045 x 1460 x 580

PLEASE NOTE THAT UNDER ALL CIRCUMSTANCES, CONDENSER AIR MUST NOT RECIRCULATE BACK ONTO CONDENSER COIL. KEEP ALL CLEARANCES FREE OF ANY OBSTRUCTIONS

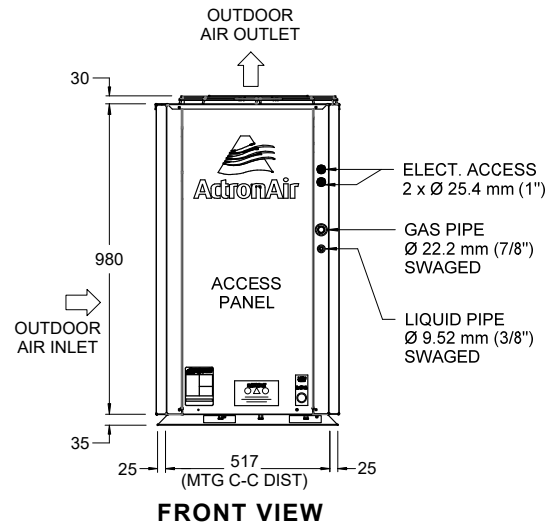
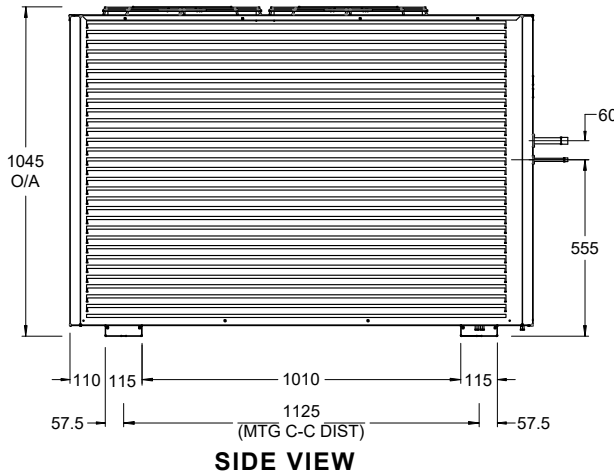
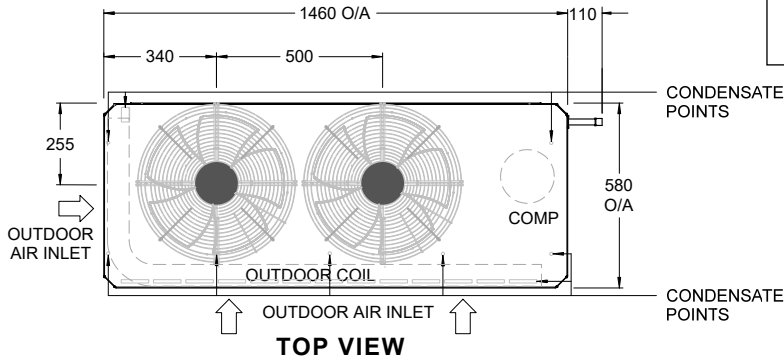

3 Phase
1 Stage
19.69 kW

UNIT MODEL NUMBER	UNIT WEIGHT (kg)	CORNER WEIGHT (kg)			
		A	B	C	D
CRA200T	158	15	59	38	46

MINIMUM SERVICE ACCESS AREAS AND AIRFLOW CLEARANCES

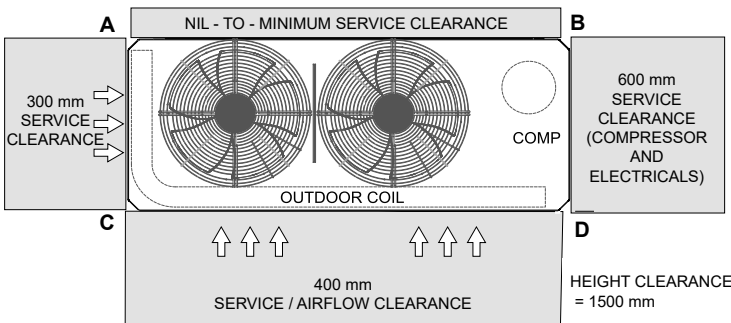

NOTES:

- Do not scale drawing. All dimensions are in mm unless specified. Refer to corresponding unit dimensional drawing for mounting hole details.
- Service Access Areas and Spaces for Airflow Clearances given above are suggested minimum based on the condition that the spaces around the units are free from any obstructions and a walkway passage of 1000mm between the units or between the unit and the outside perimeter is available.
- Minimum service access areas and spaces for airflow clearances are responsibilities of the installer, ActronAir will not be held liable for any extra charges incurred due to lack of access and space for airflow.
- Under all circumstances, condenser air must not recirculate back onto condenser coil. Keep all clearance free of any obstructions.
- STACKING OF UNITS: Ensure that minimum airflow and clearances are met.
- Refer to pipe Connection Details on Specifications Sheet.
- MTG C-C DIST = Mounting Centre to Centre Distance.
- Use M12 bolt for feet mounting.



DIMENSIONS AND FAN CURVE

EVA200S

INDOOR UNIT EVA200S

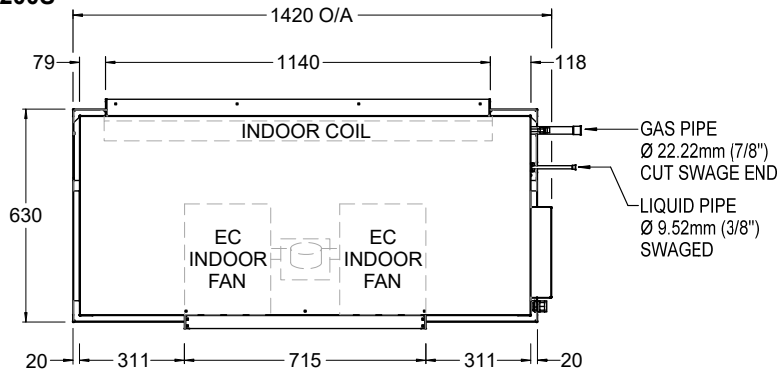

TOP VIEW

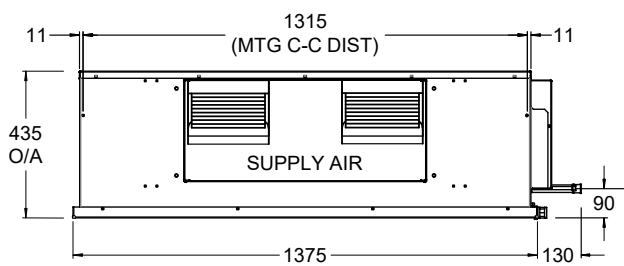

FRONT VIEW

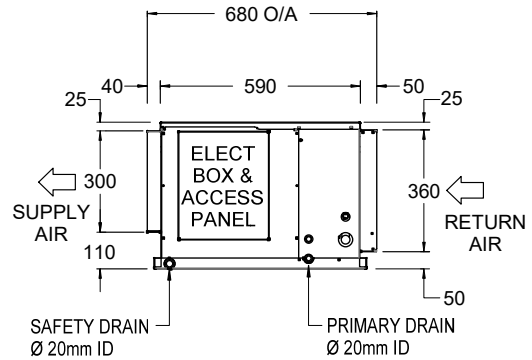

SIDE VIEW

OVERALL NOMINAL DIMENSION (H x W x L)
= 435 x 1420 x 680
SUPPLY DUCT (H x W) = 300 x 715
RETURN DUCT = 360 x 1140
DRAIN CONNECTION = 20 mm ID

UNIT MODEL NUMBER	UNIT WEIGHT (kg)
EVA200S	72

MINIMUM SERVICE ACCESS AREAS AND AIRFLOW CLEARANCES

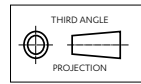
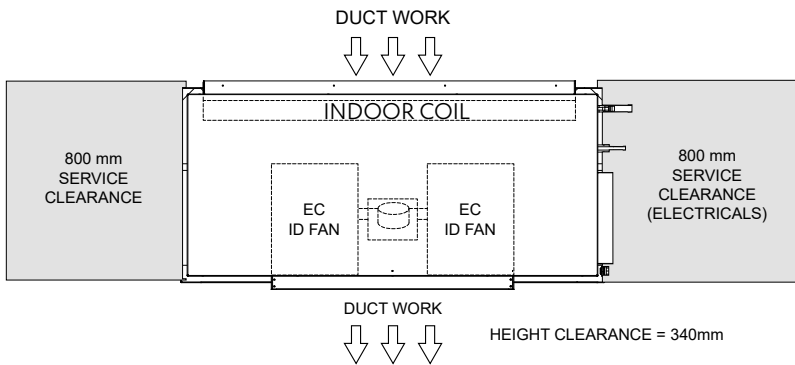

NOTES:

1. Do not scale drawing. All dimensions are in mm unless specified.
2. Service Clearances given are suggested minimum based on the condition that the spaces around the units are free from any obstructions and a walkway passage of 1000mm between the units or between the unit and the outside perimeter is available.
3. Minimum service access clearances are responsibilities of the installer, ActronAir will not be held liable for any extra charges incurred due to lack of access.

INDOOR UNIT FAN CURVE *

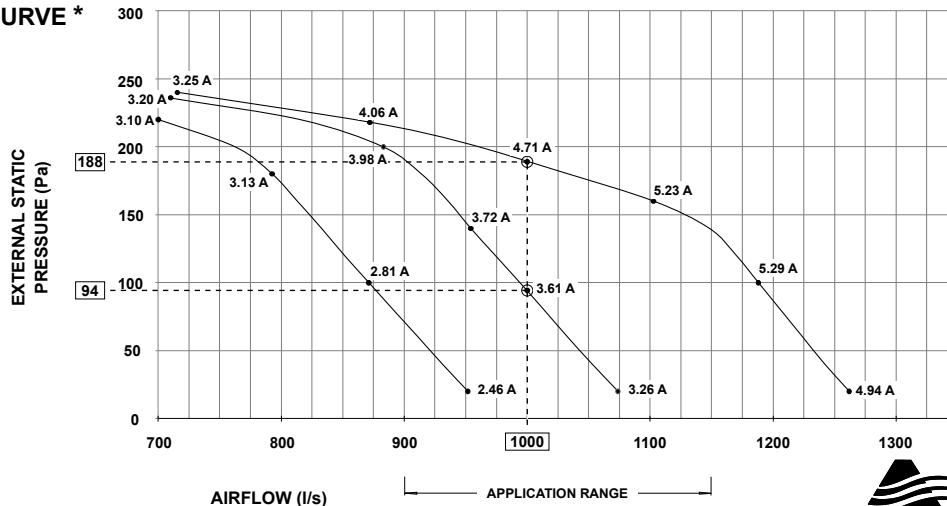

* Performance Fan Curve shown is at Dry Coil Condition for FD 9x7S - 3/4Hp EC Fan.



19.69 kW
3 Phase 1 Stage

INDOOR UNIT - WITH 3RD PARTY CONTROL

AIRFLOW (l/s)	EXTERNAL STATIC PRESSURE (Pa)													
	50		75		100		125		150		175		200	
	% PWM	W	% PWM	W	% PWM	W	% PWM	W	% PWM	W	% PWM	W	% PWM	W
900	52	357	53	395	55	438	58	481	62	522	65	563	69	608
925	53	371	55	420	58	459	62	510	65	549	67	586	70	641
950	55	402	58	446	62	489	65	533	67	577	70	624	75	669
975	58	423	62	476	65	515	67	553	70	608	74	666	MOTOR / BLOWER LIMIT	
1000	62	454	65	499	68	547	70	593	73	641	75	682		
1025	65	476	68	533	70	571	73	625	76	672	80	719		
1050	68	511	70	557	73	607	76	659	79	708	85	755		
1075	70	534	73	586	76	640	79	697	82	740				
1100	73	570	76	624	79	680	82	728	84	750				
1125	76	604	79	656	82	712	84	750	85	769				
1150	79	644	82	694	85	749	88	806						

3 Phase
1 Stage
19.69 kW

NOTES:

W = Indoor Fan Power, Watts

PWM = Pulse Width Modulation Setting, % PWM

Default PWM Setting = 67% PWM (Medium Speed) at 100 Pa

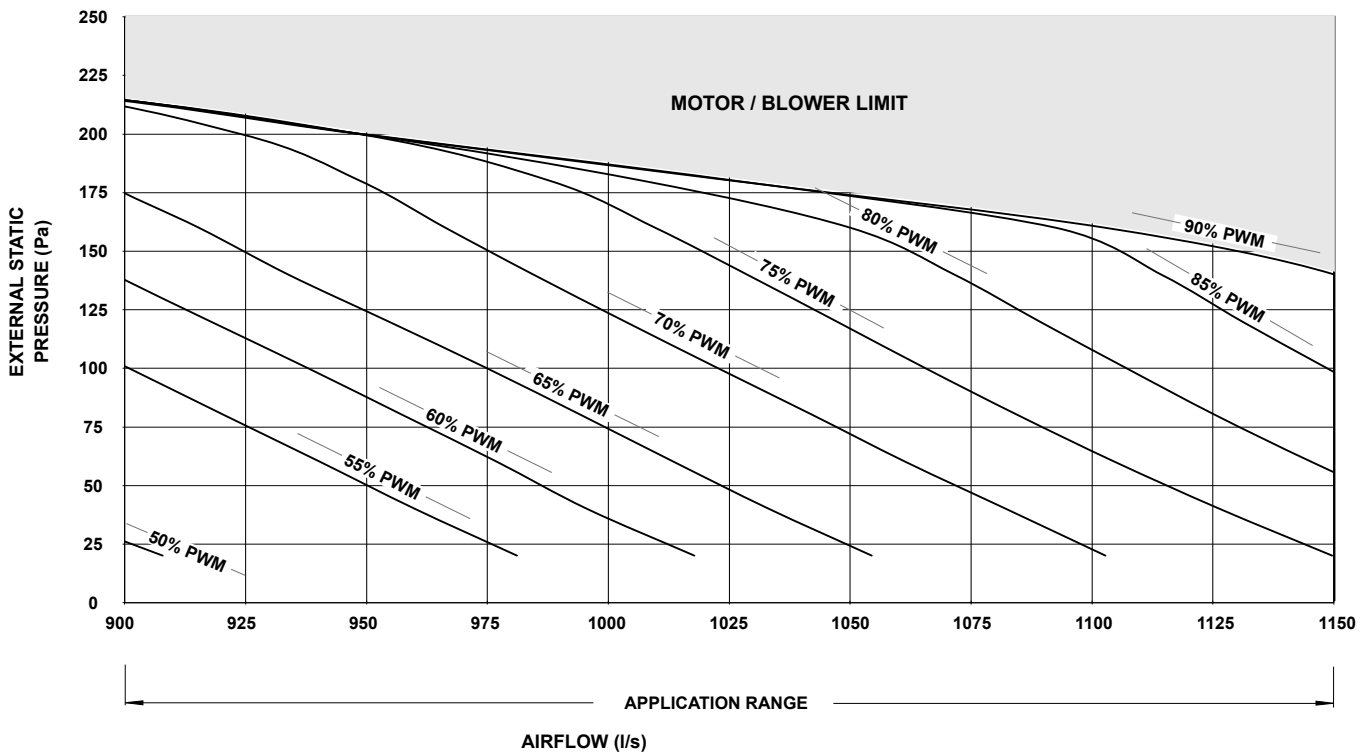

Outdoor Radiated

Sound Power Level (SWL)

Fan Speed	Sound Power Level dB(A)	Octave Band Centre Frequency (Hz), dB						
		125	250	500	1k	2k	4k	8k
Low	69.8	67.9	61.5	69.7	65.8	56.3	50.5	47.1
Medium	70.7	70.1	64.7	70.5	66.2	57.6	52.4	47.6
High	73.1	74.6	71.3	72.5	67.7	61.5	56.1	49.0

Indoor Outlet

Sound Power Level (SWL)

Airflow Setting	Airflow l/s	Sound Power Level dB(A)	Octave Band Centre Frequency (Hz), dB						
			125	250	500	1k	2k	4k	8k
Nominal	1000	77.0	63.5	67.2	71.9	72.6	70.9	67.2	60.3

19.69 kW
3 Phase 1 Stage

OUTDOOR RADIATED

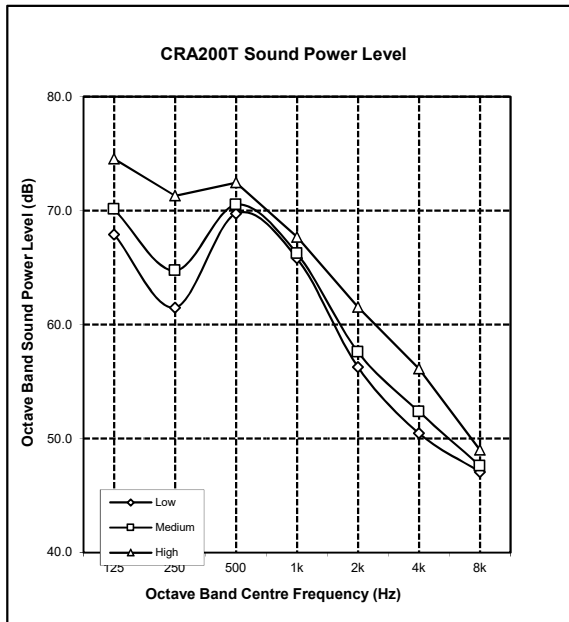

INDOOR OUTLET

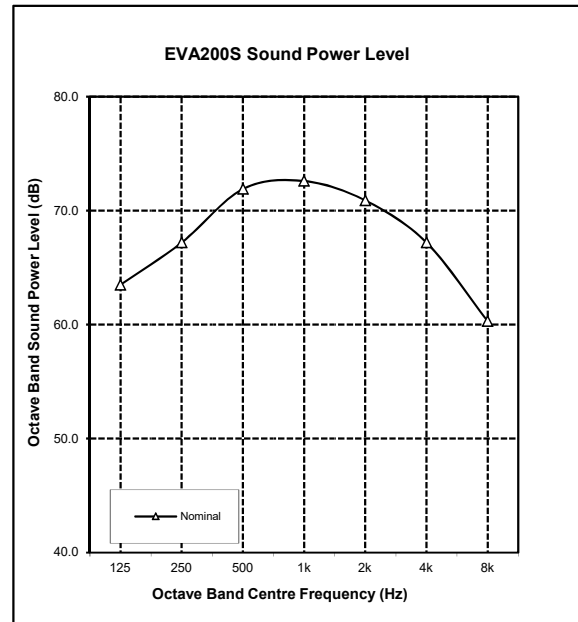

NOTE:

Radiated sound power levels are based on ISO 3743-1.



SPECIFICATIONS

CRA200T / EVA200S

CONSTRUCTION

CABINET (Indoor Unit)	0.5 - 0.9 mm Galvanized Steel
CABINET (Outdoor Unit)	0.9 - 1.2 mm Galvanized Steel
SURFACE FINISH (Outdoor Unit)	65 µ Baked Polyester Powder Coat

INSULATION (Indoor Unit)

TYPE	Foil Faced Polyethylene Expanded Polystyrene
------	-------------------------------------------------

ELECTRICAL

OUTDOOR UNIT	
Power Supply - 50 Hz	400 Volts x 3 Phase + N
Voltage Range (min - max)	380 V - 440 V
Full Load Amps*	13.9
Rated Load Amps**	9.0
Approximate Starting Amps	64.5
IP Rating	IP44
INDOOR UNIT	
Power Supply - 50 Hz	230 Volts x 1 Phase + N
Voltage Range (min - max)	216 V - 253 V
Full Load Amps*	5.9
Rated Load Amps**	4.5
IP Rating	IP20

OUTDOOR & INDOOR UNIT (TOTAL)	
Full Load Amps* - Phase 1	19.8
Full Load Amps* - Phase 2 & 3	12.8
Rated Load Amps**	13.5

IMPORTANT - The local electricity authority may require limits on starting current and voltage drop, please check prior to purchase.

* Full Load Amps are based on Compressor and Fan Motor's maximum expected current.
** Rated Load Amps are measured and tested in accordance with AS/NZS3823.1.2.

CABLE SIZE & CIRCUIT BREAKER SIZE

Suggested minimum cable size should be used as a guide only, refer to the accordance with the latest edition of the AS/NZS 3000 "Australian/New Zealand Wiring Rules" for more details.

Cable Size (main line)	2.5 mm ² (SUGGESTED MINIMUM)
Cable Size (indoor to outdoor wire)	1.0 mm ² (SUGGESTED MINIMUM)
Circuit Breaker (RCBO if applicable)	20.0 Amps

OUTDOOR COIL

TUBE TYPE	Copper - Rifle Bore
FIN TYPE	Aluminium - Wave
FACE AREA (m sqr)	1.64
FIN SPACING (per m)	472
COIL COATING	Hydrophilic Blue Fin Coil Coat Protection

OUTDOOR FAN

NUMBER OF FANS x TYPE	2 x Axial
NUMBER OF BLADES PER FAN	5
DIAMETER (mm)	450
OUTPUT kW (each)	0.145
MOTOR TYPE / DRIVE TYPE	6 Pole External Rotor / Direct
FAN SPEED CONTROL	3 Speed via Capacitor
The standard type outdoor fans fitted to this unit will accept up to 5 Pa of external static resistance.	

INDOOR COIL

TUBE TYPE	Copper - Rifle Bore
FIN TYPE	Aluminium - Louvre
FACE ARE (m sqr)	0.48
FIN SPACING (per m)	512
COIL COATING	Hydrophilic Blue Fin Coil Coat Protection

INDOOR FAN

NUMBER OF FANS x TYPE	1 x Twin Deck Centrifugal EC Fan
DIAMETER / WIDTH (mm)	240 x 180
OUTPUT (kW) / INPUT (kW)	0.56
MOTOR TYPE / DRIVE TYPE	Variable Speed EC Motor / Direct

COMPRESSOR

NUMBER PER UNIT x TYPE	1 x Scroll (Hermetic)
FULL LOAD AMPS	12.8
LOCKED ROTOR AMPS	64.5
STARTING METHOD	D.O.L. (optional soft starter)

REFRIGERATION SYSTEM

REFRIGERANT TYPE	R-410A
EXPANSION CONTROL	Direct Expansion Orifice
FACTORY CHARGE (grams)	7570
PRE-CHARGE LENGTH (metres)	15
ADDITIONAL REF. CHARGE (gm/m)	50 (for 3/8 Liq. Line) 100 (for 1/2 Liq. Line)

INTERCONNECTING PIPE RUN

MAX. PIPE LENGTH (metres)	0 - 20	20 - 60
MAX. VERTICAL LENGTH (metres)	20 (Included in Max. Pipe Length)	

FIELD PIPE SIZES

Liquid Pipe - mm (in.)	9.52 (3/8)	12.7 (1/2)
Gas Pipe - mm (in.)	22.22 (7/8) ▲	22.22 (7/8)

PIPE CONNECTIONS

Indoor	Liquid Pipe - mm (in.)	9.52 (3/8) swaged	9.52 (3/8) cut swage ▲▲
	Gas Pipe - mm (in.)	22.22 (7/8) swaged	22.22 (7/8) swaged
Outdoor	Liquid Pipe - mm (in.)	9.52 (3/8) swaged	9.52 (3/8) cut swage ▲▲
	Gas Pipe - mm (in.)	22.22 (7/8) swaged	22.22 (7/8) swaged

CONNECTION TYPE

Solder

▲ For short pipe run of 0-20 m or average 1-storey residential dwellings, 19.05 mm (3/4") Gas Field Pipe may be used in place of the recommended 22.22 mm (7/8"). Please refer to Capacity Selection Data & see Pipe Length Correction Multiplier for the drop in refrigeration capacity as a consequence of change in Gas Field Pipe diameter. Swaged end of Indoor and Outdoor Units' gas pipe to be cut in the field to fit ID to 19.05 mm (3/4") Field Pipe.

▲▲ Cut Swaged End in the field to fit OD to 12.7 mm (1/2") field pipe. Run 12.7 mm (1/2") field pipe the whole distance. Insulate both gas and liquid pipes separately.

FILTER DRIER

CONNECTION SIZE & TYPE	9.52 mm (3/8") or 12.7 mm (1/2") ODF Soldered Bi-Flow
FACTORY SUPPLIED / FITTED	No

PROTECTION DEVICES

HIGH PRESSURE CUTOUT SWITCH	Nonadjustable (Automatic Reset)
LOW PRESSURE CUTOUT SWITCH	Nonadjustable (Automatic Reset)
COMPRESSOR MOTOR TEMP.	Internal Thermal Cut-Out
INDOOR FAN OVERLOAD	Internal Thermal Cut-Out
OUTDOOR FAN OVERLOAD	Internal Thermal Cut-Out
SUMP HEATER WATTS *	30 W during Compressor Off Cycle
* Crankcase Heater is to be disconnected for pipe lengths 8 m or less.	

ELECTRIC CONTROLS

DEFROST METHOD	Reverse Cycle
DEFROST TYPE	Adaptive Demand Defrost
CONTROL CIRCUIT BREAKER	10.0 Amps
CONTROL FIELD WIRING	2 Core 14 / 0.20 Screened Cable
WALL CONTROLLER / SENSOR FIELD WIRING	Cat5e UTP (AWG 24) Data Cable

OPERATING RANGE

It is essential that the unit is correctly sized for the application and operates within its recommended range of operating conditions as shown below.

MODE	RANGE	INDOOR AIR INTAKE TEMPERATURE	OUTDOOR AIR INTAKE TEMPERATURE
Cooling	Max.	30°C DB / 22°C WB	50°C DB
	Min.	20°C DB / 16°C WB	5°C DB
Heating	Max.	24°C DB	21°C DB / 16°C WB
	Min.	16°C DB	-10°C DB

AIR FILTERS

All return air including fresh air must have adequate filters supplied and fitted by the installing contractor. Filters must be located in accessible location between the return air grille and the unit.
ActronAir does not supply or make any provisions for return air filter.

UNIT COMPLIANCE

- AS/NZS 3823.2 (MEPS)
- AS/NZS 4755.3.1 (DRM1, 2 and 3)
- AS/NZS CISPR 14.1 (EMC)
- AS/NZS 60335.2.40 (Safety)



WIRING DIAGRAM

CRA200T / EVA200S

19.69 kW
3 Phase 1 Stage

LEGEND

CB	CIRCUIT BREAKER
CM	COMPRESSOR MOTOR
CCH	CRANKCASE HEATER
CMC	COMPRESSOR MOTOR CONTACTOR
ECF	EMI FILTER
HP	HIGH PRESSURE SWITCH
IF	INDOOR FAN MOTOR
ICB	INDOOR CONTROL BOARD
LP	LOW PRESSURE SWITCH
LSC	LOW SPEED CAPACITOR
MSC	MEDIUM SPEED CAPACITOR
OF	OUTDOOR FAN MOTOR
OCB	OUTDOOR CONTROL BOARD
OFRC	OUTDOOR FAN RUN CAPACITOR
RV	REVERSING VALVE
TX	ZONE TRANSFORMER 240/24V AC
TWC	TOUCH WALL CONTROLLER
WC	WALL CONTROLLER

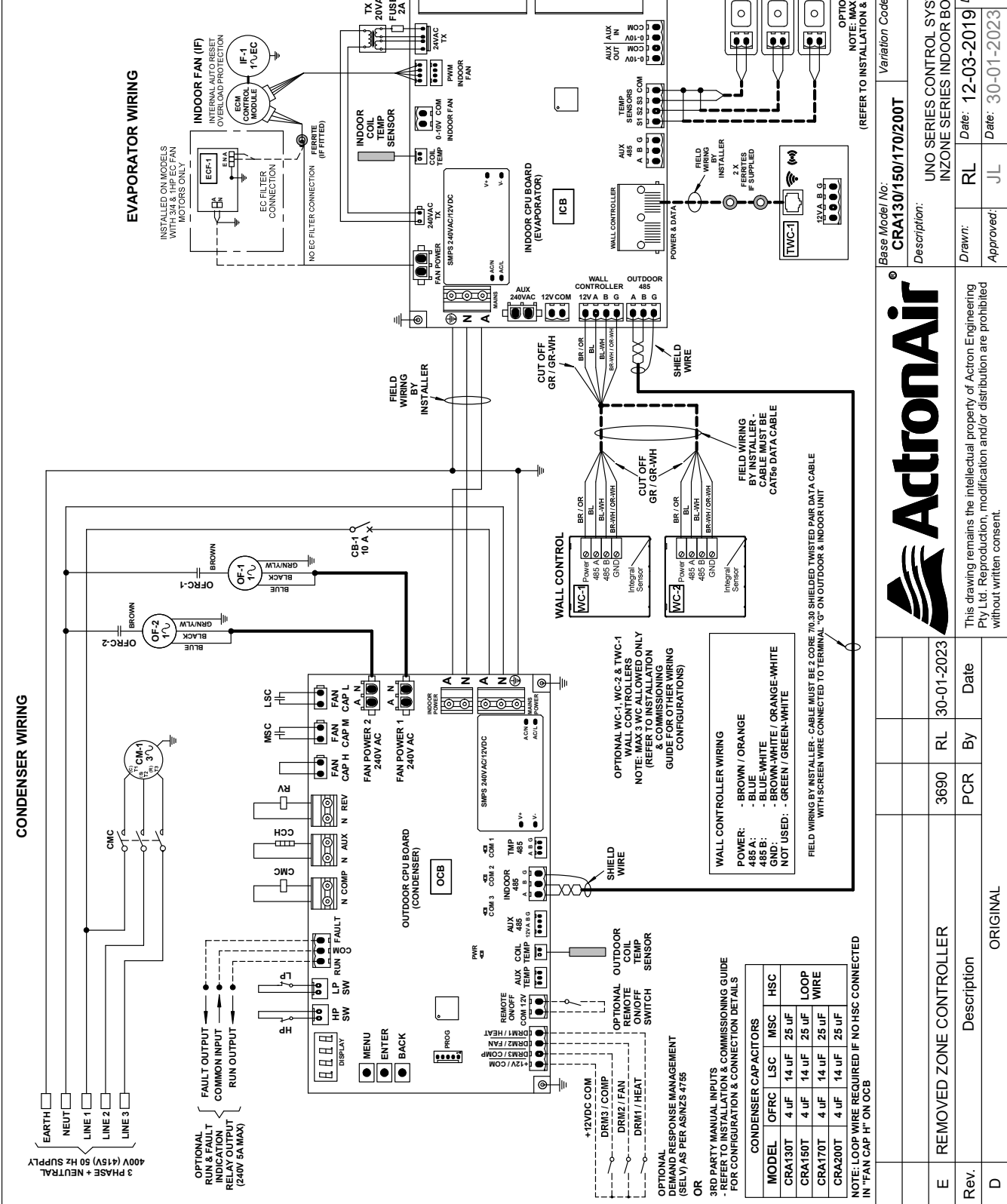

Base Model No: **CRA130/150/170/200T**

Description: **UNO SERIES CONTROL SYSTEM WIRING DIAGRAM WITH INZONE SERIES INDOOR BOARD & WALL CONTROL**

Variation Code: **STANDARD**

Drawn: **RL** Date: **12-03-2019** Drawing No: **WD2202**

Approved: **JL** Date: **30-01-2023**

Revision: **E** Size: **A4**

		This drawing remains the intellectual property of Actron Engineering Pty Ltd. Reproduction, modification and/or distribution are prohibited without written consent.	
		Rev.	Description
E	REMOVED ZONE CONTROLLER	3690	RL 30-01-2023
D	ORIGINAL	PCR	By Date

H OUTDOOR UNIT - HORIZONTAL DISCHARGE FANS

OVERALL NOMINAL DIMENSION (H x W x L)
= 1015 x 1460 x 610
USE M12 BOLT FOR FEET MOUNTING

NOTES:

1. All dimensions are in mm unless specified.
2. Do not scale drawing.
3. Additional Full Coil Coat Protection option available on all units.
4. Suggested Service Clearance and Airflow Allowances are based on conditions that the spaces are free from obstructions and walkway passage of 1000 mm is available.
5. Minimum service access areas are responsibilities of the installer.
6. Maximum External Static of Outdoor Fans is 5 Pa.
7. Multiple drainage is as illustrated on the standard outdoor model.

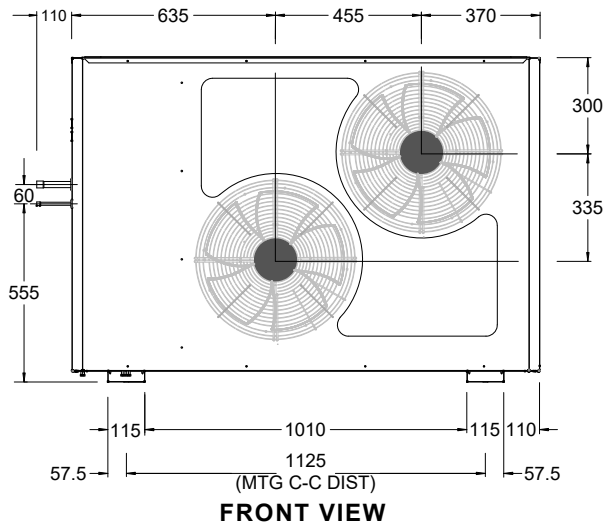
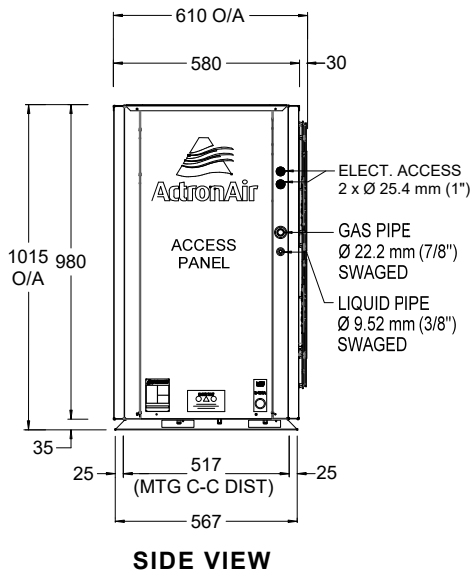
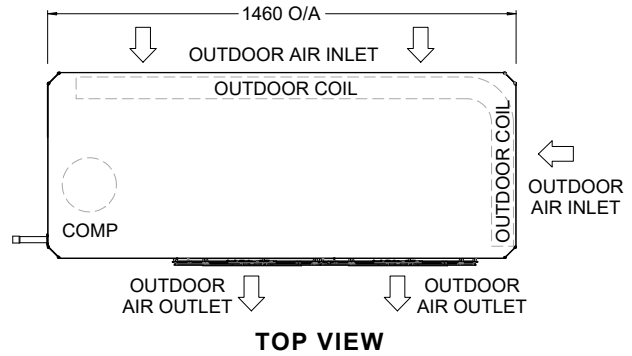
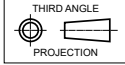

3 Phase
1 Stage
19.69 kW

MINIMUM SERVICE ACCESS AREAS AND AIRFLOW CLEARANCES

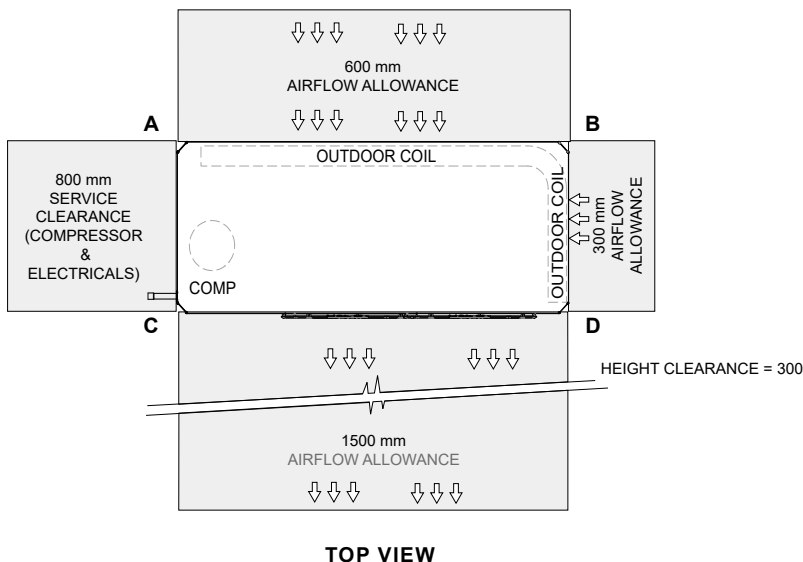

PLEASE NOTE THAT UNDER ALL CIRCUMSTANCES, CONDENSER AIR MUST NOT RECIRCULATE BACK ONTO CONDENSER COIL. KEEP ALL CLEARANCES FREE OF ANY OBSTRUCTIONS

STACKING OF UNITS	
ONE IN FRONT OF THE OTHER (DISTANCE BET. A & B)	SIDE BY SIDE (DISTANCE BET. A & C)
1000 mm	1500 mm



V INDOOR UNIT - UPRIGHT FAN COIL WITH VERTICAL DISCHARGE

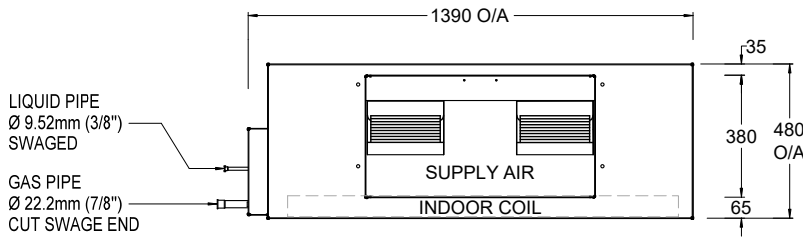

TOP VIEW

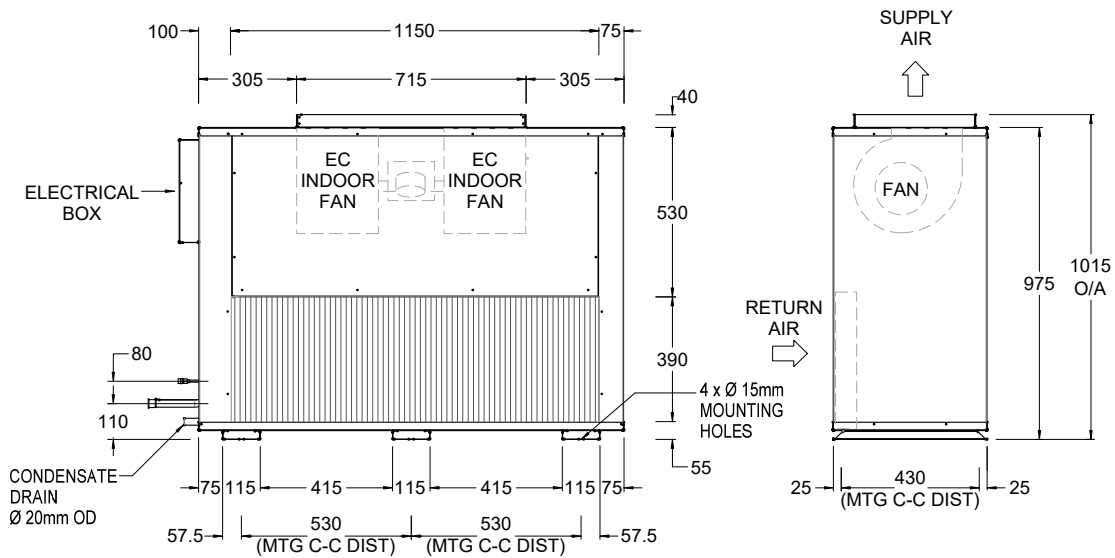

FRONT VIEW

SIDE VIEW

MINIMUM SERVICE ACCESS AREAS

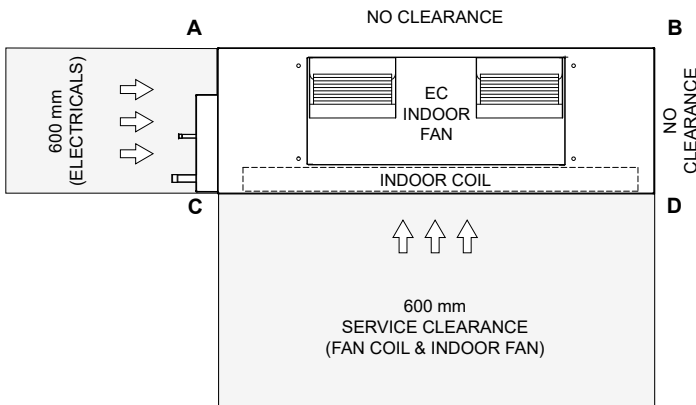

HEIGHT CLEARANCE = DUCT WORK

TOP VIEW

NOTES:

- All dimensions are in mm unless specified.
- Do not scale drawing.
- Refer Fan Curve to corresponding standard EVA200S model.
- Additional Full Coil Coat Protection option available on all units.
- Suggested Service Clearance and Airflow Allowances are based on conditions that the spaces are free from obstructions and walkway passage of 1000 mm is available.
- Minimum service access areas are responsibilities of the installer.

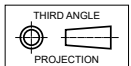

PLEASE NOTE THAT UNDER ALL CIRCUMSTANCES, CONDENSER AIR MUST NOT RECIRCULATE BACK ONTO CONDENSER COIL. KEEP ALL CLEARANCES FREE OF ANY OBSTRUCTIONS

STACKING OF UNITS	
ONE IN FRONT OF THE OTHER (DISTANCE BET. A & B)	SIDE BY SIDE (DISTANCE BET. A & C)
600 mm	1000 mm