

# SPLIT DUCTED UNIT



## UNIT FEATURES

- Compliant Scroll Compressor
- Pre-charged with R-410A Refrigerant
- Multiple Speed Outdoor Fans
- Hydrophilic Blue Fin coil Coat Protection - Indoor & Outdoor Coils
- Louvred Outdoor Coil Guard
- EC Variable Speed Indoor Fan
- Adjustable Dial-Up Indoor Airflow
- Adaptive Demand Defrost
- Integrated Condensate Safety Drain Tray

## UNIT OPTIONS

- Low Ambient
- Compressor Soft Starters
- Phase Protection
- Additional Full Coil Coat Protection
- Fault Detection Board

## CONTROL OPTIONS

### ActronAir C7-4 (BCA Compliant)

- 7-Day Programmable Controller with 2 Events/Day
- Temperature Set Back and After Hours Timer
- Zone Kit for Control up to 4 Zones (See Control Section)
- Auto, Heat & Cool Modes
- Auto/Continuous Indoor Fan Operation
- 1 Speed Indoor Fan Setting
- Hot Start Feature
- 2 Stage Cooling/Heating with 3rd Stage Boost Heat
- Manual Control Inputs
- Remote Temperature Sensors
- 24-Hour ON/OFF Timer
- Home/Building Automation ON/OFF Capability

## UNIT COMPLIANCE

- MEPS 2012 / GEMS 2012
- AS/NZS 4755.3.1 Demand Response Capabilities
- AS/NZS 60335.1 Electrical Appliance Safety
- AS/NZS CISPR 11:2011 (Group 1 ClassA) EMC Compliance

## SPECIFICATION SUMMARY

OUTDOOR UNIT MODEL	SCA330C	
INDOOR UNIT MODEL	SCG330E	
	<sup>(1)</sup> TOTAL	<sup>(2)</sup> NETT
<sup>(3)</sup> COOLING CAPACITY (kW)	32.90	32.00
<sup>(3)</sup> SENSIBLE CAPACITY (kW)	27.78	26.88
<sup>(4)</sup> HEATING CAPACITY (kW)	32.10	33.00
<sup>(5)</sup> COOLING INPUT POWER (kW)	9.55	
<sup>(5)</sup> HEATING INPUT POWER (kW)	9.25	
EER	3.45	3.35
COP	3.47	3.57
<sup>(6)</sup> INDOOR AIRFLOW (l/s) - MIN. / NOMINAL / MAX.	1450 / 1770 / 1900	
<sup>(7)</sup> OUTDOOR SOUND PRESS. LEVEL @ 3M dB(A) - LOW / HIGH	57.8 / 61.8	
OUTDOOR SOUND POWER LEVEL dB(A) -- LOW / HIGH	74.8 / 78.8	
POWER SUPPLY - OUTDOOR	400V / 3Ph+N / 50Hz	
POWER SUPPLY - INDOOR	230V / 1 Ph+N / 50 Hz	
<sup>(2)</sup> RATED LOAD AMPS	20.7	
<sup>(8)</sup> FULL LOAD AMPS - OUTDOOR / INDOOR / TOTAL	22.6 / 11.6 / 34.2	
<sup>(9)</sup> CIRCUIT BREAKER AND CABLE AMPS	40.0	
APPROXIMATE STARTING AMPS	118.0	
WEIGHT (kg) -- INDOOR / OUTDOOR	125 / 305	

<sup>(1)</sup> Based on unit rating excluding indoor fan kW.

<sup>(2)</sup> Measured and tested in accordance with AS/NZS 3823.1.2.

<sup>(3)</sup> At 27°C DB / 19°C WB entering air temperatures and 35°C ambient.

<sup>(4)</sup> At 20°C DB entering air temperature and 7°C DB / 6°C WB ambient.

<sup>(5)</sup> Input power includes indoor fan kW.

<sup>(6)</sup> Max. - Min. airflow application range.

<sup>(7)</sup> Outdoor sound pressure level is determined in an anechoic chamber and may differ once the unit is installed due to environment conditions.

<sup>(8)</sup> Full Load Amps are based on compressor and fan motors' maximum expected current.

<sup>(9)</sup> See Specifications sheet for cable size and circuit breaker size details.

Note: Use input power to estimate running cost.

3 Phase  
1 Stage

32.90 kW





# OUTDOOR UNIT DIMENSIONS

# SCA330C / SCG330E

## OUTDOOR UNIT SCA330C

OVERALL NOMINAL DIMENSION (H x W x D)  
= 1330 x 1875 x 875  
USE M12 BOLT FOR FEET MOUNTING

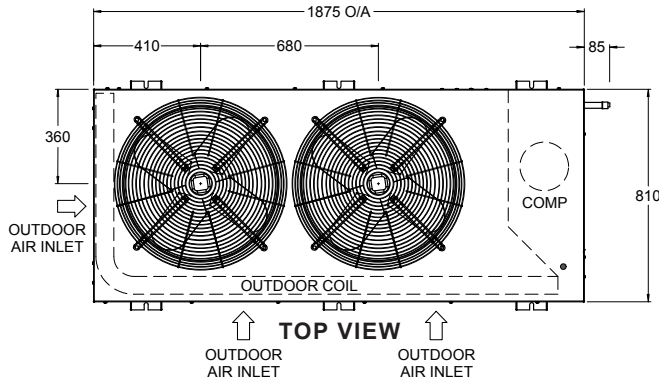

CONDENSATION POINTS ARE DESIGNED TO ENSURE ALL CONDENSATION IS REMOVED EFFICIENTLY TO AVOID WATER POOLING WITHIN THE CONDENSER. IF A SINGLE CONDENSATION DRAIN POINT IS REQUIRED, ACTRONAIR RECOMMENDS THE INSTALLATION OF A CONDENSER TRAY.

\*\* DRAWING IS SUBJECT TO CHANGE WITHOUT NOTICE\*\*

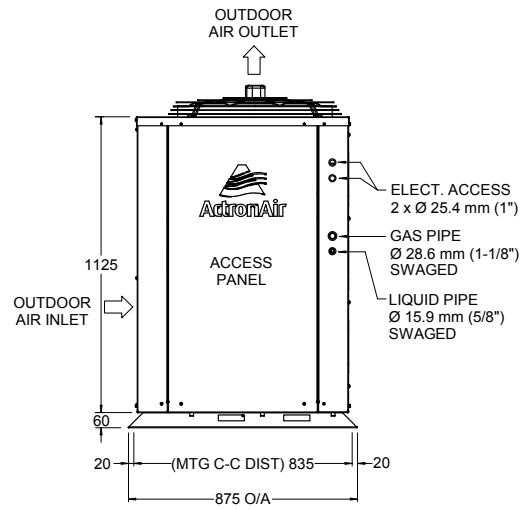
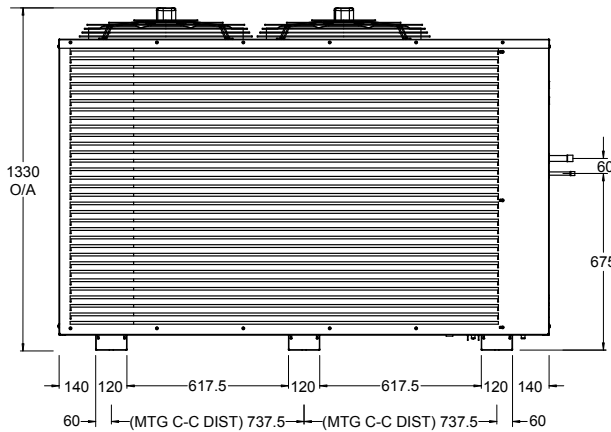

UNIT MODEL NUMBER	UNIT WEIGHT (kg)	CORNER WEIGHTS (kg)					
		A	B	C	D	E	F
SCA330C	305	25.4	24.3	100.5	37.0	17.3	100.5

3 Phase  
1 Stage  
32.90 kW

## MINIMUM SERVICE ACCESS AREAS AND AIRFLOW CLEARANCES

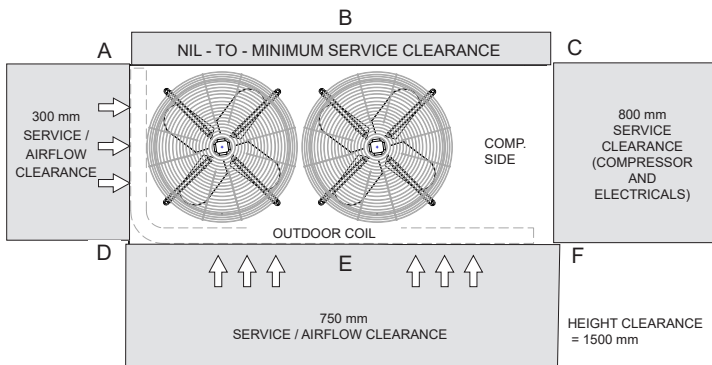

### NOTES:

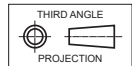

- Do not scale drawing. All dimensions are in mm unless specified. Refer to corresponding unit dimensional drawing for mounting hole details.
- Ensure that Service Access Areas and Spaces for Airflow Clearances are met. This is based on the condition that the spaces around the units are free from any obstructions and a walkway passage of 1000mm between the units or between the unit and the outside perimeter is available.
- Minimum service access areas and spaces for airflow clearances are responsibilities of the installer, ActronAir will not be held liable for any extra charges incurred due to lack of access and space for airflow.
- Under all circumstances, condenser air must not recirculate back onto condenser coil. Keep all clearance free of any obstructions.
- MTG C-C DIST = Mounting Centre to Centre Distance.
- Use M12 bolt for feet mounting.



# INDOOR UNIT DIMENSIONS

# SCA330C / SCG330E

## INDOOR UNIT SCG330E

OVERALL NOMINAL DIMENSION (H x W x D)  
 = 620 x 1735 x 770  
 SUPPLY DUCT (H x W) = 370 x 1065  
 RETURN DUCT = 520 x 1440  
 DRAIN CONNECTION = 25mm ID

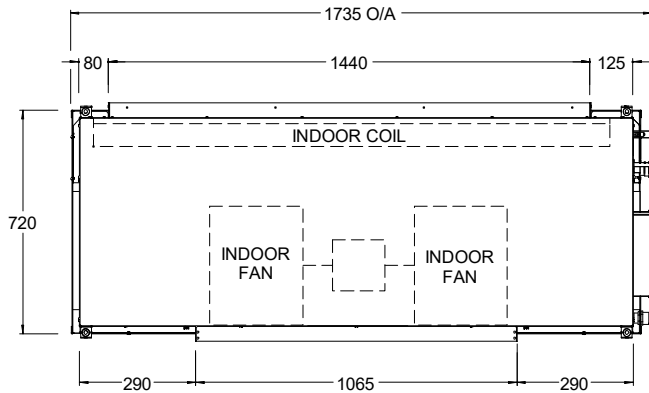

GAS PIPE  
 Ø 28.6 mm (1-1/8")  
 SWAGED

LIQUID PIPE  
 Ø 15.9 mm (5/8")  
 SWAGED

TOP VIEW

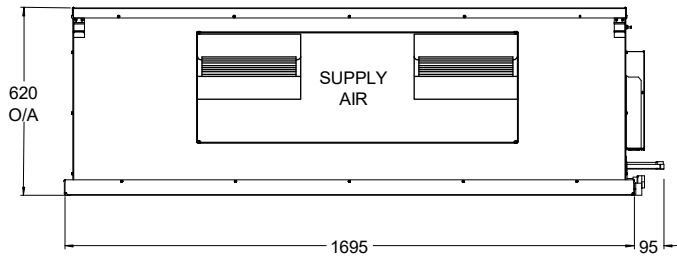

FRONT VIEW

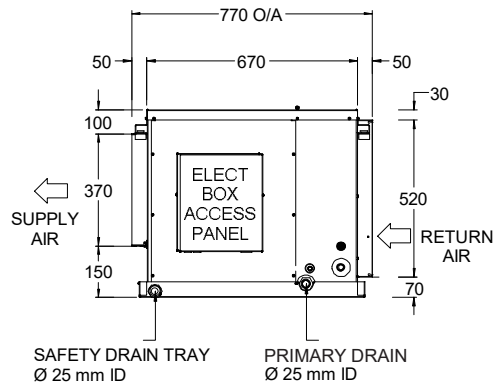

SIDE VIEW

32.90 kW  
 3 Phase 1 Stage

UNIT MODEL NUMBER	UNIT WEIGHT (kg)
SCG330E	125

## MINIMUM SERVICE ACCESS AREAS AND AIRFLOW CLEARANCES

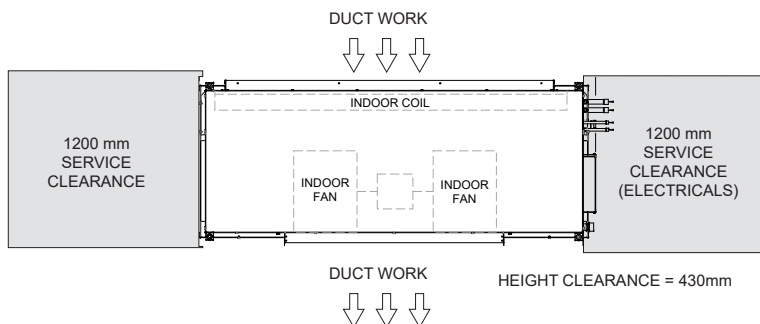

### NOTES:

- Do not scale drawing. All dimensions are in mm unless specified. Refer to corresponding unit dimensional drawing for mounting hole details.
- Service Access Areas and Spaces for Airflow Clearances are met. This is based on the condition that the spaces around the units are free from any obstructions and a walkway passage of 1000mm between the units or between the unit and the outside perimeter is available.
- Minimum Service Access Areas and Spaces for Airflow Clearances are responsibilities of the installer, ActronAir will not be held liable for any extra charges incurred due to lack of access and space for airflow.

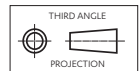

# INDOOR FAN CURVE

# SCA330C / SCG330E

AIRFLOW (l/s)	EXTERNAL STATIC PRESSURE (Pa)													
	50		100		150		200		250		300		350	
	% PWM	W	% PWM	W	% PWM	W	% PWM	W	% PWM	W	% PWM	W	% PWM	W
1450	<b>MOTOR / BLOWER LIMIT</b>		50	626	55	767	59	892	64	1042	73	1192	90	1350
1500	<b>MOTOR / BLOWER LIMIT</b>		53	680	57	797	62	953	67	1096	77	1253	94	1416
1550	51	597	56	734	60	853	65	1012	70	1172	81	1316	<b>MOTOR / BLOWER LIMIT</b>	
1600	54	647	58	761	63	912	68	1076	73	1217	86	1387		
1650	57	700	61	816	66	969	71	1138	75	1278	90	1453		
1700	60	750	65	898	69	1029	74	1198	79	1348	95	1531		
1750	63	804	68	958	72	1089	77	1261	83	1419	<b>MOTOR / BLOWER LIMIT</b>			
1770	64	820	69	974	74	1127	78	1279	85	1452				
1800	66	858	71	1015	75	1146	80	1324	88	1503				
1850	69	913	74	1072	79	1244	84	1410	93	1585				
1900	72	969	77	1131	82	1304	88	1494	<b>MOTOR / BLOWER LIMIT</b>					

**NOTES:**

W = Indoor Fan Power, Watts

PWM = Pulse Width Modulation Setting, % PWM

(Adjustable through CPI3-1 Board located in electrical panel).

Factory PWM Setting = 69 % PWM for 100 Pa.

   - Data in the box indicates Factory Default Setting.

**(CPI3-1) COMMERCIAL PWM INTERFACE BOARD**

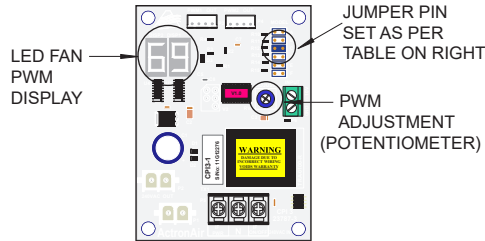

JUMPER PIN POSITION	INDOOR FAN
A	SCG400E PCG400U/L/R
B	SCG340E PCG340U/L/R
C	SCG330E PCG330U/L/R
D	PCG300L/R
E	SCG290E PCG290U/L/R
F	SCG260E PCG260U/V

- NOTES:
- LED will show PWM without %.
  - Example: 69% PWM = 69 in LED.
  - LED adjustments are in 1 digit increment.

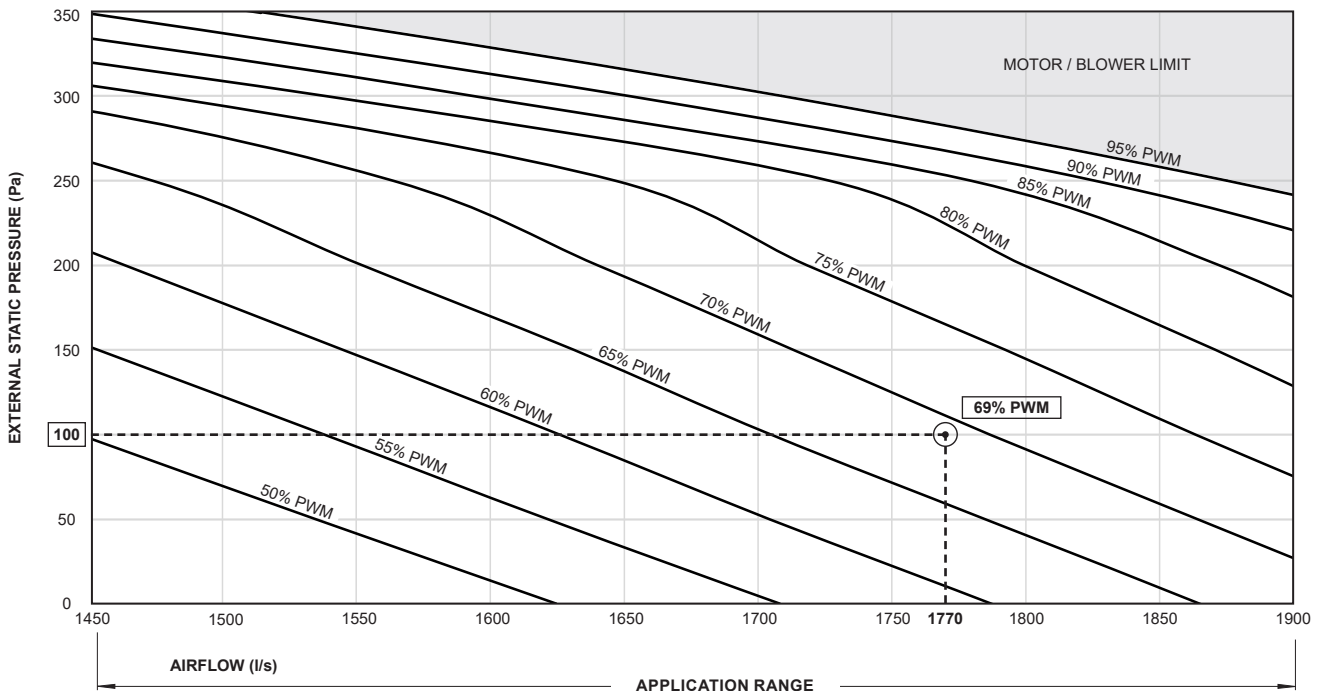

Nominal Airflow = 1770 l/s  
2.5 Face Velocity will occur at 2156l/s.



3 Phase  
1 Stage  
32.90 kW

**Outdoor Radiated**

**Sound Power Level (SWL)**

Fan Speed	Sound Power Level dB(A)	Octave Band Centre Frequency (Hz), dB						
		125	250	500	1k	2k	4k	8k
Low	74.8	76.6	76.4	71.7	69.5	65.8	61.2	55.8
High	78.8	79.7	79.3	76.7	73.6	68.9	66.7	60.9

**Indoor Outlet**

**Sound Power Level (SWL)**

Airflow Setting	Airflow Li/s	Sound Power Level dB(A)	Octave Band Centre Frequency (Hz), dB						
			125	250	500	1k	2k	4k	8k
Nominal	1720	81.0	78.3	79.5	78.4	76.4	72.6	68.9	63.9

**OUTDOOR RADIATED**

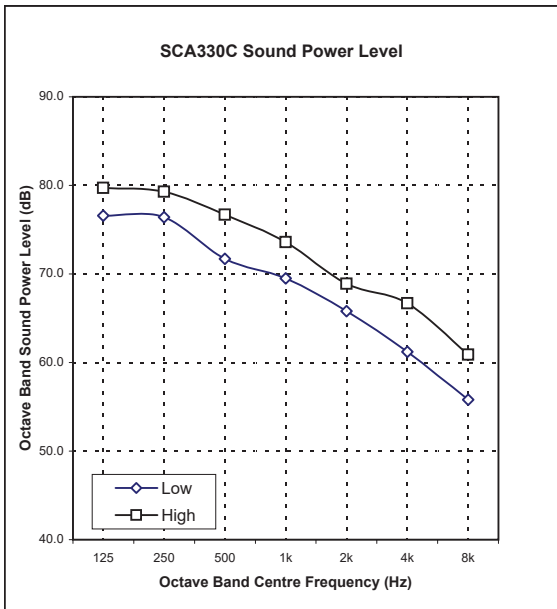

**INDOOR OUTLET**

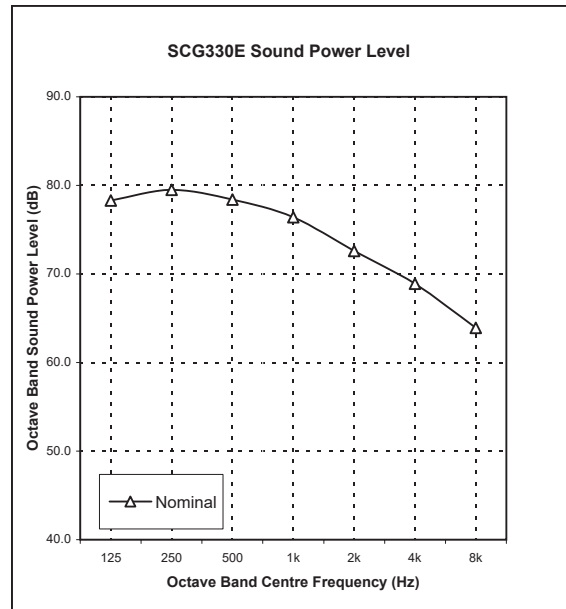

**NOTE:**

Radiated sound power levels are based on ISO 3743-1.

**32.90 kW**  
**3 Phase 1 Stage**



# SPECIFICATIONS

# SCA330C / SCG330E

## CONSTRUCTION

CABINET (Indoor Unit)	0.5 - 1.2 mm Galvanized Steel
CABINET (Outdoor Unit)	0.9 - 1.6 mm Galvanized Steel
SURFACE FINISH (Outdoor Unit)	65 $\mu$ Baked Polyester Powder Coat

## INSULATION (Indoor Unit)

TYPE	Foil Faced Polyethylene Expanded Polystyrene
------	---

## ELECTRICAL

### OUTDOOR UNIT

Power Supply - 50 Hz	400 Volts x 3 Phase + N
Voltage Range (min - max)	380 V - 440 V
Full Load Amps*	22.6
Approximate Starting Amps	118.0
IP Rating	IP44

### INDOOR UNIT

Power Supply - 50 Hz	230 Volts x 1 Phase + N
Voltage Range (min - max)	216 V - 253 V
Full Load Amps*	11.6
IP Rating	IP20

### OUTDOOR & INDOOR UNIT (TOTAL)

Full Load Amps* - Phase 1	34.2
Full Load Amps* - Phase 2 and 3	19.5 and 20.5
Rated Load Amps**	20.7

IMPORTANT - The local electricity authority may require limits on starting current and voltage drop, please check prior to purchase.

\* Full Load Amps are based on Compressor and Fan Motor's maximum expected current.

\*\* Rated Load Amps are measured and tested in accordance with AS/NZS3823.1.2.

## CABLE SIZE & CIRCUIT BREAKER SIZE

- Cable size recommendation selected in accordance to maximum conductor temperature of 75°C with wiring enclosed in air.
- Suggested minimum cable size should be used as a guide only, refer to AS/NZS 3000 "Australian/New Zealand Wiring Rules" for more details.

Cable Size (main line)	10.0 mm <sup>2</sup> (SUGGESTED MINIMUM)
Cable Size (indoor to outdoor wire)	1.5 mm <sup>2</sup> (SUGGESTED MINIMUM)
Circuit Breaker Size	40.0 Amps

## OUTDOOR COIL

TUBE TYPE	Copper - Rifle Bore
FIN TYPE	Aluminium - Wave
FACE AREA (m <sup>2</sup> sq)	2.50
FIN SPACING (per m)	472
COIL COATING	Hydrophilic Blue Fin Coil Coat Protection

## OUTDOOR FAN

NUMBER OF FANS x TYPE	2 x Axial
NUMBER OF BLADES PER FAN	4
DIAMETER (mm)	560
OUTPUT kW	0.37
MOTOR TYPE / DRIVE TYPE	6 Pole External Rotor / Direct
FAN SPEED CONTROL	2 Speed via Capacitor

The standard type outdoor fans fitted to this unit will accept up to 5Pa of external static resistance.

## INDOOR COIL

TUBE TYPE	Copper - Rifle Bore
FIN TYPE	Aluminium - Louvre
FACE ARE (m <sup>2</sup> sq)	0.86
FIN SPACING (per m)	472
COIL COATING	Hydrophilic Blue Fin Coil Coat Protection

## INDOOR FAN

NUMBER OF FANS x TYPE	1 x Twin Deck Centrifugal EC Fan
DIAMETER / WIDTH (mm)	270 x 270
OUTPUT kW / INPUT kW	1.12 / 0.90
MOTOR TYPE / DRIVE TYPE	Variable Speed EC Motor / Direct

## AIR FILTERS

All return air including fresh air must have adequate filters supplied and fitted by the installing contractor. Filters must be located in accessible location between the return air grille and the unit.  
ActronAir does not supply or make any provisions for return air filter.

## COMPRESSOR

NUMBER PER UNIT x TYPE	1 x Scroll (Hermetic)
FULL LOAD AMPS	20.0
LOCKED ROTOR AMPS	118.0
STARTING METHOD	D.O.L. (optional soft starter)

## REFRIGERATION SYSTEM

REFRIGERANT TYPE	R-410A
EXPANSION CONTROL	Direct Expansion Orifice
FACTORY CHARGE (grams)	12,800
PRE-CHARGE LENGTH (metres)	5
ADDITIONAL REF. CHARGE (gm/m)	165

## FILTER DRIER

CONNECTION SIZE AND TYPE	15.9 mm (5/8") ODF Soldered Bi-Flow
FACTORY SUPPLIED / FITTED	Yes
See Installation Section for complete Filter Drier specifications.	

## INTERCONNECTING PIPE RUN

MAX PIPE LENGTH (metres)	60
MAX. VERTICAL LENGTH (metres)	20 (Included in Max. Pipe Length)
FIELD PIPE SIZES	
Liquid Pipe	15.9 mm (5/8")
Gas Pipe	28.6 mm (1-1/8")

## PIPE CONNECTIONS

Indoor	Liquid Pipe	15.9 mm (5/8") Swaged to fit 15.9 mm (5/8") field pipe
	Gas Pipe	28.6 mm (1-1/8") Swaged to fit 28.6 mm (1-1/8") field pipe
Outdoor	Liquid Pipe	15.9 mm (5/8") Swaged to fit 15.9 mm (5/8") field pipe
	Gas Pipe	28.6 mm (1-1/8") Swaged to fit 28.6 mm (1-1/8") field pipe

CONNECTION TYPE	Solder
Insulate both gas and liquid pipes separately.	

## PROTECTION DEVICES

HIGH PRESSURE CUTOFF SWITCH	Nonadjustable (Automatic Reset)
LOW PRESSURE CUTOFF SWITCH	Nonadjustable (Automatic Reset)
COMPRESSOR MOTOR TEMP.	Internal Thermal Cut-Out
INDOOR FAN OVERLOAD	Internal Thermal Cut-Out
OUTDOOR FAN OVERLOAD	Internal Thermal Cut-Out
SUMP HEATER WATTS	50 W during Comp. Off Cycle

## ELECTRIC CONTROLS

DEFROST METHOD	Reverse Cycle
DEFROST TYPE	Adaptive Demand Defrost
CONTROL CIRCUIT BREAKER	16.0 Amps
CONTROL FIELD WIRING	2 Core 14 / 0.20 Screened Cable

## OPERATING RANGE

It is essential that the unit is correctly sized for the application and operates within its recommended range of operating conditions as shown below.

MODE	RANGE	INDOOR AIR INTAKE TEMPERATURE	OUTDOOR AIR INTAKE TEMPERATURE
		Max.	30°C DB / 22°C WB
Cooling	Min.	20°C DB / 16°C WB	15°C DB
	Max.	24°C DB	19.5°C DB / 18°C WB
Heating	Min.	16°C DB	-10°C WB

IMPORTANT - For low ambient cooling use option S. Lower ambient available on request. Contact your nearest ActronAir office for more details.

Low Ambient Cooling	Option S	Max.	29°C DB / 19°C WB	50°C DB
		Min.	20°C DB / 15°C WB	5°C DB
	On Request	Max.	29°C DB / 19°C WB	50°C DB
		Min.	20°C DB / 15°C WB	-5°C DB

3 Phase  
1 Stage

32.90 kW



# WIRING DIAGRAM

# SCA330C / SCG330E

**32.90 kW**  
**3 Phase 1 Stage**

### LEGEND

CB	CIRCUIT BREAKER
CCH	CRANKCASE HEATER
CM	COMPRESSOR MOTOR
CMC	COMPRESSOR MOTOR CONTACTOR
CPI	INDOOR FAN VARIABLE SPEED BOARD
ECM	EC FILTER
HCT	HIGH SPEED FAN CONTACTOR
HP	HIGH PRESSURE SWITCH
IF	INDOOR FAN MOTOR
LCT	LOW SPEED FAN CONTACTOR
LP	LOW PRESSURE SWITCH
LSC	LOW SPEED CAPACITOR
OF	OUTDOOR FAN MOTOR
OCB	OUTDOOR CONTROL BOARD
PFC	POWER FACTOR CORRECTION CAPACITORS
PFCC	POWER FACTOR CORRECTION CONTACTOR
RV	REVERSING VALVE
TERM	MAIN TERMINAL BLOCKS
WC	WALL CONTROLLER

### DEFAULT FAN SPEED SETTINGS (@100pa)

SCA230C	61% PWM
SCA330C	69% PWM

### FINAL COMMISSIONING FAN SETPOINT

PWM: ..... % PWM

Date: .....

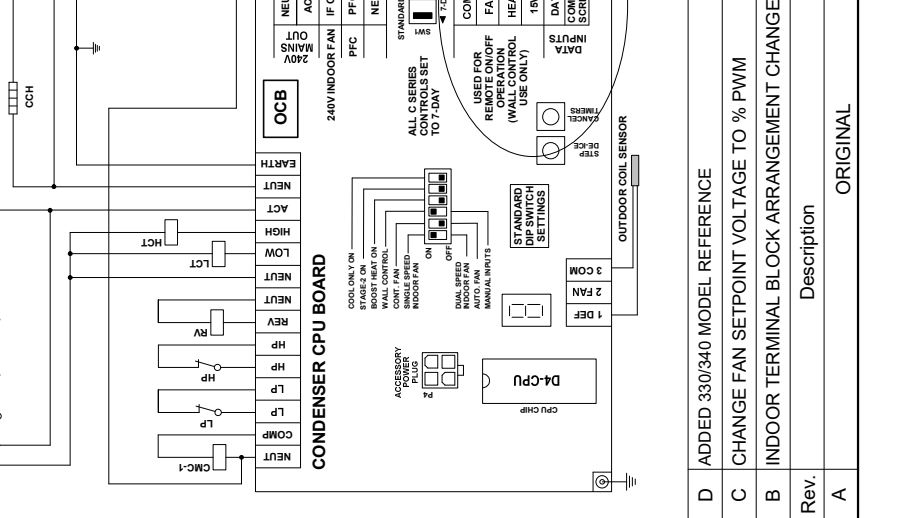
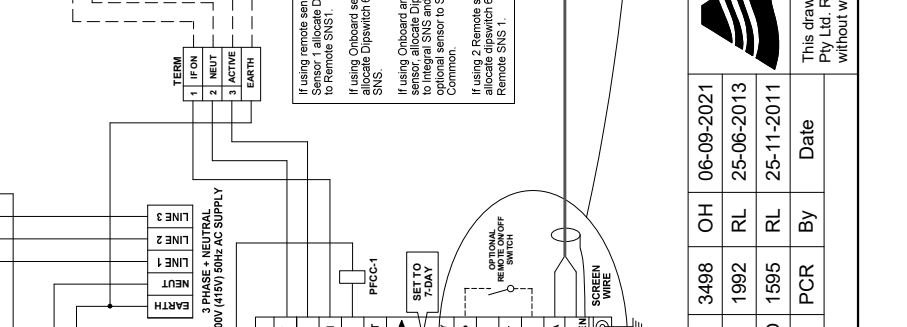
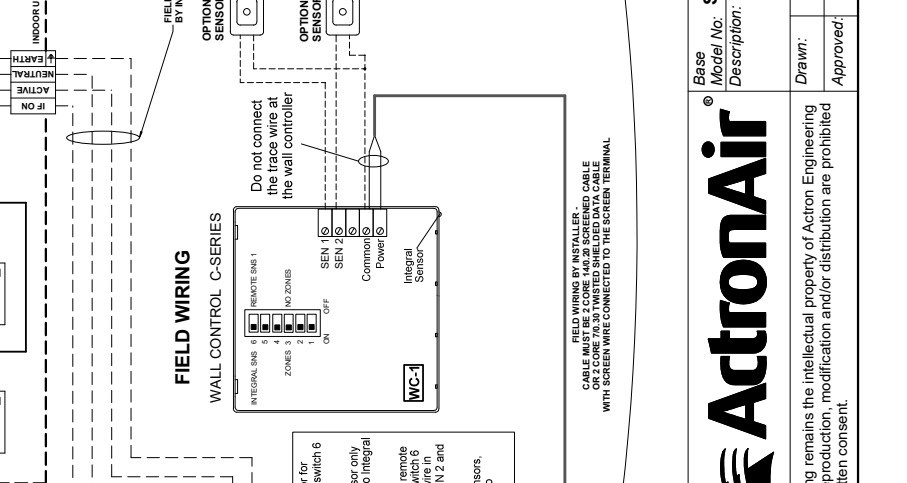
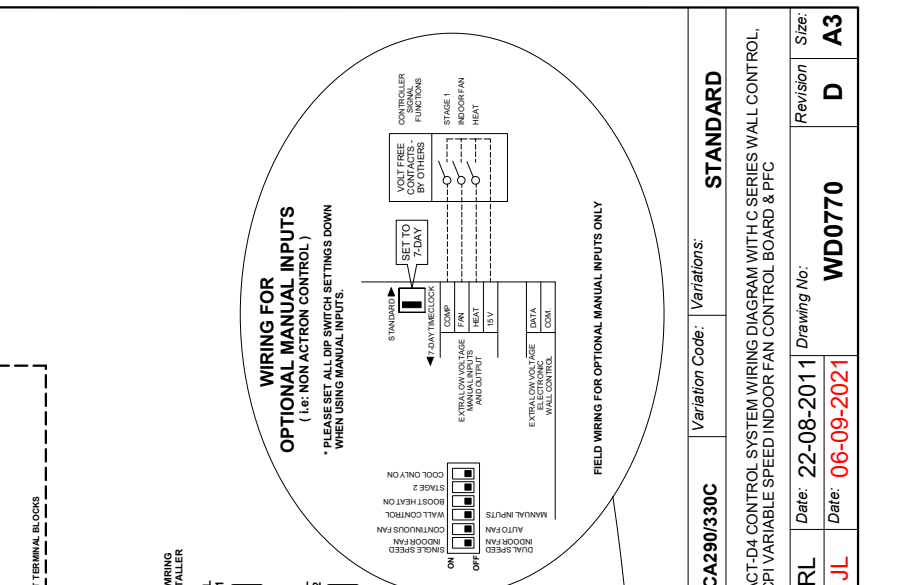
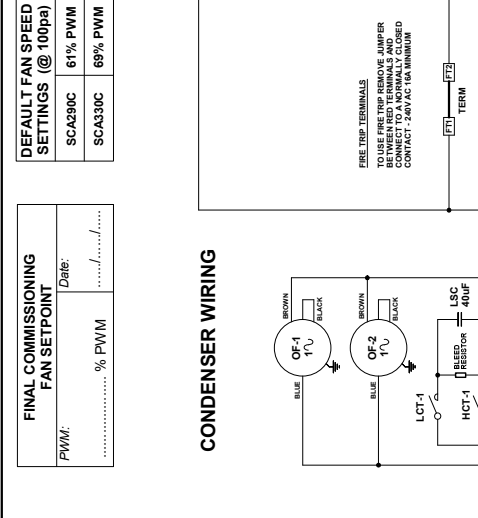
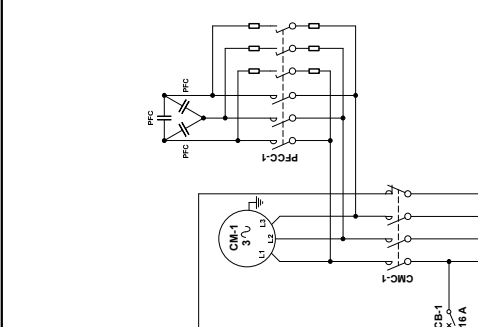
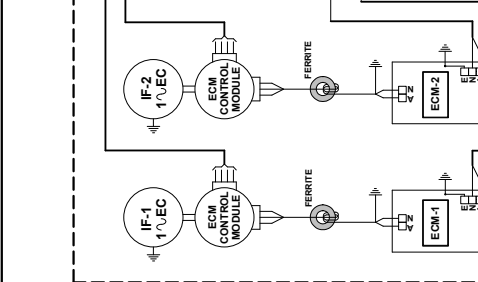

D	ADDED 330/340 MODEL REFERENCE	3498	OH	06-09-2021	By	Date	3	Model No:	SCA290/330C	Variation Code:	STANDARD
C	CHANGE FAN SETPOINT VOLTAGE TO % PWM	1992	RL	25-06-2013	By	Date	2	Description:	ACT-D4 CONTROL SYSTEM WIRING DIAGRAM WITH C SERIES WALL CONTROL, CPI VARIABLE SPEED INDOOR FAN CONTROL BOARD & PFC		
B	INDOOR TERMINAL BLOCK ARRANGEMENT CHANGED	1595	RL	25-11-2011	By	Date	1	Drawn:	RL	Date:	22-08-2011
Rev.	Description	PCR	By	Date	Approved:	Date:	06-09-2021	Drawing No:	WD0770	Revision	D
A	ORIGINAL							Size:	A3		



This drawing remains the intellectual property of Actron Engineering Pty Ltd. Reproduction, modification and/or distribution are prohibited without written consent.



## H OUTDOOR UNIT - HORIZONTAL DISCHARGE FANS 5 Pa

OVERALL NOMINAL DIMENSION (H x W x D)  
= 1185 x 1875 x 980  
USE M12 BOLT FOR FEET MOUNTING

CONDENSATION POINTS ARE DESIGNED TO ENSURE ALL CONDENSATION IS REMOVED EFFICIENTLY TO AVOID WATER POOLING WITHIN THE CONDENSER. IF A SINGLE CONDENSATION DRAIN POINT IS REQUIRED, ACTRONAIR RECOMMENDS THE INSTALLATION OF A CONDENSER TRAY. THESE ARE AVAILABLE AS AN ADDITIONAL ACCESSORY.

\*\* DRAWING IS SUBJECT TO CHANGE WITHOUT NOTICE\*\*

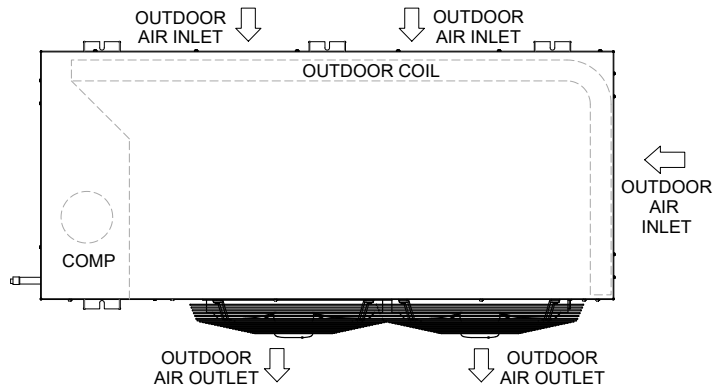

TOP VIEW

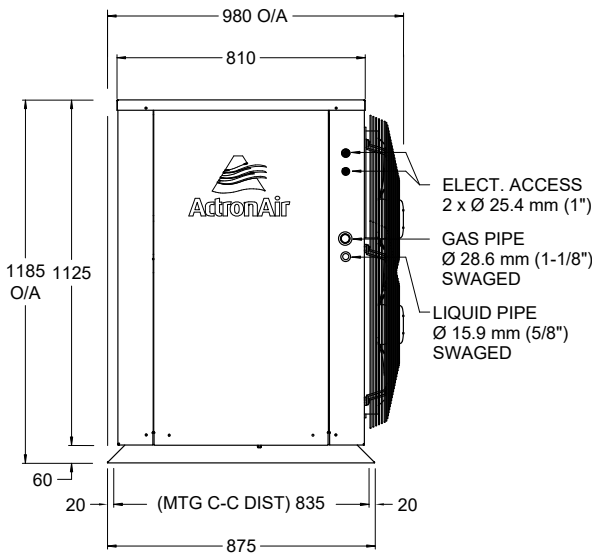

SIDE VIEW

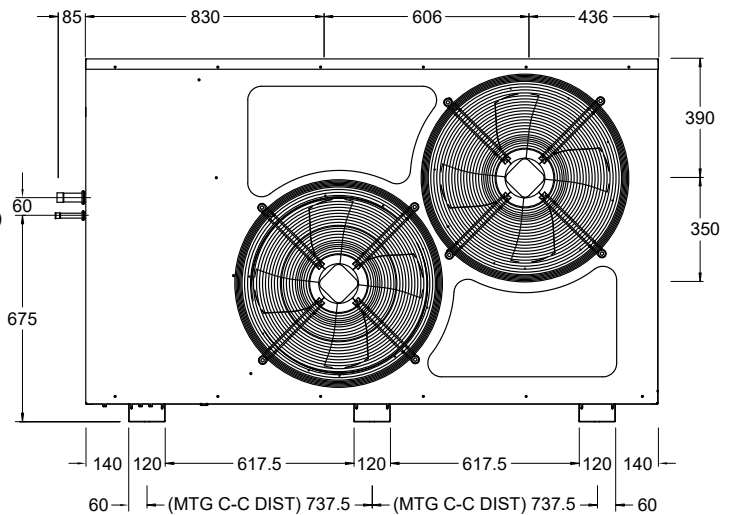

FRONT VIEW

3 Phase  
1 Stage  
32.90 kW

### MINIMUM SERVICE ACCESS AREAS AND AIRFLOW CLEARANCES

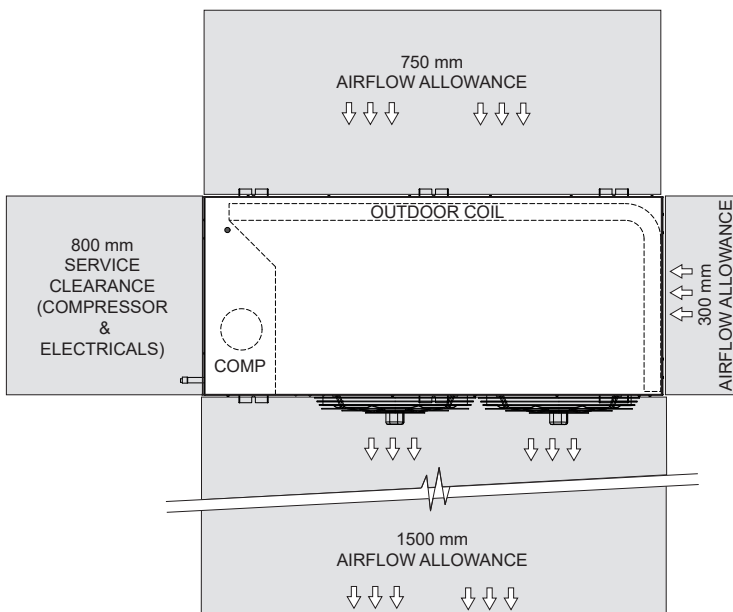

TOP VIEW

HEIGHT CLEARANCE = 600

#### NOTES:

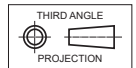

1. Do not scale drawing. All dimensions are in mm unless specified. Refer to corresponding unit dimensional drawing for mounting hole details.
2. Ensure that Service Access Areas and Spaces for Airflow Clearances are met. This is based on the condition that the spaces around the units are free from any obstructions and a walkway passage of 1000mm between the units or between the unit and the outside perimeter is available.
3. Minimum service access areas and spaces for airflow clearances are responsibilities of the installer. ActronAir will not be held liable for any extra charges incurred due to lack of access and space for airflow.
4. Under all circumstances, condenser air must not recirculate back onto condenser coil. Keep all clearance free of any obstructions.
5. MTG C-C DIST = Mounting Centre to Centre Distance.
6. Use M12 bolt for feet mounting.

## V INDOOR UNIT - UPRIGHT FAN COIL WITH VERTICAL DISCHARGE

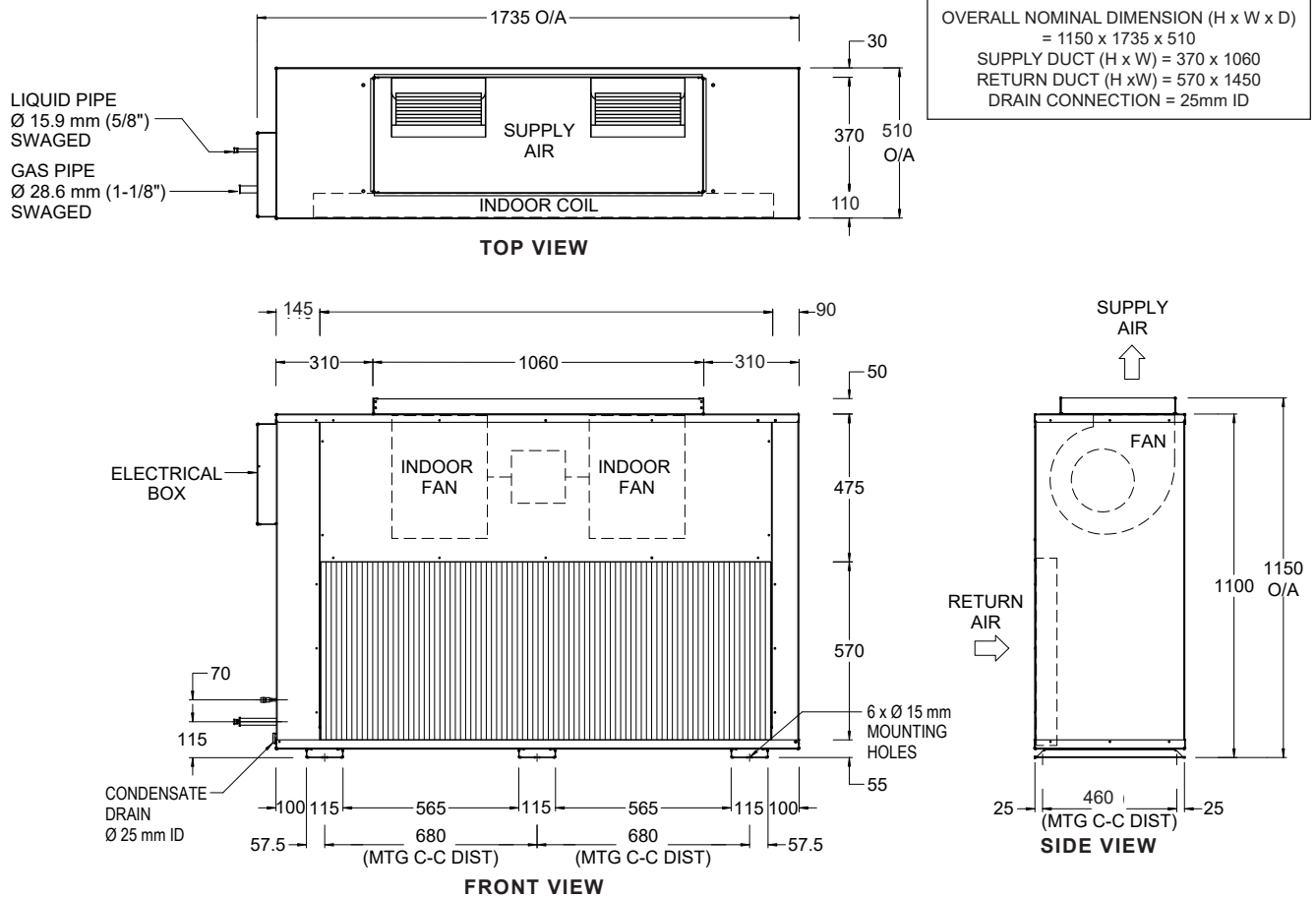

32.90 kW  
3 Phase 1 Stage

### MINIMUM SERVICE ACCESS AREAS AND AIRFLOW CLEARANCES

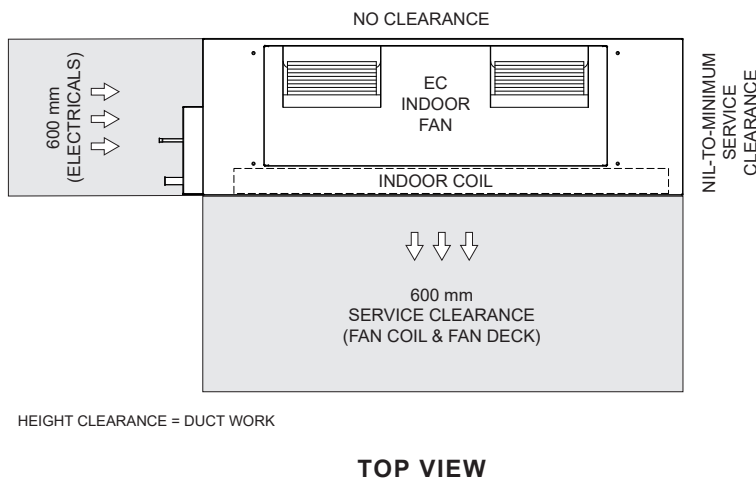

### NOTES:

- Do not scale drawing. All dimensions are in mm unless specified. Refer to corresponding unit dimensional drawing for mounting hole details.
- Ensure that Service Access Areas and Spaces for Airflow Clearances are met. This is based on the condition that the spaces around the units are free from any obstructions and a walkway passage of 1000mm between the units or between the unit and the outside perimeter is available.
- Minimum service access areas and spaces for airflow clearances are responsibilities of the installer, ActronAir will not be held liable for any extra charges incurred due to lack of access and space for airflow.
- Under all circumstances, condenser air must not recirculate back onto condenser coil. Keep all clearance free of any obstructions.
- MTG C-C DIST = Mounting Centre to Centre Distance.
- Use M12 bolt for feet mounting.

