

ADVANCE (R-32 Series) Split Ducted Unit

Technical Selection Data



1
SINGLE PHASE

3
THREE PHASE

SINGLE STAGE

ECM FAN

INVERTER

LOUVRE

SOFT START

ECM AXIAL FAN

R-32
REFRIGERANT

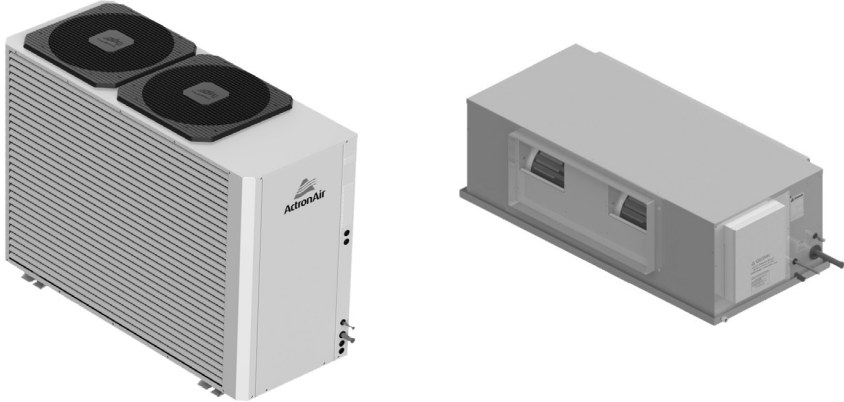

Model Numbers

Single Phase	Three Phase	Split Fan-Coil
CRV13AS / EVV13AS	CRV13AT / EVV13AS	EAA13AS / EFV13AS
CRV15AS / EVV15AS	CRV15AT / EVV15AS	EAA15AS / EFV15AS
CRV17AS / EVV17AS	CRV17AT / EVV17AS	EAA17AS / EFV17AS

UNIT FEATURES

- Inverter Variable Speed Compressor and Drive Technology
- 28-100% Superior Refrigeration Operating Capacity Range
- EC High Efficiency Indoor and Outdoor Fan Motor
- Pre-charged with Low GWP R-32 Refrigerant
- Adaptive Demand Defrost
- Active Power Factor Correction
- 20m Cat5e wall controller cable included
- Low ambient cooling operation to +5 degree
- Fault and Run Indication - Relay Output
- Up to 3 Wall Controllers and 3 Remote Temperature Sensors
- Ready for up to 8 zones
- Compressor Soft Start via Variable Speed Drive Control
- Hydrophilic Blue Fin Coil Coat Protection - Indoor and Outdoor Coils
- Integrated Fan Coil Safety Tray with Drain Kit
- Bi-Flow Electronic Expansion Valve
- Powder Coated Outdoor Unit with Louvred Coil Guard
- Variable Fan Technology
- Turbo Mode

UNIT OPTIONS

- Additional Full Coil Coat Protection
- Split Fan Coil Unit
- Vertical Fan Coil Unit
- Horizontal Discharge Condenser
- Outdoor Drain Tray

UNIT COMPLIANCE

- AS/NZS 3823.2 (MEPS)
- AS/NZS 4755.3.1:2012 (DRM 1, 2 and 3)
- AS/NZS CISPR 14.1 (EMC)
- AS/NZS 60335.2.40 in conjunction with AS/NZS 60335.1 (Electrical Safety - Air Conditioner)

CONTROL OPTIONS AND FEATURES

ActronAir LR7-1/LC7-2

- Available in White or Grey
- 7-day Programmable Controller with 2 Events per Day
- 24-hour ON/OFF Timer
- Temperature Setback
- After Hours Time (LC7-2 Only)
- Auto, Heat, Cool, Turbo, Fan Modes and Night Mode Functions
- Fixed, Auto and Continuous Indoor Fan Operation
- Optional 2nd and 3rd Controllers with Mimic Logic
- On-board Temperature Sensor

ActronAir NEO

- 7" Colour Touch Screen Master Controller
- In-built Wi-Fi and Blue-Tooth
- Neo Connect App
- On-Board Temperature, Humidity and Proximity Sensor
- Optional wireless Zone Controller with on-board sensor
- Optional wireless Zone Sensor
- Available in White or Black

ActronAir Group Control

ActronAir BMS ICUNO-MOD (Modbus 485)

Third Party Control

- Optional Manual Inputs
- Optional Analogue Inputs

PLENUMS

(See Plenum Matrix for details of spigots availability).

- Supply Air Plenums are available in 2 or 3 way Configuration.
- Return Air Plenums are available with 2 x 350 mm or 2 x 400 mm or 2 x 450mm Spigots.



SPECIFICATION SUMMARY

OUTDOOR UNIT MODEL		CRV13AS		CRV15AS		CRV17AS		CRV13AT		CRV15AT		CRV17AT	
INDOOR UNIT MODEL		EVV13AS		EVV15AS		EVV17AS		EVV13AS		EVV15AS		EVV17AS	
		(1) TOTAL	(2) NETT	(1) TOTAL	(2) NETT	(1) TOTAL	(2) NETT	(1) TOTAL	(2) NETT	(1) TOTAL	(2) NETT	(1) TOTAL	(2) NETT
(3) COOLING CAPACITY (kW)	RATED	13.45	13.20	14.90	14.40	17.35	16.80	13.05	12.80	14.95	14.75	17.35	17.00
	Tru-Max ⁽¹⁰⁾	-	14.50	-	16.50	-	18.70	-	14.50	-	16.50	-	18.70
	MINIMUM	-	4.05	-	4.48	-	4.65	-	3.93	-	4.49	-	4.65
(4) HEATING CAPACITY (kW)	RATED	13.15	13.40	15.10	15.53	17.25	18.00	13.40	13.65	15.70	16.00	17.85	18.20
	Tru-Max ⁽¹⁰⁾	-	15.00	-	17.60	-	19.80	-	15.00	-	17.60	-	19.80
	MINIMUM	-	3.75	-	4.31	-	5.05	-	3.82	-	4.48	-	5.28
(3) SENSIBLE CAPACITY (kW)	RATED	11.07	10.82	12.27	11.97	14.63	14.28	10.62	10.37	12.31	12.01	14.29	13.94
(5) COOLING INPUT POWER (kW)	RATED	3.88		4.34		5.02		3.68		4.32		5.00	
(5) HEATING INPUT POWER (kW)	RATED	3.82		4.43		5.13		3.88		4.56		5.17	
EER	RATED	3.47	3.40	3.36	3.32	3.36	3.35	3.55	3.48	3.42	3.41	3.41	3.40
COP	RATED	3.44	3.51	3.44	3.51	3.44	3.51	3.45	3.52	3.44	3.51	3.44	3.52
Total Cooling Seasonal Performance Factor Residential - Cold / Mix / Hot		4.12 / 4.01 / 4.27		4.26 / 4.12 / 4.37		4.57 / 4.41 / 4.67		4.02 / 3.96 / 4.39		4.18 / 4.09 / 4.49		4.25 / 4.14 / 4.52	
Heating Seasonal Performance Factor Residential - Cold / Mix / Hot		1.88 / 2.08 / 3.47		2.70 / 3.17 / 4.08		2.54 / 2.98 / 4.28		2.13 / 2.41 / 4.10		1.99 / 2.21 / 3.60		1.88 / 2.08 / 3.45	
(6) INDOOR AIRFLOW (l/s) MIN. / NOMINAL / MAX.		230 / 650 / 780		260 / 770 / 920		300 / 890 / 1060		230 / 650 / 780		260 / 770 / 920		300 / 890 / 1060	
(7) OUTDOOR SOUND PRESS. LEVEL @ 3M dB(A) - Quiet / Rated / Tru.Max		45.4 / 52.4 / 54.8		47.6 / 53.5 / 56.4		47.4 / 56.4 / 56.4		45.1 / 52.0 / 54.5		47.2 / 52.7 / 55.9		47.4 / 55.9 / 55.9	
OUTDOOR SOUND POWER LEVEL dB(A) - Quiet / Rated / Tru.Max		64.1 / 71.3 / 73.6		66.0 / 72.0 / 75.1		65.7 / 75.1 / 75.1		63.6 / 70.5 / 72.9		65.5 / 71.4 / 74.6		65.7 / 74.6 / 74.6	
POWER SUPPLY - OUTDOOR		230V / 1Ph+N / 50Hz						400V / 3Ph+N / 50Hz					
VOLTAGE RANGE (MIN - MAX)		216V - 244 or 243.8V						376V - 424V					
IP RATING		IP44											
POWER SUPPLY - INDOOR		230V / 1Ph+N / 50Hz											
VOLTAGE RANGE (MIN - MAX)		216V - 244 or 243.8V											
IP RATING		IP20											
(2) RATED LOAD AMPS - TOTAL		16.7		19.5		22.8		7.2		8.5		9.7	
(8) FULL LOAD AMPS OUTDOOR / INDOOR / TOTAL		27.3 / 4.3 / 31.6		30.0 / 4.3 / 34.3		34.2 / 4.3 / 38.5		9.7 / 4.3 / 14.0		11.7 / 4.3 / 16.0		13.5 / 4.3 / 17.8	
OUTDOOR AND INDOOR UNIT (TOTAL)													
FULL LOAD AMPS - PHASE 1		31.6		34.3		38.5		14.0		16.0		17.8	
FULL LOAD AMPS - PHASE 2 AND 3				-				7.8 , 7.7		9.7 , 9.7		11.6 , 11.6	
(9) CIRCUIT BREAKER		32.0		40.0		40.0		16.0		20.0		20.0	
APPROXIMATE STARTING AMPS		< 45		< 45		< 45		< 45		< 45		< 45	
POWER FACTOR		0.99		0.99		0.99		0.92		0.93		0.93	
DATA CABLE FIELD WIRING (OUTDOOR TO INDOOR)		2 Core 7 / 0.30 (0.5mm ²) Twisted Shielded Data Cable											
WEIGHT (kg) -- INDOOR / OUTDOOR		44 / 148		53 / 148		61 / 155		44 / 148		53 / 148		61 / 155	

- (1) Based on unit rating excluding indoor fan kW.
- (2) Measured and tested in accordance with AS/NZS 3823.1.2.
- (3) At 27°C DB / 19°C WB entering air temperatures and 35°C ambient.
- (4) At 20°C DB entering air temperature and 7°C DB / 6°C WB ambient.
- (5) Total input power excludes indoor fan kW.
Nett input power includes indoor fan kW.
- (6) Max. - Min. airflow application range.
- (7) Outdoor sound pressure level is determined in an anechoic chamber and may differ once the unit is installed due to environment conditions.
- (8) Full Load Amps are based on compressor and fan motors' maximum expected current.
- (9) See Specifications sheet for circuit breaker size details.
- (10) TRUMAX - Maximum Capacity

Notes: Use nett input power to estimate running cost.
 To determine the required cable size, refer to the latest edition of AS/NZS 3000 or AS/NZS 3008 wiring rules whichever applies.
 The local electricity authority may require limits on starting current and voltage drop, please check prior to purchase.



CAPACITY SELECTION DATA

CRV13AS / EVV13AS

COOLING PERFORMANCE

AIR ENTERING		TOTAL CAPACITY kW	TOTAL SENSIBLE CAPACITY - kW							
OUTDOOR DB - °C	INDOOR WB - °C		AT DB TEMPERATURE ONTO INDOOR COIL - °C							
			20	22	24	26	27	28	30	
25	16	14.08	8.43	10.06	11.64					
	17	14.21	7.62	9.23	10.85	12.34				
	18	14.37	6.77	8.40	10.03	11.64	12.38	13.04		
	19	14.73	5.89	7.60	9.19	10.82	11.62	12.37	13.69	
	20	15.07	4.99	6.72	8.35	9.98	10.79	11.60	13.09	
	21	15.51		5.83	7.53	9.15	9.95	10.75	12.35	
	22	15.91		4.95	6.67	8.35	9.11	9.92	11.54	
35	16	13.05	7.93	9.55	11.03					
	17	13.10	7.13	8.73	10.32	11.71				
	18	13.22	6.29	7.90	9.52	11.08	11.81			
	19	13.45	5.41	7.12	8.71	10.31	11.07	11.82		
	20	13.81	4.54	6.25	7.87	9.49	10.28	11.07	12.53	
	21	14.17		5.38	7.06	8.65	9.47	10.25	11.82	
	22	14.52		4.50	6.19	7.81	8.62	9.43	11.04	
45	16	11.69	7.29	8.89						
	17	11.70	6.48	8.10	9.64					
	18	11.79	5.69	7.28	8.89	10.35				
	19	11.89	4.84	6.46	8.08	9.65	10.38	10.95		
	20	12.15	3.97	5.67	7.26	8.86	9.64	10.39		
	21	12.46		4.80	6.48	8.04	8.83	9.64	11.10	
	22	12.81		3.93	5.63	7.22	8.02	8.81	10.37	
50	16	10.92	6.94	8.50						
	17	10.93	6.14	7.75	9.21					
	18	10.98	5.36	6.93	8.52					
	19	11.01	4.51	6.13	7.72	9.26	9.93			
	20	11.23	3.65	5.33	6.91	8.49	9.27	9.98		
	21	11.51		4.48	6.13	7.68	8.49	9.27	10.64	
	22	11.81		3.61	5.30	6.88	7.68	8.47	9.99	

HEATING PERFORMANCE

WB TEMP ON OUTDOOR COIL - °C	HEATING CAPACITY - kW									
	AT DB ENTERING INDOOR - °C									
	16		18		20		22		24	
	TH	IH	TH	IH	TH	IH	TH	IH	TH	IH
-10	8.83	8.30	8.78	8.26	8.74	8.21	8.70	8.18	8.66	8.14
-6	9.81	9.03	9.76	8.98	9.70	8.92	9.64	8.87	9.58	8.81
-2	10.92	9.50	10.84	9.43	10.77	9.37	10.69	9.30	10.62	9.24
2	12.10	10.77	12.02	10.69	11.92	10.61	11.83	10.53	11.73	10.44
6	13.37	13.37	13.26	13.26	13.15	13.15	13.07	13.07	12.95	12.95
10	14.84	14.84	14.71	14.71	14.58	14.58	14.44	14.44	14.30	14.30
14	16.42	16.42	16.26	16.26	16.09	16.09	15.93	15.93	15.76	15.76
18	18.10	18.10	17.91	17.91	17.72	17.72	17.53	17.53	17.33	17.33

TH - Total Heating Capacity (kW)
IH - Integrated Heating Capacity (kW) Includes defrost losses.

AIRFLOW CORRECTION MULTIPLIER

% VARIATION	-20%	-15%	-10%	-5%	Nominal	5%	10%	15%	20%
INDOOR AIRFLOW (l/s)	520	552.5	585	617.5	650	682.5	715	747.5	780
TOTAL COOLING	0.965	0.982	0.989	0.997	1.000	1.004	1.009	1.015	1.020
SENSIBLE COOLING	0.884	0.916	0.945	0.974	1.000	1.024	1.046	1.072	1.092
HEATING FACTOR	0.969	0.976	0.983	0.991	1.000	1.011	1.022	1.033	1.044

NOTES:

- No allowance has been made for the effect of indoor fan motor.
- Selection tables are based on nominal airflows. Correction factors must be applied for selection away from these conditions.

PIPE LENGTH CORRECTION MULTIPLIER

	5m	10m	20m	30m	40m	50m	60m
COOLING	1.000	0.992	0.975	0.959	0.943	0.927	0.912
HEATING	1.000	1.000	1.000	1.000	1.000	1.000	1.000

NOTE:

Correction multipliers are based on horizontal pipe runs.



CAPACITY SELECTION DATA

CRV15AS / EVV15AS

COOLING PERFORMANCE

AIR ENTERING		TOTAL CAPACITY kW	TOTAL SENSIBLE CAPACITY - kW						
OUTDOOR DB - °C	INDOOR WB - °C		AT DB TEMPERATURE ONTO INDOOR COIL - °C						
			20	22	24	26	27	28	30
25	16	15.39	9.27	11.05	12.79				
	17	15.53	8.39	10.15	11.92	13.55			
	18	15.70	7.45	9.23	11.03	12.79	13.60	14.33	
	19	16.10	6.49	8.36	10.11	11.89	12.77	13.59	15.04
	20	16.47	5.50	7.39	9.18	10.97	11.86	12.74	14.39
	21	16.95		6.42	8.29	10.06	10.94	11.82	13.57
	22	17.38		5.46	7.34	9.18	10.02	10.90	12.68
35	16	14.26	8.72	10.50	12.12				
	17	14.32	7.85	9.60	11.34	12.87			
	18	14.45	6.92	8.69	10.47	12.18	12.97		
	19	14.70	5.96	7.83	9.57	11.33	12.17	12.99	
	20	15.10	5.00	6.88	8.65	10.43	11.30	12.16	13.76
	21	15.48		5.92	7.77	9.51	10.41	11.27	12.99
	22	15.86		4.96	6.82	8.60	9.48	10.37	12.13
45	16	13.50	7.99	9.74					
	17	13.52	7.11	8.88	10.56				
	18	13.62	6.25	7.99	9.75	11.34			
	19	13.73	5.32	7.09	8.86	10.57	11.38	12.00	
	20	14.03	4.36	6.22	7.96	9.71	10.56	11.39	
	21	14.38		5.28	7.11	8.82	9.68	10.56	12.17
	22	14.79		4.32	6.18	7.92	8.80	9.66	11.36
50	16	9.63	5.62	6.88					
	17	9.64	4.97	6.28	7.46				
	18	9.68	4.35	5.62	6.90				
	19	9.71	3.66	4.97	6.26	7.50	8.04		
	20	9.90	2.97	4.33	5.60	6.88	7.50	8.08	
	21	10.15		3.64	4.97	6.22	6.87	7.51	8.61
	22	10.42		2.93	4.30		6.22	6.86	8.09

HEATING PERFORMANCE

WB TEMP ON OUTDOOR COIL - °C	HEATING CAPACITY - kW									
	AT DB ENTERING INDOOR - °C									
	16		18		20		22		24	
	TH	IH	TH	IH	TH	IH	TH	IH	TH	IH
-10	10.10	7.80	10.05	7.76	10.00	7.72	9.96	7.69	9.91	7.65
-6	11.40	8.51	11.34	8.46	11.27	8.41	11.20	8.36	11.13	8.30
-2	12.71	9.22	12.63	9.15	12.54	9.09	12.45	9.03	12.37	8.96
2	14.03	10.87	13.93	10.79	13.82	10.70	13.71	10.62	13.60	10.54
6	15.35	15.35	15.23	15.23	15.10	15.10	15.01	15.01	14.87	14.87
10	17.05	17.05	16.90	16.90	16.74	16.74	16.58	16.58	16.42	16.42
14	18.86	18.86	18.67	18.67	18.48	18.48	18.29	18.29	18.10	18.10
18	20.78	20.78	20.57	20.57	20.35	20.35	20.14	20.14	19.90	19.90

TH - Total Heating Capacity (kW)
 IH - Integrated Heating Capacity (kW) Includes defrost losses.

AIRFLOW CORRECTION MULTIPLIER

% VARIATION	-20%	-15%	-10%	-5%	Nominal	5%	10%	15%	19.48
INDOOR AIRFLOW (l/s)	616	654.5	693	731.5	770	808.5	847	885.5	920
TOTAL COOLING	0.965	0.982	0.989	0.997	1.000	1.004	1.009	1.015	1.020
SENSIBLE COOLING	0.884	0.916	0.945	0.974	1.000	1.024	1.046	1.072	1.092
HEATING FACTOR	0.969	0.976	0.983	0.991	1.000	1.011	1.022	1.033	1.044

NOTES:

- No allowance has been made for the effect of indoor fan motor.
- Selection tables are based on nominal airflows. Correction factors must be applied for selection away from these conditions.

PIPE LENGTH CORRECTION MULTIPLIER

	5m	10m	20m	30m	40m	50m	60m
COOLING	1.000	0.992	0.975	0.959	0.943	0.927	0.912
HEATING	1.000	1.000	1.000	1.000	1.000	1.000	1.000

NOTE:

Correction multipliers are based on horizontal pipe runs.



CAPACITY SELECTION DATA

CRV17AS / EVV17AS

COOLING PERFORMANCE

AIR ENTERING		TOTAL CAPACITY kW	TOTAL SENSIBLE CAPACITY - kW						
OUTDOOR DB - °C	INDOOR WB - °C		AT DB TEMPERATURE ONTO INDOOR COIL - °C						
			20	22	24	26	27	28	30
25	16	17.95	10.71	12.77	14.77				
	17	18.12	9.69	11.72	13.77	15.65			
	18	18.32	8.60	10.66	12.74	14.77	15.70	16.55	
	19	18.79	7.49	9.65	11.67	13.73	14.75	15.70	17.37
	20	19.22	6.36	8.54	10.61	12.67	13.70	14.72	16.61
	21	19.77		7.41	9.57	11.62	12.63	13.65	15.67
	22	20.28		6.31	8.47	10.60	11.57	12.59	14.64
35	16	16.64	10.07	12.12	14.00				
	17	16.70	9.06	11.09	13.10	14.86			
	18	16.86	8.00	10.04	12.09	14.07	14.98		
	19	17.15	6.89	9.04	11.06	13.09	14.06	15.00	
	20	17.61	5.78	7.95	9.99	12.05	13.06	14.05	15.89
	21	18.06		6.84	8.97	10.98	12.02	13.02	15.00
	22	18.51		5.73	7.88	9.93	10.95	11.97	14.01
45	16	15.77	9.69	11.80					
	17	15.79	8.62	10.76	12.80				
	18	15.90	7.58	9.68	11.81	13.74			
	19	16.03	6.45	8.59	10.74	12.81	13.79	14.54	
	20	16.39	5.29	7.54	9.65	11.77	12.80	13.80	
	21	16.80		6.40	8.61	10.68	11.73	12.80	14.74
	22	17.27		5.24	7.49	9.60	10.66	11.71	13.77
50	16	11.23	7.46	9.13					
	17	11.24	6.60	8.33	9.89				
	18	11.29	5.77	7.45	9.15				
	19	11.33	4.86	6.59	8.30	9.95	10.66		
	20	11.56	3.94	5.74	7.43	9.12	9.95	10.71	
	21	11.84		4.83	6.60	8.25	9.12	9.96	11.42
	22	12.15		3.89	5.70	7.40	8.25	9.10	10.73

HEATING PERFORMANCE

WB TEMP ON OUTDOOR COIL - °C	HEATING CAPACITY - kW									
	AT DB ENTERING INDOOR - °C									
	16		18		20		22		24	
	TH	IH	TH	IH	TH	IH	TH	IH	TH	IH
-10	11.62	9.85	11.56	9.80	11.50	9.75	11.45	9.71	11.40	9.66
-6	12.96	10.26	12.88	10.20	12.80	10.14	12.73	10.08	12.65	10.01
-2	14.39	10.68	14.29	10.61	14.20	10.53	14.09	10.46	14.00	10.39
2	15.92	12.30	15.80	12.21	15.68	12.11	15.56	12.02	15.43	11.92
6	17.54	17.54	17.40	17.39	17.25	17.25	17.15	17.15	16.99	16.99
10	19.47	19.47	19.30	19.30	19.12	19.12	18.95	18.95	18.76	18.76
14	21.54	21.54	21.33	21.33	21.11	21.11	20.90	20.90	20.68	20.68
18	23.75	23.75	23.50	23.50	23.25	23.25	23.00	23.00	22.74	22.74

TH - Total Heating Capacity (kW)
IH - Integrated Heating Capacity (kW) Includes defrost losses.

AIRFLOW CORRECTION MULTIPLIER

% VARIATION	-20%	-15%	-10%	-5%	Nominal	5%	10%	15%	19.1
INDOOR AIRFLOW (l/s)	712	756.5	801	845.5	890	934.5	979	1023.5	1060
TOTAL COOLING	0.965	0.982	0.989	0.997	1.000	1.004	1.009	1.015	1.020
SENSIBLE COOLING	0.884	0.916	0.945	0.974	1.000	1.024	1.046	1.072	1.092
HEATING FACTOR	0.969	0.976	0.983	0.991	1.000	1.011	1.022	1.033	1.044

NOTES:

- No allowance has been made for the effect of indoor fan motor.
- Selection tables are based on nominal airflows. Correction factors must be applied for selection away from these conditions.

PIPE LENGTH CORRECTION MULTIPLIER

	5m	10m	20m	30m	40m	50m	60m
COOLING	1.000	0.992	0.975	0.959	0.943	0.927	0.912
HEATING	1.000	1.000	1.000	1.000	1.000	1.000	1.000

NOTE:

Correction multipliers are based on horizontal pipe runs.



CAPACITY SELECTION DATA

CRV13AT / EVV13AS

COOLING PERFORMANCE

AIR ENTERING		TOTAL CAPACITY kW	TOTAL SENSIBLE CAPACITY - kW							
OUTDOOR DB - °C	INDOOR WB - °C		AT DB TEMPERATURE ONTO INDOOR COIL - °C							
			20	22	24	26	27	28	30	
25	16	13.67	8.09	9.65	11.17					
	17	13.80	7.32	8.86	10.41	11.84				
	18	13.95	6.50	8.06	9.63	11.17	11.87	12.51		
	19	14.31	5.66	7.30	8.83	10.38	11.15	11.87	13.14	
	20	14.64	4.80	6.46	8.02	9.58	10.36	11.13	12.56	
	21	15.06		5.60	7.24	8.79	9.55	10.32	11.85	
	22	15.45		4.77	6.41	8.02	8.75	9.52	11.07	
35	16	12.67	7.61	9.17	10.58					
	17	12.72	6.85	8.38	9.91	11.24				
	18	12.84	6.05	7.59	9.14	10.64	11.33			
	19	13.06	5.21	6.84	8.36	9.90	10.63	11.35		
	20	13.41	4.37	6.01	7.56	9.11	9.87	10.62	12.02	
	21	13.75		5.17	6.78	8.31	9.09	9.84	11.34	
	22	14.09		4.33	5.95	7.51	8.28	9.05	10.59	
45	16	11.36	7.00	8.53						
	17	11.37	6.23	7.77	9.25					
	18	11.45	5.47	6.99	8.54	9.93				
	19	11.54	4.66	6.21	7.76	9.26	9.96	10.51		
	20	11.80	3.82	5.45	6.97	8.50	9.25	9.97		
	21	12.10		4.62	6.22	7.72	8.48	9.25	10.66	
	22	12.44		3.78	5.41	6.94	7.71	8.46	9.95	
50	16	10.60	6.67	8.16						
	17	10.62	5.90	7.44	8.84					
	18	10.66	5.15	6.66	8.18					
	19	10.70	4.34	5.89	7.42	8.89	9.53			
	20	10.91	3.52	5.13	6.64	8.15	8.90	9.58		
	21	11.18		4.32	5.90	7.38	8.15	8.90	10.21	
	22	11.47		3.47	5.10	6.61	7.37	8.13	9.59	

HEATING PERFORMANCE

WB TEMP ON OUTDOOR COIL - °C	HEATING CAPACITY - kW									
	AT DB ENTERING INDOOR - °C									
	16		18		20		22		24	
	TH	IH	TH	IH	TH	IH	TH	IH	TH	IH
-10	8.99	8.45	8.94	8.41	8.90	8.36	8.86	8.33	8.82	8.29
-6	9.99	9.19	9.93	9.14	9.87	9.08	9.82	9.03	9.75	8.97
-2	11.12	9.67	11.04	9.61	10.97	9.54	10.89	9.47	10.81	9.41
2	12.32	10.97	12.23	10.89	12.14	10.80	12.04	10.72	11.95	10.63
6	13.61	13.61	13.50	13.50	13.39	13.39	13.31	13.31	13.19	13.19
10	15.12	15.12	14.98	14.98	14.84	14.84	14.71	14.71	14.56	14.56
14	16.72	16.72	16.55	16.55	16.38	16.38	16.22	16.22	16.05	16.05
18	18.43	18.43	18.24	18.24	18.04	18.04	17.85	17.85	17.65	17.65

TH - Total Heating Capacity (kW)
IH - Integrated Heating Capacity (kW) Includes defrost losses.

AIRFLOW CORRECTION MULTIPLIER

% VARIATION	-20%	-15%	-10%	-5%	Nominal	5%	10%	15%	20%
INDOOR AIRFLOW (l/s)	520	552.5	585	617.5	650	682.5	715	747.5	780
TOTAL COOLING	0.965	0.982	0.989	0.997	1.000	1.004	1.009	1.015	1.020
SENSIBLE COOLING	0.884	0.916	0.945	0.974	1.000	1.024	1.046	1.072	1.092
HEATING FACTOR	0.969	0.976	0.983	0.991	1.000	1.011	1.022	1.033	1.044

NOTES:

- No allowance has been made for the effect of indoor fan motor.
- Selection tables are based on nominal airflows. Correction factors must be applied for selection away from these conditions.

PIPE LENGTH CORRECTION MULTIPLIER

	5m	10m	20m	30m	40m	50m	60m
COOLING	1.000	0.992	0.975	0.959	0.943	0.927	0.912
HEATING	1.000	1.000	1.000	1.000	1.000	1.000	1.000

NOTE:

Correction multipliers are based on horizontal pipe runs.



CAPACITY SELECTION DATA

CRV15AT / EVV15AS

COOLING PERFORMANCE

AIR ENTERING		TOTAL CAPACITY kW	TOTAL SENSIBLE CAPACITY - kW						
OUTDOOR DB - °C	INDOOR WB - °C		AT DB TEMPERATURE ONTO INDOOR COIL - °C						
			20	22	24	26	27	28	30
25	16	15.75	9.42	11.23	12.99				
	17	15.90	8.52	10.31	12.12	13.77			
	18	16.08	7.56	9.38	11.21	13.00	13.82	14.56	
	19	16.49	6.59	8.49	10.27	12.08	12.98	13.81	15.29
	20	16.86	5.59	7.51	9.33	11.15	12.06	12.95	14.62
	21	17.35		6.52	8.42	10.22	11.12	12.01	13.79
	22	17.80		5.54	7.45	9.33	10.18	11.08	12.88
35	16	14.60	8.86	10.66	12.32				
	17	14.66	7.97	9.76	11.53	13.08			
	18	14.79	7.03	8.83	10.64	12.38	13.18		
	19	15.05	6.06	7.95	9.73	11.52	12.37	13.20	
	20	15.46	5.08	6.99	8.79	10.60	11.49	12.36	13.99
	21	15.85		6.02	7.89	9.66	10.58	11.45	13.20
	22	16.24		5.03	6.93	8.73	9.63	10.53	12.33
45	16	14.44	8.44	10.29					
	17	14.45	7.51	9.38	11.16				
	18	14.56	6.60	8.43	10.29	11.98			
	19	14.68	5.62	7.48	9.36	11.17	12.02	12.68	
	20	15.01	4.61	6.57	8.41	10.25	11.16	12.03	
	21	15.38		5.57	7.51	9.31	10.22	11.16	12.85
	22	15.81		4.56	6.53	8.36	9.29	10.20	12.00
50	16	11.46	7.40	9.06					
	17	11.48	6.55	8.27	9.82				
	18	11.53	5.72	7.39	9.08				
	19	11.57	4.82	6.54	8.24	9.87	10.59		
	20	11.79	3.91	5.69	7.38	9.06	9.88	10.64	
	21	12.09		4.79	6.55	8.19	9.05	9.89	11.34
	22	12.40		3.86	5.66	7.34	8.19	9.03	10.65

HEATING PERFORMANCE

WB TEMP ON OUTDOOR COIL - °C	HEATING CAPACITY - kW									
	AT DB ENTERING INDOOR - °C									
	16		18		20		22		24	
	TH	IH	TH	IH	TH	IH	TH	IH	TH	IH
-10	10.10	7.80	10.05	7.76	10.00	7.72	9.96	7.69	9.91	7.65
-6	10.84	7.81	10.77	7.77	10.71	7.72	10.65	7.67	10.58	7.62
-2	12.06	7.81	11.98	7.76	11.90	7.71	11.81	7.65	11.73	7.60
2	13.77	9.44	13.67	9.37	13.56	9.30	13.45	9.23	13.35	9.15
6	15.96	15.96	15.83	15.83	15.70	15.70	15.61	15.61	15.46	15.46
10	17.72	17.72	17.57	17.57	17.40	17.40	17.24	17.24	17.07	17.07
14	19.60	19.60	19.41	19.41	19.21	19.21	19.01	19.01	18.82	18.82
18	21.61	21.61	21.38	21.38	21.16	21.16	20.93	20.93	20.69	20.69

TH - Total Heating Capacity (kW)
IH - Integrated Heating Capacity (kW) Includes defrost losses.

AIRFLOW CORRECTION MULTIPLIER

% VARIATION	-20%	-15%	-10%	-5%	Nominal	5%	10%	15%	19.48
INDOOR AIRFLOW (l/s)	616	654.5	693	731.5	770	808.5	847	885.5	920
TOTAL COOLING	0.965	0.982	0.989	0.997	1.000	1.004	1.009	1.015	1.020
SENSIBLE COOLING	0.884	0.916	0.945	0.974	1.000	1.024	1.046	1.072	1.092
HEATING FACTOR	0.969	0.976	0.983	0.991	1.000	1.011	1.022	1.033	1.044

NOTES:

- No allowance has been made for the effect of indoor fan motor.
- Selection tables are based on nominal airflows. Correction factors must be applied for selection away from these conditions.

PIPE LENGTH CORRECTION MULTIPLIER

	5m	10m	20m	30m	40m	50m	60m
COOLING	1.000	0.992	0.975	0.959	0.943	0.927	0.912
HEATING	1.000	1.000	1.000	1.000	1.000	1.000	1.000

NOTE:

Correction multipliers are based on horizontal pipe runs.



CAPACITY SELECTION DATA

CRV17AT / EVV17AS

COOLING PERFORMANCE									
AIR ENTERING		TOTAL CAPACITY kW	TOTAL SENSIBLE CAPACITY - kW						
OUTDOOR DB - °C	INDOOR WB - °C		AT DB TEMPERATURE ONTO INDOOR COIL - °C						
			20	22	24	26	27	28	30
25	16	18.16	10.88	12.98	15.01				
	17	18.33	9.85	11.92	14.00	15.92			
	18	18.54	8.74	10.84	12.95	15.02	15.97	16.82	
	19	19.00	7.62	9.81	11.87	13.96	14.99	15.96	17.66
	20	19.44	6.46	8.68	10.78	12.88	13.93	14.96	16.89
	21	20.00		7.53	9.73	11.81	12.84	13.88	15.93
	22	20.52		6.41	8.61	10.78	11.76	12.80	14.89
35	16	16.83	10.23	12.32	14.23				
	17	16.90	9.21	11.27	13.32	15.11			
	18	17.05	8.13	10.20	12.29	14.30	15.23		
	19	17.35	7.00	9.19	11.24	13.31	14.29	15.26	
	20	17.82	5.87	8.08	10.16	12.25	13.27	14.28	16.16
	21	18.27		6.95	9.12	11.17	12.22	13.23	15.25
	22	18.72		5.82	8.00	10.09	11.13	12.17	14.24
45	16	16.65	9.75	11.88					
	17	16.66	8.68	10.83	12.89				
	18	16.78	7.62	9.74	11.89	13.83			
	19	16.92	6.49	8.64	10.81	12.90	13.88	14.64	
	20	17.30	5.32	7.59	9.71	11.85	12.89	13.89	
	21	17.73		6.44	8.67	10.75	11.81	12.89	14.84
	22	18.23		5.27	7.54	9.66	10.74	11.79	13.86
50	16	13.22	8.55	10.47					
	17	13.23	7.56	9.55	11.34				
	18	13.29	6.61	8.54	10.49				
	19	13.34	5.57	7.56	9.52	11.41	12.23		
	20	13.60	4.51	6.58	8.52	10.46	11.41	12.29	
	21	13.94		5.54	7.56	9.47	10.46	11.42	13.09
	22	14.30		4.46	6.54	8.48	9.46	10.43	12.30

HEATING PERFORMANCE										
WB TEMP ON OUTDOOR COIL - °C	HEATING CAPACITY - kW									
	AT DB ENTERING INDOOR - °C									
	16		18		20		22		24	
	TH	IH	TH	IH	TH	IH	TH	IH	TH	IH
-10	11.62	9.85	11.56	9.80	11.50	9.75	11.45	9.71	11.40	9.66
-6	12.58	9.25	12.51	9.19	12.44	9.14	12.36	9.08	12.28	9.02
-2	14.03	8.65	13.93	8.59	13.84	8.53	13.74	8.47	13.65	8.41
2	15.95	10.22	15.84	10.15	15.71	10.07	15.59	9.99	15.46	9.91
6	18.35	18.35	18.20	18.20	18.05	18.05	17.94	17.94	17.78	17.78
10	20.38	20.38	20.20	20.20	20.01	20.01	19.82	19.82	19.63	19.63
14	22.54	22.54	22.31	22.31	22.08	22.08	21.86	21.86	21.63	21.63
18	24.84	24.84	24.58	24.58	24.32	24.32	24.07	24.07	23.79	23.79

TH - Total Heating Capacity (kW)
 IH - Integrated Heating Capacity (kW) Includes defrost losses.

AIRFLOW CORRECTION MULTIPLIER									
% VARIATION	-20%	-15%	-10%	-5%	Nominal	5%	10%	15%	19.1
INDOOR AIRFLOW (l/s)	712	756.5	801	845.5	890	934.5	979	1023.5	1060
TOTAL COOLING	0.965	0.982	0.989	0.997	1.000	1.004	1.009	1.015	1.020
SENSIBLE COOLING	0.884	0.916	0.945	0.974	1.000	1.024	1.046	1.072	1.092
HEATING FACTOR	0.969	0.976	0.983	0.991	1.000	1.011	1.022	1.033	1.044

- NOTES:
- No allowance has been made for the effect of indoor fan motor.
 - Selection tables are based on nominal airflows. Correction factors must be applied for selection away from these conditions.

PIPE LENGTH CORRECTION MULTIPLIER							
	5m	10m	20m	30m	40m	50m	60m
COOLING	1.000	0.992	0.975	0.959	0.943	0.927	0.912
HEATING	1.000	1.000	1.000	1.000	1.000	1.000	1.000

NOTE:
 Correction multipliers are based on horizontal pipe runs.



THREE SPEED FAN CURVE

EVV13AS

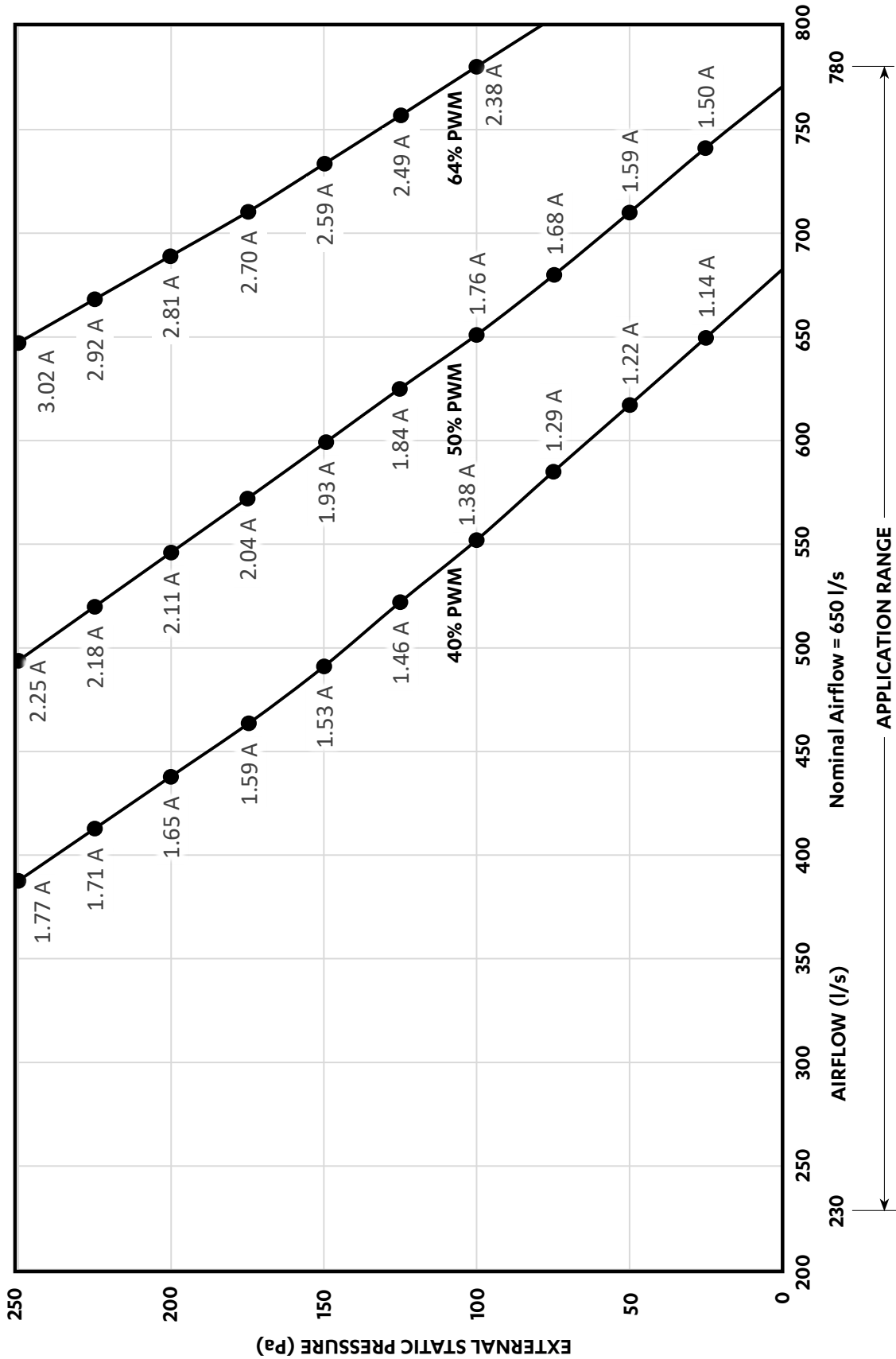

THREE SPEED FAN CURVE

EVV15AS

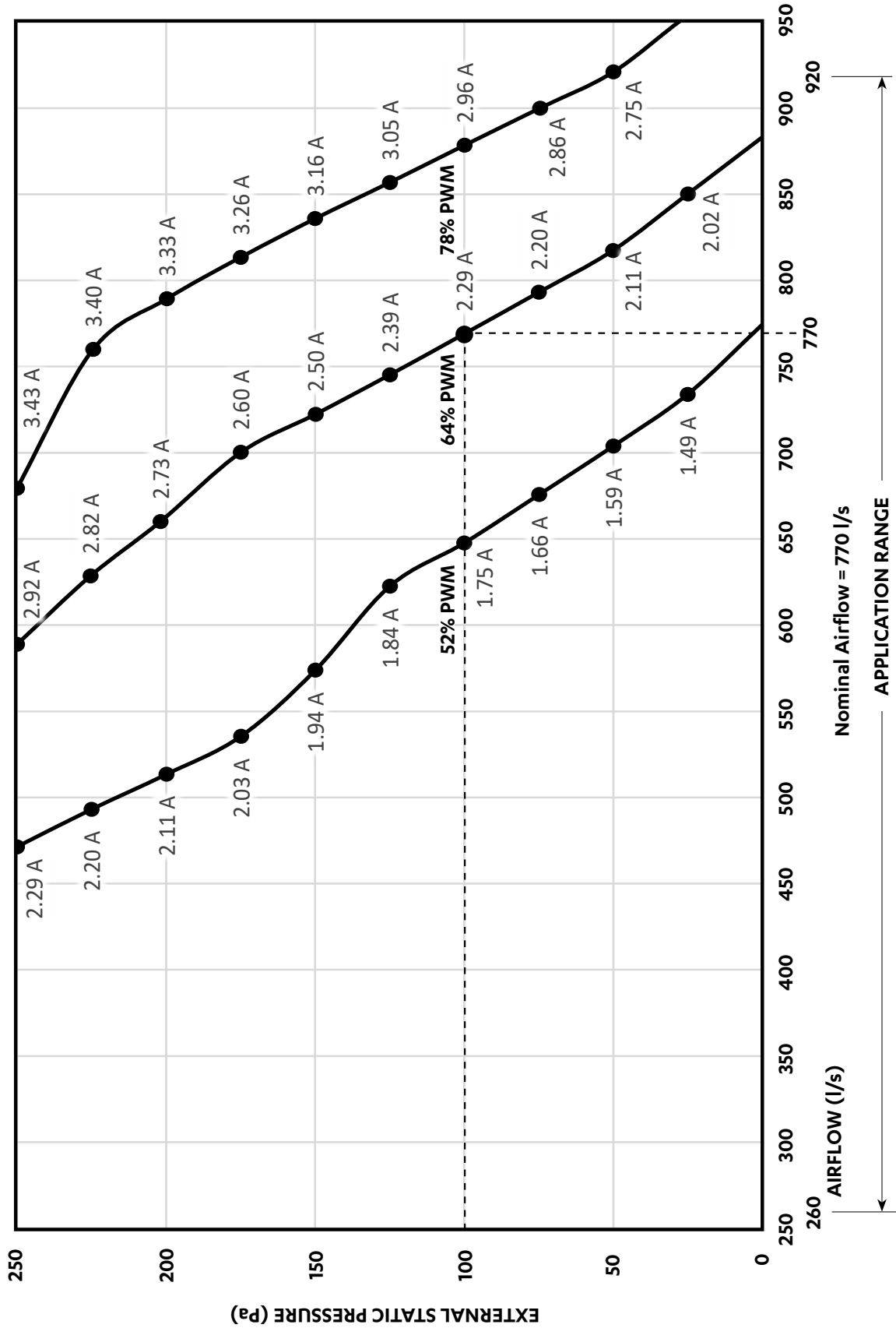

THREE SPEED FAN CURVE

EVV17AS

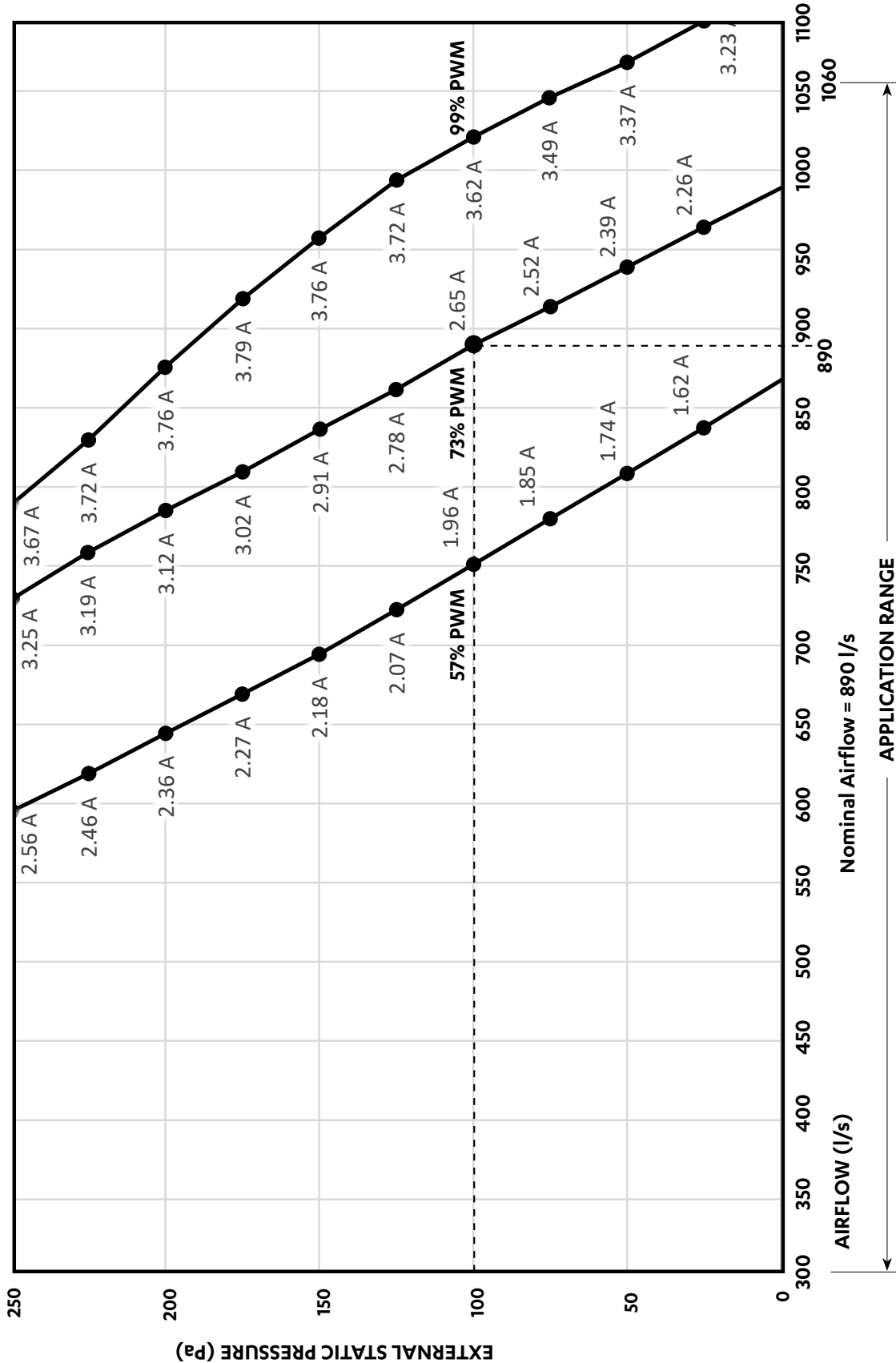

THIRD PARTY FAN CURVE

EVV13AS

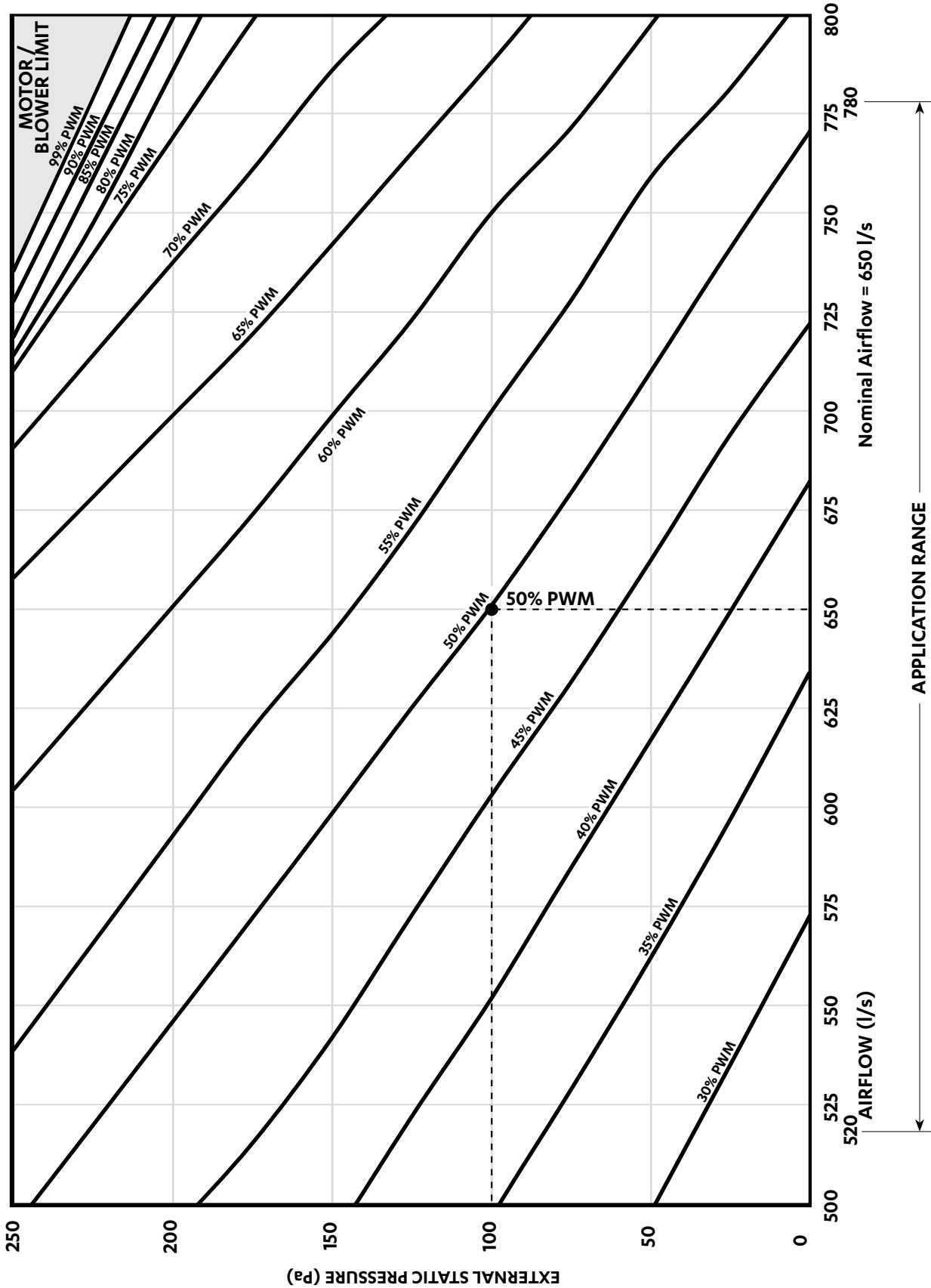

NOTE

Fan Performance Data and Fan Curve shown is at dry coil and with no air filters installed. Consider external static pressure drop specific to your design requirements. Airflow should be reduced with respect to the moisture content in the air. Please review filter manufacturer for application. 2.5 m/s face velocity point will occur outside the application range.



THIRD PARTY FAN CURVE

EVV15AS

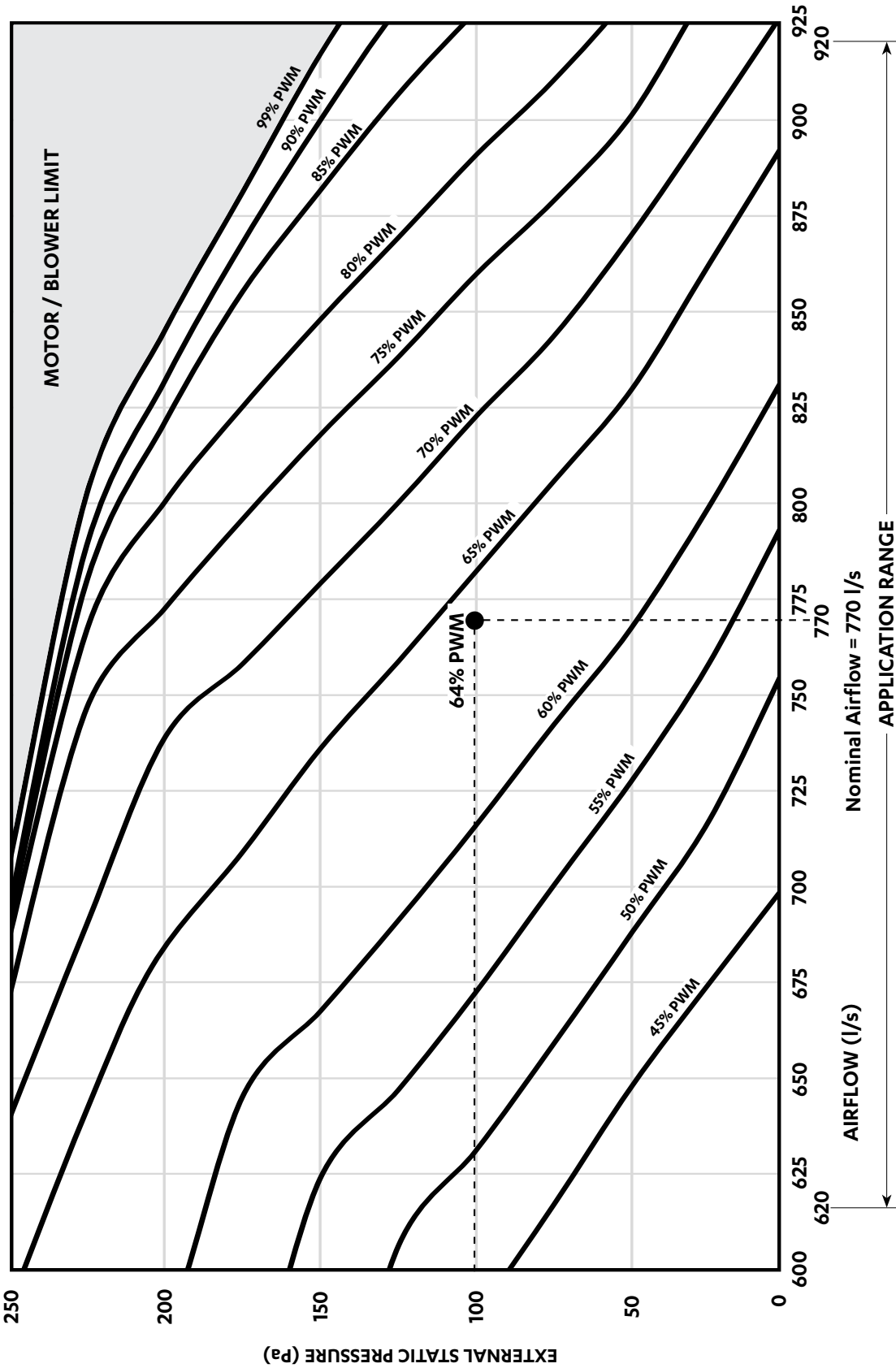

NOTE
 Fan Performance Data and Fan Curve shown is at dry coil and with no air filters installed. Consider external static pressure drop specific to your design requirements. Airflow should be reduced with respect to the moisture content in the air. Please review filter manufacturer for application. 2.5 m/s face velocity point will occur outside the application range.



THIRD PARTY FAN CURVE

EVV17AS

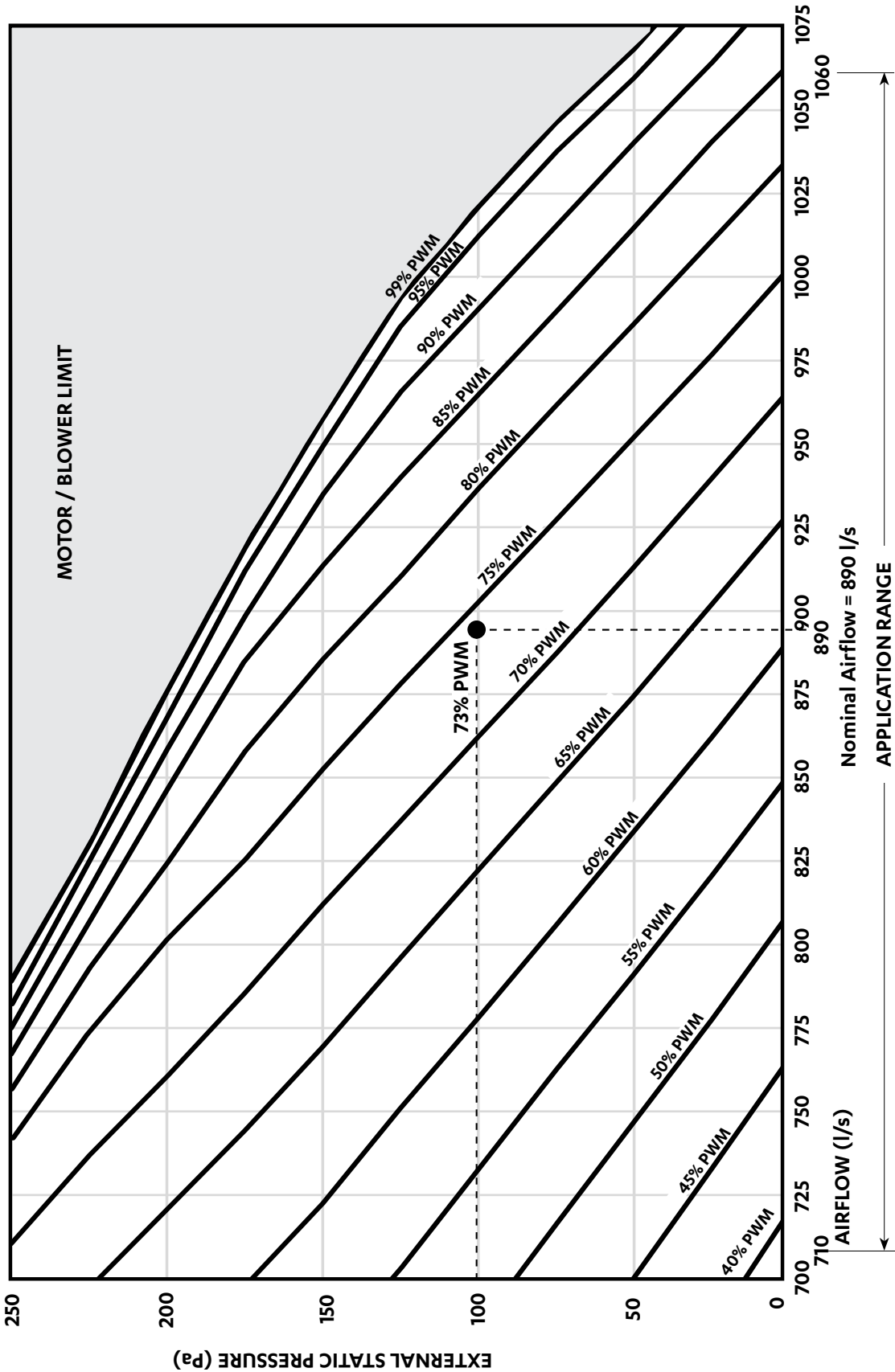

NOTE
 Fan Performance Data and Fan Curve shown is at dry coil and with no air filters installed. Consider external static pressure drop specific to your design requirements. Airflow should be reduced with respect to the moisture content in the air. Please review filter manufacturer for application. 2.5 m/s face velocity point will occur outside the application range.



OUTDOOR UNIT DIMENSIONS

CRV13AS / CRV13AT / CRV15AS / CRV15AT / CRV17AS / CRV17AT

NOTES:

Condensation points are designed to ensure all condensation is removed efficiently to avoid water pooling with the condenser. If a single condensation drain point is required, ActronAir recommends the installation of a condenser tray. These are available as an additional accessory and are purchased separately.

Drawing is subject to change without notice.

CRV17AS / CRV17AT models shown for illustration purposes only.

**Air Inlet is only for CRV17AS / CRV17AT models which have coil curve.

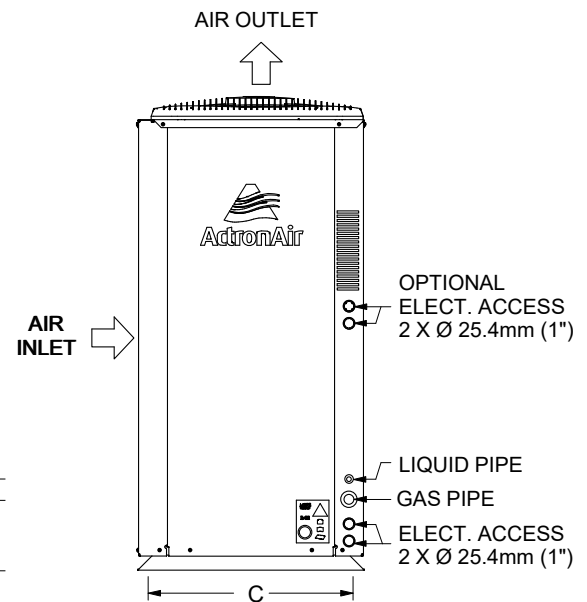
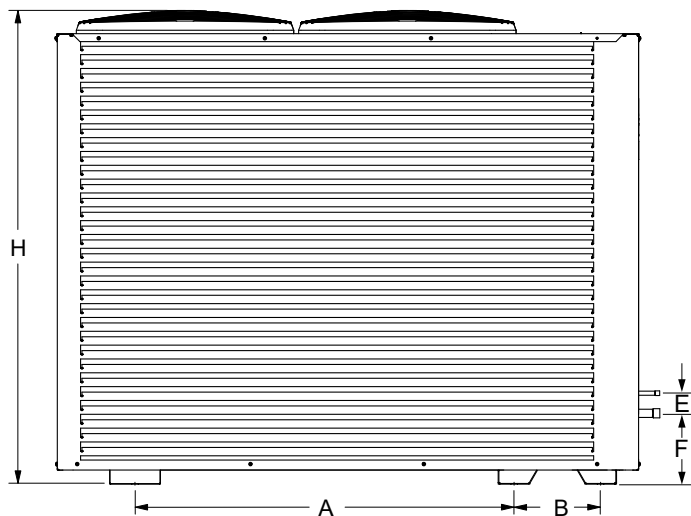
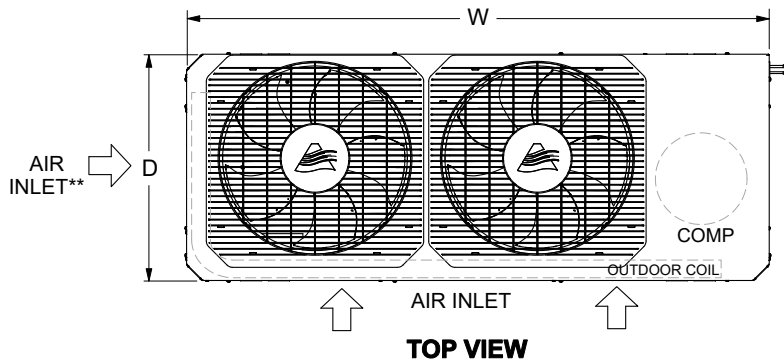

Unit Model Number	Overall Nominal Dimension (OA)			Mounting Distance Base Foot (Centre to Centre)			Pipe Location		Gas Pipe	Liquid Pipe
	H	W	D	A	B	C	E	F		
CRV13AS / CRV13AT	1110	1365	530	887	202	480	47	166	Ø 19.05mm (3/4") Swaged	Ø 9.52 mm (3/8") Swaged
CRV15AS / CRV15AT										
CRV17AS / CRV17AT										



INDOOR UNIT DIMENSIONS

EVV13AS / EVV15AS / EVV17AS

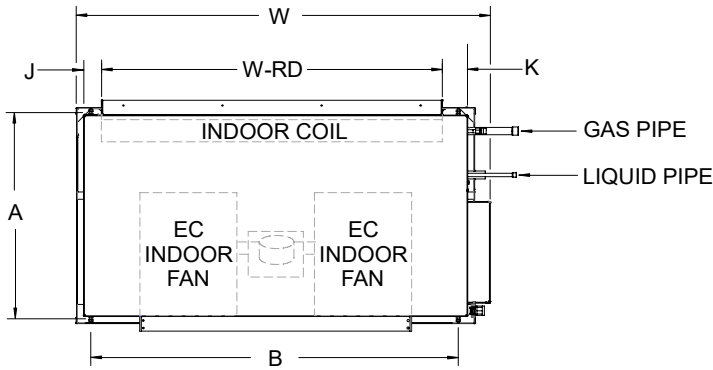

TOP VIEW

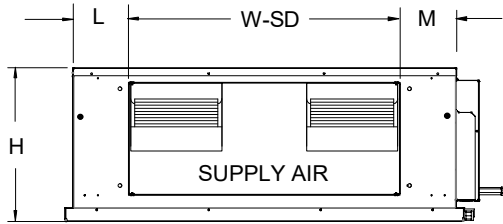

FRONT VIEW

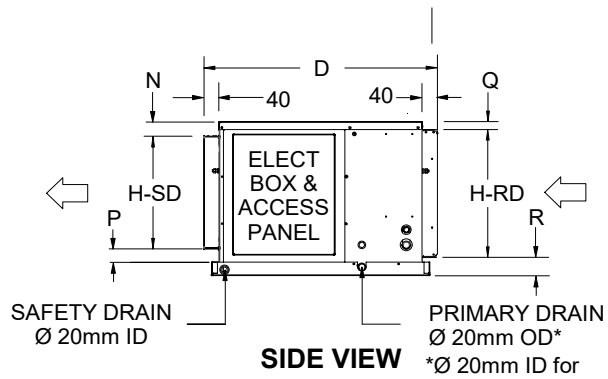

SIDE VIEW

NOTES:

Drawing is subject to change without notice.
Image shown is for illustration purpose only.
Actual unit may vary depending on unit model.

Unit Model Number	Overall Nominal Dimension (OA)			Mounting Distance Base Foot (Centre to Centre)		Supply Duct	Return Duct	Gas Pipe	Liquid Pipe
	H	W	D	A	B	H-SD x W-SD	H-RD x W-RD		
EVV13AS	412	1090	615	548	990	300 x 715	340 x 900	Ø 19.05mm (3/4") Swaged	Ø 9.52mm (3/8") Swaged
EVV15AS		1290			1190		340 x 1100		
EVV17AS	435	1420	680	603	1315		360 x 1140		

Unit Model Number	Dimensions							
	J	K	L	M	N	P	Q	R
EVV13AS	47	65	248.5	248.5	40	72	22	50
EVV15AS	47	65	248.5	248.5	40	72	22	50
EVV17AS	79	118	311	311	25	110	25	50

INDOOR UNIT DIMENSIONS

NOTES:

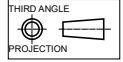

1. Do not scale drawing. All dimensions are in mm unless specified. Refer to corresponding unit dimensional drawing for mounting hole details.
2. Service Access Areas and Spaces for Airflow Clearances are suggested minimum based on the condition that the spaces around the units are free from any obstructions and a walkaway passage of 1000 mm between the units or between the unit and the outside perimeter is available.
3. Minimum service access areas and spaces for airflow clearances are responsibilities of the installer, ActronAir will not be held liable for any extra charges incurred due to lack of access and space for airflow.
 - Left Service Clearance can be 100mm minimum if Right Service Clearance is applicable.
 - Right Service Clearance can be 600mm minimum if Left Service Clearance is applicable.
 - Height Service Clearance can be 100mm minimum if Right Service Clearance is applicable.
4. Installation of this unit should be in accordance with AS/NZS 60335.2.40.
5. During installation ensure that the Minimum Floor Area of the smallest room is satisfied based on the Release height, or the maximum R-32 Charge amount is not exceeded.
6. Where a minimum area is not satisfied, the installer must provide additional control measure/s such as but not limited to ventilation, shut-off valves, and safety alarm in place as per AS/NZS 60335.2.40 standard for the installation to be acceptable. These control measures are not provided by ActronAir and must be determined by the installer based on individual installation requirements.
7. Refer to R-32 Safety Manual for further safety guides.

SERVICE CLEARANCES, AIRFLOW ALLOWANCES AND WEIGHTS

OUTDOOR UNIT

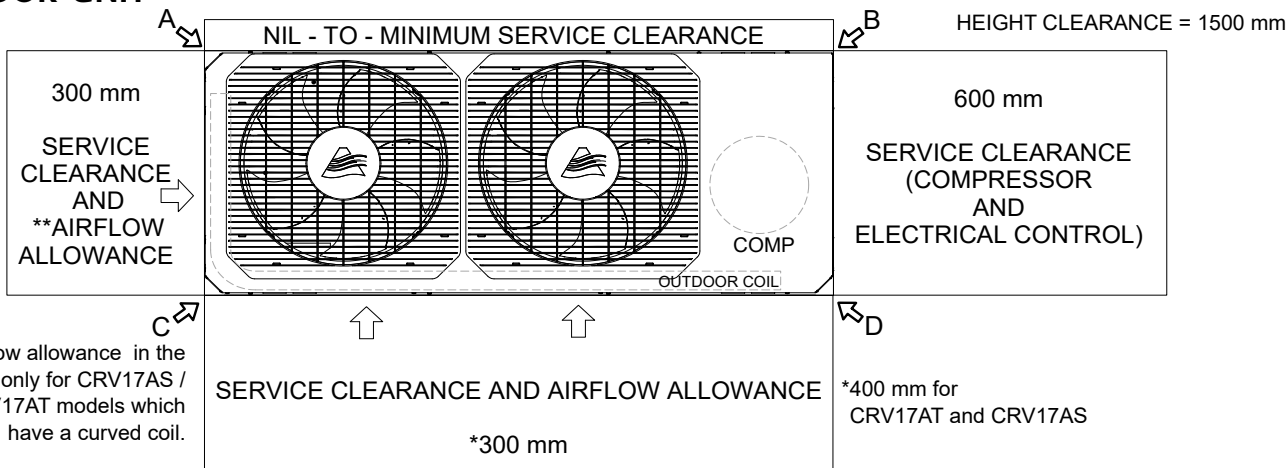

Unit Model Number	Total Weight (Kg)	Corner Weights (Kg)			
		A	B	C	D
CRV13AS	148	24	46	28	50
CRV15AS					
CRV17AS	155	36	38	30	51
CRV13AT	148	24	46	28	50
CRV15AT					
CRV17AT	155	36	38	30	51

NOTES:

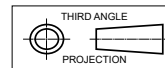

- Do not scale drawing. All dimensions are in **mm** unless otherwise specified. Refer to corresponding unit dimensional drawing for mounting hole details.
- Service Access Areas and Spaces for Airflow Clearances are suggested minimum based on the condition that the spaces around the units are free from any obstructions and a walkway passage of 1000 mm between the units or between the unit and the outside perimeter is available.
- Minimum service access areas and spaces for airflow clearances are responsibilities of the installer, ActronAir will not be held liable for any extra charges incurred due to lack of access and space for airflow.
- Under all circumstances, condenser air must not recirculate back onto condenser coil. Keep all clearance free of any obstruction.
- Refer Pipe Connection Details on Specifications Sheet.
- Use M12 bolt for feet mounting.
- For installation with release height less than or equal to 0.6m, minimum area will be computed based on release height of 0.6m.
- Where A min (the minimum area required) is not satisfied, the installer must provide additional control measure/s in place as per AS/NZS 60335.2.40 standard for the installation to be acceptable.

The examples of controls measures are (but are not limited to): Ventilation, Shut Off Valves and Safety Alarm. These control measures are not provided by ActronAir and must be determined by the installer based on individual installation requirements

- Refer to R-32 Safety Manual for minimum required area of installation.

INDOOR UNIT

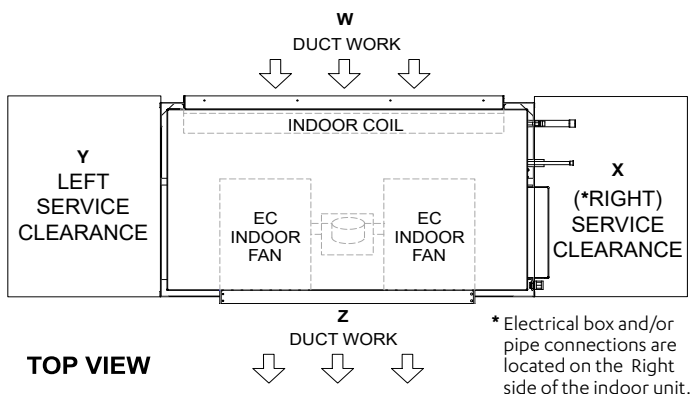

Unit Model Number	Total Weight (Kg)	Service Clearance				Height Clearance
		X	Y	W	Z	
EVV13AS	44	800	800	Duct Work	340	
EVV15AS	53	800	800	Duct Work	340	
EVV17AS	61	800	800	Duct Work	410	

SOUND DATA

OUTDOOR RADIATED

Sound Power Level (SWL)

Model Number		Sound Power Level dB(A)	Sound Pressure Level dB(A)	Octave Band Centre Frequency (Hz), dB						
				125	250	500	1k	2k	4k	8k
CRV13AS/EVV13AS	Tru.Max	73.6	54.8	77.4	73.7	71.8	67.9	63.3	58.4	48.4
	Rated	71.3	52.4	75.4	71.3	69.3	65.6	61.1	55.9	45.5
	Quiet	64.1	45.4	68.6	63.7	61.8	58.4	54.4	47.8	36.6
CRV15AS/EVV15AS	Tru.Max	75.1	56.4	79.5	76.6	72.9	69.2	64.3	59.7	54.9
	Rated	72.0	53.5	75.4	72.2	70.1	66.4	61.8	56.8	46.5
	Quiet	66.0	47.6	68.9	65.6	63.9	60.5	56.4	50.3	39.0
CRV17AS/EVV17AS	Tru.Max	75.1	56.4	79.5	76.6	72.9	69.2	64.3	59.7	54.9
	Rated	75.1	56.4	79.5	76.6	72.9	69.2	64.3	59.7	54.9
	Quiet	65.7	47.4	69.0	66.0	63.4	60.2	56.2	50.8	39.2
CRV13AT/EVV13AS	Tru.Max	72.9	54.5	76.9	73.0	70.6	67.5	62.9	58.4	48.6
	Rated	70.5	52.0	74.7	70.8	68.1	65.1	60.7	55.9	45.5
	Quiet	63.6	45.1	67.4	63.6	61.2	58.2	54.2	48.2	36.7
CRV15AT/EVV15AS	Tru.Max	74.6	55.9	78.2	75.1	72.5	69.3	64.5	60.1	50.7
	Rated	71.4	52.7	74.9	71.6	69.1	66.1	61.4	56.8	46.7
	Quiet	65.5	47.2	68.8	65.8	63.2	60.0	56.0	50.6	39.0
CRV17AT/EVV17AS	Tru.Max	74.6	55.9	78.2	75.1	72.5	69.3	64.5	60.1	50.7
	Rated	74.6	55.9	78.2	75.1	72.5	69.3	64.5	60.1	50.7
	Quiet	65.7	47.4	69.0	66.0	63.4	60.2	56.2	50.8	39.2

INDOOR OUTLET

Sound Power Level (SWL)

Model Number	Airflow Setting	Airflow l/s	Sound Power Level dB(A)	Octave Band Centre Frequency (Hz), dB						
				125	250	500	1k	2k	4k	8k
CRV13AS/EVV13AS	Nominal	650	69.5	70.0	68.0	67.9	63.6	61.5	57.4	49.7
CRV15AS/EVV15AS	Nominal	770	72.4	71.9	68.9	71.7	66.4	63.6	60.1	52.6
CRV17AS/EVV17AS	Nominal	850	74.4	74.8	73.6	71.5	68.9	66.5	63.5	56.3
CRV13AT/EVV13AS	Nominal	650	69.5	70.0	68.0	67.9	63.6	61.5	57.4	49.7
CRV15AT/EVV15AS	Nominal	770	72.4	71.9	68.9	71.7	66.4	63.6	60.1	52.6
CRV17AT/EVV17AS	Nominal	850	74.4	74.8	73.6	71.5	68.9	66.5	63.5	56.3

NOTE:

Radiated sound power levels are based on ISO 3743-1.

SPECIFICATIONS

MODEL NUMBERS	CRV13AS/ EVV13AS	CRV15AS/ EVV15AS	CRV17AS/ EVV17AS	CRV13AT/ EVV13AS	CRV15AT/ EVV15AS	CRV17AT/ EVV17AS
INSULATION (INDOOR UNIT)						
TYPE	Foil Faced Polyethylene					
	Expanded Polystyrene					
OUTDOOR COIL						
TUBE TYPE	Copper - Rifle Bore					
FIN TYPE	Aluminium					
FACE AREA (m sqr)	1.2	1.2	1.6	1.2	1.2	1.6
COIL COATING	Hydrophilic Blue Fin Coil Coat Protection					
OUTDOOR FAN						
NUMBER OF FANS x TYPE	2 x Axial / 6 Pole External Rotor / Direct Drive					
FAN SPEED CONTROL	Variable Speed					
The factory installed outdoor fans fitted to this unit will accept up to 40 Pa of external static resistance.						
INDOOR COIL						
TUBE TYPE	Copper - Rifle Bore					
FIN TYPE	Aluminium					
FACE AREA (m sqr)	0.34	0.41	0.48	0.34	0.41	0.48
COIL COATING	Hydrophilic Blue Fin Coil Coat Protection					
INDOOR FAN						
NUMBER OF FANS x TYPE	1 x Twin Deck Centrifugal / ECM Direct Drive					
DIAMETER / WIDTH (mm)	240 x 180					
MOTOR TYPE / DRIVE TYPE	Variable Speed EC Motor / Direct					
COMPRESSOR						
NUMBER PER UNIT x TYPE	1 x Inverter Variable Speed Scroll					
STARTING METHOD	Inbuilt Soft Starting					
REFRIGERATION SYSTEM						
REFRIGERANT TYPE	R-32					
EXPANSION CONTROL	Direct Expansion Orifice /EEV			Direct Expansion Orifice /EEV		
FACTORY CHARGE (grams)	3030	3160	3790	3140	3020	3650
PRE-CHARGE LENGTH (metres)	15	15	15	15	15	15
Minimum room area (m ²)	5.811	6.321	9.092	6.241	5.773	8.433
Factory charge @2.2m release height						
ADDITIONAL REF. CHARGE (gram/metre)	40	40	40	40	40	40
FILTER DRIER						
CONNECTION SIZE AND TYPE	9.52 mm (3/8") ODF Soldered Bi-Flow					
FACTORY SUPPLIED / FITTED	No					
INTERCONNECTING PIPE RUN						
MAX. EQUIVALENT PIPE LENGTH (metres)	60					
MAX. VERTICAL HEIGHT DIFFERENTIAL (metres)	20 (Included in Max. Pipe Length)					
MAXIMUM REFRIGERATION CHARGE @ MAXIMUM PIPE LENGTH (GM)	4830	4960	5590	4940	4820	5450
/	/	/	/	/	/	/
MINIMUM ROOM AREA @ 2.2M RELEASE HEIGHT (M ²)	14.768	15.573	19.781	15.448	14.706	18.802



SPECIFICATIONS

MODEL NUMBERS	CRV13AS/ EVV13AS	CRV15AS/ EVV15AS	CRV17AS/ EVV17AS	CRV13AT/ EVV13AS	CRV15AT/ EVV15AS	CRV17AT/ EVV17AS
FIELD PIPE SIZES						
LIQUID PIPE		9.52 mm (3/8")				
GAS PIPE		19.05 mm (3/4")				
PIPE CONNECTIONS						
INDOOR	LIQUID PIPE	9.52 mm (3/8") Swaged to fit 9.52 mm (3/8") field pipe				
	GAS PIPE	19.05 mm (3/4") Swaged to fit 19.05 mm (3/4") field pipe				
OUTDOOR	LIQUID PIPE	9.52 mm (3/8") Swaged to fit 9.52 mm (3/8") field pipe				
	GAS PIPE	19.05 mm (3/4") Swaged to fit 19.05 mm (3/4") field pipe				
CONNECTION TYPE		Solder				
PROTECTION DEVICES						
HIGH PRESSURE CUTOFF SWITCH		Nonadjustable (Automatic Reset)				
COMPRESSOR MOTOR TEMP.		Internal Thermal Cut-Out				
INDOOR FAN OVERLOAD		Internal Thermal Cut-Out				
OUTDOOR FAN OVERLOAD		Internal Thermal Cut-Out				
SUMP HEATER WATTS* During Compressor Off Cycle		30 W				
*Crankcase Heater is to be disconnected for pipe lengths 8 m or less.						
ELECTRIC CONTROLS						
DEFROST METHOD		Reverse Cycle				
DEFROST TYPE		Adaptive Demand Defrost				
CONTROL FIELD WIRING		2 Core (1 Pair) Twisted Pair, 7/0.30 (0.5mm ²) Shielded Data Cable				
MASTER/SECONDARY CONTROLLER CABLE SPECS.		Cat5e UTP (AWG 24) Data Cable				
SENSOR CABLE/WIRING SPECS.		Cat5e UTP (AWG 24) Data Cable				
OPERATING RANGE						
It is essential that the unit is correctly sized for the application and operates within its recommended range of operating conditions as shown below.						
INDOOR AIR INTAKE TEMPERATURE						
COOLING MODE	MAX.	30°C DB / 22°C WB				
	MIN.	20°C DB / 16°C WB				
HEATING MODE	MAX.	24°C DB				
	MIN.	16°C DB				
OUTDOOR AIR INTAKE TEMPERATURE						
COOLING MODE	MAX.	52°C DB				
	MIN.	5°C DB				
HEATING MODE	MAX.	21°C DB / 16°C WB				
	MIN.	-10°C DB				

AIR FILTERS

All return air including fresh air must have adequate filters supplied and fitted by the installing contractor. Filters must be located in accessible location between the return air grille and the unit.

ActronAir does not supply or make any provisions for return air filter.

OUTDOOR UNIT VARIATION - DIMENSION

OUTDOOR UNIT - HORIZONTAL DISCHARGE FANS

NOTES:

Condensation points are designed to ensure all condensation is removed efficiently to avoid water pooling with the condenser. If a single condensation drain point is required, Actronair recommends the installation of a condenser tray. These are available as an additional accessory and are purchased separately.

Drawing is subject to change without notice.

CRV17AS-H / CRV17AT-H models shown for illustration purposes only.

**Air Inlet is only for CRV17AS -H/CRV17AT-H models which have coil curve .

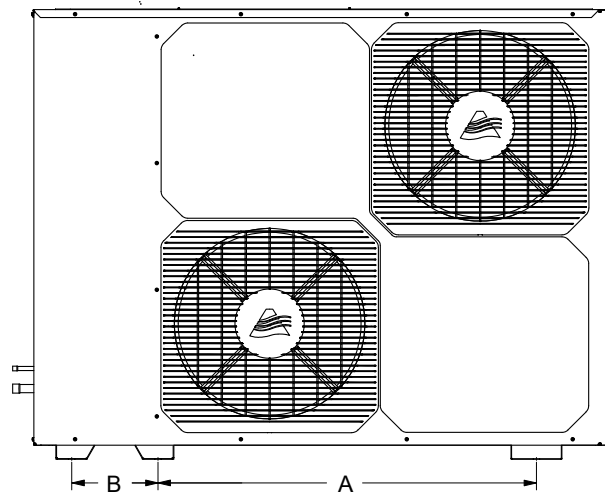
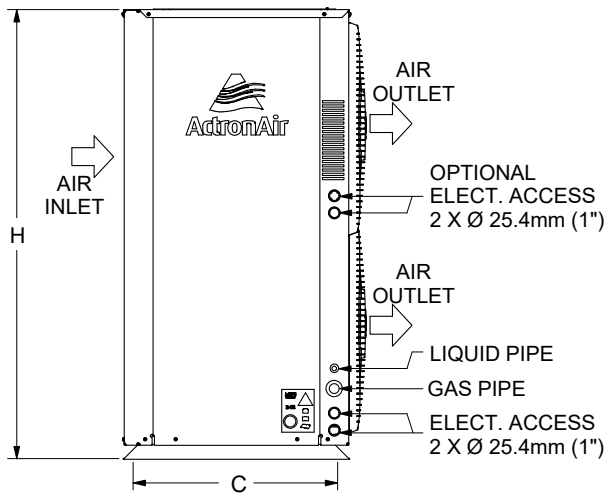
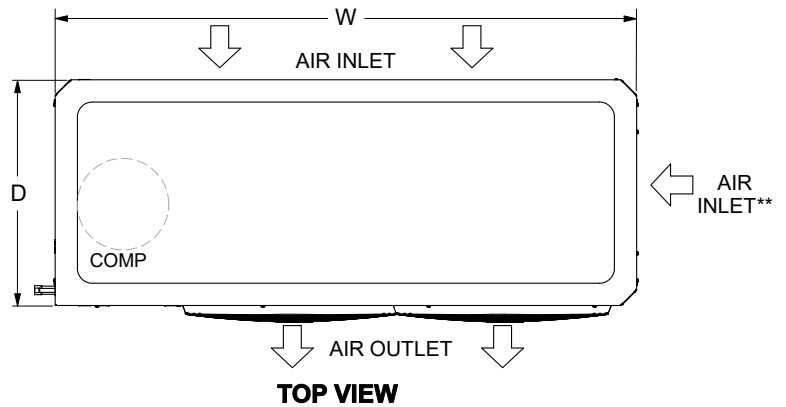

Unit Model Number	Overall Nominal Dimension (OA)			Mounting Distance Base Foot (Centre to Centre)			Gas Pipe	Liquid Pipe
	H	W	D	A	B	C		
CRV13AS-H / CRV13AT -H	1055	1365	570	887	202	480	Ø 19.05mm (3/4") Swaged	Ø 9.52 mm (3/8") Swaged
CRV15AS-H / CRV15AT-H								
CRV17AS-H / CRV17AT-H								

INDOOR UNIT VARIATION - DIMENSION

INDOOR UNIT - UPRIGHT FAN COIL WITH VERTICAL DISCHARGE

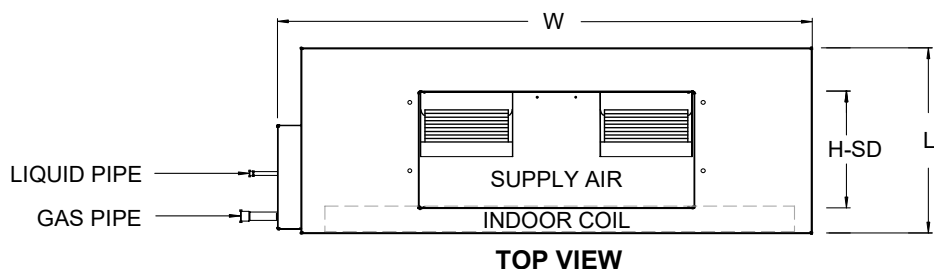

NOTES:

Drawing is subject to change without notice.
Image shown is for illustration purpose only. Actual unit may vary depending on unit model.

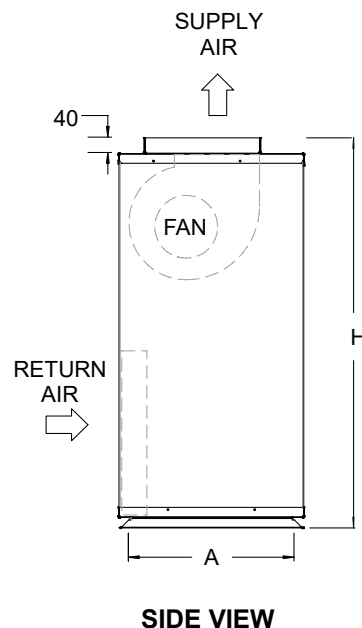
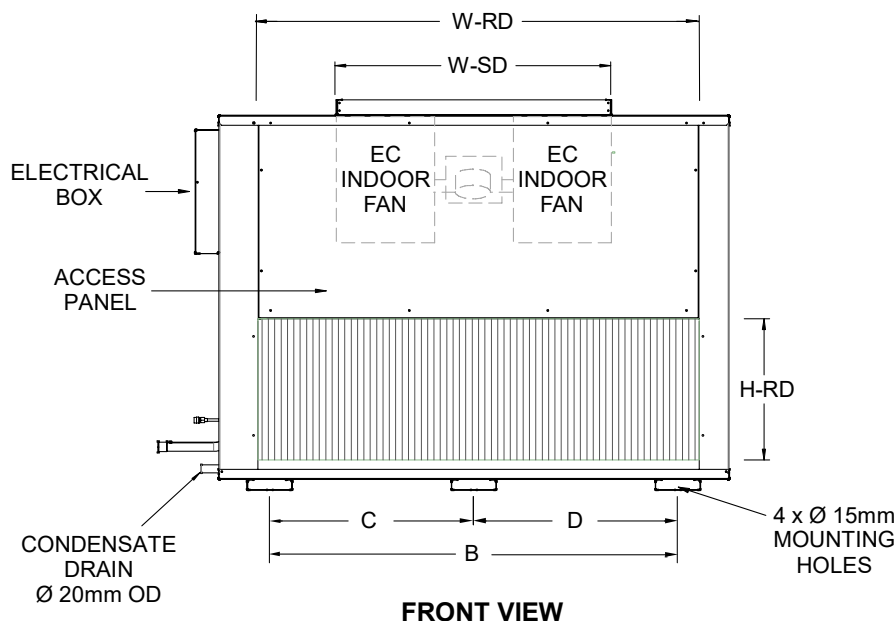

Unit Model Number	Overall Nominal Dimension (OA)			Mounting Distance Base Foot (Centre to Centre)				Supply Duct	Return Duct	Gas Pipe (Swaged)	Liquid Pipe (Swaged)
	H	W	D	A	B	C	D	H-SD x W-SD	H-RD x W-RD		
EVV13AS-V	875	1075	405	350	790	-	-	300 x 715	365 x 895	Ø 19.05mm (3/4")	Ø 9.52mm (3/8")
EVV15AS-V		1275			990	-	-				
EVV17AS-V	1015	1390	480	430	-	530	530	365 x 1095			

NOTES:

- Do not scale drawing. All dimensions are in mm unless specified. Refer to corresponding unit dimensional drawing for mounting hole details.
- Minimum service access areas and spaces for airflow clearances are responsibilities of the installer, ActronAir will not be held liable for any extra charges incurred due to lack of access and space for airflow.
- For installation with release height less than or equal to 0.6m, minimum area will be computed based on release height of 0.6m
- Where A_{min} (the minimum area required) is not satisfied, the installer must provide additional control measure/s in place as per AS/NZS 60335.2.40 standard for the installation to be acceptable.
The examples of controls measures are (but are not limited to): Ventilation, Shut Off Valves and Safety Alarm. These control measures are not provided by ActronAir and must be determined by the installer based on individual installation requirements.
- Refer to R-32 Safety Manual for minimum required area and R-32 refrigerant of the installation.

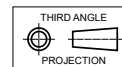

SERVICE CLEARANCES, AIRFLOW ALLOWANCES AND WEIGHTS

OUTDOOR HORIZONTAL VARIATION

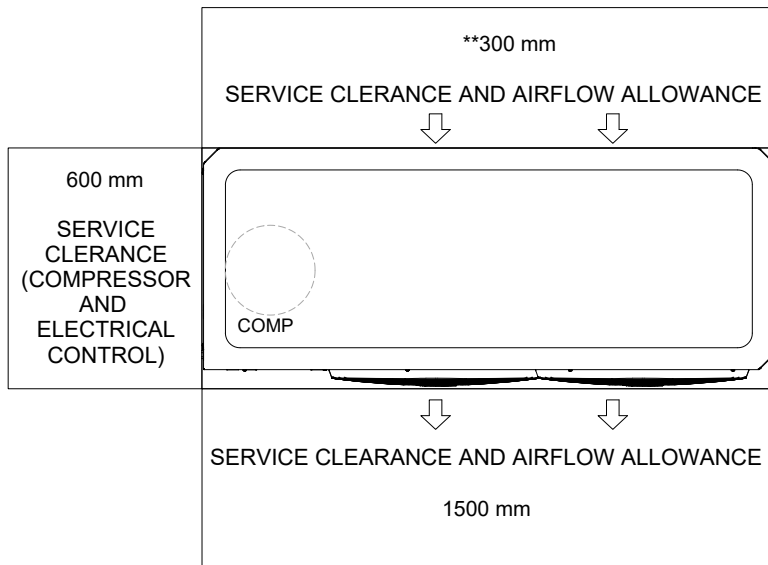

NOTES:

*Airflow Clearance is only for CRV17AS-H/CRV17AT-H models which have coil curve.
 **400 mm for CRV17AT-H and CRV17AS-H

Unit Model Number	Total Weight (Kg)
CRV13AS-H	148
CRV15AS-H	
CRV17AS-H	155
CRV13AT-H	148
CRV15AT-H	
CRV17AT-H	155

HEIGHT CLEARANCE = 300 mm

INDOOR VERTICAL VARIATION

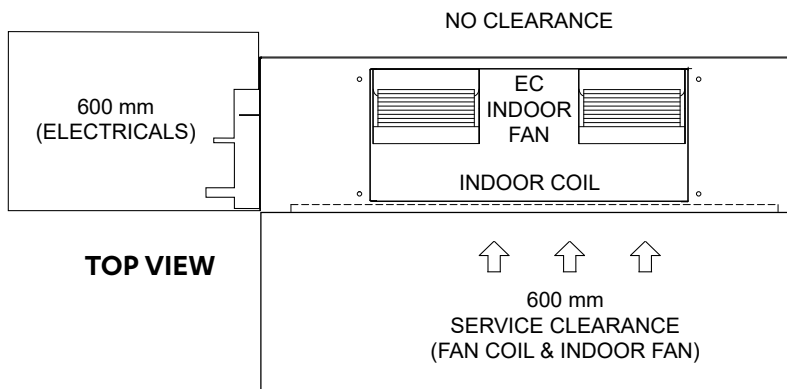

Unit Model Number	Total Weight (Kg)
EVV13AS-V	44
EVV15AS-V	53
EVV17AS-V	61

HEIGHT CLEARANCE = DUCT WORK

NOTES:

- Do not scale drawing. All dimensions are in **mm** unless otherwise specified. Refer to corresponding unit dimensional drawing for mounting hole details.
- Service Access Areas and Spaces for Airflow Clearances are suggested minimum based on the condition that the spaces around the units are free from any obstructions and a walkway passage of 1000 mm between the units or between the unit and the outside perimeter is available.
- Minimum service access areas and spaces for airflow clearances are responsibilities of the installer, ActronAir will not be held liable for any extra charges incurred due to lack of access and space for airflow.
- Under all circumstances, condenser air must not recirculate back onto condenser coil. Keep all clearance free of any obstruction.
- Refer Pipe Connection Details on Specifications Sheet.
- Use M12 bolt for feet mounting.
- For installation with release height less than or equal to 0.6m, minimum area will be computed based on release height of 0.6m.
- Where A min (the minimum area required) is not satisfied, the installer must provide additional control measure/s in place as per AS/NZS 60335.2.40 standard for the installation to be acceptable.
 The examples of controls measures are (but are not limited to): Ventilation, Shut Off Valves and Safety Alarm.
 These control measures are not provided by ActronAir and must be determined by the installer based on individual installation requirements.
- Refer to R-32 Safety Manual for minimum required area and R-32 refrigerant of the installation.

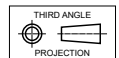

TWO-PIECE FAN COIL

Coil Section - EAA13AS / EAA15AS / EAA17AS



TOP VIEW



FRONT VIEW - SUPPLY AIR



REAR VIEW - RETURN AIR

NOTES:

Drawing is subject to change without notice. Image shown is for illustration purpose only. Actual unit may vary depending on unit model.

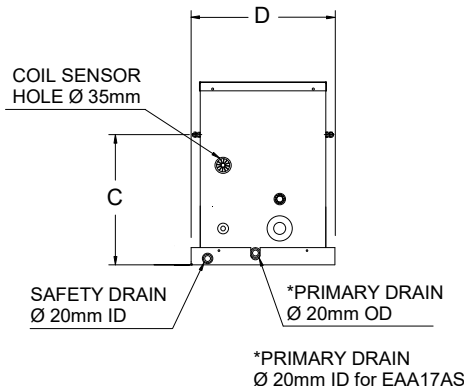

SIDE VIEW

Unit Model Number	Overall Nominal Dimension (OA)			Mounting Distance (Centre to Centre /Base Foot)			Supply Duct	Return Duct	Gas Pipe (Swaged)	Liquid Pipe (Swaged)
	H	W	D	A	B	C	H-SD x W-SD	H-RD x W-RD		
EAA13AS	410	1054	342	310	990	284	345 x 900	345 x 900	Ø 19.05mm (3/4")	Ø 9.52mm (3/8")
EAA15AS		1252			1190	283				
EAA17AS	435	1360			1294	310	362 x 1094	362 x 1094		

NOTES:

1. Do not scale drawing. All dimensions are in mm unless specified. Refer to corresponding unit dimensional drawing for mounting hole details.
2. Service Access Areas and Spaces for Airflow Clearances are suggested minimum based on the condition that the spaces around the units are free from any obstructions and a walkway passage of 1000 mm between the units or between the unit and the outside perimeter is available.
3. Minimum service access areas and spaces for airflow clearances are responsibilities of the installer, ActronAir will not be held liable for any extra charges incurred due to lack of access and space for airflow.
 - Left Service Clearance can be 100mm minimum if Right Service Clearance is applicable.
 - Right Service Clearance can be 600mm minimum if Left Service Clearance is applicable.
 - Height Service Clearance can be 100mm minimum if Right Service Clearance is applicable.
4. Installation of this unit should be in accordance with AS/NZS 60335.2.40.
5. During installation ensure that the Minimum Floor Area of the smallest room is satisfied based on the Release height, or the maximum R-32 Charge amount is not exceeded.
6. Where a minimum area is not satisfied, the installer must provide additional control measure/s such as but not limited to ventilation, shut-off valves, and safety alarm in place as per AS/NZS 60335.2.40 standard for the installation to be acceptable. These control measures are not provided by ActronAir and must be determined by the installer based on individual installation requirements.
7. Refer to R-32 Safety Manual for further safety guides.

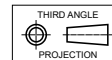

TWO-PIECE FAN COIL

Fan Section - EFV13AS / EFV15AS / EFV17AS

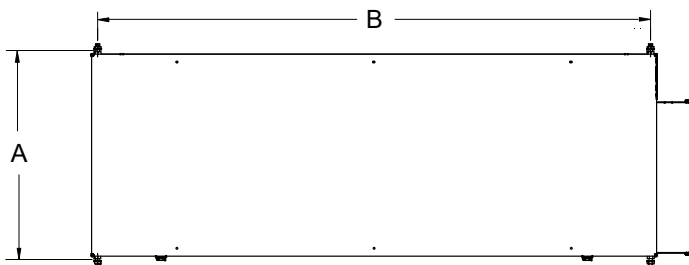

TOP VIEW

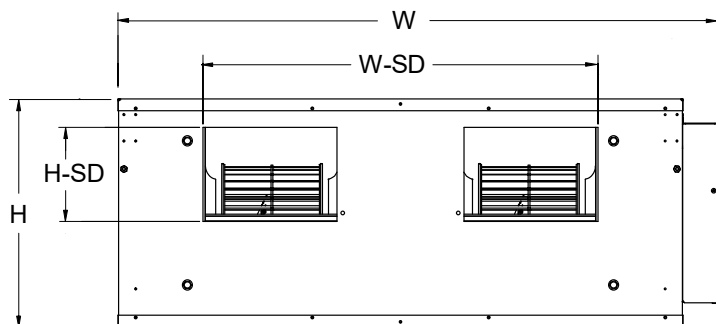

FRONT VIEW - SUPPLY AIR

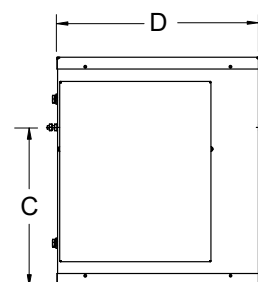

SIDE VIEW

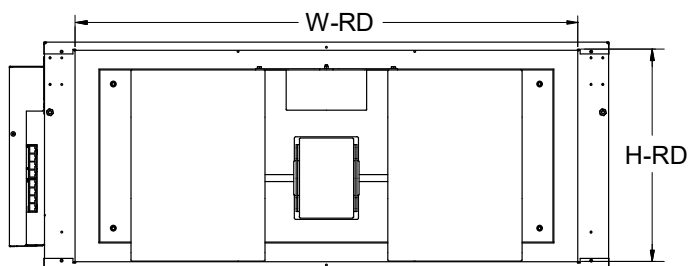

REAR VIEW - RETURN AIR

Unit Model Number	Overall Nominal Dimension (OA)			Mounting Distance (Centre to Centre / Base Foot)			Supply Duct	Return Duct
	H	W	D	A	B	C	H-SD x W-SD	H-RD x W-RD
EFV13AS	408	1072	362	370	990	282	186 x 708	378 x 900
EFV15AS								
EFV17AS								

SERVICE CLEARANCES, AIRFLOW ALLOWANCES AND WEIGHTS

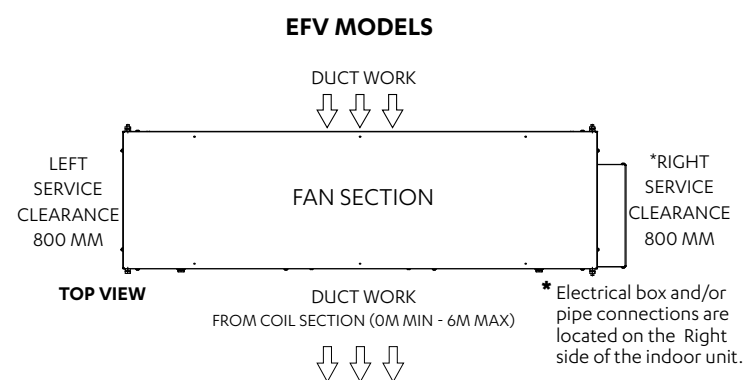
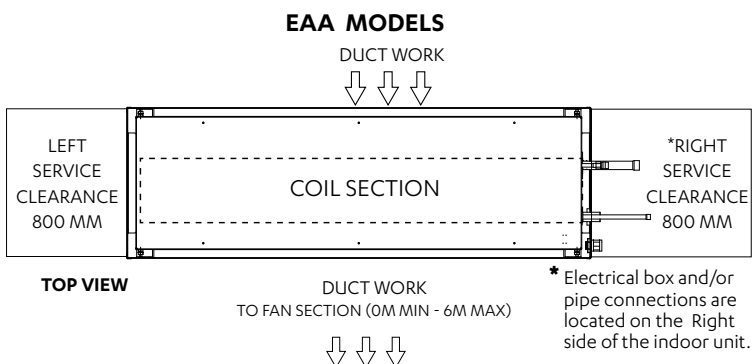

Model Number	Weight (kg)	Height Clearance
EAA13AS	28.5	340
EAA15AS	37.5	
EAA17AS	45.5	410
EFV13AS	35	340
EFV15AS	44	
EFV17AS	50.5	

NOTES:

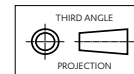

- Do not scale drawing. All dimensions are in **mm** unless otherwise specified. Refer to corresponding unit dimensional drawing for mounting hole details.
- Service Access Areas and Spaces for Airflow Clearances are suggested minimum based on the condition that the spaces around the units are free from any obstructions and a walkaway passage of 1000 mm between the units or between the unit and the outside perimeter is available.
- Minimum service access areas and spaces for airflow clearances are responsibilities of the installer, ActronAir will not be held liable for any extra charges incurred due to lack of access and space for airflow.
 - Left Service Clearance can be 100mm minimum if Right Service Clearance is applicable.
 - Right Service Clearance can be 600mm minimum if Left Service Clearance is applicable.
 - Height Service Clearance can be 100mm minimum if Right Service Clearance is applicable.
- For installation with release height less than or equal to 0.6m, minimum area will be computed based on release height of 0.6m.
- Where A min (the minimum area required) is not satisfied, the installer must provide additional control measure/s in place as per AS/NZS 60335.2.40 standard for the installation to be acceptable. The examples of controls measures are (but are not limited to): Ventilation, Shut Off Valves and Safety Alarm. These control measures are not provided by ActronAir and must be determined by the installer based on individual installation requirements.
- Refer to R-32 Safety Manual for minimum required area of installation.

ADVANCE Split Ducted Unit

Index

- Technical Selection Data (Unit and Control Features)
- Specification Summary
- Capacity Selection Data
- Three Speed Fan Curves
- Third Party Control Fan Curves
- Outdoor Unit Dimensions
- Indoor Unit Dimensions
- Indoor and Outdoor Service Clearances and Weights
- Sound Data
- Specifications
- Wiring Diagram - Single Phase
- Wiring Diagram - Three Phase
- Outdoor Unit Variation Dimensions
- Indoor Unit Variation Dimensions
- Indoor and Outdoor Variations Service Clearances and Weights
- Coil Section Unit Dimensions
- Fan Section Unit Dimensions
- Two-Piece Fan Coil Service Clearances and Weights