

VARIABLE CAPACITY COMMERCIAL INVERTER PACKAGE DUCTED UNITS PKV720T-960T

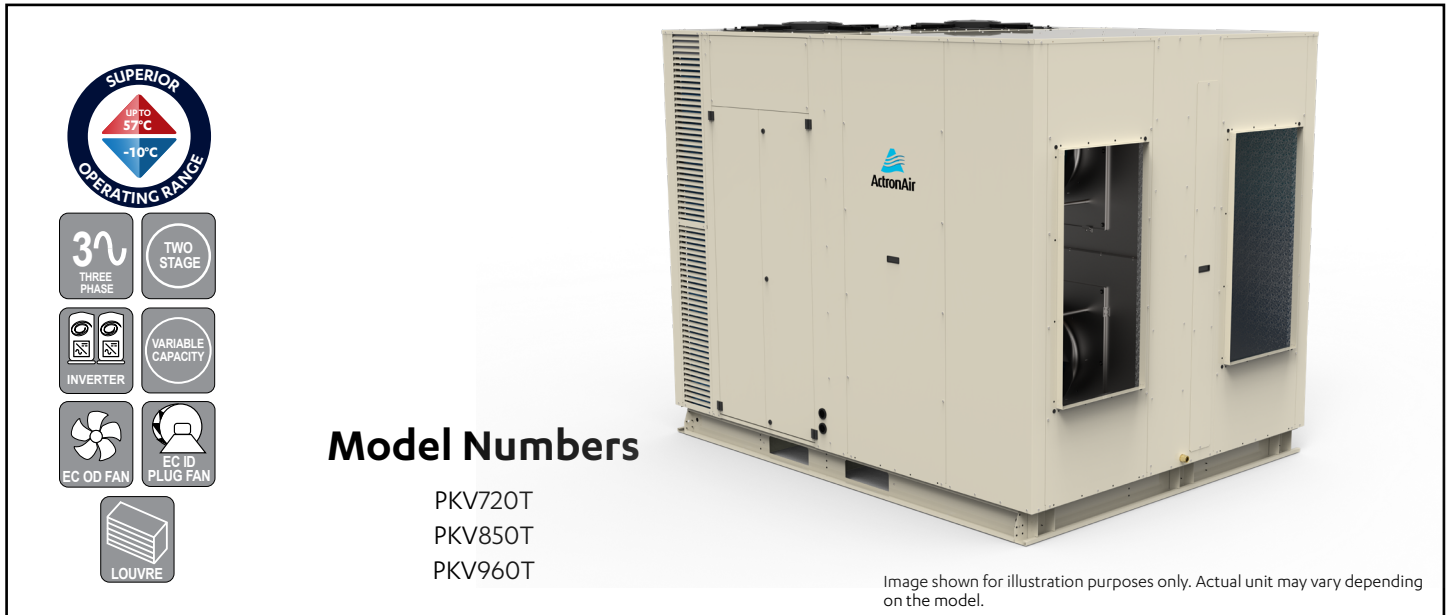

Technical Selection Data

UNIT FEATURES

- TruMax™ Inverter Variable Speed Compressor and Drive Technology
- Pre-charged with R-410A Refrigerant
- Variable Speed Outdoor Fans
- 35-100% variable refrigeration capacity
- Electronic expansion valves
- Bi-flow Low ambient cooling operation to +5°C standard
- Phase Protection
- Hydrophilic Blue Coat Coil Fin Protection - Indoor and Outdoor Coils
- Removable Louvered Outdoor Coil Guard
- Adaptive Demand Defrost
- EC Variable Speed Indoor Fan + Reduce Fan Airflow Feature
- Adjustable Indoor Airflow
- Foil Faced Polyethylene Insulation - Indoor unit
- High Static Outdoor Fans - Selectable up to 90Pa

UNIT STANDARD OPTIONS / ACCESSORIES

- Additional Full Coil Coat Protection - Indoor and Outdoor
- Economiser 3rd Party Control
- Economiser with Spill Air
- Economiser without Spill Air
- Overflow Sensor
- Weather Hood
- Demand Control with CO2
- Compressor Jacket
- Duct Sensor (AERSS)
- Wall Mount Remote Sensor (LM-RS)

UNIT COMPLIANCE

- AS/NZS 3823.2 (MEPS)
- AS/NZS 4755.3.1:2012 (DRM 1, 2 and 3)
- AS 61000.6.4 in conjunction with AS/NZS CISPR 11 (Group 1 Class A) EMC Compatibility
- AS/NZS 60335.2.40 in conjunction with AS/NZS 60335.1 (Electrical Safety - Air Conditioner)

CONTROL OPTIONS AND FEATURES

ActronAir LC7-2

- Available in White or Grey
- 7-day Programmable Controller with 2 Events per Day
- 24-hour ON/OFF Timer
- Temperature Setback
- After Hours Time
- Auto, Heat, Cool, Turbo, Fan Modes and Night Mode Functions
- Fixed, Auto and Continuous Indoor Fan Operation
- Optional 2nd and 3rd Controllers with Mimic Logic
- On-board Temperature Sensor

ActronAir NEO

- 7" Colour Touch Screen Master Controller
- In-built Wi-Fi and Blue-Tooth
- Neo Connect App
- On-Board Temperature, Humidity and Proximity Sensor
- Optional wireless Zone Sensor
- Available in White or Black

ActronAir Group Control

Third Party Control Options

- Manual and Analogue Inputs

SPECIFICATION SUMMARY

UNIT MODEL	PKV720T		PKV850T		PKV960T		
	TOTAL	NETT	TOTAL	NETT	TOTAL	NETT	
⁽³⁾ COOLING CAPACITY (kW)	RATED	73.25	71.50	86.35	84.50	98.50	96.00
	TRUMAX ⁽⁹⁾	-	78.65	-	92.96	-	105.60
	MINIMUM	-	13.10	-	15.20	-	16.20
⁽⁴⁾ HEATING CAPACITY (kW)	RATED	71.25	73.00	83.80	85.50	94.50	97.00
	TRUMAX ⁽⁹⁾	-	80.30	-	94.05	-	106.70
	MINIMUM	-	12.20	-	14.20	-	17.20
⁽³⁾ SENSIBLE CAPACITY (kW)	RATED	61.10	59.35	70.30	68.45	82.18	79.68
⁽⁵⁾ COOLING INPUT POWER (kW)	RATED	21.25		25.60		28.45	
	TRUMAX ⁽⁹⁾	24.35		30.48		35.20	
⁽⁵⁾ HEATING INPUT POWER (kW)	RATED	22.00		24.90		28.15	
	TRUMAX ⁽⁹⁾	25.90		27.03		34.76	
EER	RATED	3.45	3.36	3.38	3.30	3.46	3.37
	TRUMAX ⁽⁹⁾	-	3.23	-	3.05	-	3.00
COP	RATED	3.24	3.32	3.37	3.43	3.36	3.45
	TRUMAX ⁽⁹⁾	-	3.10	-	3.48	-	3.07
Total Cooling Seasonal Performance Factor Residential - Hot / Average / Cold		4.76 / 4.75 / 5.03		4.76 / 4.79 / 5.09		4.88 / 5.08 / 5.46	
Heating Seasonal Performance Factor Residential - Hot / Average / Cold		-		-		4.65 / 3.25 / 2.81	
⁽⁶⁾ INDOOR AIRFLOW (l/s) MIN. / NOMINAL / MAX.		1700 / 3800 / 4500		2000 / 4450 / 5350		2250 / 5000 / 6000	
⁽⁷⁾ OUTDOOR SOUND PRESS. LEVEL @ 3M dB(A) - Quiet / Rated / Tru.Max		63.6 / 70.2 / 70.2		63.7 / 69.0 / 69.0		63.7 / 69.0 / 69.0	
OUTDOOR SOUND POWER LEVEL dB(A) - Quiet / Rated / Tru.Max		80.6 / 87.2 / 87.2		80.7 / 86.0 / 86.0		80.7 / 86.0 / 86.0	
POWER SUPPLY		400V / 3Ph + N~ / 50Hz					
VOLTAGE RANGE (MIN - MAX)		376V - 424V					
IP RATING		IP44					
⁽²⁾ RATED LOAD AMPS - TOTAL		33.6		39.3		43.3	
⁽⁸⁾ FULL LOAD AMPS		53.0		65.1		75.0	
⁽¹⁰⁾ CIRCUIT BREAKER		63.0		80.0		80.0	
POWER FACTOR		0.93		0.94		0.95	
CABLE SIZE (MAIN LINE)		Refer to latest edition of AS/ANZ 3000 or AS/ANZ 3008 Australian/New Zealand Wiring Rules to determine required cable size.					
WEIGHT (kg)		TBD		1371		1478	

- (1) Based on unit rating excluding indoor fan kW.
(2) Measured and tested in accordance with AS/NZS 3823.1.2.
(3) At 27°C DB / 19°C WB entering air temperatures and 35°C ambient.
(4) At 20°C DB entering air temperature and 7°C DB / 6°C WB ambient.
(5) Total input power includes indoor fan kW.
(6) Max. - Min. airflow application range.
(7) Outdoor sound pressure level is determined in an anechoic chamber and may differ once the unit is installed due to environment conditions.
(8) Full Load Amps are based on compressor and fan motors' maximum expected current.
(9) **TRUMAX** - Maximum Capacity.
(10) See Specifications sheet for cable size and circuit breaker size details.

Notes: Use Total input power to estimate running cost.
The local electricity authority may require limits on starting current and voltage drop, please check prior to purchase.
Suggested minimum cable size should be used as a guide only, refer to the accordance with the latest edition of the AS/NZS 3000 "Australian/New Zealand Wiring Rules" for more details.

CAPACITY SELECTION DATA

PKV720T

COOLING PERFORMANCE

AIR ENTERING		TOTAL CAPACITY kW	TOTAL SENSIBLE CAPACITY - kW							
OUTDOOR DB - °C	INDOOR WB - °C		AT DB TEMPERATURE ONTO INDOOR COIL - °C							
			20	22	24	26	27	28	30	
25	16	76.66	46.59	55.51	64.18					
	17	77.39	42.18	51.00	59.87	68.01				
	18	78.24	37.47	46.41	55.38	64.18	68.23	71.88		
	19	80.21	32.68	42.04	50.79	59.68	64.09	68.21	75.45	
	20	82.05	27.76	37.22	46.16	55.09	59.56	63.96	72.17	
	21	84.41		32.33	41.69	50.55	54.94	59.34	68.08	
	22	86.58		27.54	36.93	46.15	50.32	54.76	63.63	
35	16	71.08	43.83	52.72	60.84					
	17	71.35	39.47	48.25	56.96	64.59				
	18	72.00	34.86	43.69	52.59	61.15	65.10			
	19	73.25	30.07	39.40	48.11	56.91	61.10	65.21		
	20	75.22	25.26	34.65	43.51	52.41	56.77	61.05	69.06	
	21	77.12		29.87	39.09	47.80	52.29	56.60	65.20	
	22	79.03		25.03	34.34	43.22	47.66	52.08	60.89	
45	16	63.73	40.33	49.10						
	17	63.80	35.92	44.76	53.21					
	18	64.26	31.59	40.29	49.12	57.11				
	19	64.78	26.92	35.78	44.68	53.28	57.30	60.43		
	20	66.22	22.13	31.45	40.18	48.94	53.22	57.35		
	21	67.87		26.72	35.89	44.45	48.80	53.22	61.25	
	22	69.77		21.91	31.25	39.96	44.38	48.70	57.21	
50	16	59.53	38.42	46.97						
	17	59.59	34.02	42.87	50.88					
	18	59.86	29.77	38.37	47.08					
	19	60.05	25.11	33.97	42.72	51.16	54.82			
	20	61.23	20.40	29.61	38.29	46.94	51.18	55.08		
	21	62.74		24.97	34.01	42.50	46.92	51.21	58.70	
	22	64.39		20.15	29.44	38.10	42.46	46.81	55.16	

HEATING PERFORMANCE

WB TEMP ON OUTDOOR COIL - °C	HEATING CAPACITY - kW									
	AT DB ENTERING INDOOR - °C									
	16		18		20		22		24	
	TH	IH	TH	IH	TH	IH	TH	IH	TH	IH
-10	47.70	45.79	47.47	45.57	47.21	45.32	47.01	45.13	46.78	44.91
-6	53.08	49.89	52.77	49.60	52.45	49.30	52.14	49.01	51.80	48.69
-2	59.09	52.59	58.69	52.23	58.29	51.88	57.86	51.50	57.46	51.14
2	65.55	59.65	65.07	59.21	64.56	58.75	64.04	58.28	63.53	57.81
6	72.45	72.45	71.85	71.85	71.25	71.25	70.82	70.82	70.17	70.17
10	80.48	80.48	79.77	79.77	79.03	79.03	78.29	78.29	77.52	77.52
14	89.05	89.05	88.17	88.17	87.26	87.26	86.37	86.37	85.46	85.46
18	98.19	98.19	97.17	97.17	96.14	96.14	95.12	95.12	94.01	94.01

TH - Total Heating Capacity (kW)
 IH - Integrated Heating Capacity (kW) Includes defrost losses.

AIRFLOW CORRECTION MULTIPLIER

% VARIATION	-20%	-15%	-10%	-5%	NOMINAL	5%	10%	15%	20%
INDOOR AIRFLOW (l/s)	3040	3230	3420	3610	3800	3990	4180	4370	4560
TOTAL COOLING	0.958	0.973	0.983	0.993	1.000	1.008	1.016	1.021	1.024
SENSIBLE COOLING	0.880	0.921	0.948	0.975	1.000	1.026	1.052	1.071	1.082
HEATING FACTOR	0.989	0.992	0.995	0.998	1.000	1.002	1.004	1.005	1.006

NOTES:

- No allowance has been made for the effect of indoor fan motor.
- Selection tables are based on nominal airflows. Correction factors must be applied for selection away from these conditions.



CAPACITY SELECTION DATA

PKV850T

COOLING PERFORMANCE

AIR ENTERING		TOTAL CAPACITY kW	TOTAL SENSIBLE CAPACITY - kW							
OUTDOOR DB - °C	INDOOR WB - °C		AT DB TEMPERATURE ONTO INDOOR COIL - °C							
			20	22	24	26	27	28	30	
25	16	90.38	53.57	63.86	73.85					
	17	91.24	48.48	58.65	68.88	78.27				
	18	92.25	43.05	53.36	63.71	73.86	78.53	82.74		
	19	94.57	37.52	48.31	58.41	68.66	73.75	78.50	86.85	
	20	96.75	31.84	42.76	53.07	63.37	68.53	73.60	83.07	
	21	99.54		37.12	47.91	58.13	63.20	68.27	78.35	
	22	102.10		31.59	42.42	53.06	57.87	62.99	73.22	
35	16	83.79	50.38	60.64	70.00					
	17	84.10	45.36	55.48	65.53	74.33				
	18	84.88	40.04	50.22	60.48	70.36	74.92			
	19	86.35	34.51	45.27	55.32	65.46	70.30	75.04		
	20	88.68	28.96	39.79	50.01	60.28	65.31	70.25	79.48	
	21	90.93		34.28	44.92	54.96	60.14	65.11	75.03	
	22	93.18		28.70	39.43	49.68	54.80	59.90	70.06	
45	16	75.10	46.35	56.46						
	17	75.18	41.26	51.46	61.20					
	18	75.72	36.27	46.30	56.48	65.70				
	19	76.34	30.88	41.10	51.37	61.28	65.92	69.53		
	20	78.05	25.36	36.10	46.17	56.27	61.21	65.97		
	21	79.99		30.65	41.22	51.10	56.11	61.21	70.48	
	22	82.24		25.10	35.87	45.92	51.01	56.00	65.82	
50	16	70.13	44.15	54.01						
	17	70.21	39.07	49.28	58.51					
	18	70.52	34.16	44.09	54.13					
	19	70.75	28.79	39.01	49.10	58.83	63.05			
	20	72.15	23.36	33.99	43.99	53.97	58.86	63.36		
	21	73.93		28.62	39.05	48.85	53.94	58.90	67.53	
	22	75.87		23.07	33.78	43.78	48.81	53.82	63.45	

HEATING PERFORMANCE

WB TEMP ON OUTDOOR COIL - °C	HEATING CAPACITY - kW									
	AT DB ENTERING INDOOR - °C									
	16		18		20		22		24	
	TH	IH	TH	IH	TH	IH	TH	IH	TH	IH
-10	56.21	53.96	55.94	53.71	55.64	53.42	55.41	53.19	55.14	52.94
-6	62.52	58.77	62.15	58.42	61.78	58.08	61.42	57.73	61.02	57.35
-2	69.56	61.90	69.09	61.49	68.62	61.07	68.12	60.63	67.65	60.21
2	77.13	70.19	76.56	69.67	75.96	69.12	75.36	68.58	74.76	68.03
6	85.20	85.20	84.50	84.50	83.80	83.80	83.30	83.30	82.53	82.53
10	94.61	94.61	93.77	93.77	92.91	92.91	92.04	92.04	91.14	91.14
14	104.65	104.65	103.62	103.62	102.55	102.55	101.51	101.51	100.45	100.45
18	115.36	115.36	114.16	114.16	112.96	112.96	111.76	111.76	110.45	110.45

TH - Total Heating Capacity (kW)
 IH - Integrated Heating Capacity (kW) Includes defrost losses.

AIRFLOW CORRECTION MULTIPLIER

% VARIATION	-20%	-15%	-10%	-5%	Nominal	5%	10%	15%	20%
INDOOR AIRFLOW (l/s)	3560	3783	4005	4228	4450	4673	4895	5118	5350
TOTAL COOLING	0.953	0.978	0.982	0.987	1.000	1.035	1.008	1.012	1.019
SENSIBLE COOLING	0.873	0.910	0.939	0.964	1.000	1.019	1.040	1.068	1.081
HEATING FACTOR	0.953	0.956	0.987	0.980	1.000	1.016	1.020	1.030	1.034

NOTES:

- No allowance has been made for the effect of indoor fan motor.
- Selection tables are based on nominal airflows. Correction factors must be applied for selection away from these conditions.



CAPACITY SELECTION DATA

PKV960T

COOLING PERFORMANCE

AIR ENTERING		TOTAL CAPACITY kW	TOTAL SENSIBLE CAPACITY - kW						
OUTDOOR DB - °C	INDOOR WB - °C		AT DB TEMPERATURE ONTO INDOOR COIL - °C						
			20	22	24	26	27	28	30
25	16	103.08	62.71	74.68	86.32				
	17	104.05	56.78	68.63	80.53	91.47			
	18	105.20	50.47	62.46	74.51	86.33	91.76	96.67	
	19	107.84	44.03	56.59	68.34	80.28	86.20	91.73	101.46
	20	110.31	37.42	50.12	62.13	74.11	80.12	86.03	97.05
	21	113.49		43.56	56.13	68.02	73.92	79.82	91.56
	22	116.40		37.13	49.73	62.12	67.72	73.67	85.58
35	16	95.59	59.00	70.94	81.84				
	17	95.94	53.15	64.94	76.63	86.88			
	18	96.83	46.96	58.81	70.76	82.26	87.56		
	19	98.50	40.52	53.05	64.74	76.56	82.18	87.70	
	20	101.14	34.06	46.67	58.57	70.52	76.37	82.13	92.88
	21	103.70		40.25	52.64	64.33	70.36	76.15	87.69
	22	106.26		33.75	46.25	58.19	64.14	70.08	81.91
45	16	85.72	54.30	66.07					
	17	85.81	48.38	60.25	71.60				
	18	86.42	42.57	54.25	66.10	76.83			
	19	87.13	36.30	48.19	60.15	71.68	77.08	81.29	
	20	89.07	29.86	42.37	54.09	65.86	71.61	77.15	
	21	91.27		36.03	48.34	59.83	65.67	71.61	82.39
	22	93.83		29.57	42.10	53.81	59.73	65.54	76.97
50	16	80.08	51.74	63.22					
	17	80.16	45.82	57.71	68.46				
	18	80.52	40.12	51.67	63.36				
	19	80.78	33.86	45.77	57.51	68.84	73.75		
	20	82.37	27.54	39.91	51.56	63.17	68.86	74.11	
	21	84.40		33.67	45.81	57.21	63.14	68.91	78.96
	22	86.60		27.20	39.68	51.31	57.17	63.00	74.21

HEATING PERFORMANCE

WB TEMP ON OUTDOOR COIL - °C	HEATING CAPACITY - kW									
	AT DB ENTERING INDOOR - °C									
	16		18		20		22		24	
	TH	IH	TH	IH	TH	IH	TH	IH	TH	IH
-10	63.20	60.67	62.90	60.38	62.56	60.06	62.29	59.80	61.99	59.51
-6	70.35	66.13	69.94	65.74	69.52	65.35	69.11	64.96	68.65	64.53
-2	78.34	69.72	77.81	69.25	77.28	68.78	76.71	68.27	76.18	67.80
2	86.93	79.11	86.29	78.52	85.61	77.90	84.92	77.28	84.24	76.66
6	96.09	96.09	95.29	95.29	94.50	94.50	93.93	93.93	93.06	93.06
10	106.76	106.76	105.82	105.82	104.83	104.83	103.85	103.85	102.83	102.83
14	118.15	118.15	116.98	116.98	115.77	115.77	114.60	114.60	113.39	113.39
18	130.30	130.30	128.94	128.94	127.58	127.58	126.22	126.22	124.74	124.74

TH - Total Heating Capacity (kW)
IH - Integrated Heating Capacity (kW) Includes defrost losses.

AIRFLOW CORRECTION MULTIPLIER

% VARIATION	-20%	-15%	-10%	-5%	Nominal	5%	10%	15%	20%
INDOOR AIRFLOW (l/s)	4000	4250	4500	4750	5000	5250	5500	5750	6000
TOTAL COOLING	0.965	0.982	0.989	0.997	1.000	1.004	1.009	1.015	1.020
SENSIBLE COOLING	0.884	0.916	0.945	0.974	1.000	1.024	1.046	1.072	1.092
HEATING FACTOR	0.969	0.976	0.983	0.991	1.000	1.011	1.022	1.033	1.044

NOTES:

- No allowance has been made for the effect of indoor fan motor.
- Selection tables are based on nominal airflows. Correction factors must be applied for selection away from these conditions.



INDOOR FAN DATA

PKV720T

FAN DATA																					
AIRFLOW (l/s)		EXTERNAL STATIC PRESSURE (Pa)																			
		50		100		150		200		250		300		350		400		450		500	
		% SPD	W	% SPD	W	% SPD	W	% SPD	W	% SPD	W	% SPD	W	% SPD	W	% SPD	W	% SPD	W	% SPD	W
1*	1000	32	350	39	211	47	365	53	456	58	607	64	716	68	900	72	1068	76	1160	78	1360
	1500	41	413	47	421	53	568	58	709	63	873	67	1028	71	1202	75	1390	78	1542	82	1749
2*	1700	45	439	50	510	56	654	61	815	65	985	69	1160	73	1329	77	1525	80	1702	84	1912
	2000	50	475	55	631	59	772	64	961	68	1139	72	1341	75	1504	79	1712	83	1924	87	2137
	2500	60	756	64	932	68	1139	71	1302	75	1523	78	1695	82	1927	85	2105	88	2332	91	2560
	3000	70	1145	73	1343	76	1534	79	1709	83	1979	86	2199	89	2434	92	2682	96	3022	98	3189
3*	3500	79	1545	82	1780	85	2016	88	2281	91	2558	94	2856	96	3055	98	3253	MOTOR /BLOWER LIMIT			
	3800	85.6	1969	88	2189	91	2472	93	2704	96	2940	98	3184								
	4000	90	2251	92	2461	95	2776	97	2985	99	3195										
	4500	99	2854																		

- * 1 Airflow during compressor OFF operation.
- 2 Airflow during Safe Mode, see the fan curve for detailed information.
- 3 Capacity Selection Range - See the Airflow Correction Multiplier for details.

NOTES:

% Speed = Indoor Fan Speed Control Setting, in percent

W = Indoor Fan Power, Watts

 Bold data in the box indicates Factory Default Setting.

High speed limit may be outside the fan curves at lower static condition which needs to be taken care while operating the unit.

	Indoor Fan % SPD Limits
High Spd. Limit (%)	99
Low Spd. Limit (%)	32

FAN DATA																				
AIRFLOW (l/s)		EXTERNAL STATIC PRESSURE (Pa)																		
		100		150		200		250		300		350		400		450		500		
		% SPD	W	% SPD	W	% SPD	W	% SPD	W	% SPD	W	% SPD	W	% SPD	W	% SPD	W	% SPD	W	
1*	1200	38	258	44	425	49	516	55	736	60	903	65	1160	69	1361	73	1589	76	1687	
	1500	39	309	45	481	51	645	56	813	61	997	66	1272	70	1485	74	1722	77	1826	
2*	2000	43	480	48	660	54	843	59	1038	64	1236	68	1498	73	1870	76	2019	79	2103	
	2500	47	616	53	851	58	1081	62	1258	67	1574	71	1844	75	2153	78	2328	81	2543	
	3000	53	831	58.1	1092	62	1316	66	1562	70	1836	74	2152	77	2404	80	2613	84	3012	
	3500	58	1040	62	1285	66	1547	70	1841	74	2186	77	2457	80	2738	83	3039	87	3438	
3*	4000	64	1332	68	1634	71	1880	74	2166	78	2541	81	2844	84	3183	87	3527	91	4020	
	4450	69	1615	72	1907	76	2275	79	2550	82	2922	85	3271	87	3531	90	3925	94	4429	
	4500	70	1680	73	1974	76	2275	79	2593	82	2922	85	3271	88	3658	91	4068	95	4540	
	5000	75	2027	78	2350	81	2706	84	3078	87	3465	89	3750	92	4177	95	4634	98	5029	
	5350	79	2291	82	2655	85	3079	88	3496	90	3811	93	4343	96	4732	98	5042			

* 1 Airflow during compressor OFF operation.

2 Airflow during Safe Mode, see the fan curve for detailed information.

3 Capacity Selection Range - See the Airflow Correction Multiplier for details.

NOTES:

% Speed = Indoor Fan Speed Control Setting, in percent

W = Indoor Fan Power, Watts

 Bold data in the box indicates Factory Default Setting.

High speed limit may be outside the fan curves at lower static condition which needs to be taken care while operating the unit.

	Indoor Fan % SPD Limits
High Spd. Limit (%)	99
Low Spd. Limit (%)	38

INDOOR FAN DATA

PKV960T

FAN DATA																			
AIRFLOW (l/s)		EXTERNAL STATIC PRESSURE (Pa)																	
		100		150		200		250		300		350		400		450		500	
		% SPD	W	% SPD	W	% SPD	W	% SPD	W	% SPD	W	% SPD	W	% SPD	W	% SPD	W	% SPD	W
1*	1250	40	390	45	501	51	651	56	816	60	904	65	1181	69	1399	73	1686	76	1774
	1500	41	439	46	551	52	752	57	924	61	1005	66	1306	70	1540	74	1837	77	1947
	2000	44	536	49	700	54	887	59	1069	64	1308	68	1554	72	1823	76	2140	79	2293
2*	2500	48	671	53	882	58	1113	62	1296	67	1611	71	1909	75	2248	78	2443	81	2637
	3000	53	859	57	1064	62	1339	66	1603	70	1913	74	2228	77	2471	80	2745	83	2980
	3500	58	1069	62	1316	66	1590	70	1911	73	2166	77	2526	80	2805	83	3136	87	3614
	4000	64	1367	67	1618	71	1953	74	2227	77	2519	81	2925	84	3256	87	3659	90	4053
3*	4500	69	1682	73	2035	76	2343	79	2663	82	3013	85	3370	88	3772	91	4203	93	4527
	5000	75	2090	78	2445	81	2797	84	3182	86	3455	89	3873	92	4323	95	4800	98	5320
	5500	80	2530	83	2932	86	3337	89	3753	91	4064	94	4573	96	4917	98	5310		
	6000	86	3180	89	3623	92	4034	94	4360	97	4969	99	5382	MOTOR /BLOWER LIMIT					

* 1 Airflow during compressor OFF operation.

2 Airflow during Safe Mode, see the fan curve for detailed information.

3 Capacity Selection Range - See the Airflow Correction Multiplier for details.

NOTES:

% Speed = Indoor Fan Speed Control Setting, in percent

W = Indoor Fan Power, Watts

 Bold data in the box indicates Factory Default Setting.

High speed limit may be outside the fan curves at lower static condition which needs to be taken care while operating the unit.

	Indoor Fan % SPD Limits
High Spd. Limit (%)	99
Low Spd. Limit (%)	40

INDOOR FAN CURVE

PKV720T

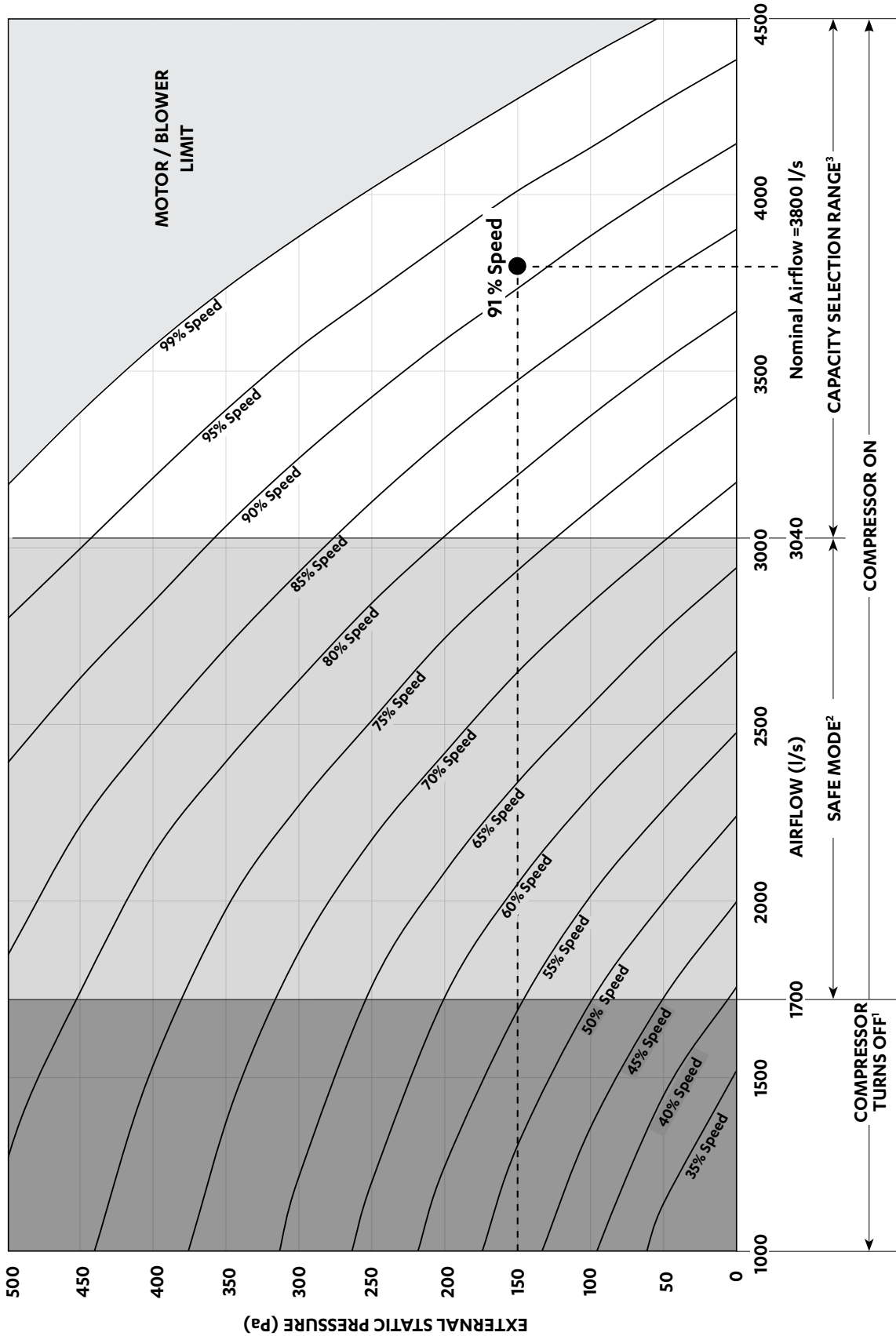

NOTE

1 When the airflow goes below the lower limit of the Safe Mode, the compressor turns off, the fan will continue to run.
 2 System safety logic may be activated
 Fan Performance Data and Fan Curve shown is at dry coil and with no air filters installed. Consider external static pressure drop specific to your design requirements. Airflow should be reduce with respect to the moisture content in the air. Please review filter manufacturer for application. 2.5 m/s face velocity point will occur outside the application range.



INDOOR FAN CURVE

PKV850T

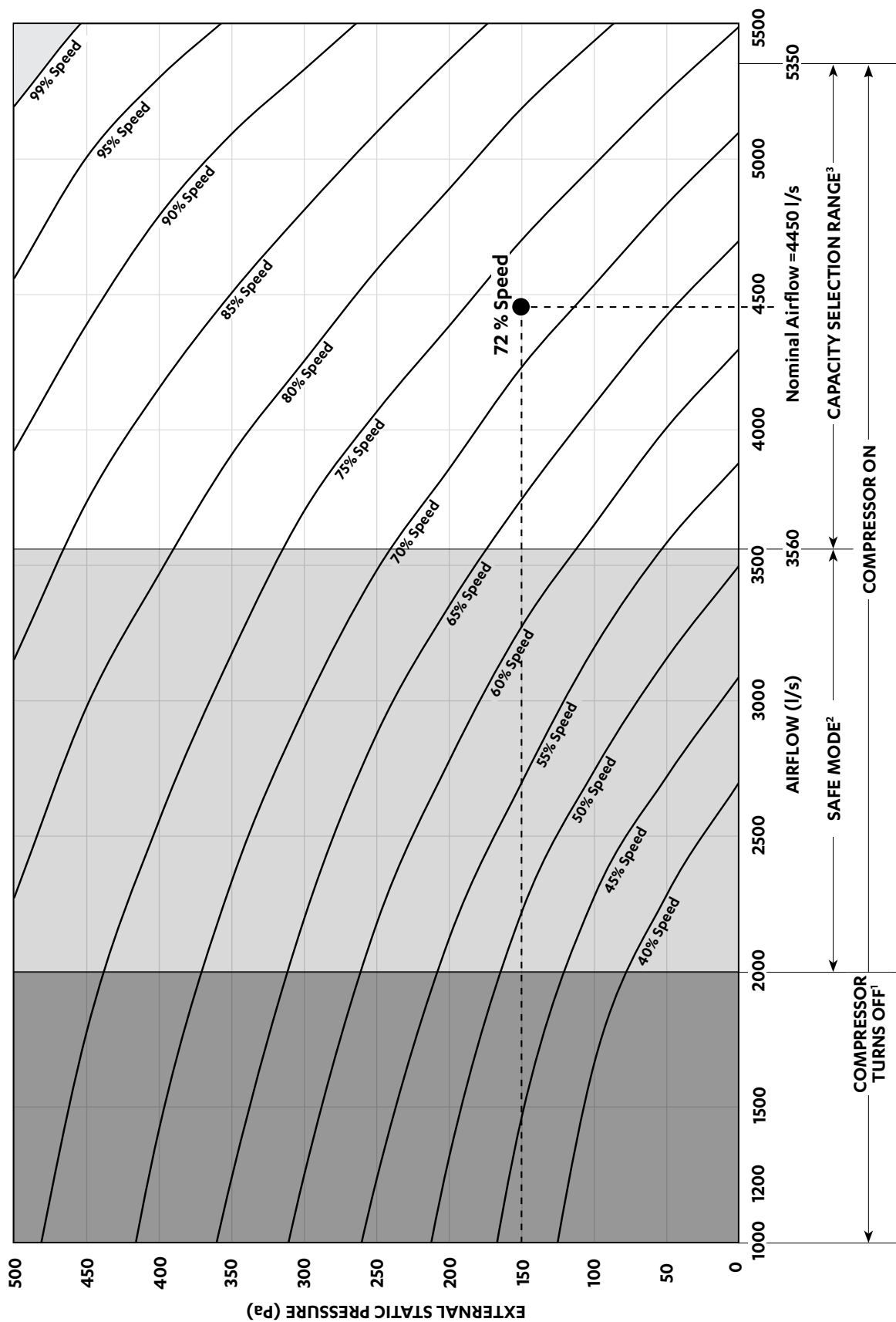

NOTE

- 1 When the airflow goes below the lower limit of the Safe Mode, the compressor turns off; the fan will continue to run.
 - 2 System safety logic may be activated
- Fan Performance Data and Fan Curve shown is at dry coil and with no air filters installed. Consider external static pressure drop specific to your design requirements. Airflow should be reduced with respect to the moisture content in the air. Please review filter manufacturer for application. 2.5 m/s face velocity point will occur outside the application range.



INDOOR FAN CURVE

PKV960T

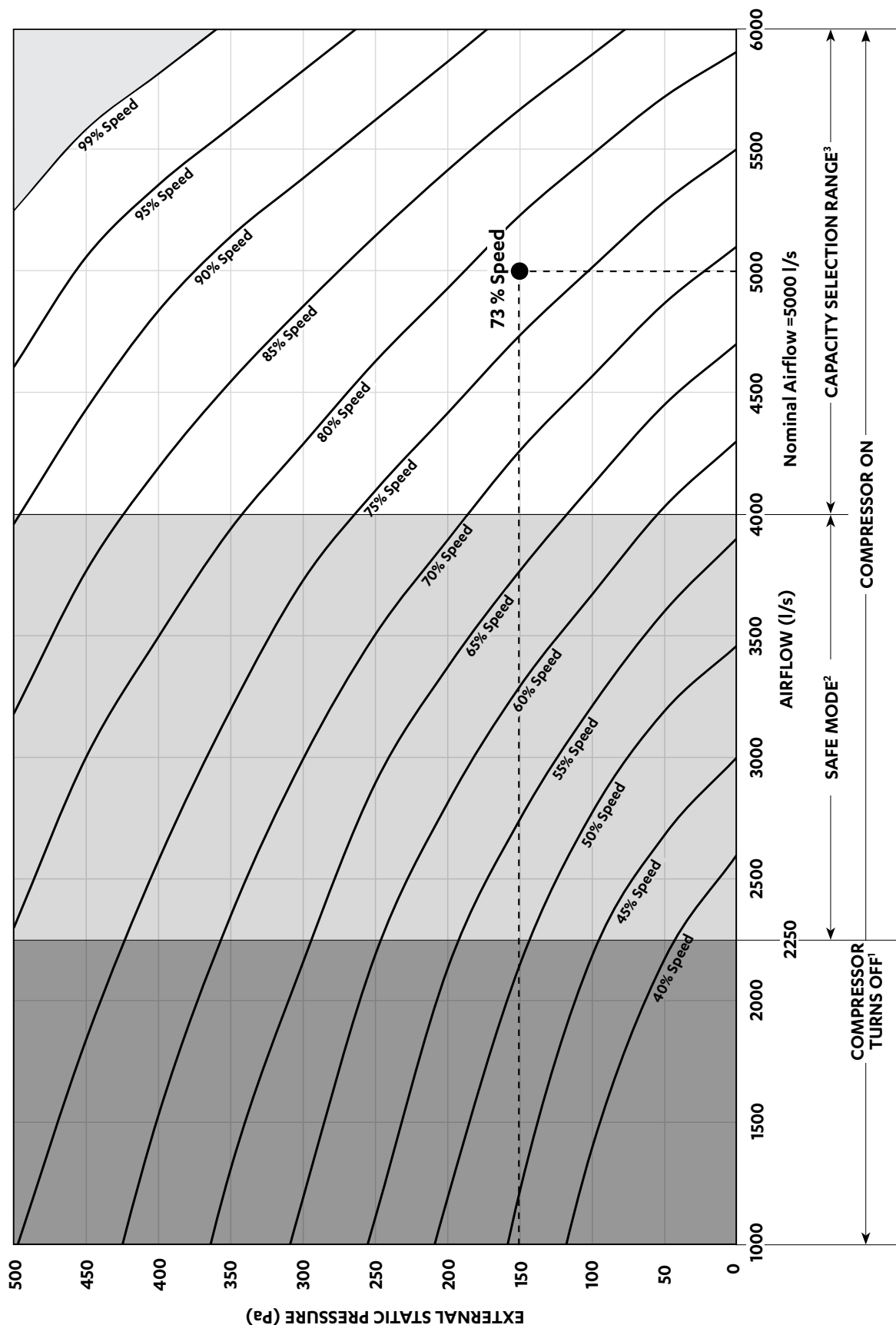

NOTE

- 1 When the airflow goes below the lower limit of the Safe Mode, the compressor turns off; the fan will continue to run.
 - 2 System safety logic may be activated
- Fan Performance Data and Fan Curve shown is at dry coil and with no air filters installed. Consider external static pressure drop specific to your design requirements. Airflow should be reduced with respect to the moisture content in the air. Please review filter manufacturer for application. 2.5 m/s face velocity point will occur outside the application range.



UNIT DIMENSIONS

PKV720T

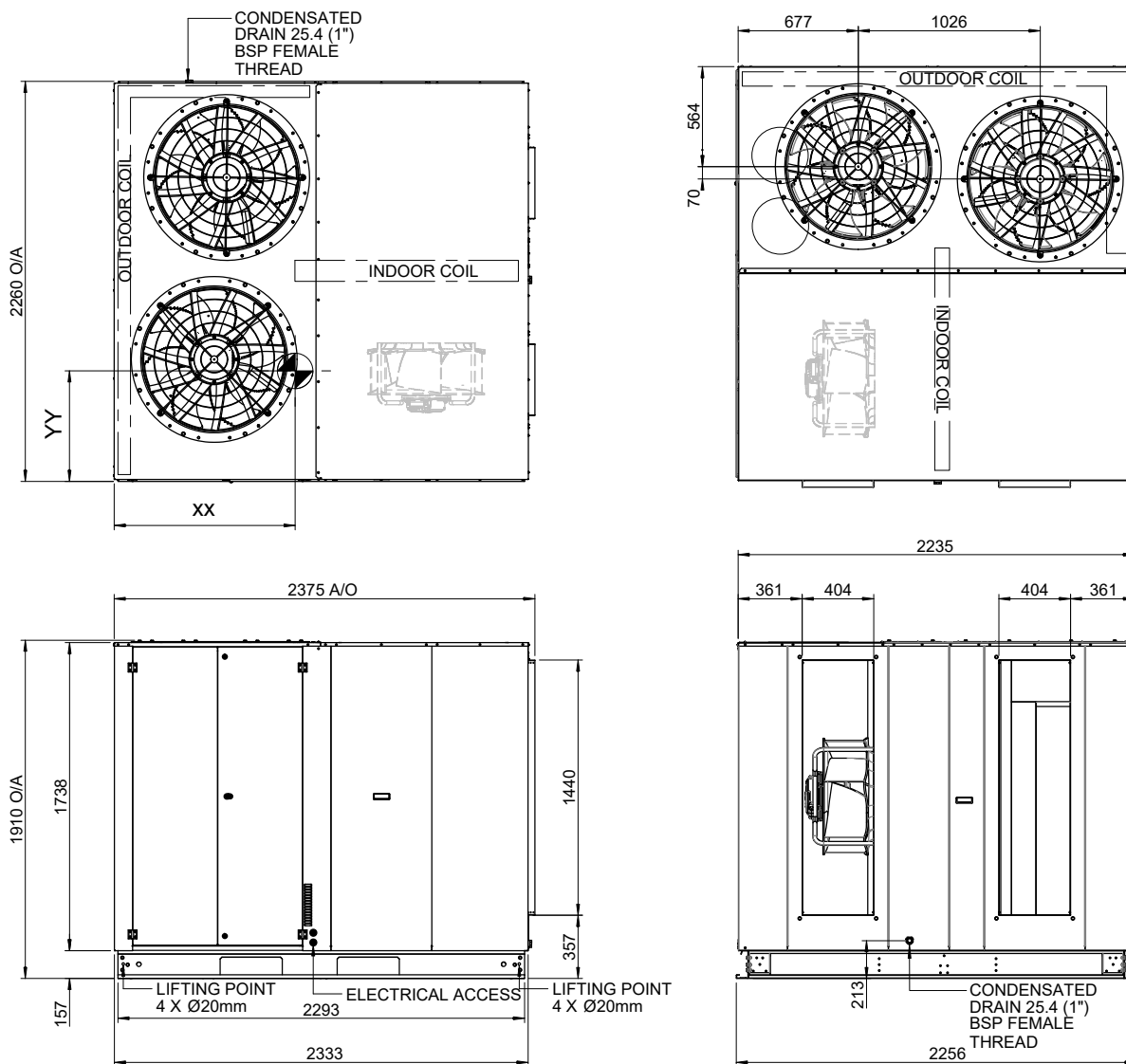

Unit Weight (kg)	Mounting Point Weights (kg)				Centre of Gravity Position	
	A	B	C	D	XX	YY
TBD	TBD	TBD	TBD	TBD	TBD	TBD

NOTES:

1. Do not scale drawing. All dimensions are in mm unless otherwise specified. Refer to corresponding unit dimensional drawing for mounting hole details.
2. MTG C-C DIST = Mounting Centre to Centre Distance.
3. Diagrams are left handing (LFFT).
4. For right handing units, layout of above are mirrored.
 - The Supply and Return Air
 - Coil and Filter Access

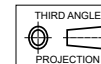

UNIT DIMENSIONS

PKV850T / PKV960T

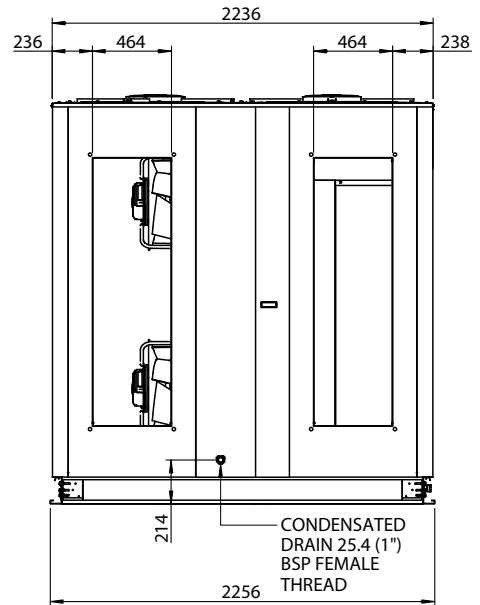
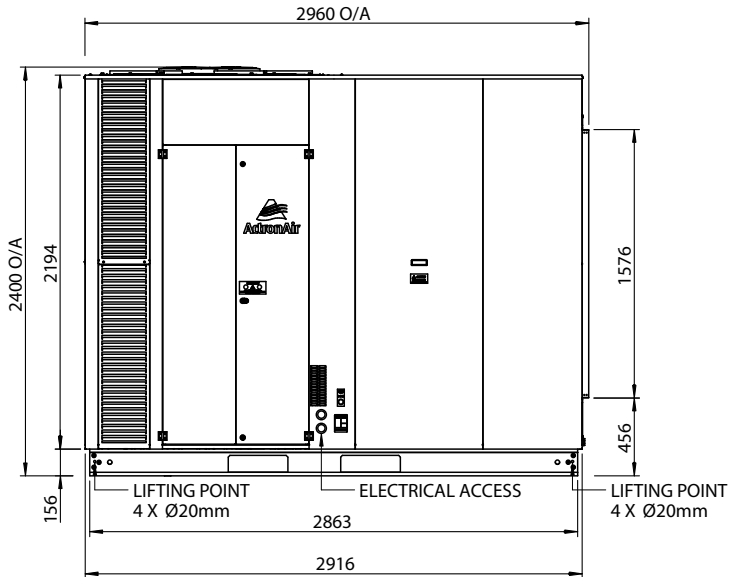
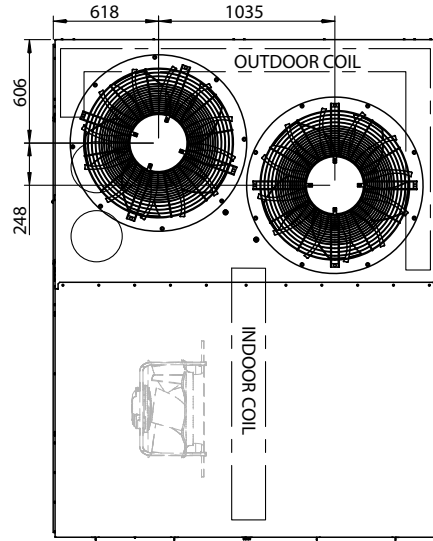
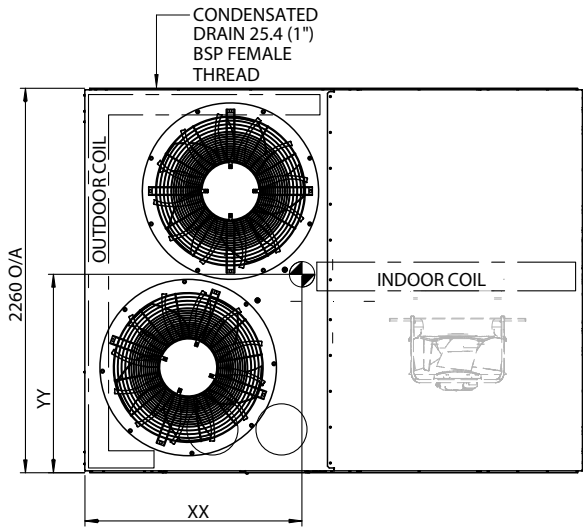

	Unit Weight (kg)	Corner Weights (kg)				Centre of Gravity Position	
		A	B	C	D	XX	YY
PKV850T	1371	405	355	182	429	1319	1143
PKV960T	1478	387	440	290	361	1271	1162

NOTES:

- Do not scale drawing. All dimensions are in mm unless otherwise specified. Refer to corresponding unit dimensional drawing for mounting hole details.
- MTG C-C DIST = Mounting Centre to Centre Distance.
- Diagrams are left handing (LFFT).
- For right handing units, layout of above are mirrored.
 - The Supply and Return Air
 - Coil and Filter Access

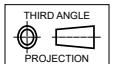

ACCESS AREAS / BASE MOUNT

SERVICE ACCESS AREAS AND AIRFLOW CLEARANCES

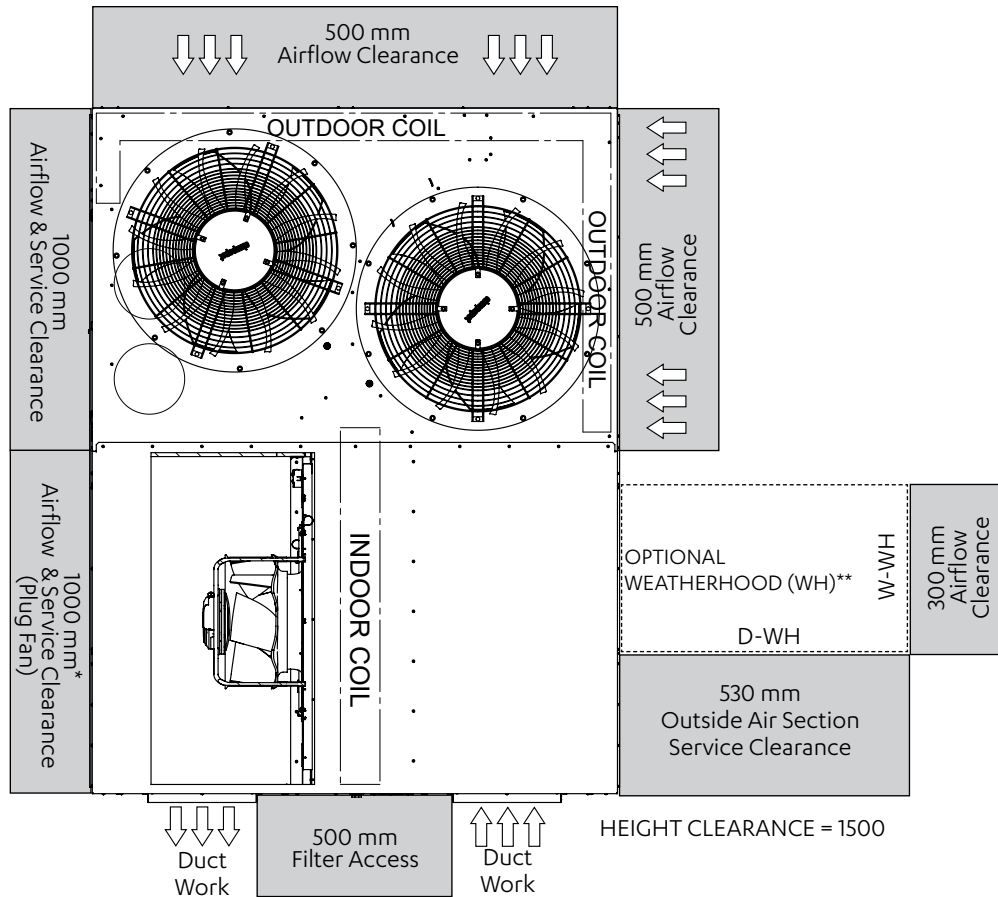

Model Numbers	Weatherhood Dimensions	
	D-WH	W-WH
PKV720T	1200	465
PKV850T	1100	660
PKV960T		

NOTES:

1. * For reverse handing, service clearance for plug fan and airflow clearance for hood will be reversed.
2. ** If the optional hood is not installed, 500 mm clearance is required for service access.
3. Service Access Areas and Spaces for Airflow Clearances are suggested minimum based on the condition that the spaces around the units are free from any obstructions and a walkaway passage of 1000 mm between the units or between the unit and the outside perimeter is available.
4. Minimum service access areas and spaces for airflow clearances are responsibilities of the installer, ActronAir will not be held liable for any extra charges incurred due to lack of access and space for airflow.
5. Under all circumstances, condenser air must not recirculate back onto condenser coil. Keep all clearance free of any obstruction.
6. STACKING OF UNITS: Ensure that minimum airflow and clearances are met.
7. Diagrams are left handing.

ACCESS AREAS / BASE MOUNT

UNIT BASE DIMENSIONS

Down discharge/down return option shown below

PKV720T

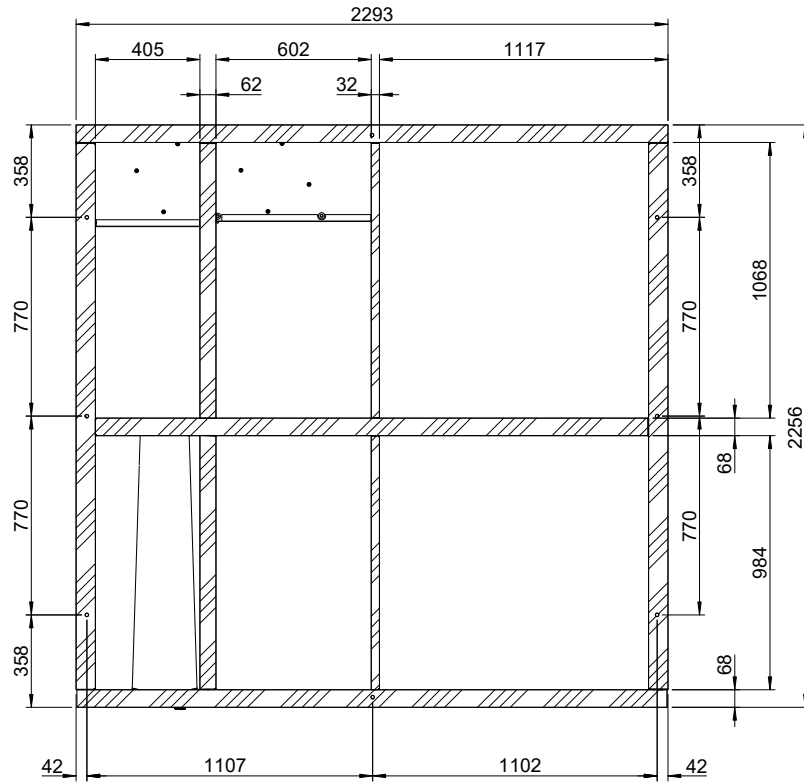

NOTES:

Use M12 bolt for feet mounting.

PKV850T / PKV960T

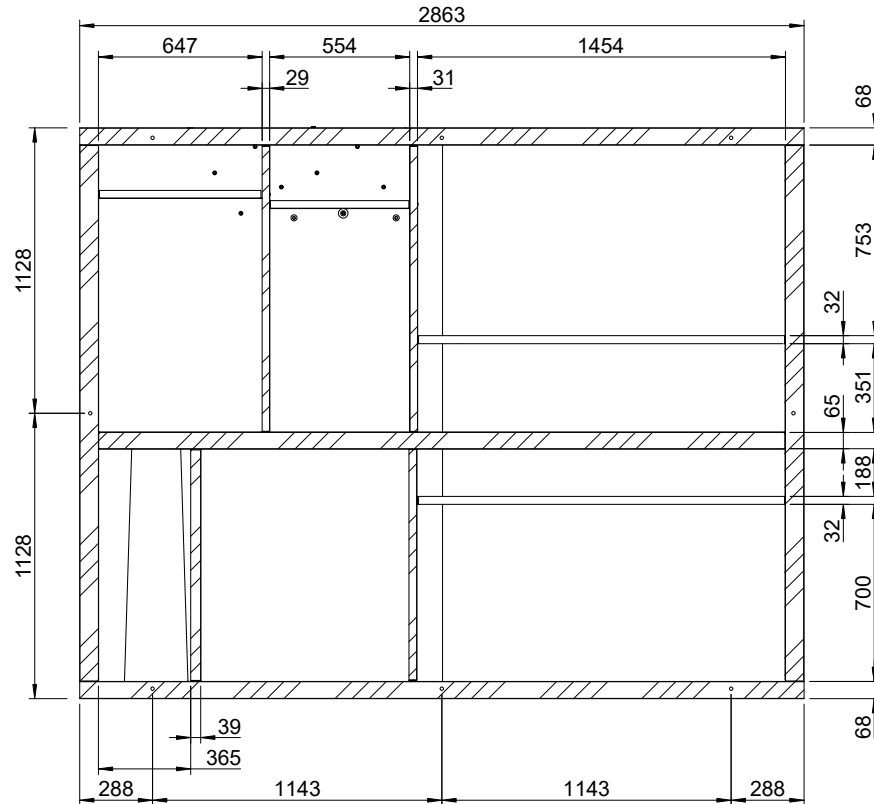

SOUND DATA

OUTDOOR RADIATED

Sound Power Level (SWL)

Model Number		Sound Power Level dB(A)	Sound Pressure Level dB(A)	Octave Band Centre Frequency (Hz), dB							
				63	125	250	500	1k	2k	4k	8k
PKV720T	Tru.Max	87.2	70.2	98.7	97.6	87.1	84.1	79.7	76.7	71.5	64.5
	Rated	87.2	70.2	98.7	97.6	87.1	84.1	79.7	76.7	71.5	64.5
	Quiet	80.6	63.6	84.3	82.2	81.4	77.2	76.2	71.7	65.3	59.1
PKV850T	Tru.Max	86.0	69.0	89.5	91.4	85.2	80.9	81.7	78.2	72.5	67.0
	Rated	86.0	69.0	89.5	91.4	85.2	80.9	81.7	78.2	72.5	67.0
	Quiet	80.7	63.7	88.0	81.4	78.8	75.8	75.8	74.2	65.3	62.8
PKV960T	Tru.Max	86.0	69.0	89.5	91.4	85.2	80.9	81.7	78.2	72.5	67.0
	Rated	86.0	69.0	89.5	91.4	85.2	80.9	81.7	78.2	72.5	67.0
	Quiet	80.7	63.7	88.0	81.4	78.8	75.8	75.8	74.2	65.3	62.8

INDOOR OUTLET

Sound Power Level (SWL)

Model Number	Airflow Setting	Airflow l/s	Sound Power Level dB(A)	Octave Band Centre Frequency (Hz), dB							
				63	125	250	500	1k	2k	4k	8k
PKV720T	Nominal	3750	80.0	80.1	85.7	82.7	79.0	72.0	66.9	66.3	55.9
PKV850T	Nominal	4450	78.2	77.8	84.1	78.6	76.9	71.7	68.2	62.4	52.8
PKV960T	Nominal	5000	80.1	77.7	86.6	80.4	78.9	73.5	70.0	64.1	54.5

NOTE:

Radiated sound power levels are based on ISO 3743-1.

SPECIFICATIONS

MODEL NUMBERS	PKV720T	PKV850T	PKV960T
CONSTRUCTION			
CABINET BASE	1.6 - 2.4 mm Galvanised Steel		
CABINET TOP AND SIDES	0.9 - 1.6 mm Galvanised Steel		
SURFACE FINISH	60 - 80 μ Baked Polyester Powder Coat		
INSULATION (INDOOR UNIT)			
TYPE	Foil Faced Polyethylene		
OUTDOOR COIL			
TUBE TYPE	Copper - Rifle Bore Enhanced		
FIN TYPE	Aluminum Lanced Straight Edge	Aluminum Straight Slit	
COIL COATING	Hydrophilic Blue Fin Coil Coat		
OUTDOOR FAN			
NUMBER OF FANS x TYPE	2 x Axial / Direct Drive		
FAN SPEED CONTROL	Variable Speed		
The factory installed outdoor fans fitted to this unit will accept up to 90 Pa of external static resistance.			
INDOOR COIL			
TUBE TYPE	Aluminum - Rifle Bore Enhanced		
FIN TYPE	Aluminium Hydro Coating		
COIL COATING	Hydrophilic Blue Fin Coat		
INDOOR FAN			
NUMBER OF FANS x TYPE	1 x EC Fan	2 x EC Fan	
DIAMETER (mm)	630	570	
MOTOR TYPE / DRIVE TYPE	Variable Speed ECM / Direct Drive Backward Curve Plug Fan		
COMPRESSOR			
NUMBER PER UNIT x TYPE	2 x Inverter Variable Speed Scroll		
STARTING METHOD	Inbuilt Soft Starting		
REFRIGERATION SYSTEM			
REFRIGERANT TYPE	R-410A		
NO. OF REFRIGERATION CIRCUITS	2		
NO. CAPACITY STAGES	Variable Capacity		
EXPANSION CONTROL	Direct Expansion Orifice /EEV		
FACTORY CHARGE (grams)	12,900 and 12,900	12,830 and 13,330	16,900 and 17,200
PROTECTION DEVICES			
HIGH PRESSURE CUTOFF SWITCH	Nonadjustable (Automatic Reset)		
COMPRESSOR MOTOR TEMP.	Internal Thermal Cut-Out		
INDOOR FAN OVERLOAD	Internal Thermal Cut-Out		
OUTDOOR FAN OVERLOAD	Internal Thermal Cut-Out		
SUMP HEATER WATTS During Compressor Off Cycle	50 W		

SPECIFICATIONS

MODEL NUMBERS	PKV720T	PKV850T	PKV960T	
ELECTRIC CONTROLS				
DEFROST METHOD	Reverse Cycle			
DEFROST TYPE	Adaptive Demand Defrost			
CONTROL FIELD WIRING	2 Core 14 / 0.20 Screened Cable			
MASTER/SECONDARY CONTROLLER CABLE SPECS.	Cat5e with RJ45 Connectors and cable boots			
SENSOR CABLE/WIRING SPECS.	Cat5e UTP (AWG 24) Data Cable			
OPERATING RANGE				
It is essential that the unit is correctly sized for the application and operates within its recommended range of operating conditions as shown below.				
INDOOR AIR INTAKE TEMPERATURE				
COOLING MODE	MAX.	30°C DB / 22°C WB		
	MIN.	20°C DB / 16°C WB		
HEATING MODE	MAX.	24°C DB		
	MIN.	16°C DB		
OUTDOOR AIR INTAKE TEMPERATURE				
COOLING MODE	MAX.	54°C DB	56°C DB	57°C DB
	MIN.	5°C DB		
HEATING MODE	MAX.	19.5°C DB / 18°C WB		
	MIN.	-10°C DB		
AIR FILTERS				
All return air including fresh air must have adequate filters supplied and fitted by the installing contractor. Filters must be located in accessible location between the return air grille and the unit.				
ActronAir does not supply or make any provisions for return air filter. Filter Rails are fitted but Filters are not supplied.				
MODEL NUMBERS	PKV720T	PKV850T	PKV960T	
FILTER SIZE (INCHES)	20" x 20" x 4"	24" x 24" x 4"	24" x 24" x 4"	
QUANTITY	6	6	6	

Note: Supplier filter may be different by a few millimeters.

WIRING DIAGRAM - PKV720T

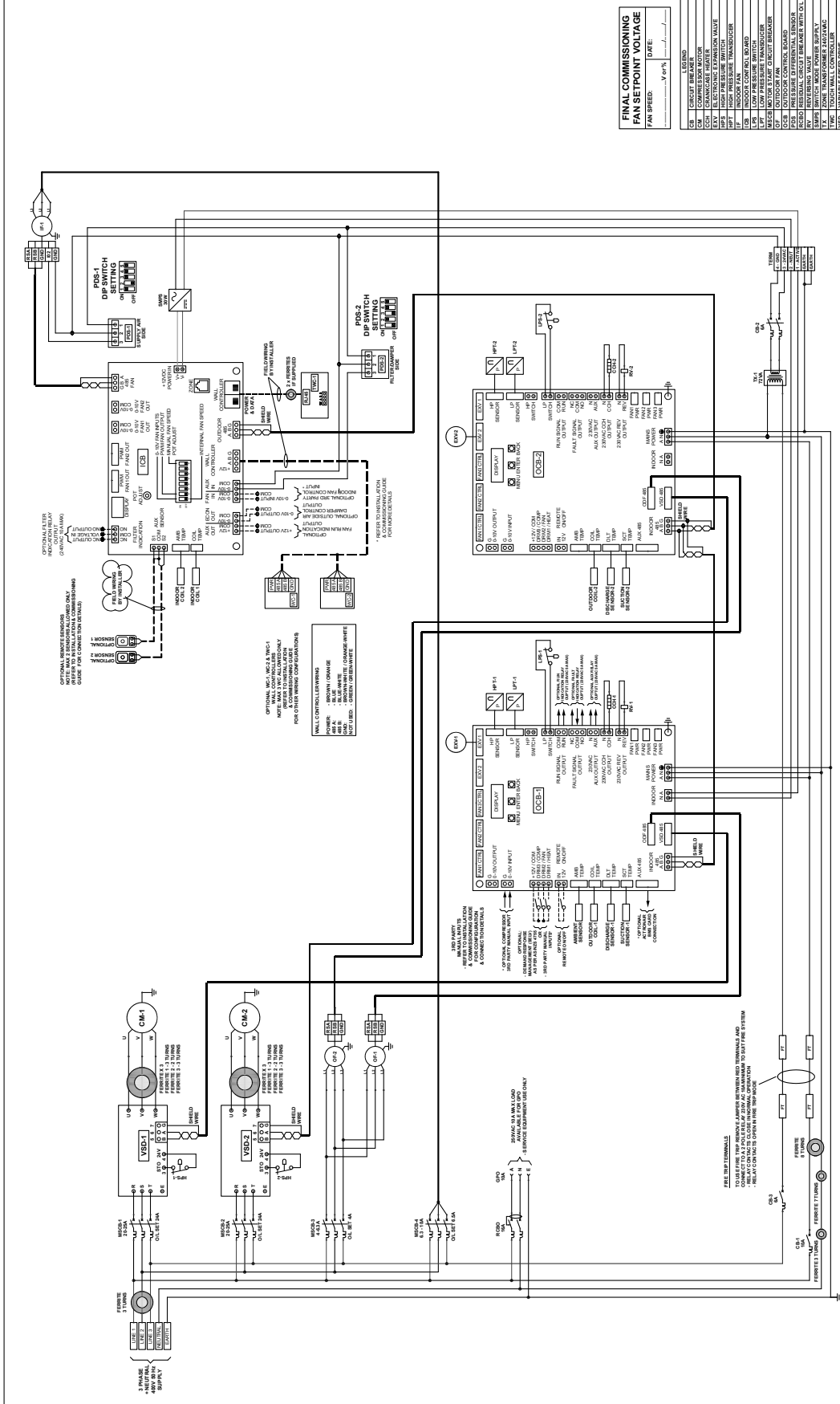

Rev.	Description	By	Date	3768	JL	11/09/2023	Base Model No: PKV720T	Variation Code:	Variation:
							STANDARD		
							Description: UNOPRO VARIABLE CAPACITY CONTROL SYSTEM WITH CMI INDOOR CONTROL BOARD WIRING DIAGRAM		
		PCR					Drawn: JL	22/08/2022	1/1
							Approved: JL	11/09/2023	0515-9030
									Sheet: 1/1
									Revision: B



This drawing remains the intellectual property of Actron Engineering Pty Ltd. Reproduction, modification and/or distribution are prohibited without written consent.

WIRING DIAGRAM - PKV850T

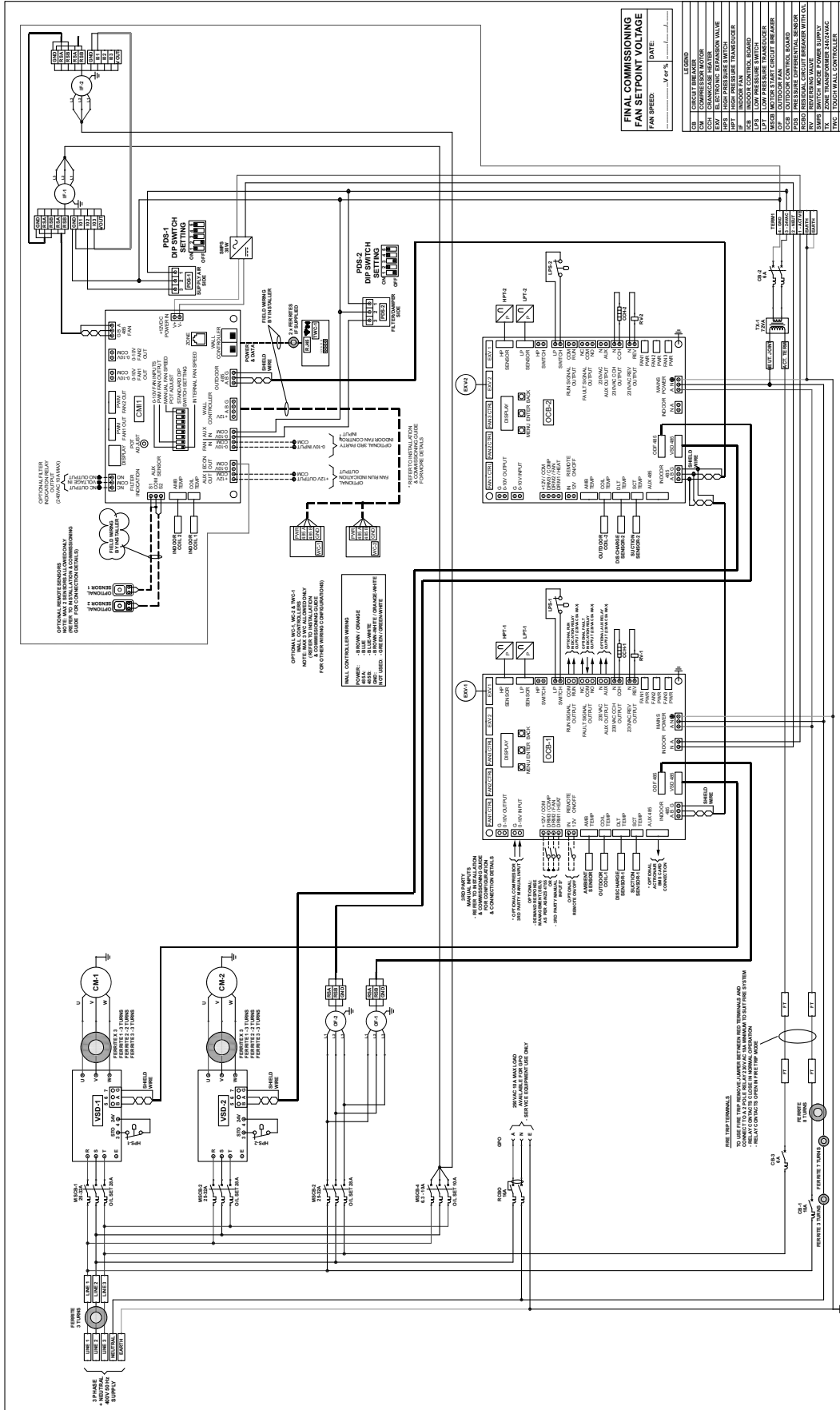

This drawing remains the intellectual property of Actron Engineering Pty Ltd. Reproduction, modification and/or distribution are prohibited without written consent.



WIRING DIAGRAM - PKV960T

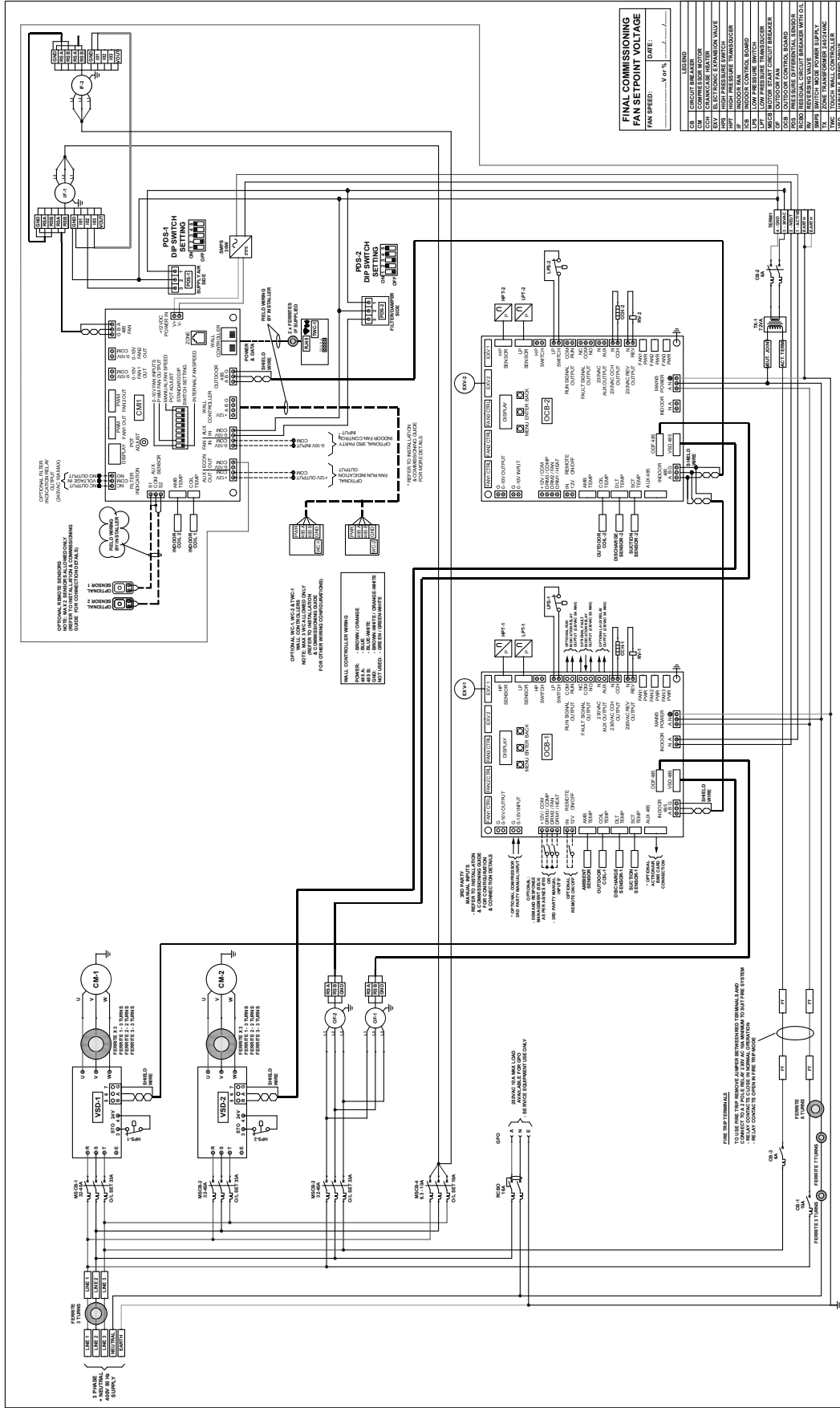

ActronAir <small>This drawing remains the intellectual property of Actron Engineering Pty Ltd. Reproduction, modification and/or distribution are prohibited without written consent.</small>	Base Model No: PKV960T	Variation Code: STANDARD	Variation: STANDARD
PRODUCTION RELEASE	JL 14/02/2024	PCR By	Date
A	Description: UNO PRO VARIABLE CAPACITY CONTROL SYSTEM WITH CMI INDOOR CONTROL BOARD WIRING DIAGRAM		
Rev.	JL 14/02/2024	Drawing No: 0515-9041	Sheet: 1/1
Description	Approved:	JL 14/02/2024	Revision: A



STANDARD UNIT VARIATIONS

SUPPLY OUTLET DIMENSIONS																
LF			LD				LS				LV					
A	B	C	D	E	F	G	H	K	L	M	N	P	Q	R	S	
PKV720T	1498	378	238	385	923	576	170	166	1498	378	238	638	923	576	170	166
PKV850T	1576	464	456	236	TBD	TBD	TBD	1576	464	456	726	TBD	TBD	TBD	TBD	TBD
PKV960T	1576	464	456	236	TBD	TBD	TBD	1576	464	456	726	TBD	TBD	TBD	TBD	TBD

RETURN INLET DIMENSIONS																				
F			D				S				M						V			
1	2	3	4	5	6	7	8	10	11	12	13	10	11	12	18	14	15	16	17	
PKV720T	1498	378	238	385	923	576	170	166	1498	378	238	638	1498	378	238	82	923	576	170	166
PKV850T	1576	464	456	238	TBD	TBD	TBD	1576	464	456	726	1576	464	456	77	TBD	TBD	TBD	TBD	TBD
PKV960T	1576	464	456	238	TBD	TBD	TBD	1576	464	456	726	1576	464	456	77	TBD	TBD	TBD	TBD	TBD

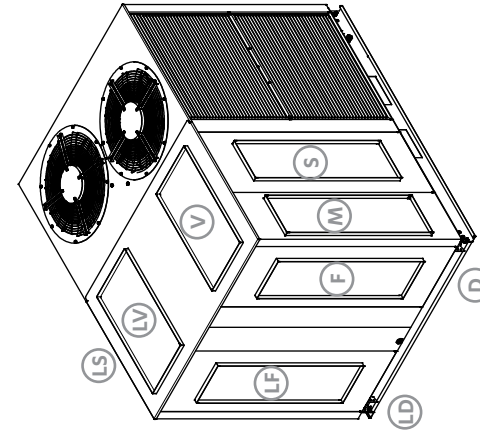
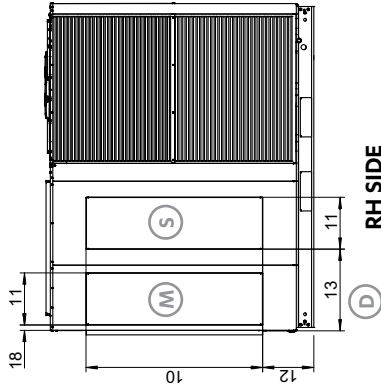
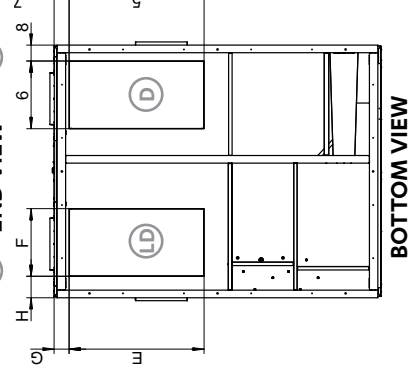
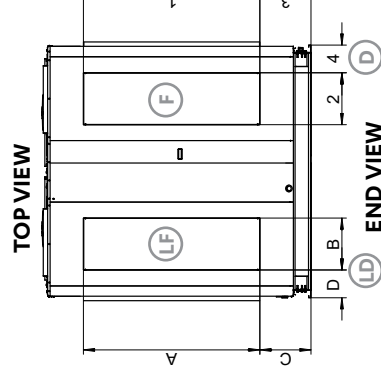
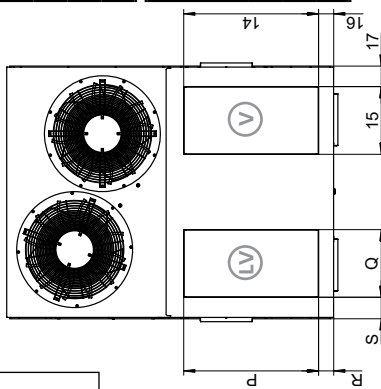

LEGEND FOR SUPPLY POSITIONS
 LD = LEFT DOWN SUPPLY
 LF = LEFT FRONT SUPPLY
 LS = LEFT SIDE SUPPLY
 LV = LEFT VERTICAL SUPPLY

LEGEND FOR RETURN POSITIONS
 D = RIGHT DOWN RETURN
 F = RIGHT FRONT RETURN
 S = RIGHT SIDE RETURN
 V = RIGHT VERTICAL RETURN

NOTES

- Unit viewed from air handling end.
- Size and position of return & supply are indicative only, see table for actual size and position for each particular model.
- All flanges are outside dimensions.
- All dimensions are from outside edge of base.
- PKV960T shown for illustration purposes only, unit may vary depending on model/capacity.

**STANDARD PKV720-960T
 SUPPLY & RETURN
 L**T VARIATIONS**



STANDARD UNIT VARIATIONS

SUPPLY OUTLET DIMENSIONS

	LF			LD			LS			LV						
	A	B	C	D	E	F	G	H	K	L	M	N	P	Q	R	S
PKV720T	1498	378	238	385	923	576	170	166	1498	378	238	638	923	576	170	166
PKV850T	1576	464	456	236	TBD	TBD	TBD	TBD	1576	464	456	726	TBD	TBD	TBD	TBD
PKV960T	1576	464	456	236	TBD	TBD	TBD	TBD	1576	464	456	726	TBD	TBD	TBD	TBD

RETURN INLET DIMENSIONS

	D										M*										V										OA																																
	1	2	3	4	5	6	7	8	1	2	3	22	14	15	16	17	18	19	20	21	1	2	3	22	14	15	16	17	18	19	20	21	1	2	3	22	14	15	16	17	18	19	20	21	18	19	20																
PKV720T	1498	378	238	385	923	576	170	166	1498	378	238	82	923	576	170	166	1502	400	326	629	1498	378	238	385	923	576	170	166	1498	378	238	82	923	576	170	166	1502	400	326	629	1498	378	238	385	923	576	170	166	1498	378	238	82	923	576	170	166	1502	400	326	629	18	19	20
PKV850T	1576	464	456	247	TBD	TBD	TBD	TBD	1576	464	456	77	TBD	TBD	TBD	TBD	1706	657	407	631	1576	464	456	247	TBD	TBD	TBD	TBD	1576	464	456	77	TBD	TBD	TBD	TBD	1706	657	407	631	1576	464	456	247	TBD	TBD	TBD	TBD	1576	464	456	77	TBD	TBD	TBD	TBD	1706	657	407	631	TBD	TBD	TBD
PKV960T	1576	464	456	247	TBD	TBD	TBD	TBD	1576	464	456	77	TBD	TBD	TBD	TBD	1706	657	407	631	1576	464	456	247	TBD	TBD	TBD	TBD	1576	464	456	77	TBD	TBD	TBD	TBD	1706	657	407	631	1576	464	456	247	TBD	TBD	TBD	TBD	1576	464	456	77	TBD	TBD	TBD	TBD	1706	657	407	631	TBD	TBD	TBD

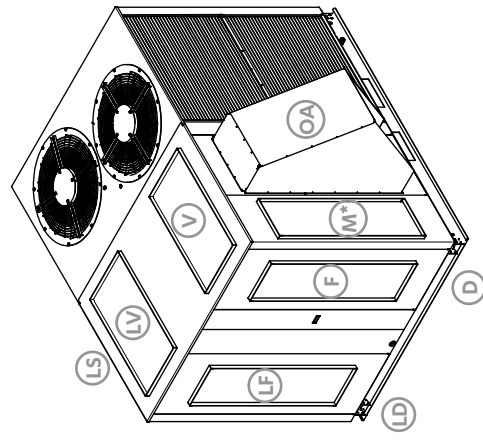
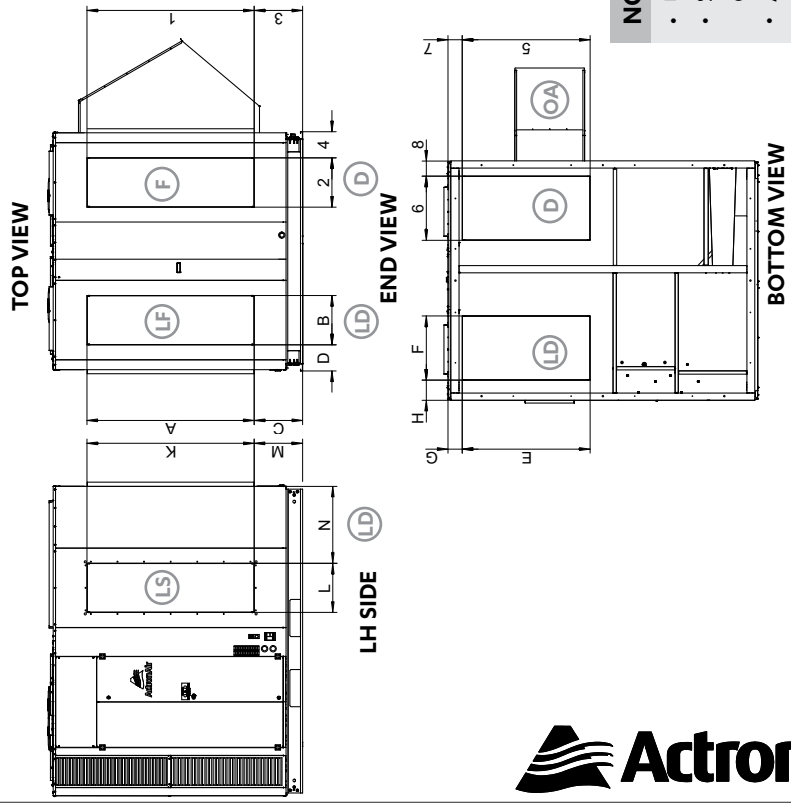
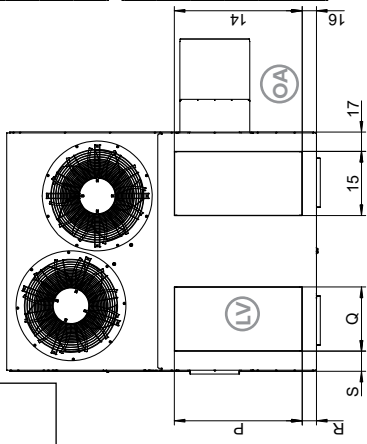

LEGEND FOR SUPPLY POSITIONS
 LD = LEFT DOWN SUPPLY
 LF = LEFT FRONT SUPPLY
 LS = LEFT SIDE SUPPLY
 LV = LEFT VERTICAL SUPPLY

LEGEND FOR RETURN POSITIONS
 D = RIGHT DOWN RETURN
 F = RIGHT FRONT RETURN
 OA = OUTSIDE AIR RETURN

NOTE: WEATHERHOOD IS AN OPTION

NOTES

- Unit viewed from air handling end.
- Size and position of return & supply are indicative only, see table for actual size and position for each particular model.
- All flanges are outside dimensions.
- All dimensions are from outside edge of base.
- PKV960T shown for illustration purposes only, unit may vary depending on model/capacity.
- *M: available for M Option only (3 dampers)

**STANDARD PKV720-960T
 SUPPLY & RETURN
 L**T-E VARIATIONS**



STANDARD UNIT VARIATIONS

SUPPLY OUTLET DIMENSIONS

	RF			RD			RS			RV						
	A	B	C	D	E	F	G	H	K	L	M	N	P	Q	R	S
PKV720T	1498	378	238	385	923	576	170	166	1498	378	238	638	923	576	170	166
PKV850T	1576	464	456	236	TBD	TBD	TBD	TBD	1576	464	456	726	TBD	TBD	TBD	TBD
PKV960T	1576	464	456	236	TBD	TBD	TBD	TBD	1576	464	456	726	TBD	TBD	TBD	TBD

RETURN INLET DIMENSIONS

	F			D			S			M			V			
	1	2	3	4	5	6	7	8	10	11	12	13	14	15	16	17
PKV720T	1498	378	238	385	923	576	170	166	1498	378	238	638	923	576	170	166
PKV850T	1576	464	456	238	TBD	TBD	TBD	TBD	1576	464	456	726	TBD	TBD	TBD	TBD
PKV960T	1576	464	456	238	TBD	TBD	TBD	TBD	1576	464	456	726	TBD	TBD	TBD	TBD

**STANDARD PKV720-960T
SUPPLY & RETURN
R**T VARIATIONS**

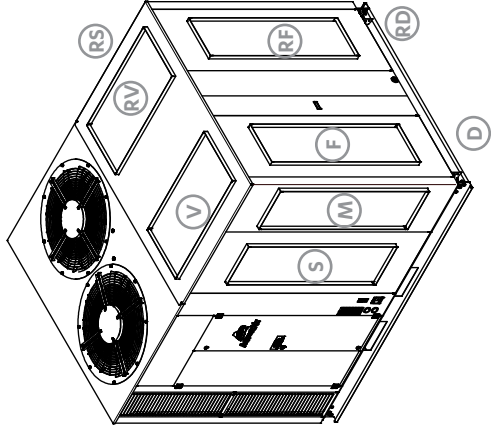
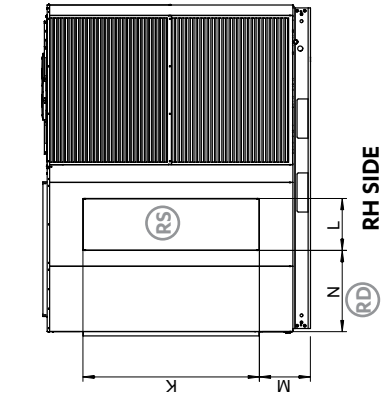
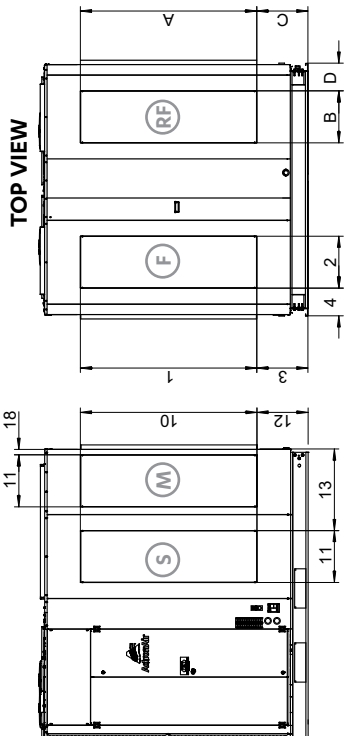
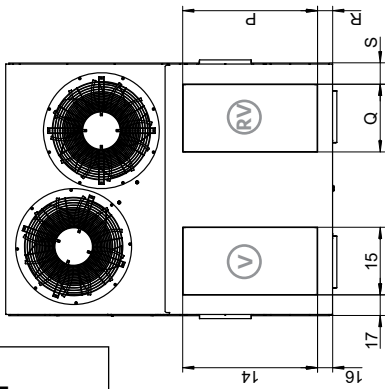

LEGEND FOR SUPPLY POSITIONS
 RD = RIGHT DOWN SUPPLY
 RF = RIGHT FRONT SUPPLY
 RS = RIGHT SIDE SUPPLY
 RV = RIGHT VERTICAL SUPPLY

LEGEND FOR RETURN POSITIONS
 D = LEFT DOWN RETURN
 F = LEFT FRONT RETURN
 S = LEFT SIDE RETURN
 V = LEFT VERTICAL RETURN

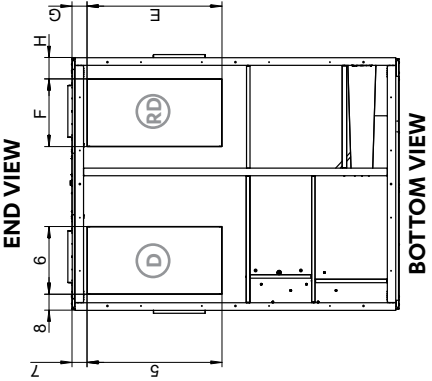

NOTES

- Unit viewed from air handling end.
- Size and position of return & supply are indicative only, see table for actual size and position for each particular model.
- All flanges are outside dimensions.
- All dimensions are from outside edge of base.
- PKV960T shown for illustration purposes only, unit may vary depending on model/capacity.



STANDARD UNIT VARIATIONS

SUPPLY OUTLET DIMENSIONS

	RF			RD			RS			RV						
	A	B	C	D	E	F	G	H	K	L	M	N	P	Q	R	S
PKV720T	1498	378	238	385	923	576	170	166	1498	378	238	638	923	576	170	166
PKV850T	1576	464	456	236	TBD	TBD	TBD	TBD	1576	464	456	726	TBD	TBD	TBD	TBD
PKV960T	1576	464	456	236	TBD	TBD	TBD	TBD	1576	464	456	726	TBD	TBD	TBD	TBD

RETURN INLET DIMENSIONS

	D							M*							V			OA		
	1	2	3	4	5	6	7	8	1	2	3	22	14	15	16	17	18	19	20	21
PKV720T	1498	378	238	385	923	576	170	166	1498	378	238	82	923	576	170	166	1502	400	326	629
PKV850T	1576	464	456	247	TBD	TBD	TBD	TBD	1576	464	456	77	TBD	TBD	TBD	TBD	1706	657	407	631
PKV960T	1576	464	456	247	TBD	TBD	TBD	TBD	1576	464	456	77	TBD	TBD	TBD	TBD	1706	657	407	631

**STANDARD PKV720-960T
SUPPLY & RETURN
R**T-E VARIATIONS**

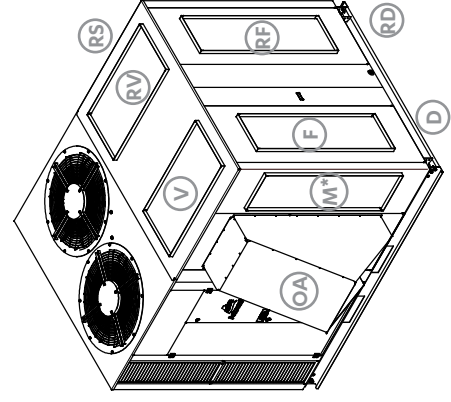
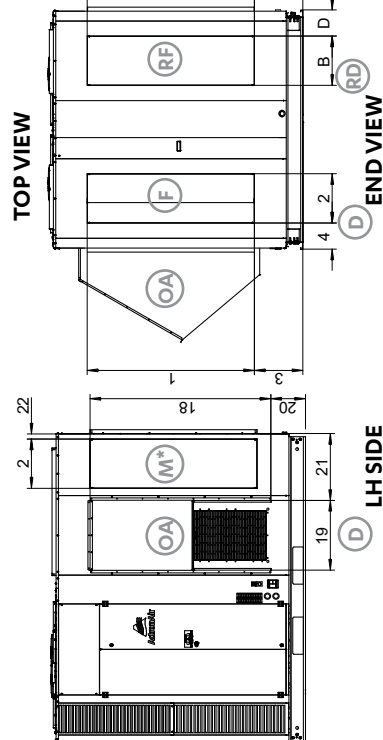
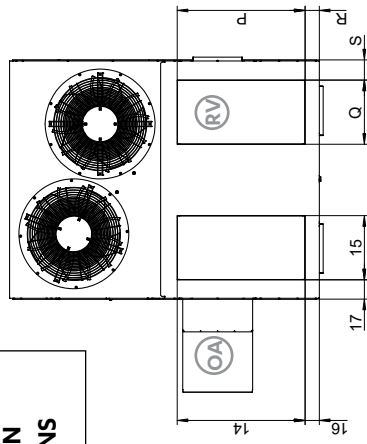

LEGEND FOR SUPPLY POSITIONS
 RD = RIGHT DOWN SUPPLY
 RF = RIGHT FRONT SUPPLY
 RS = RIGHT SIDE SUPPLY
 RV = RIGHT VERTICAL SUPPLY

LEGEND FOR RETURN POSITIONS
 D = LEFT DOWN RETURN
 F = LEFT FRONT RETURN
 OA = OUTSIDE AIR RETURN
 NOTE: WEATHERHOOD IS AN OPTION

NOTES

- Unit viewed from air handling end.
- Size and position of return & supply are indicative only, see table for actual size and position for each particular model.
- All flanges are outside dimensions.
- All dimensions are from outside edge of base.
- PKV960T shown for illustration purposes only, unit may vary depending on model/capacity.
- *M: available for M Option only (3 dampers)



AIRFLOW CONFIGURATION CHANGE

For Airflow configuration where Supply and/or Return air is required on the SIDE (LFST, RFST, LSFT, RSFT, LSDT, RSDT, LSST, RSST, LSTT and RSTT), the Airflow Access Panel will have to be interchanged with the Front Panel before installation of duct.

Sample below is converting the LFFT unit to LSST airflow configuration.

***Panels A and B may have rectangular holes (for Economizer option) depending on the unit purchased**

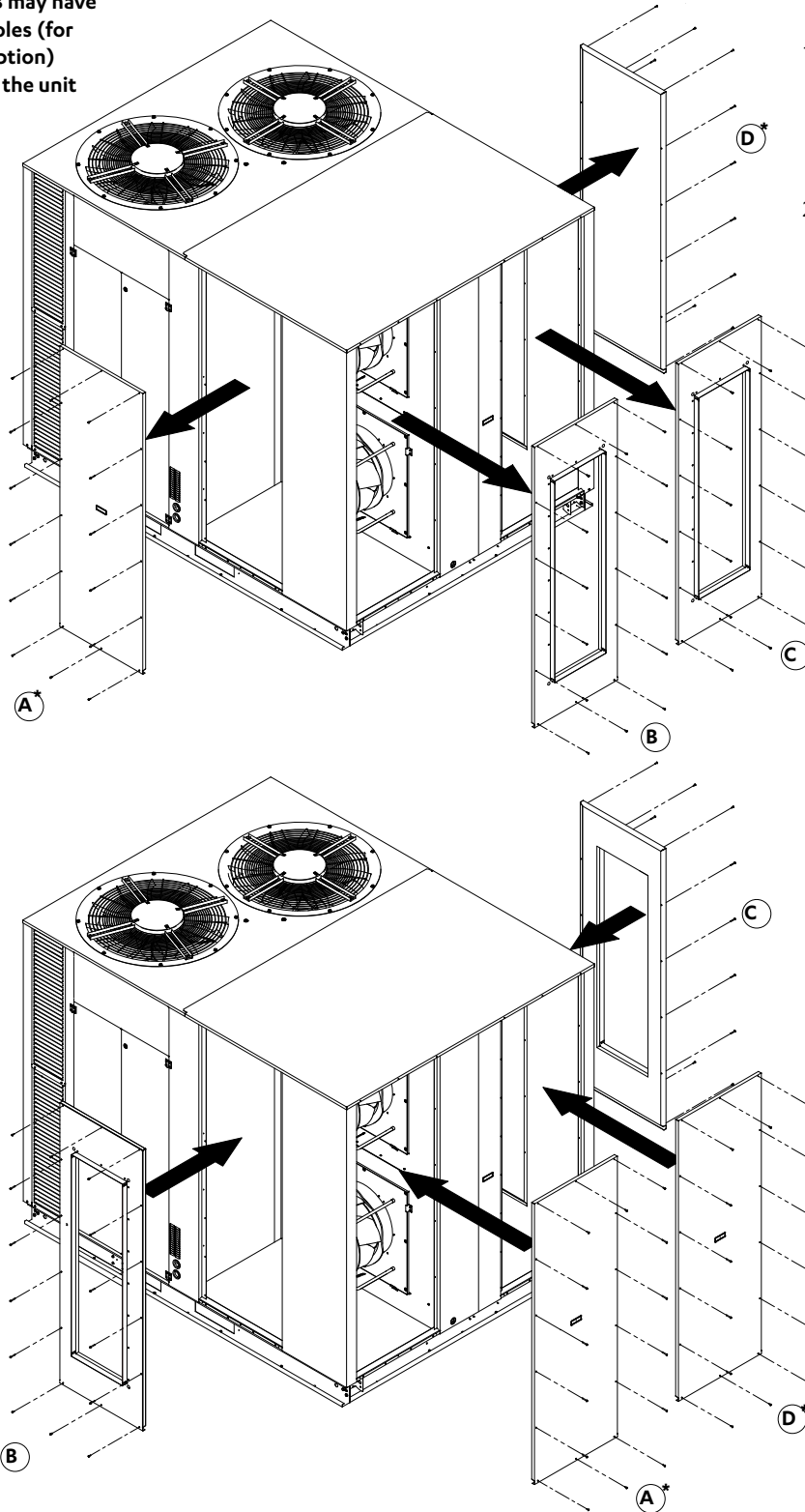

1. Remove Airflow Access Panel (B and C). Referring to the illustration on the left, both the panels on the front are removed.
2. Remove the Panels on the sides (A and D) mounted on the side.

3. Mount the Airflow Access Panel (B and C) on the Left and the Right side.
4. Mount the Panels removed from the side (A and D) on to the front.

Variable Capacity Commercial Inverter Package Ducted Units PKV720T-960T

Index

- Technical Selection Data (Unit and Control Features)
- Specification Summary
- Capacity Selection Data
- Indoor Fan Data
- Indoor Fan Curve
- Unit Dimensions
- Service Clearances and Weights
- Unit Base Dimensions
- Sound Data
- Specifications
- Wiring Diagram
- Standard Unit Variations