

ECOFLEX MINI VRF

FLOOR STANDING / UNDER CEILING INDOOR UNIT

TECHNICAL SELECTION DATA



Model Numbers

- MFF-022CS
- MFF-028CS
- MFF-036CS
- MFF-045CS
- MFF-056CS
- MFF-071CS
- MFF-080CS

Table of Contents

01. Specification	2
02. Dimensions	3
03. Unit Placement	4
04. Piping Diagram	5
05. Wiring Diagram	6
06. Capacity Tables	7
07. Electrical Characteristics	8
08. Set external static pressure parameters	8
09. Fan Performance	9
10. Sound Levels	13
11. Temperature and Airflow Distributions	15



01.Specification

Model			MFF-022CS	MFF-028CS	MFF-036CS	MFF-045CS	MFF-056CS	MFF-071CS	MFF-080CS	
Power supply			1-phase, 230V, 50Hz							
Cooling ¹	Capacity	kW	2.2	2.8	3.6	4.5	5.6	7.1	8.0	
		kBtu/h	7.5	9.6	12.3	15.4	19.1	24.2	27.3	
	Power Input	W	35	35	40	44	45	53	62	
Heating ²	Capacity	kW	2.4	3.2	4	5	6.3	8.0	9.0	
		kBtu/h	8.2	10.9	13.7	17.1	21.5	27.3	30.7	
	Power Input	W	35	35	41	46	47	57	64	
Fan motor type	Type	DC								
	Number	1								
Indoor Coil	Number of rows		2	2	3	3	2	3	3	
	Tube pitch × row pitch	mm	22×19.05							
	Fin spacing and type	mm	1.6							
	Fin type	Hydrophilic aluminum								
	Tube OD and type	mm	Copper Ø 8 Inner-groove							
	Number of circuits		2		4		3		5	
Design pressure (H/L)		MPa	4.4/2.6							
Pipe connections	Liquid and Gas pipe		Ø6.35mm and Ø12.7mm (1/4" and 1/2")					Ø9.52mm and Ø15.9mm (3/8" and 5/8")		
	Drain pipe	mm	OD Ø 18.5							
Air flow rate ³ (Max / Min) ⁷		l/s	141 / 121	141 / 121	148 / 115	191 / 146	259 / 212	293 / 234	293 / 234	
Sound pressure level ⁴ (Max / Min) ⁷		dB(A)	36 / 32	36 / 32	38 / 32	43 / 37	41.5 / 36	46 / 41	46 / 41	
External static pressure		Pa	0-10							
Indoor Coil Dimensions (L×H×W)		mm	580×38.1×176		580×57.2×176		920×38.1×264	920×57.2×264		
Unit	Net dimensions ⁶ (W×H×D)	mm	1020×495×200			1240×495×200	1360×591×200			
	Packed dimensions (W×H×D)	mm	1125×595×285			1345×595×285	1465×695×285			
	Net/Gross weight	kg	21.1/27.9		21.9/28.6	26.3/32.9	32.1/41.0	33.3/41.1	33.3/42.1	

Notes:

- Indoor temperature 27°C DB, 19°C WB; outdoor temperature 35°C DB; equivalent refrigerant piping length 5m with zero level difference.
- Indoor temperature 20°C DB; outdoor temperature 7°C DB, 6°C WB; equivalent refrigerant piping length 5m with zero level difference.
- Air flow rates are from the highest speed to the lowest speed, total 7 rates for each model.
- Sound pressure level is from highest level to lowest level, total 7 levels for each model. Sound pressure level is measured 1.4m below the unit in a Sem-anechoic chamber.
- Sound power level is from highest level to lowest level, total 7 levels for each model.
- Unit body dimensions given are the largest external dimensions of the unit, including hanger attachments.
- Refer to the section Sound Levels for more details.

02. Dimensions

02.01. Unit Dimensions

Figure 2.1: MFS series Floor Standing / Under Ceiling dimensions

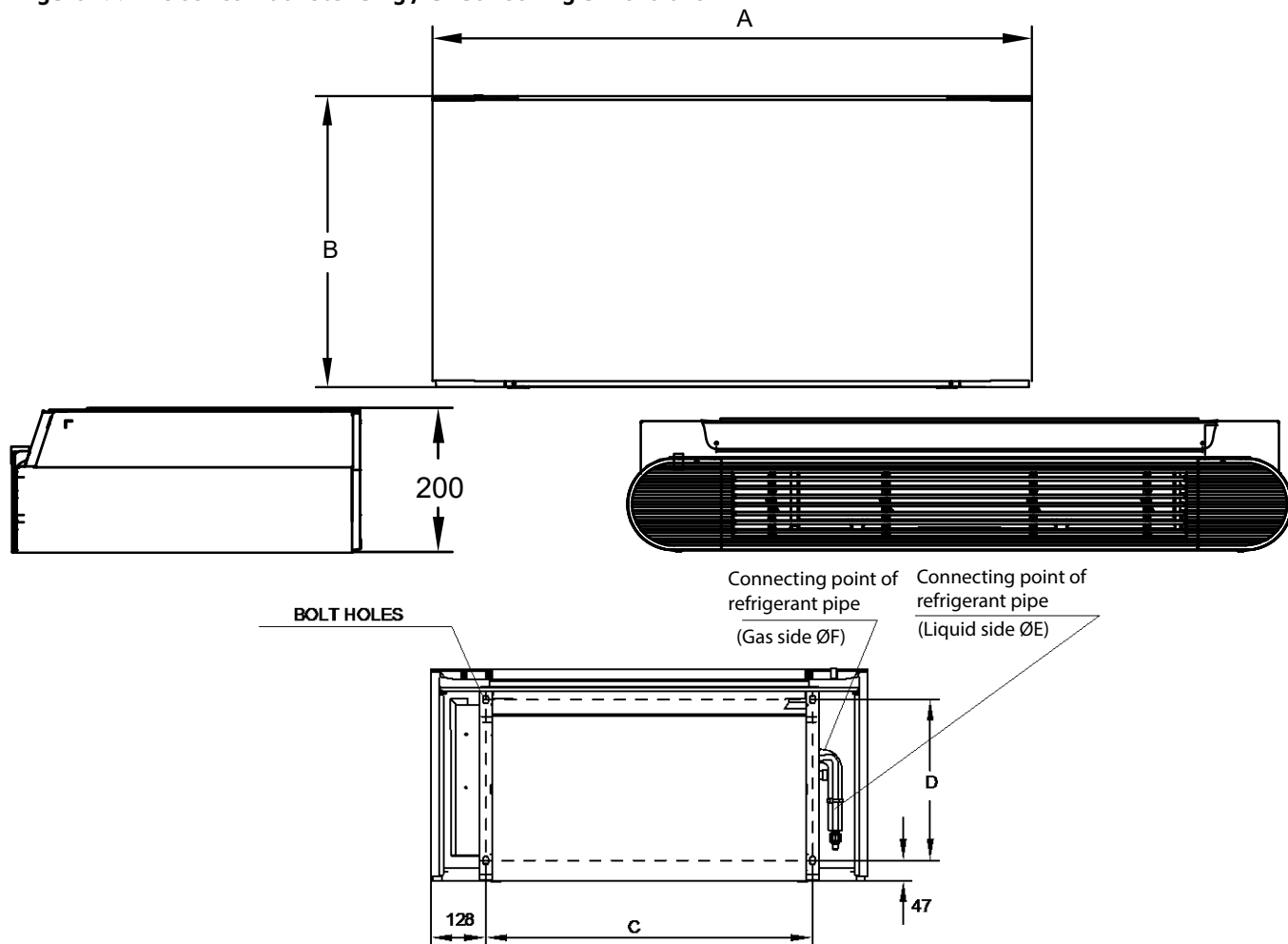

Table 2.1: MFF series Floor Standing / Under Ceiling dimensions

Model	Dimensions(mm)			
	A	B	C	D
MFF-022CS	1020	495	764	375
MFF-028CS				
MFF-036CS				
MFF-045CS	1240	495	984	375
MFF-056CS	1360	591	1104	391
MFF-071CS				
MFF-080CS				

Table 2.2: MFF series piping Floor Standing / Under Ceiling connections

Model	E (mm)	F (mm)
MFF-022CS	6.35	12.7
MFF-028CS		
MFF-036CS		
MFF-045CS		
MFF-056CS		
MFF-071CS	9.52	15.9
MFF-080CS		

03. Unit Placement

03.01. Placement Considerations

Unit placement should take account of the following considerations:

- Units should not be installed in the following locations:
 - A place filled with mineral oil, fumes or mist, like a kitchen.
 - A place where there are corrosive gases, such as acid or alkaline gases.
 - A place exposed to combustible gases and using volatile combustible gases such as diluent or gasoline.
 - A place where there is equipment emitting electromagnetic radiation.
 - A place where there is a high salt content in the air e.g. coastal environment.
 - Do not use the air conditioner in an environment where an explosion may occur.
 - Places like in vehicles or cabin rooms.
 - Factories with major voltage fluctuations in the power supplies.
 - Other special environmental conditions.
- Units should be installed in positions where:
 - Ensure that the airflow in and out of the Indoor Unit is reasonably organized to form an air circulation in the room.
 - Ensure Indoor Unit maintenance space.
 - The nearer the drainage pipe and copper pipe are to the Outdoor Unit, the lower the pipe cost is.
 - Prevent the air conditioner from blowing directly to the human body.
 - The closer the wiring to the power cabinet, the lower the wiring cost is.
 - Keep the air-conditioning return air away from the setting sun of the room.
 - Be careful not to interfere with the light tank, fire pipe, gas pipe and other facilities.
 - The Indoor Unit should not be lifted in the places like load-bearing beam and columns that affect the structural safety of the house.
 - The wired controller and the Indoor Unit should be in the same installation space; otherwise, the sampling point setting of the wired controller need to be changed.

03.02. Space Requirements

Figure 3.1: MFF series (air inlet from front) space requirements (unit: mm)

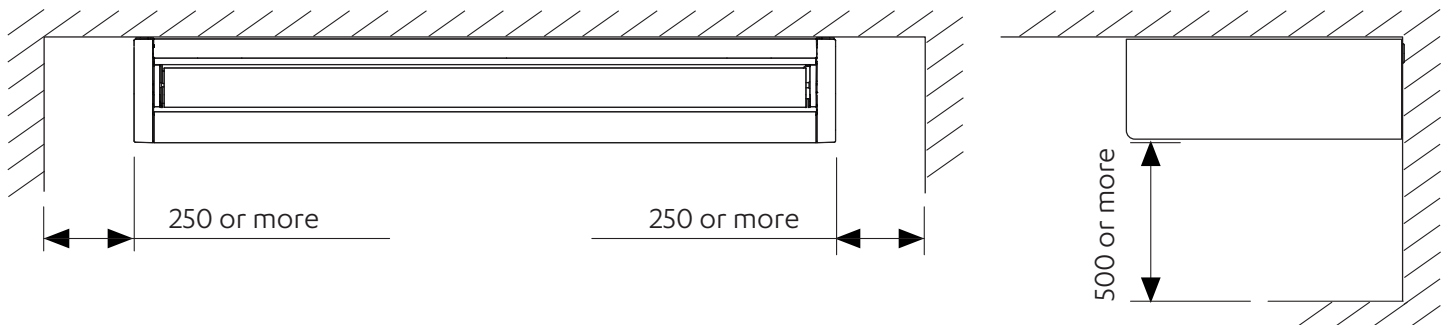

04. Piping Diagram

Figure 4.1: Floor Standing / Under Ceiling piping diagram

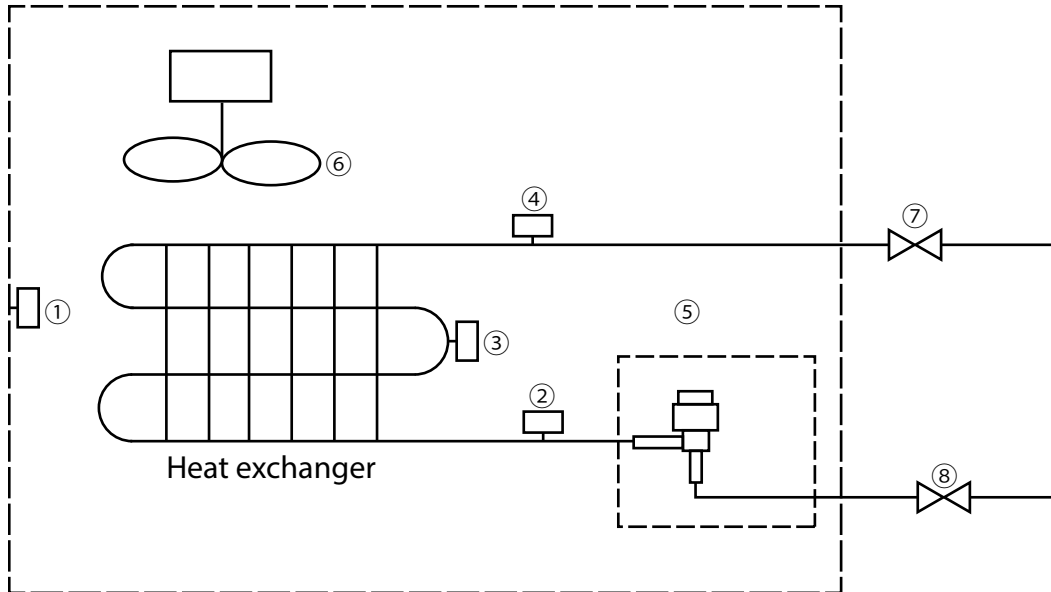

Legend		
①	T1	Inlet Air Temp. Sensor
②	T2A	Liquid Pipe Temp. Sensor
③	T2	Middle Pipe Temp. Sensor
④	T2B	Gas Pipe Temp. Sensor
⑤	EXV	Electronic expansion valve
⑥	FM	Fan motor
⑦	-	Gas side (Flare Nut)
⑧	-	Liquid side (Flare Nut)

05. Wiring Diagram

Figure 5.1: Floor Standing / Under Ceiling wiring diagram

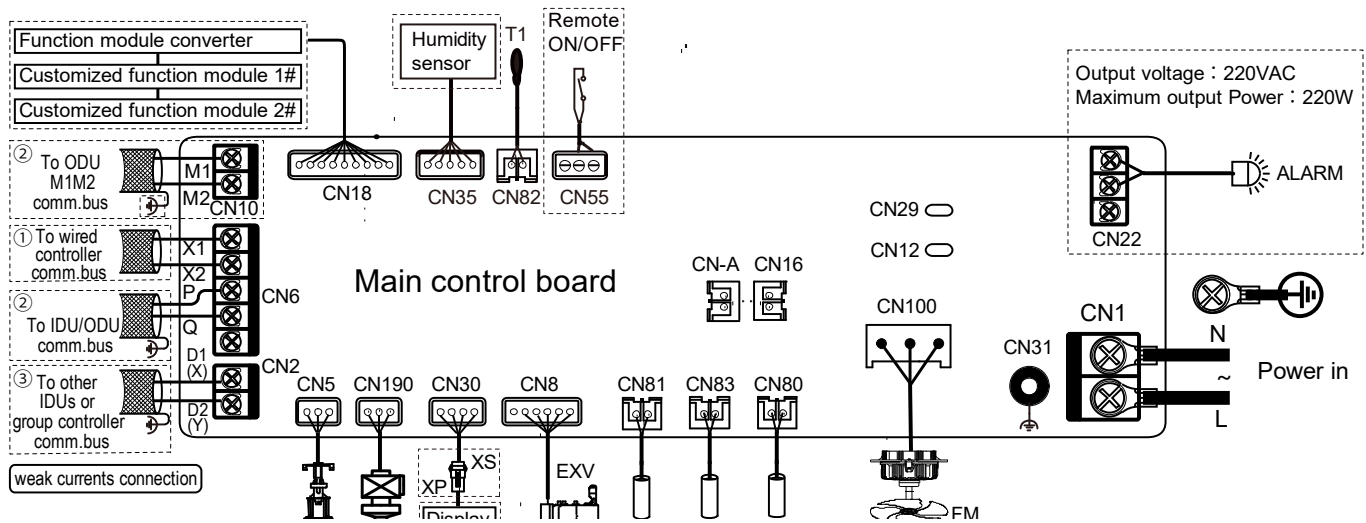

Installation Notes

CAUTION

- All installation, servicing and maintenance must be carried out by competent and suitably qualified, certified and accredited professionals and in accordance with all applicable legislation.
- Units should be grounded in accordance with all applicable legislation. Metal and other conductive components should be insulated in accordance with all applicable legislation.
- Power supply wiring should be securely fastened at the power supply terminals – loose power supply wiring would represent a fire risk.
- After installation, servicing or maintenance, the electric control box cover must be closed. Failing to close the electric control box cover risks fire or electric shock.
- The dotted lines indicate the field wiring or optional function.
- PQ and M1M2 communication ports both are used for indoor and outdoor communication, and only one of them can be used at a time. Meanwhile, be sure to connect the same communication ports (PQ to PQ; M1M2 to M1M2) to prevent damage to the main control board.
- D1D2 communication ports are used for group control communication. When connecting the group controller, the D1D2 port of the indoor units that are to be group controlled must be connected in a daisy chain, and the group controller must be connected to the X1X2 port of one of the indoor units in the group control, and set to group control mode. In addition, D1D2 communication ports can also be connected to the central controller.

06.Capacity Tables

06.01. Cooling Capacity Table

Table 6.1: Floor Standing / Under Ceiling cooling capacity

Model	Indoor air temperature (°C WB/DB)													
	14/20		16/23		18/26		19/27		20/28		22/30		24/32	
	TC	SC	TC	SC	TC	SC	TC	SC	TC	SC	TC	SC	TC	SC
MFF-022CS	2.0	1.9	2.1	1.9	2.2	1.9	2.2	1.8	2.3	1.8	2.3	1.7	2.4	1.7
MFF-028CS	2.5	2.3	2.7	2.4	2.8	2.4	2.8	2.3	2.9	2.3	2.9	2.2	3.0	2.1
MFF-036CS	3.2	3.0	3.4	3.1	3.6	3.1	3.6	3.0	3.7	3.0	3.8	2.8	3.9	2.7
MFF-045CS	4.0	3.7	4.3	3.8	4.5	3.9	4.5	3.7	4.6	3.6	4.7	3.5	4.8	3.3
MFF-056CS	5.0	4.6	5.3	4.7	5.6	4.8	5.6	4.6	5.7	4.5	5.8	4.3	6.0	4.1
MFF-071CS	6.3	5.8	6.7	5.9	7.0	6.0	7.1	5.8	7.2	5.7	7.4	5.4	7.6	5.2
MFF-080CS	7.1	6.3	7.6	6.5	7.9	6.6	8.0	6.5	8.1	6.3	8.3	6.0	8.5	5.8

Abbreviations:

TC: Total capacity (kW)

SC: Sensible capacity(kW)

Notes:

1. Shaded cells indicate rated conditions.

06.02. Heating Capacity Table

Table 6.2: Floor Standing / Under Ceiling heating capacity

Model	Indoor air temperature (°C DB)					
	16	18	20	21	22	24
	SHC	SHC	SHC	SHC	SHC	SHC
MFF-022CS	2.6	2.6	2.4	2.3	2.3	2.1
MFF-028CS	3.4	3.4	3.2	3.1	3.0	2.8
MFF-036CS	4.2	4.2	4.0	3.8	3.8	3.5
MFF-045CS	5.3	5.3	5.0	4.8	4.7	4.4
MFF-056CS	6.7	6.6	6.3	6.1	5.9	5.5
MFF-071CS	8.5	8.4	8.0	7.8	7.5	7.0
MFF-080CS	9.5	9.5	9.0	8.7	8.5	7.8

Abbreviations:

SHC: Sensible heating capacity(kW)

Notes:

1. Shaded cells indicate rated conditions.

07. Electrical Characteristics

Table 7.1: Floor Standing / Under Ceiling electrical characteristics

Model	Power Supply						Indoor Fan Motors	
	Hz	Rated Volts	Min. volts	Max. volts	MCA	MFA	Rated motor output (kW)	FLA
MFF-022CS	50	230	217	243	0.3	15	50	0.5
MFF-028CS	50	230	217	243	0.3	15	50	0.5
MFF-036CS	50	230	217	243	0.3	15	50	0.5
MFF-045CS	50	230	217	243	0.3	15	50	0.5
MFF-056CS	50	230	217	243	0.4	15	60	0.6
MFF-071CS	50	230	217	243	0.4	15	60	0.6
MFF-080CS	50	230	217	243	0.4	15	60	0.6

Abbreviations:

MCA: Minimum Circuit Amps

MFA: Maximum Fuse Amps

FLA: Full Load Amps

08. Set external static pressure parameters

In the main interface, press "≡"+"↵" for 3 seconds at the same time, and the main interface will display "CC". Press the "▲" and "▼" to select the indoor unit ("n00-n63" is displayed, and the last two digits are the indoor unit addresses). Press the "↵" to enter the parameter setting interface, and "n00" will be displayed.

When "n00" is displayed, press the "↵" to enter the static pressure setting. Use the "▲" and "▼" keys to adjust to the demand parameter values, and press the "↵" to confirm.

Press the "⌚" button to return to the previous menu and exit the parameter setting. Parameter setting will also exit after 60 s of no operation.

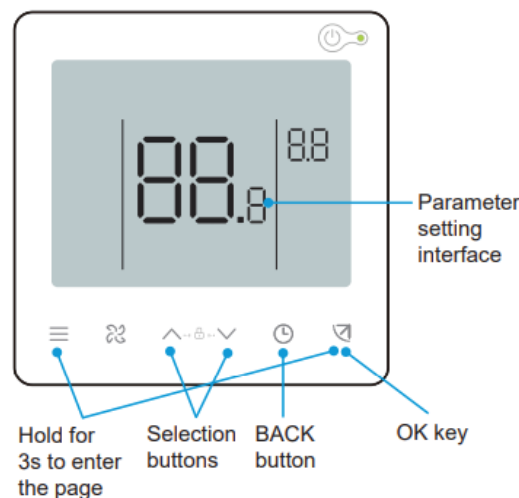

Table 8.1: External static pressure setting (Exposed)-MFF

First level menu	Second level menu	Description	Default				
n00	02/04/06/07/08/09/10	Static pressure level	2				
Level	2	4	6	7	8	9	10
Static pressure(Pa)	0	10	20	30	40	50	60

Notes:

The above is only an example of 86S wired controller. If you choose other controllers, please refer to their manuals for setting.

09. Fan Performance

Figure 9.1: MFF-022CS fan performance

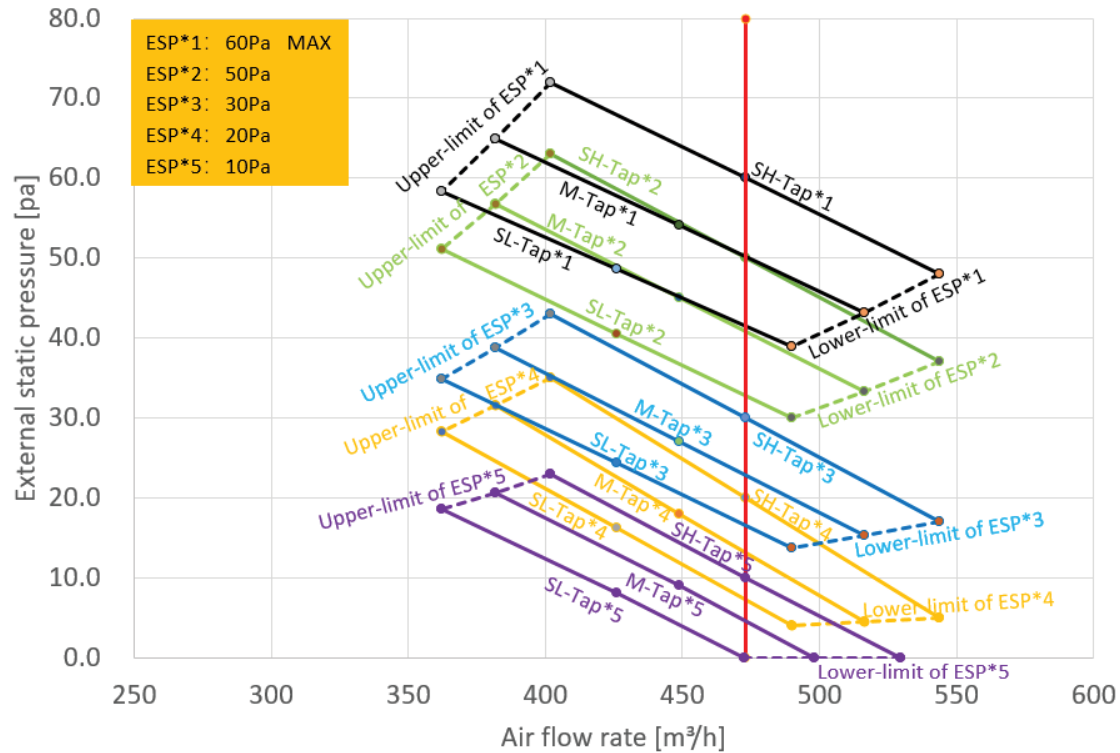
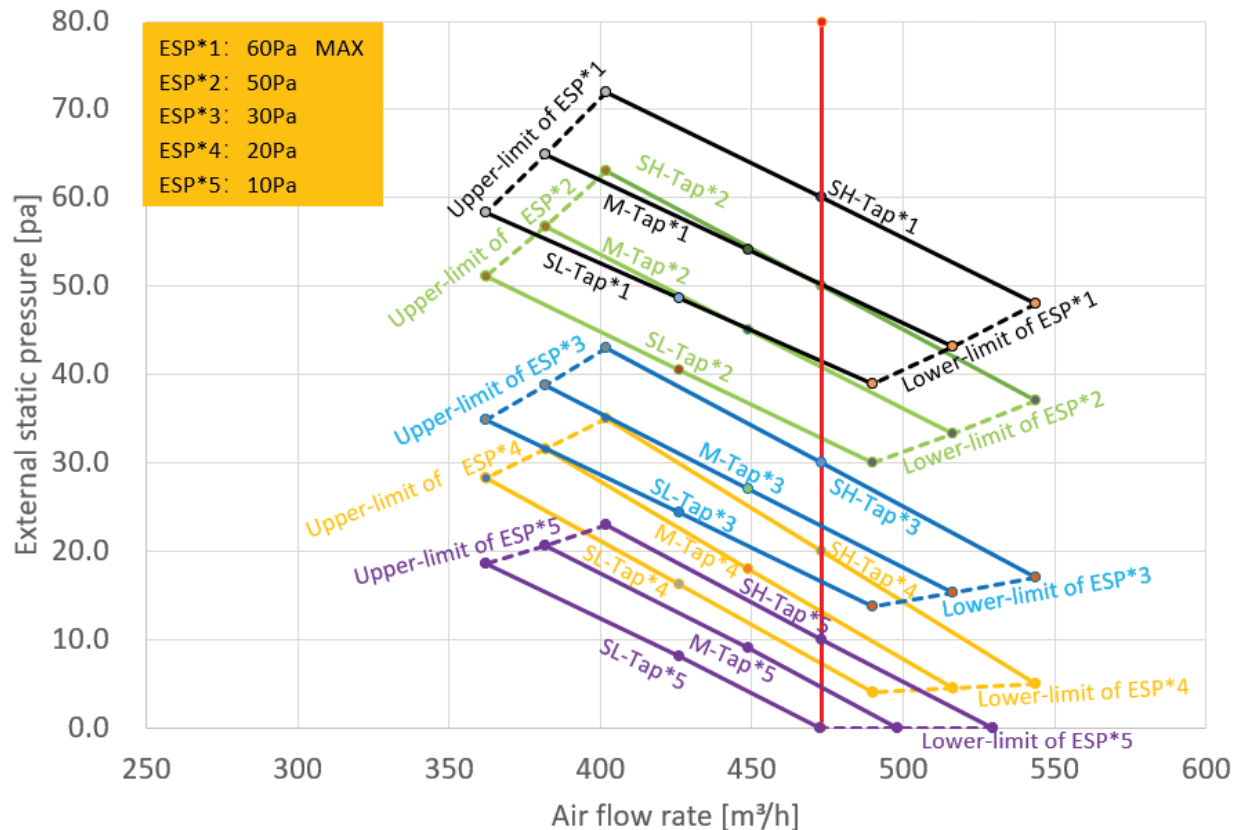

Figure 9.1: MFF-028CS fan performance



TECHNICAL SELECTION DATA

ECOFLEX - Mini VRF

Figure 9.3: MFF-036CS fan performance

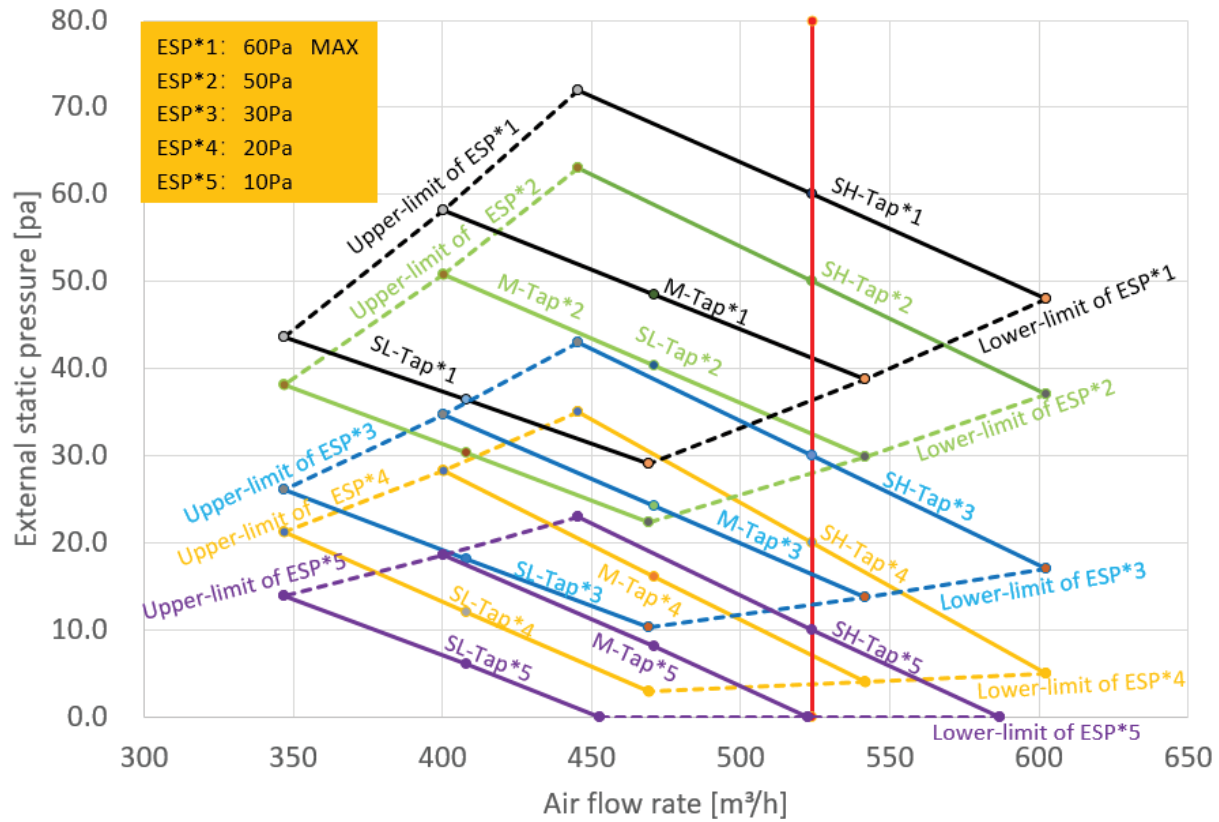

Figure 9.4: MFF-045CS fan performance

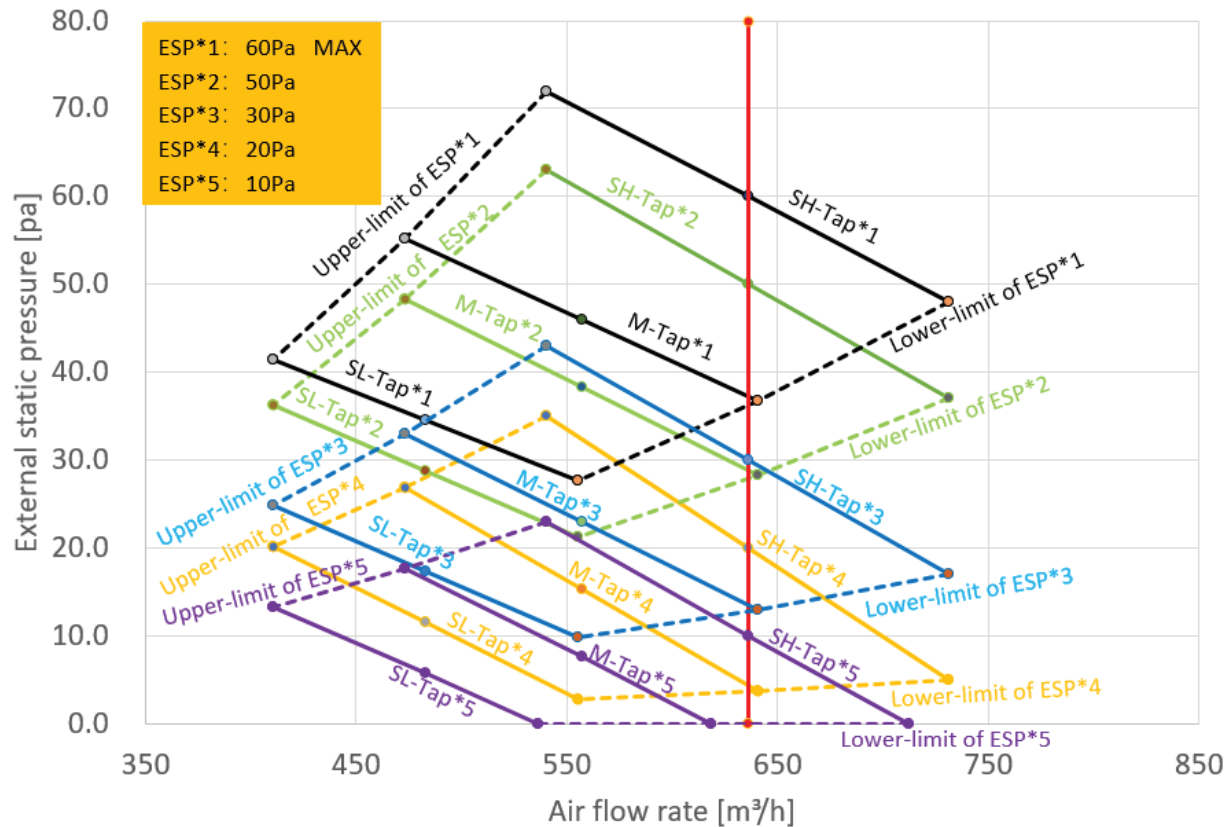

Figure 9.5: MFF-056CS fan performance

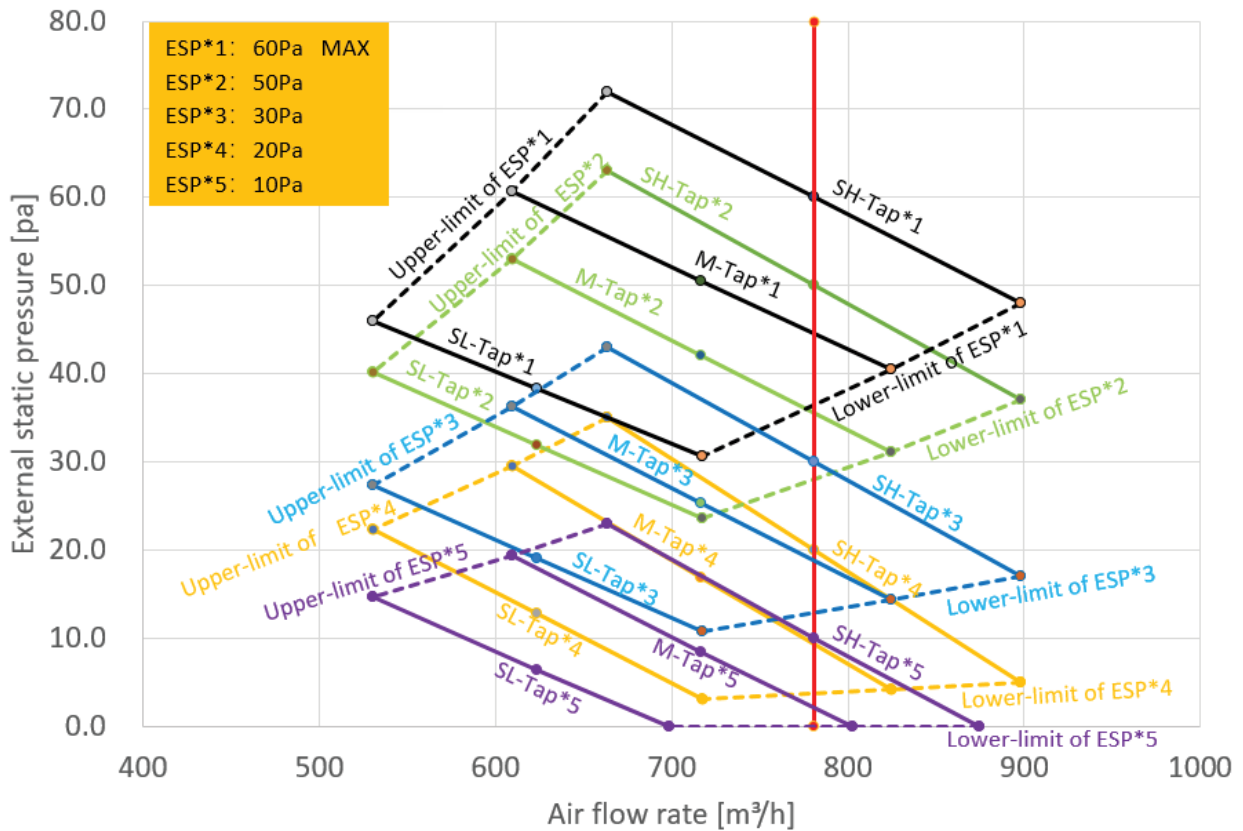

Figure 9.6: MFF-071CS fan performance

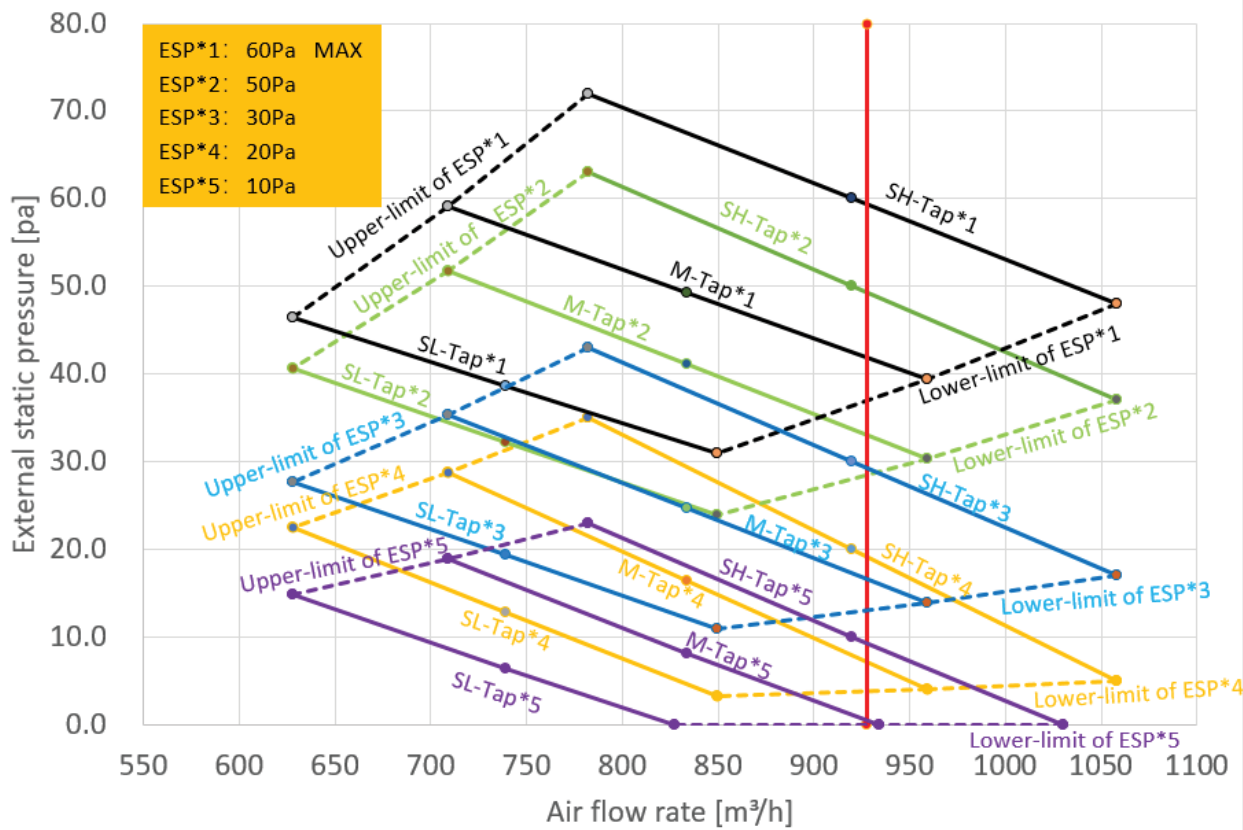
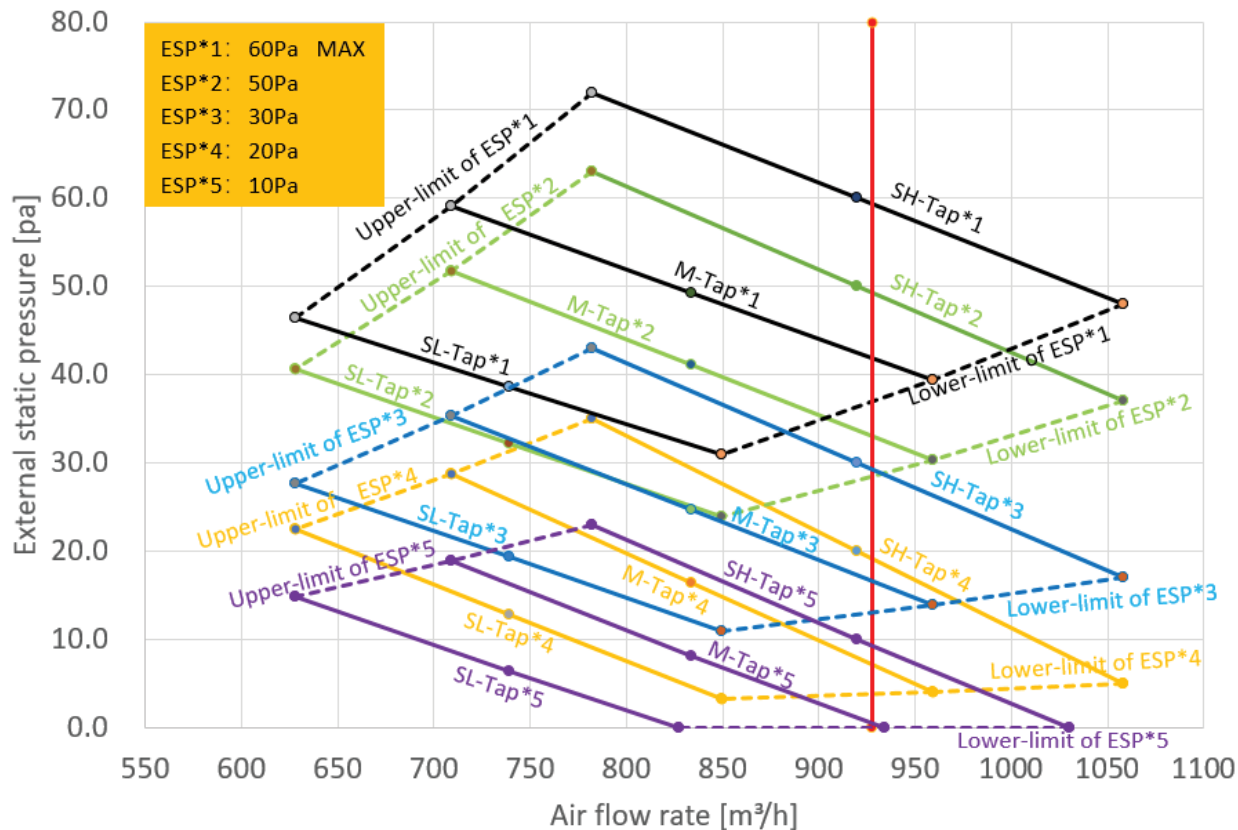

Figure 9.7: MFF-080CS fan performance



10. Sound Levels

10.01. Overall

Table 10.1.1: Floor Standing / Under Ceiling sound pressure levels¹

Model name	Sound pressure levels dB(A)						
	SSH	SH	H	M	L	SL	SSL
MFF-022CS	36.0	35.0	34.5	34.0	33.0	32.5	32.0
MFF-028CS	36.0	35.0	34.5	34.0	33.0	32.5	32.0
MFF-036CS	38.0	37.0	36.0	35.0	34.0	33.0	32.0
MFF-045CS	43.0	42.0	41.0	40.0	39.0	38.0	37.0
MFF-056CS	41.5	41.0	40.0	39.0	38.0	37.0	36.0
MFF-071CS	46.0	45.5	45.0	44.0	43.0	42.0	41.0
MFF-080CS	46.0	45.5	45.0	44.0	43.0	42.0	41.0

Notes:

1. Sound pressure levels are measured at 1m in front of the unit at a height of 1.5m in a anechoic chamber. During in-situ operation, sound pressure levels may be higher as a result of ambient noise.

Figure 10.1: Floor Standing sound pressure level measurement

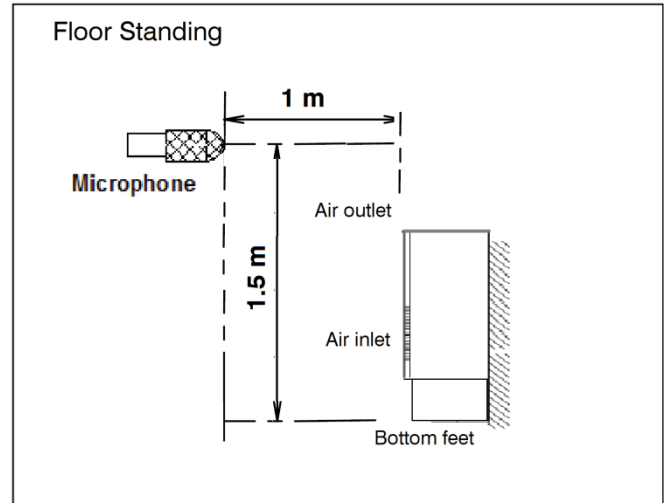

Table 10.1.2: Floor Standing / Under Ceiling Air flow rate (OPa).

Model name	Air flow rate (OPa)						
	SSH	SH	H	M	L	SL	SSL
MFF-022CS	141	136	134	129	125	125	121
MFF-028CS	141	136	134	129	125	125	121
MFF-036CS	148	142	139	134	129	121	115
MFF-045CS	191	184	178	169	160	156	146
MFF-056CS	259	251	247	239	228	218	212
MFF-071CS	293	281	276	265	257	247	234
MFF-080CS	293	281	276	265	257	247	234

10.02. Octave Band Levels

Figure 10.1: MFF-022CS octave band levels

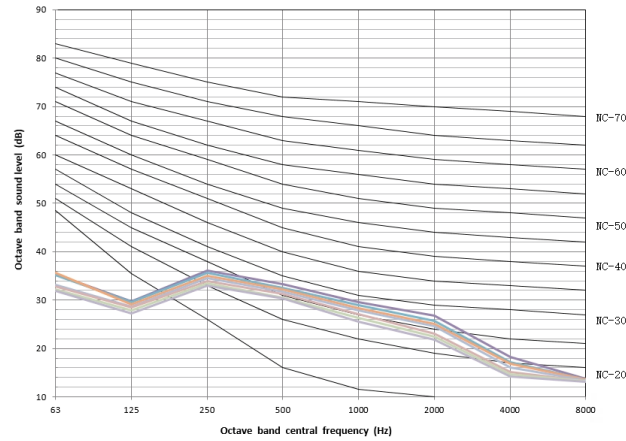

Figure 10.2: MFF-028CS octave band levels

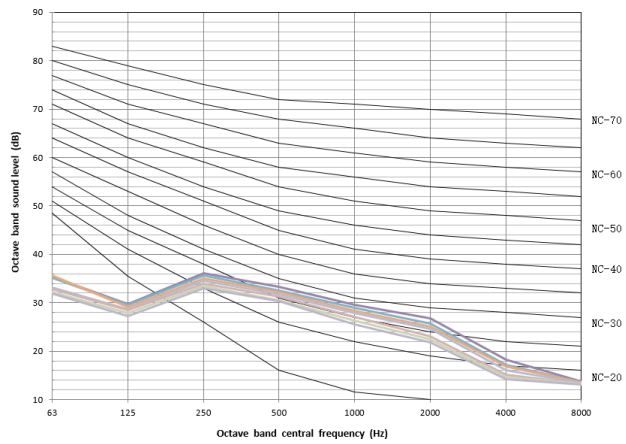

Figure 10.3: MFF-036CS octave band levels

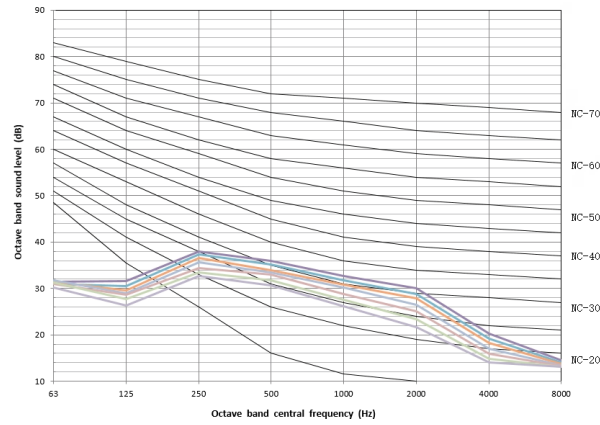

Figure 10.4: MFF-045CS octave band levels

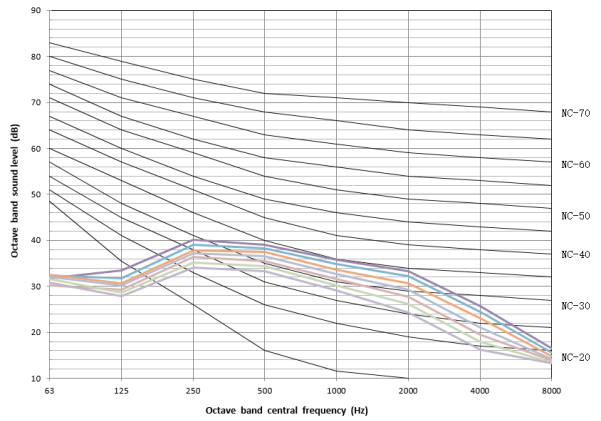

Figure 10.5: MFF-056CS octave band levels

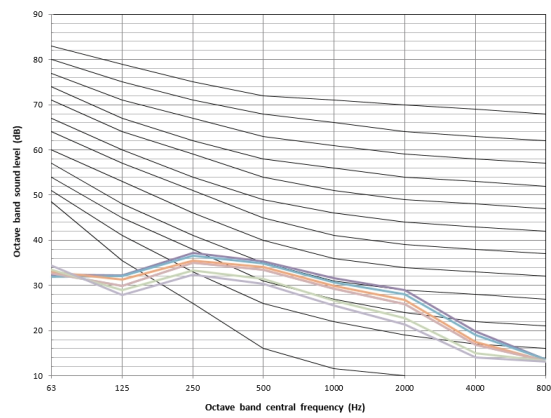

Figure 10.6: MFF-071CS octave band levels

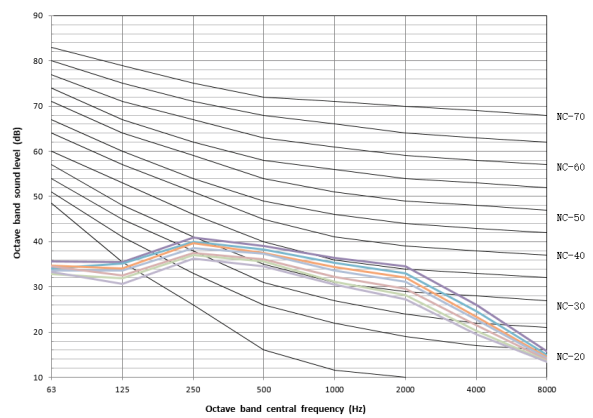
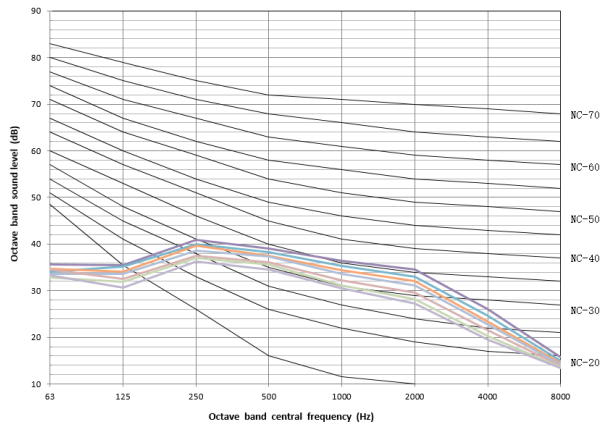

Figure 10.7: MFF-080CS octave band levels



11. Temperature and Airflow Distributions

11.01. Simulate condition

Table 11.1: Floor Standing / Under Ceiling simulate condition

Model name	Room size (m)	Ceiling height (m)	Flow angle (Cooling/Heating)	Placing
MFF-022CS	6×6	2.4	90°/125°	Standing
MFF-028CS	6×6	2.4	90°/125°	Standing
MFF-036CS	6×6	2.4	90°/125°	Standing
MFF-045CS	6×6	2.4	90°/125°	Standing
MFF-056CS	6×6	2.4	90°/125°	Standing
MFF-071CS	6×6	2.4	90°/125°	Standing
MFF-080CS	6×6	2.4	90°/125°	Standing

Note:

1. These figures are based on software simulation. They show typical temperature and airflow distributions in the conditions above. In the actual installation, they may differ from these figures under the influence of air temperature conditions, ceiling height, cooling/heating load, obstacles, etc.

11.02. Airflow distributions (unit: m/s)

In the below charts, Y-Axis represents the height in meters (charts shows the installation height at 2.5m) and the X-Axis represents the floor distance in meters. These chart shows the air speed distribution 300s after the machine is turned on. The data in the curves shows air speed in meter per seconds (eg: 0.5 means the air speed in that area is 0.5m/s).

Figure 11.1: MFF-022CS cooling at 300S

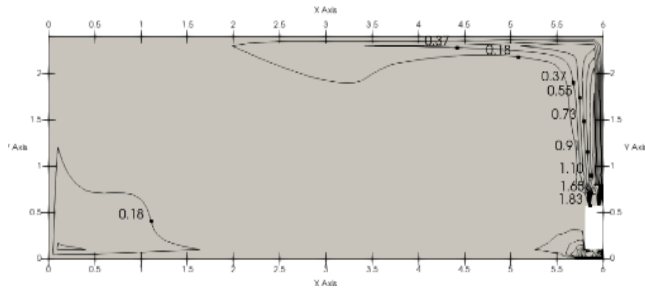

Figure 11.2: MFF-022CS heating at 300S

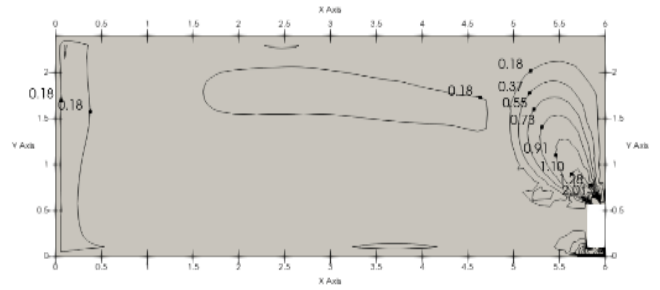

Figure 11.3: MFF-028CS cooling at 300S

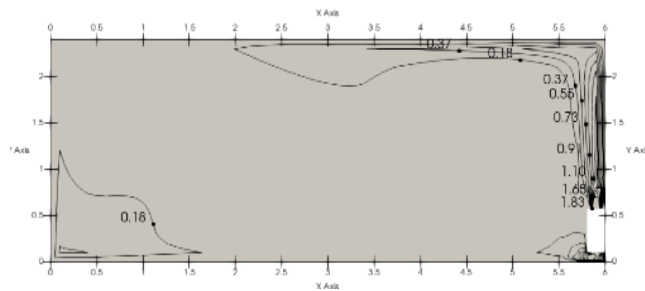

Figure 11.4: MFF-028CS heating at 300S

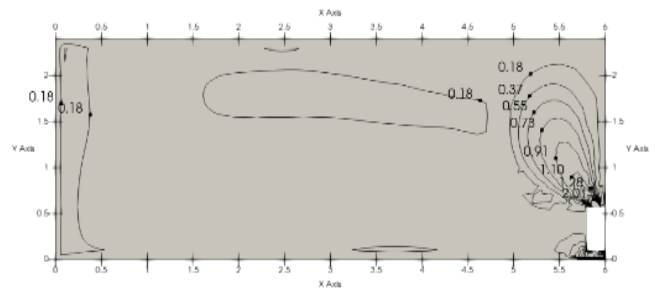

Figure 11.5: MFF-036CS cooling at 300S

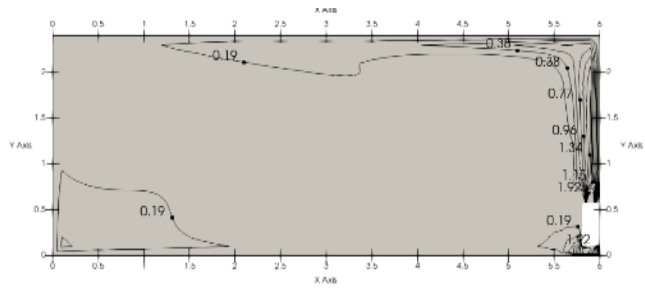

Figure 11.6: MFF-036CS heating at 300S

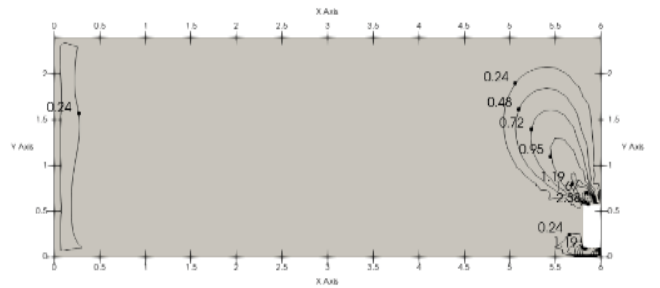

Figure 11.7: MFF-045CS cooling at 300S

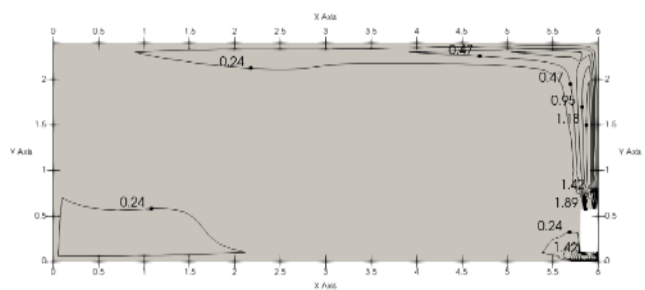
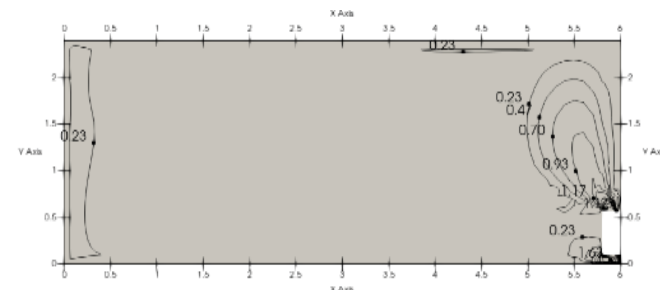

Figure 11.8: MFF-045CS heating at 300S



TECHNICAL SELECTION DATA

ECOFLEX - Mini VRF

Figure 11.9: MFF-056CS cooling at 300S

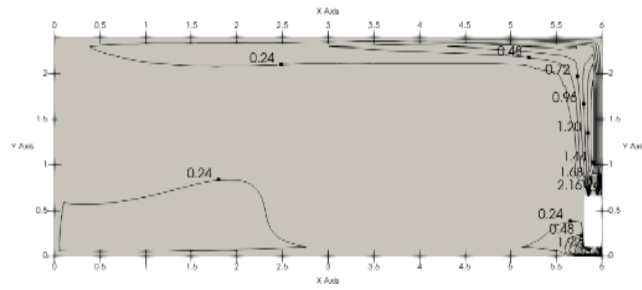

Figure 11.10: MFF-056CS heating at 300S

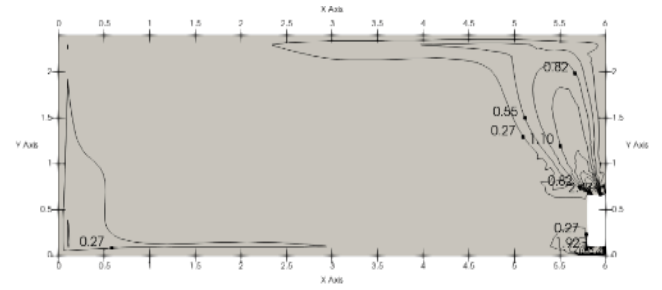

Figure 11.11: MFF-071CS cooling at 300S

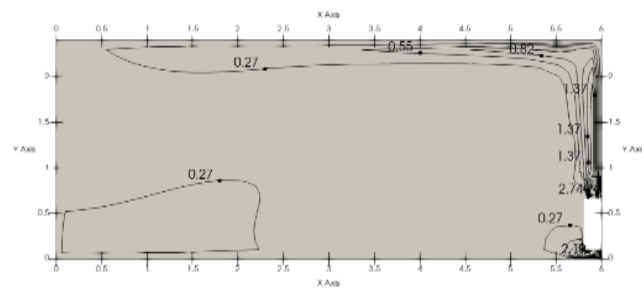

Figure 11.12: MFF-071CS heating at 300S

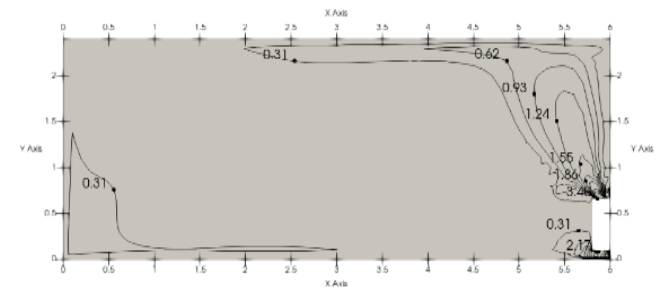

Figure 11.13: MFF-080CS cooling at 300S

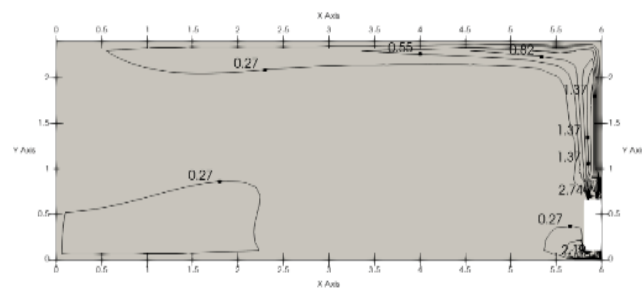
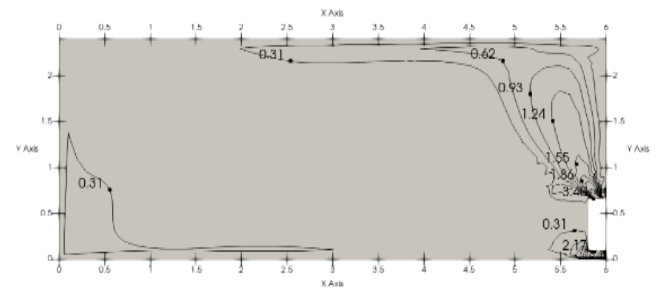

Figure 11.14: MFF-080CS heating at 300S



11.03. Temperature distributions

In the below charts, Y-Axis represents the height in meters (charts shows the installation height at 2.5m) and the X-Axis represents the floor distance in meters. These chart shows the air speed distribution 300s after the machine is turned on. The data in the curves shows temperature distribution.

Figure 11.15: MFF-022CS cooling at 300S

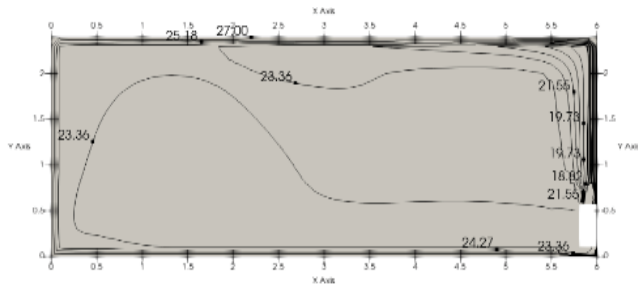

Figure 11.16: MFF-022CS heating at 300S

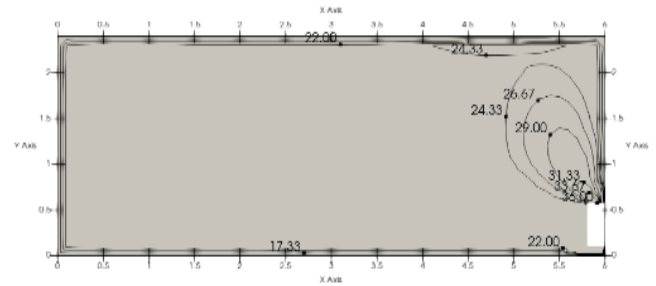

Figure 11.17: MFF-028CS cooling at 300S

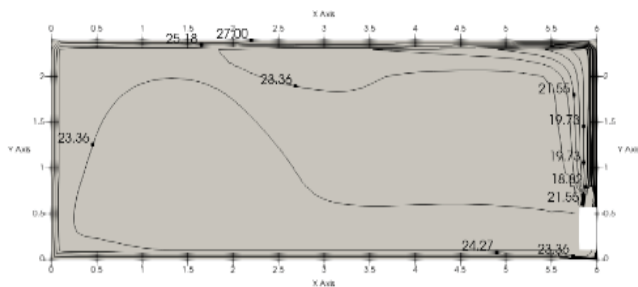

Figure 11.18: MFF-028CS heating at 300S

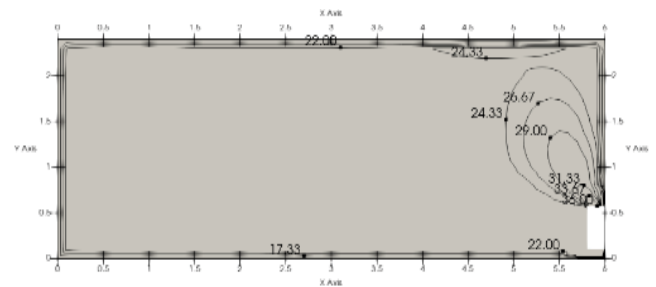

Figure 11.19: MFF-036CS cooling at 300S

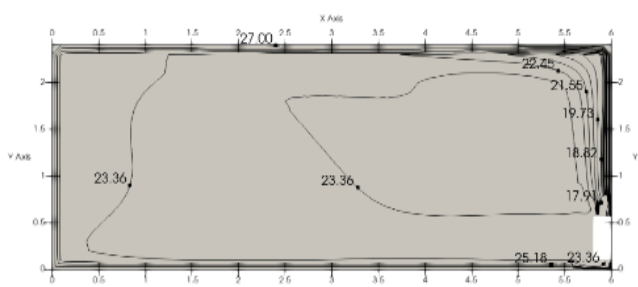

Figure 11.20: MFF-036CS heating at 300S

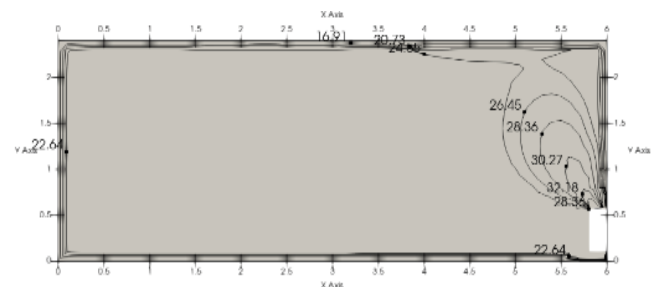

Figure 11.21: MFF-045CS cooling at 300S

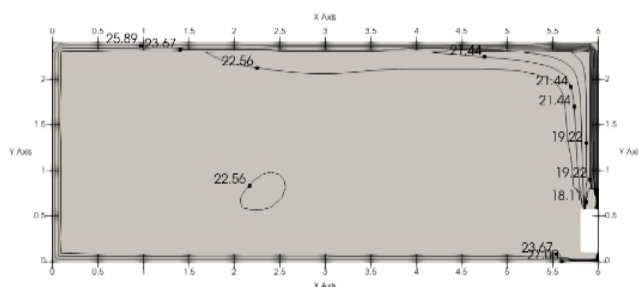

Figure 11.22: MFF-045CS heating at 300S

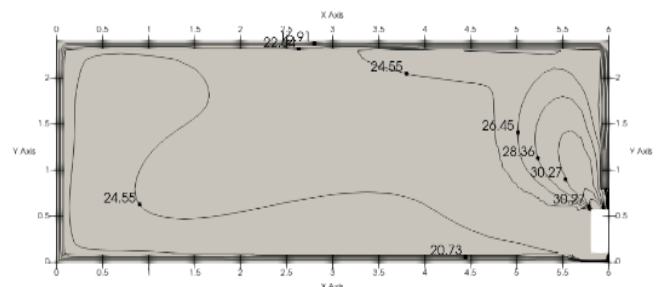

Figure 11.23: MFF-056CS cooling at 300S

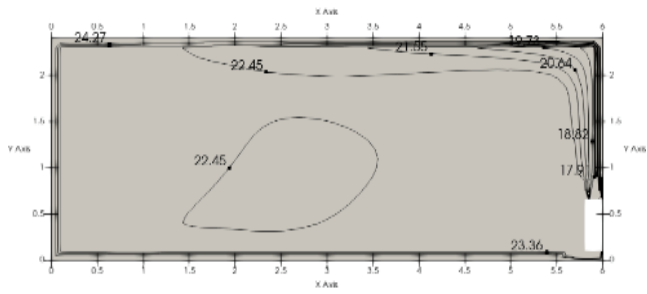

Figure 11.24: MFF-056CS heating at 300S

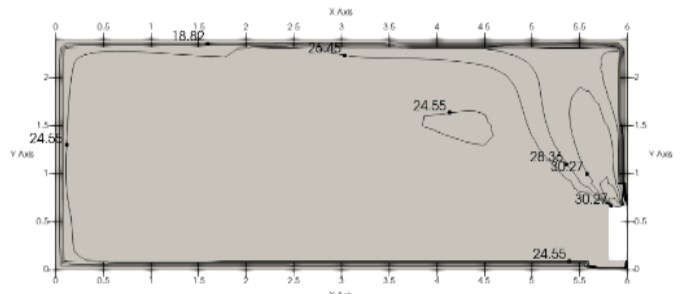

Figure 11.25: MFF-071CS cooling at 300S

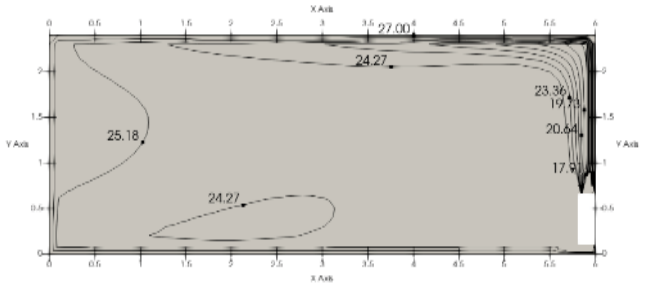

Figure 11.26: MFF-071CS heating at 300S

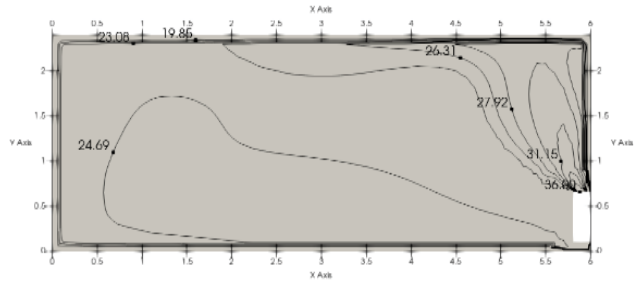

Figure 11.27: MFF-080CS cooling at 300S

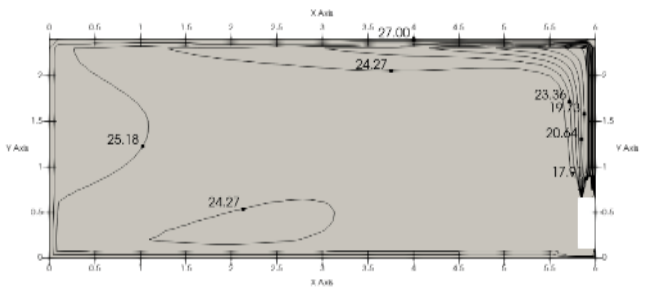
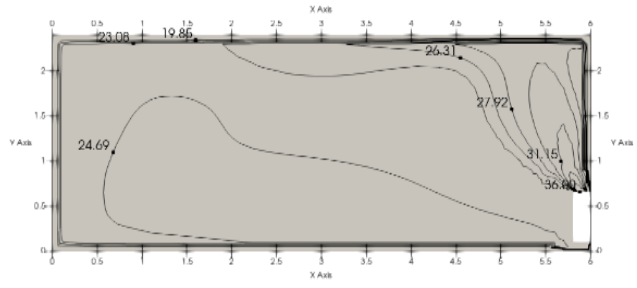

Figure 11.28: MFF-080CS heating at 300S





©Copyright 2023 Actron Engineering Pty Limited ABN 34 002767240. ®Registered Trade Marks of Actron Engineering Pty Limited.
ActronAir is constantly seeking ways to improve the design of its products. Therefore, specifications are subject to change without notice.