

ADVANCE AND AIRES Split Ducted Units

Troubleshooting Guide



Advance Model Numbers

R-410A

Outdoor	Indoor
CRV140S	EVV140AS
CRV160S	EVV160AS
CRV180S	EVV180AS
CRV160T	EVV210AS
CRV180T	EVV240AS
CRV210T	
CRV240T	

R-32

Outdoor	Indoor
CRV13AS	EVV13AS
CRV15AS	EVV15AS
CRV17AS	EVV17AS
CRV13AT	
CRV15AT	
CRV17AT	

Aires Model Numbers

Outdoor

CRS10AS	CRS13AT
CRS13AS	CRS15AT
CRS15AS	CRS17AT
CRS17AS	CRS20AT
	CRS23AT

Indoor

EVA10AS
EVA13AS
EVA15AS
EVA17AS
EVA20AS
EVA23AS

IMPORTANT NOTE:

Please read this manual carefully before installing or operating your air conditioning unit.



Table of Contents

01. General Troubleshooting	3
02. EC Fan Troubleshooting	4
03. Indoor Fan PWM and RPM Limits Table	6
03.01. Advance R-410A (Indoor Units paired to an Outdoor Unit with a UNO Board).....	6
03.02. Advance R-32 (Indoor Units paired to an Outdoor Unit with an UNO-Pro Board)	6
03.03. Aires (Indoor Units paired to an Outdoor Unit with an UNO-Pro Board).....	7
04. Component Troubleshooting	7
04.01. Testing Indoor Board.....	7
04.02. Expected Control Voltage On Communication Line - InZone Board (R-410A / R-32)	8
04.03. Expected Control Voltage On Communication Line - UNO Board Series (R-410A)	8
04.04. Expected Control Voltage On Communication Line - UNO Pro Board (R-32).....	9
04.05. Expected Voltage - InZone PCB To Indoor Fan.....	10
04.06. Compressor Winding Resistance.....	12
04.07. Condenser Fan Winding Resistance	13
04.08. Other Component Coil Resistances	15
04.09. Choke Reactor resistance.....	15
04.10. EEV Resistance	15
04.11. Temperature-Resistance Table For Sensors	16
04.12. High Pressure and Low Pressure Transducer	19
04.13. Advance Pressure-Voltage Table For Pressure Transducers	20
04.14. Aires Pressure-Voltage Table For Pressure Transducers	21
05. VSD Troubleshooting	22
05.01. Error Code Process.....	22
06. Fault Codes	23
06.01. Advance.....	23
06.02. Aires.....	26
07. Fault Code Troubleshooting	28

01. General Troubleshooting

Fault	Possible Causes	Remedies
The system does not start.	Built-in safety timers have been activated.	Allow up to 5 minutes for the system to start from when it is turned on.
	* A circuit breaker may have tripped.	* Check circuit breaker.
	The thermostat setpoint is incorrect.	Lower the set point on cooling or raise it on heating modes.
	The master wall control timer is set.	Check the wall control timer settings.
No airflow from the outlets.	During heating operation, the hot start function may have been activated.	During heating operation, the indoor fan is delayed for 30 seconds or until the indoor coil reaches 25°C (whichever occur first). This is to prevent cold drafts.
	The system may be operating in a defrost cycle during the heating cycle. (LR7 will display DEFROST . NEO will display Defrosting .)	This is normal operation during the defrost cycle to prevent cold air being blown into rooms.
Cooling/Heating is not sufficient.	The return air filter may be dirty.	Clean the return air filter.
	The outdoor unit may have an obstruction on the air inlet or outlet.	Ensure the air inlet and air outlet on the outdoor unit is not blocked. Check that the area around the outdoor unit is free from obstructions that may cause the airflow to recirculate.
	The airflow across the indoor coil may be outside of the operating range.	Reduce the total static pressure of the ductwork. For example increase duct sizes, reduce tight duct work bends or increase return air grille size.
	The heat load is greater than the installation design.	Perform a heat load analysis on the conditioned space. Turn any unused zones to the off position.
	Windows or doors are open.	Close windows and doors in conditioned areas.
	The outside temperature is beyond the air conditioner design conditions.	When the ambient temperature is expected to exceed the maximum design operating temperature, turn the system on as early as possible.
	The indoor fan setting may be set too low.	Change the fan speed to a higher setting. This will increase system capacity.
Steam emitted from outdoor unit.	The outdoor unit is going through a defrost cycle during the heating cycle.	This is normal during the defrost operation in cold ambient conditions.
	Condensation of water on the outdoor coil during heating operation.	This is normal during heating operation. Optional drip trays can be purchased to drain the excess water.
Set temperature cannot be adjusted.	The wall control set temperature limits are being exceeded.	Check the upper and lower temperature limits are set correctly.
Occasional hissing noise can be heard during the heating cycle.	This is the sound of the gas changing direction as the system goes through a defrost cycle.	This is a normal function of an air conditioner.
The compressor is operating but the system is not cooling.	You are in heating mode.	Check the temperature settings.
	The reversing valve has not switched between heating and cooling.	Test reversing valve.

* Available for Advance R-410A only

Fault	Possible Causes	Remedies
The outdoor coil keeps freezing over.	Faulty outdoor coil sensor	Check the sensor resistance.
	Jammed reversing valve.	Test the reversing valve operation.
	Obstruction on the outdoor unit.	Remove obstructions.
There is only one condenser fan working.	Faulty fan motor.	Test the fan motor resistance.
	*Faulty capacitor	*Test the capacitor microfarad reading.
	Faulty Outdoor PCB.	Test the PCB output voltage.
Compressor won't operate at 100% capacity.	You can adjust your wall control temperature so you have a large differential. This will operate the system at 100% until the temperature gets to within 4°C of the setpoint. Note: If the system operates under Anti Freeze or Overheat Protection the system will not operate at 100% capacity	Adjust the set point less then or greater than 4°C of the indoor temperature depending on mode of operation.
Odour in the conditioned space when the A/C is turned on.	Indoor unit has absorbed the conditioned space smells eg. cigarette, cooking, etc.	If this happens, we recommend you have the indoor unit washed by a technician. Consult the installer from whom you purchased the air conditioner.
	No P-Trap installed.	Re-pipe drain with a P-Trap.
	Dry P-Trap.	Contact the installer to carry out a general service and fill the P-Trap.

* Available for Advance R-410A only

02. EC Fan Troubleshooting

Fault	Sequence of Events	Possible Causes	Remedies
1. Auto Mode is not available.	When scrolling through fan speeds, Auto Mode is not selectable.	During commissioning, Self-Learn mode was not activated.	Carry out self learn mode. Refer LR7/LC7/NEO controller operation manual.
		Self learn mode failed during commissioning.	Ensure that the air is balanced correctly (static may be too high). Refer to Installation and Commissioning Guide-Indoor.
2. Airflow hunting during Auto and Self Learn Mode.	Indoor fan will intermittently "huff".	Excessive static in ductwork. Duct static has changed since performing a self-learn. Ducts deteriorate, dirty filter, change in duct layout.	Reduce static where possible. See installation guidelines on duct installation. Clean filter and re-perform self-learn.
3. Too much airflow when minimum zones are on.	Air is blowing too much when set to minimum zones.	Fan not set to Auto Mode.	Change fan setting to Auto Mode
		Poor air balance.	Carry out air balance and install manual dampers as required.
		Minimum duct and outlet sizes requirements not followed.	Check Installation and Commissioning Guide-Indoor and adjust / change if necessary.

Fault	Sequence of Events	Possible Causes	Remedies
4. Low airflow during AUTO Mode.	System produces reduced airflow on Auto mode when all or minimum zones are on.	System capacity has been designed to heat/cool only selected areas of the conditioned space at any one time.	Operate indoor fan on Low/ Med/High speed to achieve more airflow.
		Excessive static in ductwork.	Reduce static where possible. Review duct design with reference to Installation and Commissioning Guide-Indoor.
5. Indoor fan not changing speeds when in Auto Mode	When zones are switched on or off, airflow to active zones doesn't increase or decrease.	There is excessive static within the duct design of the active zones.	Review duct design with reference to Installation and Commissioning Guide-Indoor.
		The indoor PCB is not changing the fan PWM to adjust the fan speed.	Check the output PWM from indoor PCB. An increase in fan speed should result in a increase in the fan % PWM (duty cycle). Refer to table below test points expected voltages. To determine if the system may be suffering from excessive or insufficient static, check PWM & RPM values through the indoor unit dashboard on the Master Wall Controller: <ul style="list-style-type: none"> • If the RPM is at its maximum value, and the PWM has not reached its requested value, this indicates a high static. (Please refer to RPM Limits in Section 0.3) • When switching off zones, and there is little or no change in the RPM value, this indicates insufficient static within remaining active zones duct work.
6. HiS is displayed on the wall controller and Marginal Pass on NEO after a Self-Learn has been preformed (L Series Controller only).	System produces low airflow when AUTO mode is selected regardless of how many zones are open.	HiS is displayed on the wall control as a indication of very high static (>250Pa) in the connected return and supply duct which can further effect the supply air quantity during the auto mode. If there is too much static during self-learn, then the controller will automatically decrease the indoor fan speed until an acceptable static is achieved and the self-learn can be completed with reduced airflow.	Reduce static where possible. Review duct design with reference to Installation and Commissioning Guide - Indoor . Once static has been reduced perform Self-Learn again.

03. Indoor Fan PWM and RPM Limits Table

03.01. Advance R-410A (Indoor Units paired to an Outdoor Unit with a UNO Board)

Unit Model	PWM % (Approx)		
	Low	Medium	High
EVV140S	35	47	60
EVV160S	42	58	77
EVV180S	50	69	99
EVV210S	43	61	82
EVV240S	44	62	84

Unit Model	RPM Limits		
	Low	Medium	High
EVV140S	1150	1290	1390
EVV160S	1150	1290	1390
EVV180S	1150	1290	1390
EVV210S	1150	1350	1500
EVV240S	1150	1350	1500

03.02. Advance R-32 (Indoor Units paired to an Outdoor Unit with an UNO-Pro Board)

Unit Model	PWM % (Approx)		
	Low	Medium	High
EVV13AS	40	50	64
EVV15AS	52	64	73
EVV17AS	57	73	99

Unit Model	RPM Limits		
	Low	Medium	High
EVV13AS	1380	1380	1380
EVV15AS	1380	1380	1380
EVV17AS	1380	1380	1380

03.03. Aires (Indoor Units paired to an Outdoor Unit with an UNO-Pro Board)

Unit Model	PWM % (Approx)		
	Low	Medium	High
EVA10AS	40	55	72
EVA13AS	40	50	64
EVA15AS	52	64	84
EVA17AS	57	73	99
EVA20AS	50	68	90
EVA23AS	45	65	89

Unit Model	RPM Limits		
	Low	Medium	High
EVA10AS EVA13AS EVA15AS EVA17AS EVA20AS EVA23AS	1380	1380	1380

04. Component Troubleshooting

04.01. Testing Indoor Board

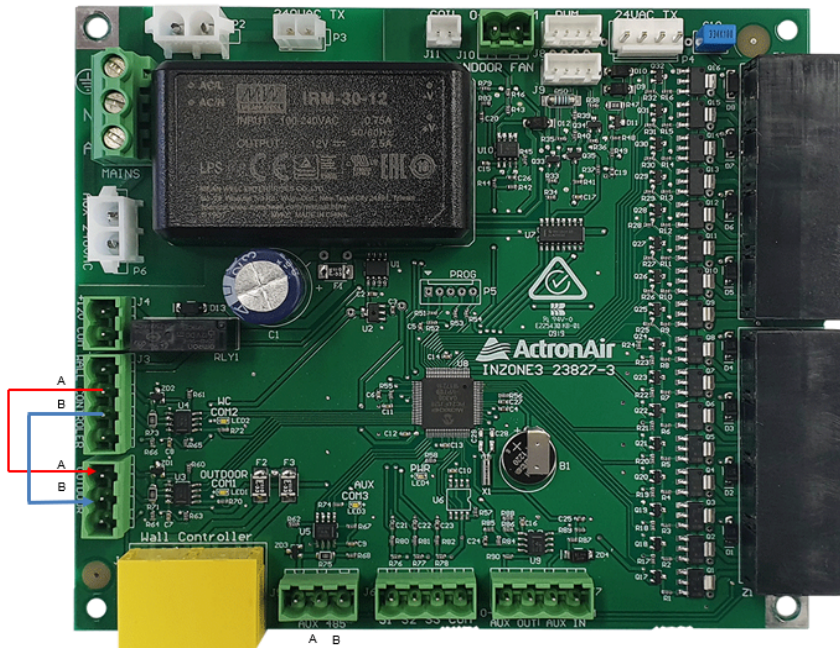

1. Disconnect wires from the Wall Control Communication and Outdoor Communication plugs into indoor board
2. Loop the "A" terminal from the Wall Control communication plug to the "A" terminal on the Outdoor Communication Plug
3. Loop the "B" Terminal from the Wall Control communication plug to the "B" terminal on the Outdoor Communication Plug
4. Power the board and if the WCCOM2 LED flashes and the OUTDOORCOM1 flashes then the indoor board is communicating.

04.02. Expected Control Voltage On Communication Line - InZone Board (R-410A / R-32)

NOTES

- If COM1 (LED1) and COM2 (LED2) are blinking, communication is occurring.
- * Voltage sending between A-G and B-G are fluctuating, this means communication is occurring.
- Prior to measuring the control voltage ensure communication wires are properly connected to the CPU board.

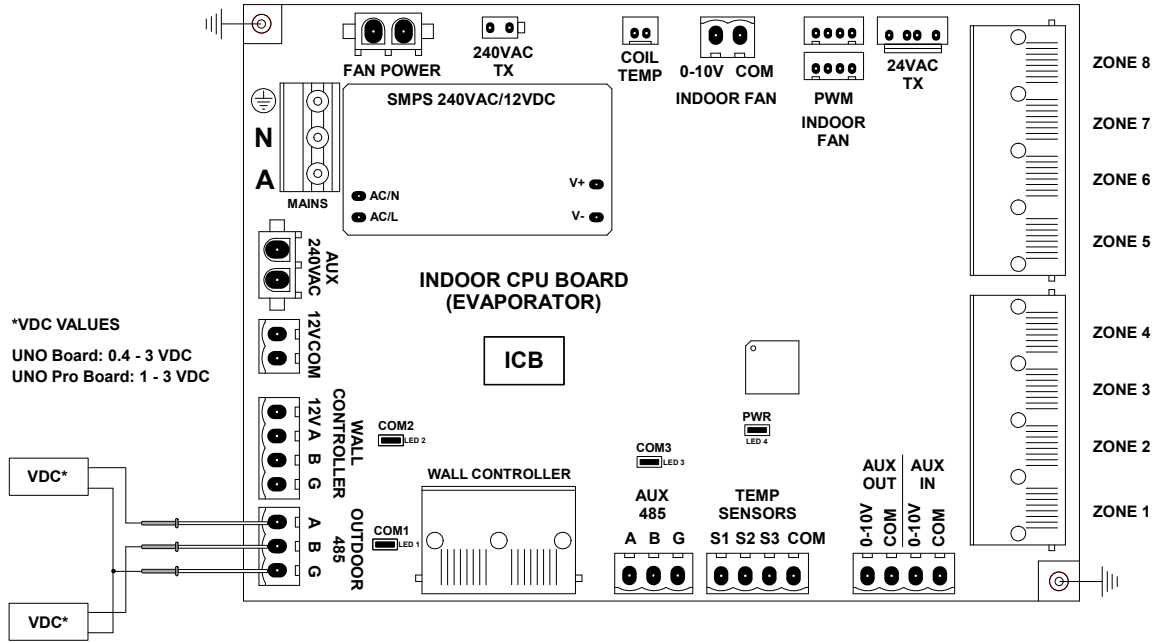

04.03. Expected Control Voltage On Communication Line - UNO Board Series (R-410A)

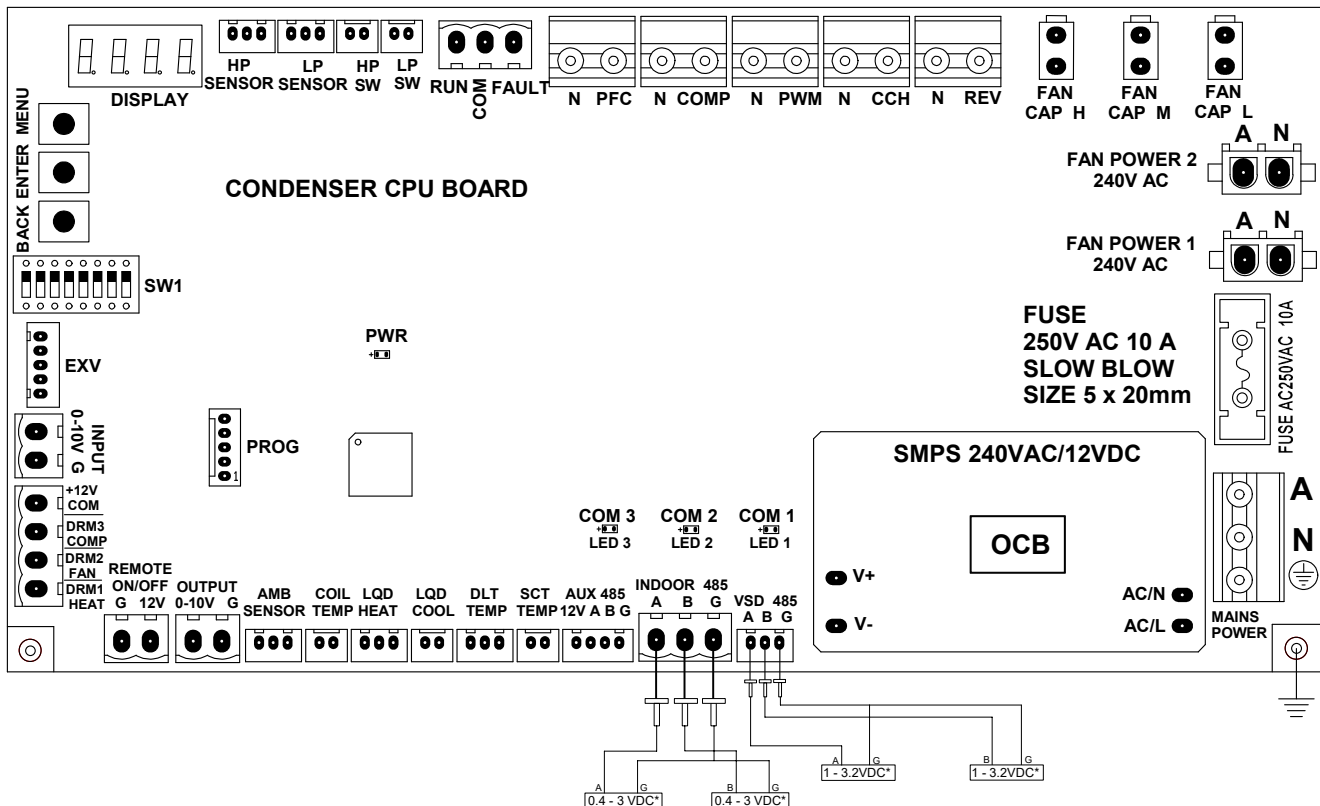

04.04. Expected Control Voltage On Communication Line - UNO Pro Board (R-32)

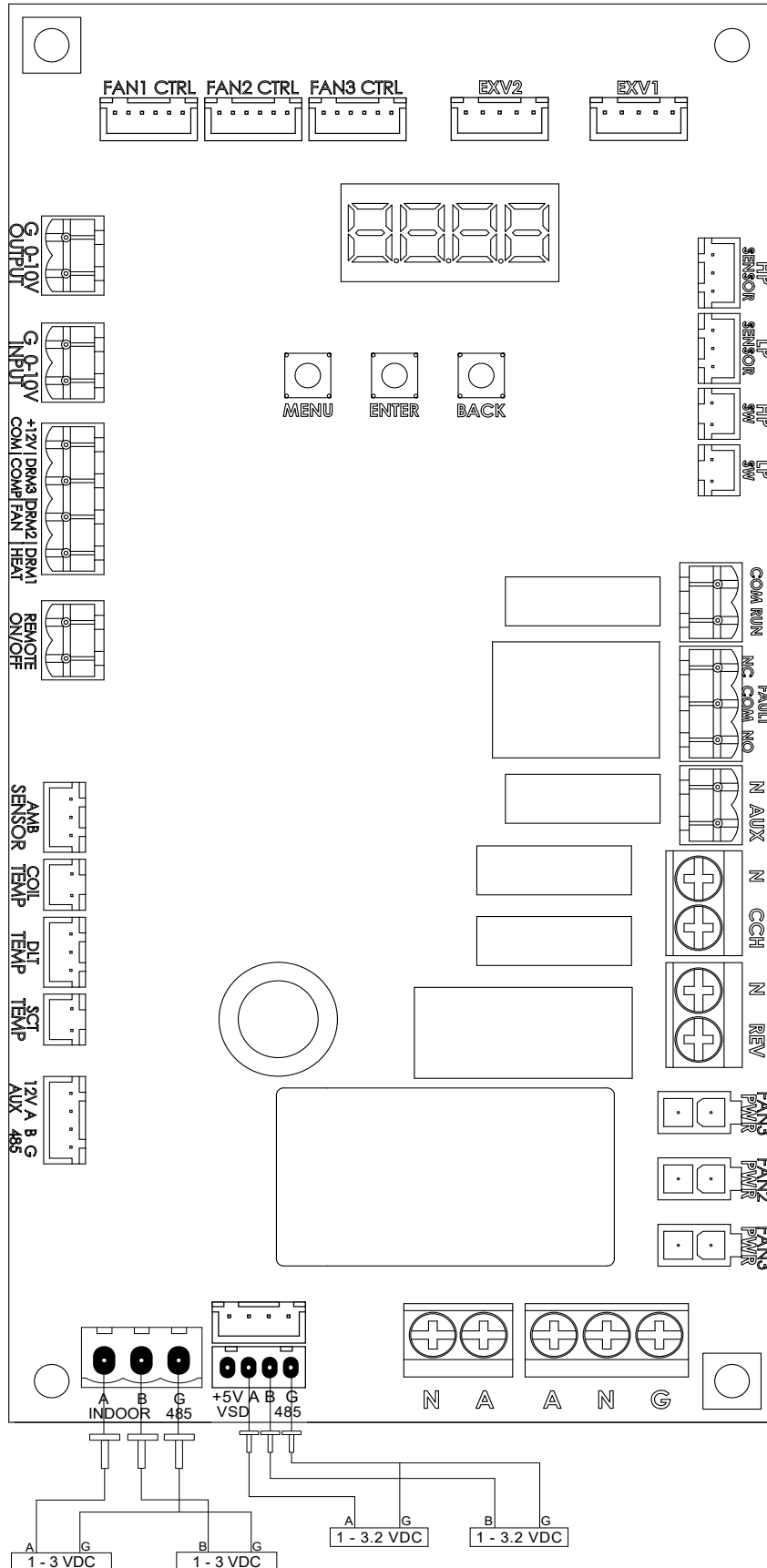

04.05. Expected Voltage - InZone PCB To Indoor Fan

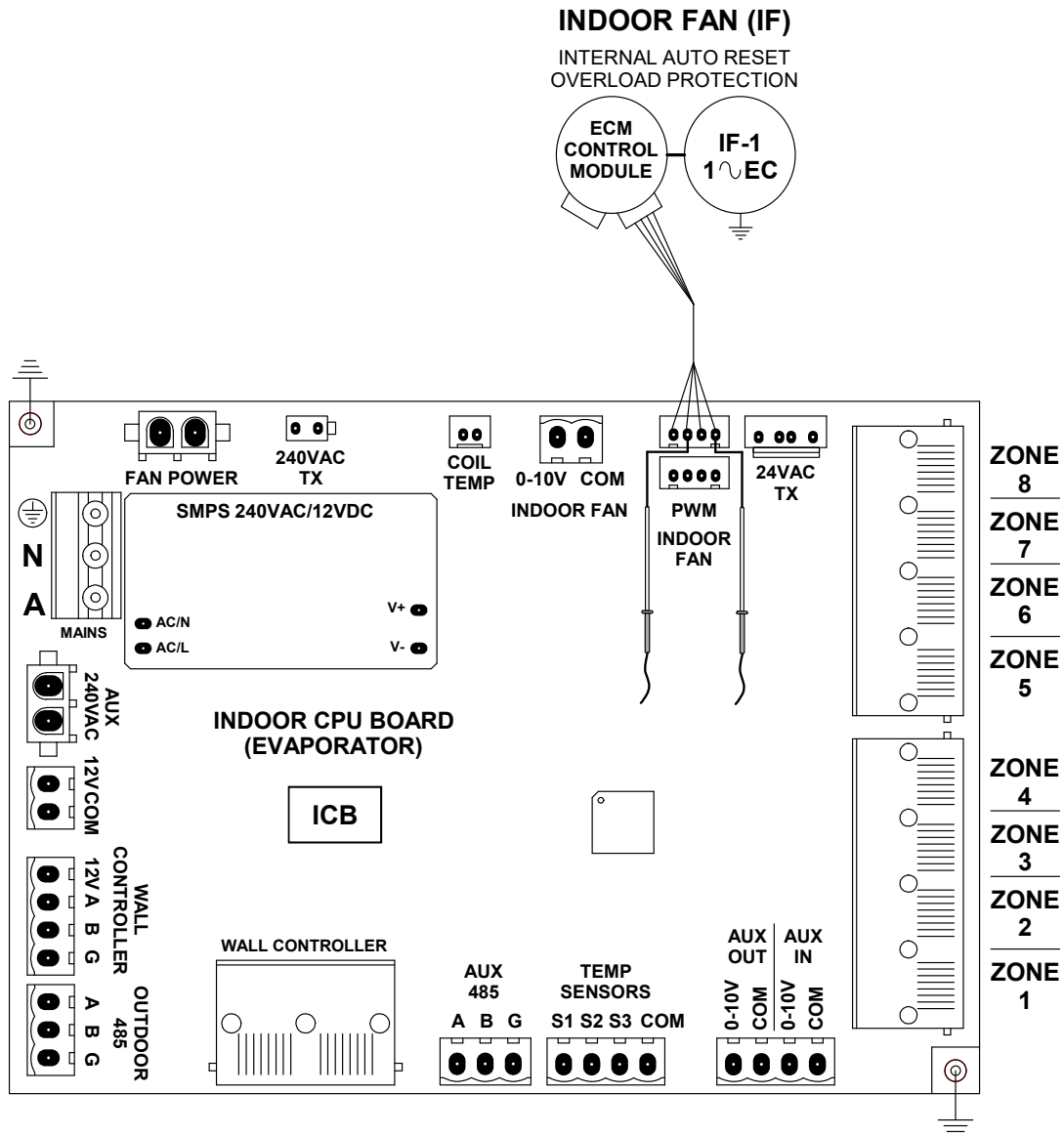

NOTE

Please refer to the tables in the following steps for the color codes of the motor cables.

Step 1.

1. Measure the Indoor Fan on/off signal between Pin 1 and 3 using the wire colors shown in the table below.

Unit Model	On Signal is 12VDC signal		Off Signal is +0VDC signal	
	Regal Fan	Elgee Fan	Regal Fan	Elgee Fan
EVA20-23AS / EVV210-240S	Red and Blue	-	Red and Blue	-
EVV13-17AS EVV140-180S EVA10AS / EVA13-17AS	-	Yellow and Black	-	Yellow and Black

Step 2.

1. Set the tester to measure duty cycle $\square\square\square$.
2. Set the indoor fan to a fixed speed eg High & turn all zones on.
3. Measure the Indoor Fan on/off signal between Pin 3 and 4 using the wire colors shown in the table below.

Unit Model	Regal Fan	Elgee Fan
EVA20-23AS / EVV210-240S	Blue and Yellow	-
EVV13-17AS EVV140-180S EVA10AS / EVA13-17AS	-	Black and Red

4. Change fan speed and check for any changes in readings.
5. Compare the duty cycle output to the expected PWM for each model.

NOTE

Duty cycle cannot be tested in voltage. A voltage on the PWM line indicates a Duty Cycle is present.

04.06. Compressor Winding Resistance

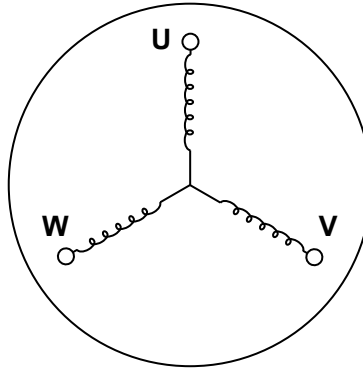

COMPRESSOR WINDINGS
SINGLE PHASE

	Unit Model	Compressor Part Number/Model	Rating Of Compressor Windings (Ω)*		
			U - V	V - W	U - W
Advance R-410A	CRV140S	1560-476	0.338	0.338	0.338
	CRV160S				
	CRV180S				
	CRV160T	1560-474	0.521	0.521	0.521
	CRV180T				
	CRV210T	1560-475	0.610	0.610	0.610
	CRV240T				
Advance R-32	CRV13AS	1560-477	0.345	0.345	0.345
	CRV15AS				
	CRV17AS				
	CRV13AT	1560-478	0.658	0.658	0.658
	CRV15AT				
	CRV17AT				
Aires	CRS10AS	CRS1002	1.062	1.062	1.062
	CRS13AS	CRS1302	0.63	0.63	0.63
	CRS15AS				
	CRS17AS				
	CRS13AT				
	CRS15AT				
	CRS17AT				
	CRS20AT	CRS2311	0.35	0.35	0.35
	CRS23AT				

*Resistance value at 25 °C ambient Temperature

04.07. Condenser Fan Winding Resistance

04.07.01. Advance R-410A (Three Speed Motor)

Unit Model	Fan Part Number	Rating Of Fan Windings (Ω)*	
CRV140S CRV160S CRV180S CRV160T CRV180T	2505-141	Black and Blue	97
		Blue and Brown	143
		Black and Brown	240
		Any colour and earth	Open circuit
CRV210T CRV240T	2505-130	Brown and Black	68.2
		Brown and Blue	38.6
		Black and Blue	30.1
		Any colour and earth	Open circuit
		Any colour and either Gray	Open circuit

*Resistance value at 25°C ambient Temperature

04.07.02. Advance R-32 (Variable Speed Motor)

Unit Model	Fan Part Number	Rating Of Fan Windings (Ω)*
CRV13AS	2505-143	N/A
CRV15AS		
CRV17AS		
CRV13AT		N/A
CRV15AT		
CRV17AT		

*Resistance value at 25°C ambient Temperature

04.07.03. Aires (Variable Speed Motor)

Unit Model	Fan Part Number	Rating Of Fan Windings (Ω)*			
		Black - Red	Black - White	Black - Yellow	Black - Blue
CRS10AS	CRS1020	6.5 - 8.5K Ω	3.5 - 5.5K Ω	0.18 - 0.22M Ω	6.5 - 10K Ω
CRS13AS CRS13AT	CRS1319				
CRS15AS CRS15AT	CRS1517				
CRS17AS CRS17AT					
CRS20AT	CRS2348				
CRS23AT					

*Resistance value at 25°C ambient Temperature

04.07.04. Condenser Fan Voltage Testing

Drawings below are for illustration purposes only. Please refer to the actual drawing of the motor used.

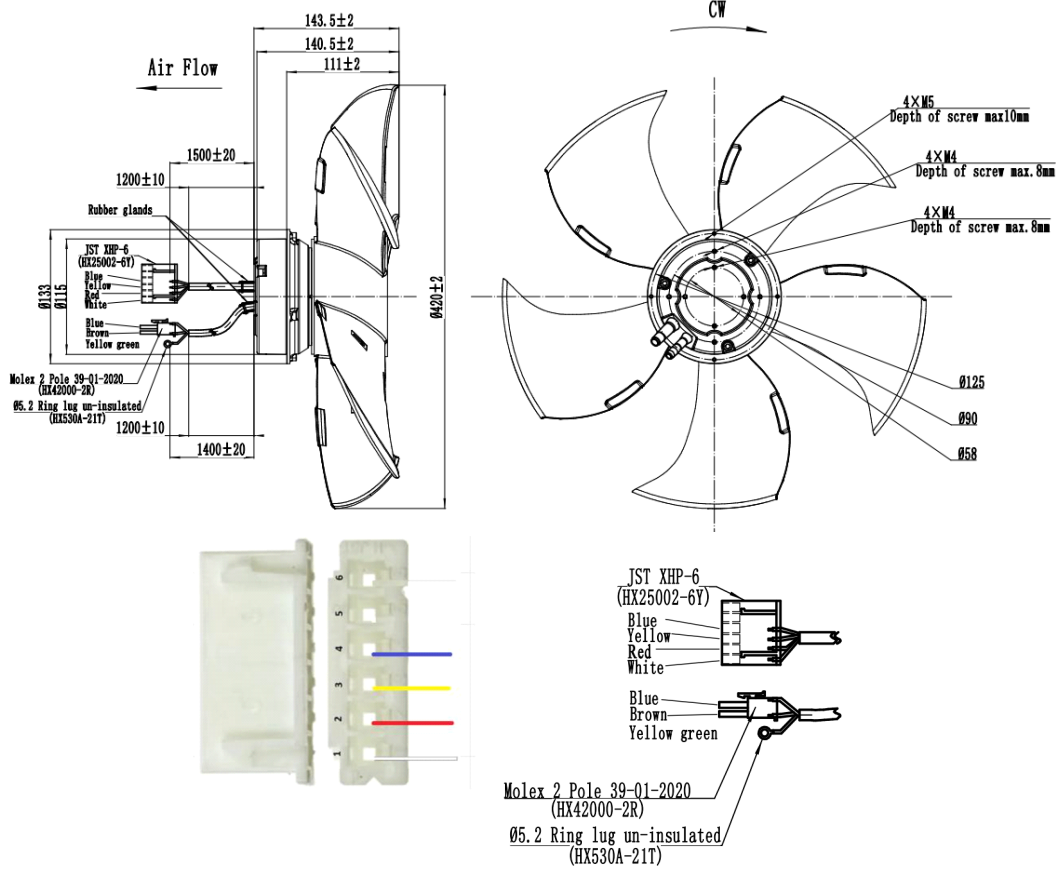

ADVANCE R-32

Control Voltage	Fan Data Wire Colour	Fan Data Output	PCB JST XHP-6 Pin
-	White	Fan Feedback	1
-	Red	+10VDC Supply	2
2 - 10 VDC	Yellow	0 - 10 VDC	3
-	Blue	0V Ground	4
-	-	-	5
-	-	-	6
1.5 - 10 VDC	Yellow - Blue	UNO Pro to Fan	

AIRES

Control Voltage	Fan Data Wire Colour	Fan Data Output	PCB JST XHP-6 Pin
310VDC	Red	Vm	1
-	-	-	2
-	Black	Ground	3
15VDC Run Signal	White	Vcc	4
0 - 6.5VDC	Yellow	Vsp	5
-	Blue	RPM Feedback	6

04.08. Other Component Coil Resistances

Component Name	Resistance Value (K Ω)*
Reversing valve	2.03
Crankcase Heater (For Advance R-410A and R-32 only)	1.56

*Resistance value at 25°C Ambient Temperature

04.09. Choke Reactor resistance

	Unit Model	Resistance Between Wires / Terminals (Ω)*
Advance R-410A	CRV140S	16 - 18
	CRV160S	16 - 18
	CRV180S	16 - 18
	CRV160T	16 - 18
	CRV180T	16 - 18
	CRV210T	16 - 18
	CRV240T	16 - 18
Advance R-32	CRV13AS	2.9
	CRV15AS	2.9
	CRV17AS	2.9
	CRV13AT	16 - 18
	CRV15AT	16 - 18
	CRV17AT	16 - 18
Aires	CRS10AS	70m Ω
	CRS13AS	50m Ω
	CRS15AS	50m Ω
	CRS17AS	50m Ω
	CRS13AT	70m Ω
	CRS15AT	70m Ω
	CRS17AT	70m Ω
	CRS20AT	70m Ω
	CRS23AT	70m Ω

*Resistance value at 25°C ambient Temperature

04.10. EEV Resistance

Resistance Between Wires	Resistance Value (Ω)*
Orange – Grey	46 \pm 3 Ω
Red – Grey	46 \pm 3 Ω
Yellow – Grey	46 \pm 3 Ω
Black – Grey	46 \pm 3 Ω

*Resistance value at 20°C Ambient Temperature

04.11. Temperature-Resistance Table For Sensors

Temp (°C)	Ambient/Outdoor Coil/ Indoor Coil/Suction Temperature Sensor	Discharge Line Temperature Sensor
	Resistance (KΩ)	Resistance (KΩ)
-20	77.5	1053.9
-19	73.5	992.1
-18	69.7	933.0
-17	66.1	878.0
-16	62.8	827.0
-15	59.6	779.6
-14	56.6	734.7
-13	53.8	693.2
-12	51.2	654.0
-11	48.7	617.1
-10	46.3	582.5
-9	44.1	550.6
-8	42.0	520.2
-7	40.0	491.8
-6	38.1	465.2
-5	36.3	440.4
-4	34.6	416.9
-3	33.0	394.8
-2	31.5	374.1
-1	30.1	354.7
0	28.7	336.4
1	27.4	319.0
2	26.2	302.7
3	25.0	287.3
4	23.9	273.0
5	22.9	259.2
6	21.9	246.4
7	21.0	234.3
8	20.1	222.8
9	19.2	212.0
10	18.4	201.8
11	17.6	192.1
12	16.9	183.0
13	16.2	174.3
14	15.5	166.1
15	14.9	158.4
16	14.3	151.1
17	13.7	144.1
18	13.2	137.5
19	12.7	131.3

Temp (°C)	Ambient/Outdoor Coil/ Indoor Coil/Suction Temperature Sensor	Discharge Line Temperature Sensor
	Resistance (KΩ)	Resistance (KΩ)
20	12.2	125.4
21	11.7	119.7
22	11.2	114.4
23	10.8	109.4
24	10.4	104.6
25	10.0	100.0
26	9.6	95.7
27	9.3	91.6
28	8.9	87.6
29	8.6	83.9
30	8.3	80.4
31	8.0	77.0
32	7.7	73.8
33	7.4	70.7
34	7.1	67.8
35	6.9	65.1
36	6.6	62.4
37	6.4	59.9
38	6.2	57.5
39	6.0	55.2
40	5.8	53.0
41	5.6	50.9
42	5.4	48.9
43	5.2	47.0
44	5.0	45.2
45	4.8	43.5
46	4.7	41.8
47	4.5	40.2
48	4.4	38.7
49	4.2	37.3
50	4.1	35.9
51	4.0	34.6
52	3.8	33.3
53	3.7	32.1
54	3.6	30.9
55	3.5	29.8
56	3.4	28.7
57	3.3	27.7
58	3.2	26.7
59	3.1	25.8

Temp (°C)	Ambient/Outdoor Coil/ Indoor Coil/Suction Temperature Sensor	Discharge Line Temperature Sensor
	Resistance (KΩ)	Resistance (KΩ)
60	3.0	24.9
61	2.9	24.0
62	2.8	23.2
63	2.7	22.4
64	2.6	21.6
65	2.6	20.9
66	2.5	20.2
67	2.4	19.5
68	2.3	18.8
69	2.3	18.2
70	2.2	17.6
71	2.1	17.0
72	2.1	16.5
73	2.0	15.9
74	2.0	15.4
75	1.9	14.9
76	1.9	14.4
77	1.8	14.0
78	1.8	13.5
79	1.7	13.1
80	1.7	12.7
81	1.6	12.3
82	1.6	11.9
83	1.5	11.6
84	1.5	11.2
85	1.5	10.9
86	1.4	10.5
87	1.4	10.2
88	1.3	9.9
89	1.3	9.6
90	1.3	9.3
91	1.2	9.1
92	1.2	8.8
93	1.2	8.5
94	1.1	8.3
95	1.1	8.1
96	1.1	7.8
97	1.1	7.6
98	1.0	7.4
99	1.0	7.2

Temp (°C)	Ambient/Outdoor Coil/ Indoor Coil/Suction Temperature Sensor	Discharge Line Temperature Sensor
	Resistance (KΩ)	Resistance (KΩ)
100	1.0	7.0
101	1.0	6.8
102	0.9	6.6
103	0.9	6.4
104	0.9	6.2
105	0.9	6.1
106	0.9	5.9
107	0.8	5.7
108	0.8	5.6
109	0.8	5.4
110	0.8	5.3
111	0.8	5.2
112	0.7	5.0
113	0.7	4.9
114	0.7	4.8
115	0.7	4.6
116	0.7	4.5
117	0.7	4.4
118	0.6	4.3
119	0.6	4.2
120	0.6	4.1

04.12. High Pressure and Low Pressure Transducer

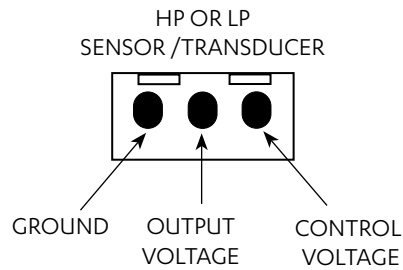

Control Voltage	5.0 ± 0.2 VDC
Output Voltage	0.5 TO 4.5 VDC

04.13. Advance Pressure-Voltage Table For Pressure Transducers

High Pressure Transducer		Low Pressure Transducer	
Pressure (Kpa)	Output Voltage (VDC)	Pressure (Kpa)	Output Voltage (VDC)
0	0.5	0	0.5
125	0.6	50	0.6
375	0.8	150	0.8
625	1	250	1
875	1.2	350	1.2
1125	1.4	450	1.4
1375	1.6	550	1.6
1625	1.8	650	1.8
1875	2	750	2
2125	2.2	850	2.2
2375	2.4	950	2.4
2625	2.6	1050	2.6
2875	2.8	1150	2.8
3125	3	1250	3
3375	3.2	1350	3.2
3625	3.4	1450	3.4
3875	3.6	1550	3.6
4125	3.8	1650	3.8
4375	4	1750	4
4625	4.2	1850	4.2
4875	4.4	1950	4.4
5125	4.6	2050	4.6
5375	4.8	2150	4.8
5625	5	2250	5

04.14. Aires Pressure-Voltage Table For Pressure Transducers

High Pressure Transducer		Low Pressure Transducer	
Pressure (Kpa)	Output Voltage (VDC)	Pressure (Kpa)	Output Voltage (VDC)
0	0.5	0	0.5
115	0.6	50	0.6
345	0.8	150	0.8
575	1	250	1
805	1.2	350	1.2
1035	1.4	450	1.4
1265	1.6	550	1.6
1495	1.8	650	1.8
1725	2	750	2
1955	2.2	850	2.2
2185	2.4	950	2.4
2415	2.6	1050	2.6
2645	2.8	1150	2.8
2875	3	1250	3
3105	3.2	1350	3.2
3335	3.4	1450	3.4
3565	3.6	1550	3.6
3795	3.8	1650	3.8
4025	4	1750	4
4255	4.2	1850	4.2
4485	4.4	1950	4.4
4600	4.5	2000	4.5

05. VSD Troubleshooting

05.01. Error Code Process

Compressor Will Not Start Before Error Shows

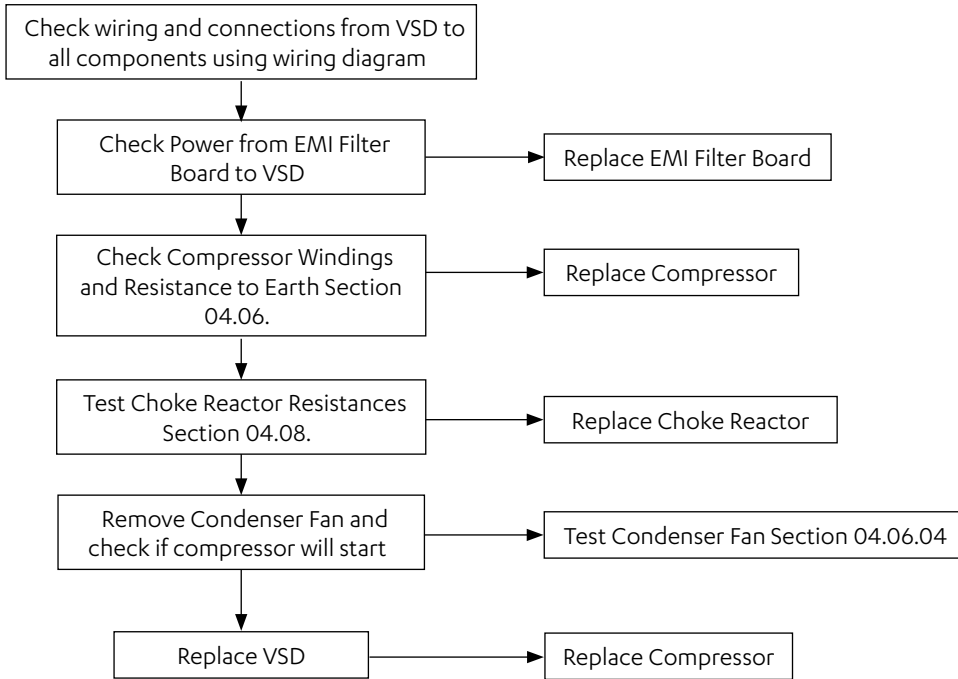

Compressor Runs or Starts Before Error Shows

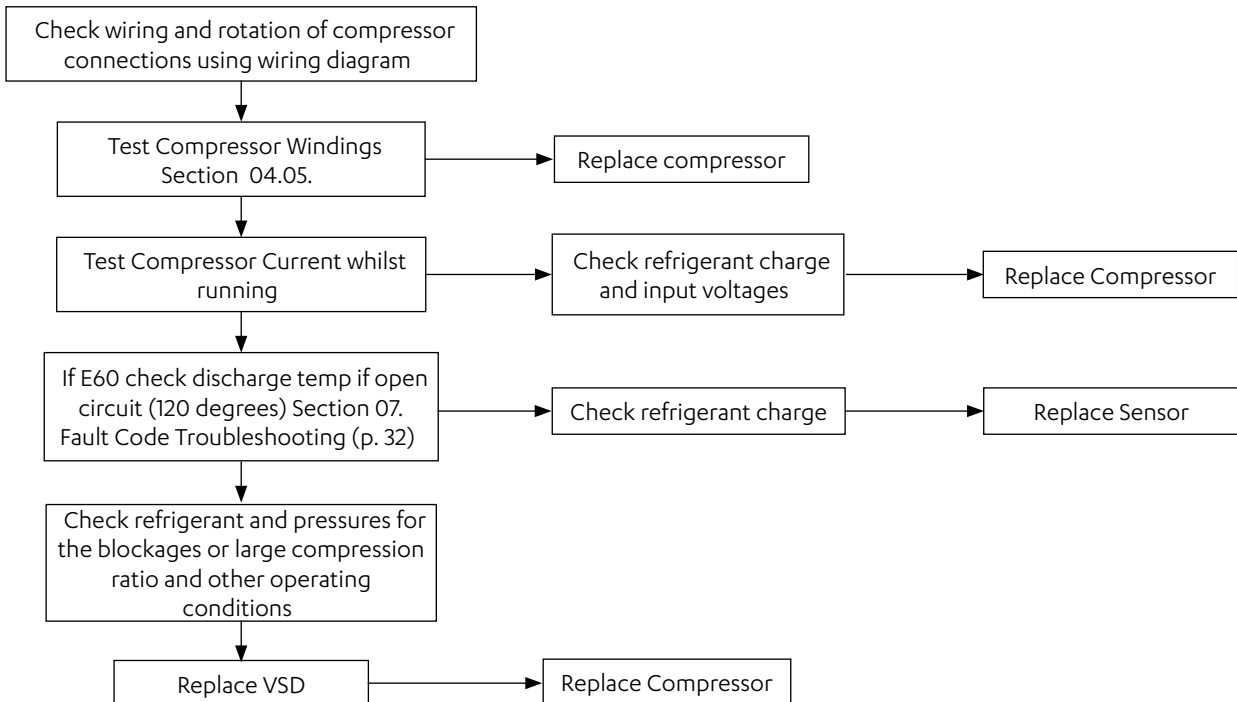

06. Fault Codes

06.01. Advance

NEO Wall Controller	LR7-1 /LC7-2 Wall Controller	Outdoor Unit CPU	Category / Source	Function / Fault
E01	E01	E01	IDU	Indoor Fan RPM Feedback Error
E03	E03	E03	IDU	Indoor Room Temp. Sensor Error (Open or short circuit)
E04	E04	E04	IDU	Indoor Coil IN Temp. Sensor Error (open or short circuit)
E06	E06	E06	IDU	High Discharge Temp. (Discharge Temp exceeded 120°C)
E07	E07	E07	ODU	Outdoor Coil Temp. Sensor Error (Open or short circuit)
E08	E08	E08	ODU	Discharge Temp. Sensor Error (Open or short circuit)
E09	E09	E09	ODU	LP Switch Tripped
E10	E10	E10	ODU	LP Sensor Error (Open/short circuit)
E11	E11	E11	ODU	HP Switch Tripped
E12	E12	E12	ODU	HP Sensor Error (Open/short circuit)
E13*	E13*	E13*	ODU	VSD HSP Connector (Jumper Pin Missing)
E13	E13	E13	ODU	Other Drive Errors
E15	E15	E15	ODU / VSD	Communication Error Between ODU to VSD
E18	E18	E18	ODU	Suction Temp. Sensor Error (Open/short circuit)
E22	E22	E22	ODU	Ambient Temp. Sensor Error (Open/short circuit)
E26	E26	E26	VSD	VSD Supply Over Current
E27	E27	E27	VSD	VSD Supply Over Voltage
E28	E28	E28	VSD	VSD Temperature High
E29	E29	E29	VSD	VSD Low Supply Voltage
E30	E30	E30	VSD	VSD Trip Lock
E41	E41	E41	VSD	VSD DC Link Voltage Low
E42	E42	E42	ODU	Envelope Protection Error (Extreme Low Evaporating Pressure)
E43	E43	E43	ODU	Envelope Protection Error (High compression ratio)
E44	E44	E44	ODU	Envelope Protection Error (High condensing pressure)
E45	E45	E45	ODU	Envelope Protection Error (Low compression ratio)
E47	E47	E47	ODU	Compressor Torque Limit Error
E50	E50	E50	ODU	Outdoor Board Configuration Error
E51	E51	E51	IDU / ODU	Communication Error Between Outdoor to Indoor Unit
E52	E52	E52	CMI / ODU	Communication Error Between Indoor Unit to Wall controller
E55	E55	E55	ODU	Communication Error Between BMS to ODU
E56	E56	E56	VSD	No Master Wall Controller Detected
E60	E60	E60	VSD	VSD Compressor Phase Over Current

* Applicable only for Advance R-410A (Uno Board)

NEO Wall Controller	LR7-1/LC7-2 Wall Controller	Outdoor Unit CPU	Category / Source	Function / Fault
E61	E61	E61	VSD	VSD Compressor Loss of Phase
E62	E62	E62	VSD	VSD DC Bus Over Voltage
E63	E63	E63	VSD	VSD DC Bus Under Voltage
E64	E64	E64	VSD	VSD Compressor Loss of Rotor
E65	E65	E65	VSD	VSD Compressor U Phase Current Sensor Fault
E66*	E66*	E66*	VSD	VSD AC Voltage Imbalance / AC Input Loss of Phase
E67*	E67*	E67*	VSD	VSD Inverter De-saturation
E68	E68	E68	VSD	VSD Compressor V Phase Current Sensor Fault
E69	E69	E69	VSD	VSD PFC-IGBT Over Temp
E70	E70	E70	VSD	VSD Lost Rotor Position
E71	E71	E71	VSD	VSD Motor Temp Sensor Error
E72	E72	E72	VSD	VSD Precharge Relay Open
E73	E73	E73	VSD	VSD Compressor W Phase Current Sensor Fault
E74	E74	E74	VSD	VSD IGBT Over Current / Choke wiring or failure
E75	E75	E75	VSD	VSD Compressor Phase Current Fold Back Timeout
E76	E76	E76	VSD	VSD Power Module Temp. Fold Back Timeout
E77	E77	E77	VSD	VSD AC Input Current Fold Back Timeout
E78	E78	E78	VSD	VSD PFC-IGBT Temp. Low
E79	E79	E79	VSD	VSD IPM Desat Protection/Compressor HW Over Current
E80	E80	E80	VSD	VSD Motor Temp High
E81	E81	E81	VSD	VSD Board Temp High
E82	E82	E82	VSD	VSD Power Module Temp High
E83	E83	E83	VSD	VSD PFC-IGBT Temp High
E84	E84	E84	VSD	Communication Error in VSD Between DSP to PFC
E85	E85	E85	VSD	Communication Error in VSD Between Comms to DSP
E86	E86	E86	VSD	Compressor Phase Current Imbalance
E87	E87	E87	VSD	VSD 3 Phase PFC Current Imbalance
E88**	E88**	E88**	VSD	VSD Micro Electronic or EEPROM Error
E89	E89	E89	VSD	VSD Motor Over Speed
E90	E90	E90	VSD	VSD Compressor Model Configuration Error
E91	E91	E91	VSD	VSD Inverter Temp Imbalance
E92	E92	E92	VSD	VSD PFC Temp Imbalance

* Applicable only for Advance R-410A (Uno Board)

** Applicable only for Advance R-32 (Uno Pro Board)

PFC: Power Factor Correction

IGBT: Insulated-Gate Bipolar Transistor

DSP: Digital Signal Processor

NEO Wall Controller	LR7-1 /LC7-2 Wall Controller	Outdoor Unit CPU	Category / Source	Function / Fault
E93	E93	E93	VSD	VSD Motor Temp Low
E94	E94	E94	VSD	VSD Board Temp Low
E95	E95	E95	VSD	VSD Power Module Temp Low or Sensor (Open or short circuit)
E96	E96	E96	VSD	VSD PFC-IGBT Temp Low
E97	E97	E97	VSD	VSD Comms ADC Failure
E98	E98	E98	VSD	VSD PFC / Input Current Sensor Fault
E99	E99	E99	VSD	VSD Compressor Overload
E100	E100	E100	VSD	VSD PFC Hardware Over Current
E101	E101	E101	VSD	VSD PFC Software Over Current
E102	E102	E102	VSD	VSD PFC Over Voltage
E103**	E103**	E103**	VSD	VSD Power Module Temp Low or Sensor Open fault
E104**	E104**	E104**	VSD	VSD Fault Limit Lockout

** Applicable only for Advance R-32 (Uno Pro Board)

PFC: Power Factor Correction

IGBT: Insulated-Gate Bipolar Transistor

ADC: Analog to Digital Converter

06.02. Aires

NEO Wall Controller	LR7-1 /LC7-2 Wall Controller	Outdoor Unit CPU	Category / Source	Function / Fault
E01	E01	E01	IDU	Indoor Fan RPM Feedback Error
E03	E03	E03	IDU	Indoor Room Temp. Sensor Error (Open or short circuit)
E04	E04	E04	IDU	Indoor Coil In Temp. Sensor Error (open or short circuit)
E06	E06	E06	IDU	High Discharge Temp. (Discharge Temp exceeded 138°C)
E07	E07	E07	ODU	Outdoor Coil Temp. Sensor Error (Open or short circuit)
E08	E08	E08	ODU	Discharge Temp. Sensor Error (Open or short circuit)
E09	E09	E09	ODU	LP Switch Tripped
E10	E10	E10	ODU	LP Sensor Error (Open/short circuit)
E11	E11	E11	ODU	HP Switch Tripped
E12	E12	E12	ODU	HP Sensor Error (Open/short circuit)
E13	E13	E13	ODU	Other Drive Errors
E15	E15	E15	ODU / VSD	VSD - ODU Modbus Communication Lost
E18	E18	E18	ODU	Suction Temp. Sensor Error (Open/short circuit)
E22	E22	E22	ODU	Ambient Temp. Sensor Error (Open/short circuit)
E26	E26	E26	VSD	VSD Input Over Current
E27	E27	E27	VSD	VSD Input Over Voltage
E28	E28	E28	VSD	VSD Power Module Over Temp
E29	E29	E29	VSD	VSD Input Under Voltage
E30	E30	E30	VSD	VSD Trip Lock
E41	E41	E41	VSD	VSD DC Voltage Low
E42	E42	E42	ODU	Envelope Protection Error (Extreme Low Evaporating Pressure)
E43	E43	E43	ODU	Envelope Protection Error (High compression ratio)
E44	E44	E44	ODU	Envelope Protection Error (High condensing pressure)
E45	E45	E45	ODU	Envelope Protection Error (Low compression ratio)
E47	E47	E47	ODU	Compressor Torque Limit Error
E50	E50	E50	ODU	Outdoor Board Configuration Error
E51	E51	E51	IDU / ODU	Communication Error Between Outdoor to Indoor Unit
E52	E52	E52	IDU	Communication Error Between Indoor Unit to Wall controller
E55	E55	E55	ODU	Communication Error Between BMS to ODU
E56	E56	E56	VSD	No Master Wall Controller Detected
E60	E60	E60	VSD	VSD Compressor Phase Over Current
E61	E61	E61	VSD	VSD Compressor Loss of Output Phase
E62	E62	E62	VSD	VSD DC Bus Over Voltage
E63	E63	E63	VSD	VSD DC Bus Under Voltage

NEO Wall Controller	LR7-1/LC7-2 Wall Controller	Outdoor Unit CPU	Category / Source	Function / Fault
E65	E65	E65	VSD	Compressor Phase Loss Fault
E69	E69	E69	VSD	VSD PFC-IGBT Over Temp
E70	E70	E70	VSD	VSD Lost Rotor Position
E71	E71	E71	VSD	VSD Motor Temp Sensor Error
E72	E72	E72	VSD	VSD Precharge Relay Open
E73	E73	E73	VSD	VSD Compressor W Phase Current Sensor Fault
E74	E74	E74	VSD	VSD IGBT Over Current
E75	E75	E75	VSD	VSD Compressor Phase Current Fold Back Timeout
E76	E76	E76	VSD	VSD Power Module Temp. Fold Back Timeout
E77	E77	E77	VSD	VSD AC Input Current Fold Back Timeout
E78	E78	E78	VSD	VSD PFC-IGBT Temp. Low
E79	E79	E79	VSD	VSD IPM Modular Over Current
E80	E80	E80	VSD	VSD Motor Temp High
E81	E81	E81	VSD	VSD Board Temp High
E82	E82	E82	VSD	VSD Power Module Temp High
E83	E83	E83	VSD	VSD PFC-IGBT Temp High
E84	E84	E84	VSD	VSD Communication Lost Between DSP to PFC
E85	E85	E85	VSD	VSD Communication Lost Between Comms to DSP
E88	E88	E88	VSD	VSD Micro Electronic Fault or Drive EEPROM Fault
E90	E90	E90	VSD	VSD Compressor Model Configuration Error
E91	E91	E91	VSD	VSD Inverter Temp Imbalance
E92	E92	E92	VSD	VSD PFC Temp Imbalance
E93	E93	E93	VSD	VSD Motor Temp Low
E94	E94	E94	VSD	VSD Board Temp Low
E95	E95	E95	VSD	VSD Power Module Temp Low or Sensor (Open or short circuit)
E96	E96	E96	VSD	VSD PFC Module Temp. Sensing Circuit Malfunction
E97	E97	E97	VSD	VSD IC Reset Malfunction
E98	E98	E98	VSD	VSD Current Sensing Circuit Malfunction
E99	E99	E99	VSD	VSD Other Malfunction
E100	E100	E100	VSD	VSD Charging Circuit Malfunction
E101	E101	E101	VSD	VSD PFC Software Over Current
E102	E102	E102	VSD	DC Fan Motor 1 Malfunction
E103	E103	E103	VSD	DC Fan Motor 2 Malfunction

PFC: Power Factor Correction
DSP: Digital Signal Processor

IGBT: Insulated-Gate Bipolar Transistor
ADC: Analog to Digital Converter

07. Fault Code Troubleshooting

Fault Code	Description	Possible Causes	Remedies
E01 Indoor Fan RPM Feedback Error	E01 will be displayed on all connected wall controls every time the unit is switched on	Incorrect fan pulse/rev set	Set correct fan pole in ODU 7 seven segment. Navigate to set > idus > Fnse to change value.
E03 Indoor Room Temp. Sensor Error	E03 will be displayed on all connected wall controls every time the unit is switched on.	Faulty wall sensor or cable	Replace faulty sensor or cable
E04 Indoor Coil In Temp. Sensor Error	No preheat on start up (heating mode only), indoor fan will come on straight away.	Indoor coil sensor is open or short circuit.	Replace indoor sensor
	After de-ice, indoor fan will start after 30 seconds.		
	E04 will be displayed every time it is switched on.		
E06 High Discharge Temperature	The compressor discharge temperature (Cdt) has exceeded 138 °C and the system has been stopped. When the temperature has normalised to 80 °C or 8 minutes delay has been finished, the controller will attempt to return to normal conditions.	Under charged with refrigerant.	Check for refrigerant leaks and repair.
E07 Outdoor Coil Temp. Sensor Error	Outdoor fans will operate on high speed only (while unit is running).	Outdoor coil sensor is open or short circuit.	Replace outdoor coil sensor
	E07 will be displayed every time the system is switched on.	Faulty sensor.	Check the sensor resistance.
E08 Discharge Temp. Sensor Error	The reading of the discharge temperature sensor (Cdt) is not within the specified sensor range of -60 °C to +200°C.	Discharge temperature sensor is open or short circuit.	Replace discharge temperature sensor.
		Faulty sensor.	Check the sensor resistance.
E09 LP Switch Tripped	Low Pressure Control will cut out the system (i.e. stop the compressor and fans) if a pressure less than 165kPa is detected. Compressor stops for 5 minutes for the 1st and 2nd trip. If the low pressure switch trips out three times in a row, then the unit will remain off for 15 minutes before attempting to re-start. For the system to restart after a Low Pressure cut out, the pressure switch needs to detect a pressure greater than 330kPa.	Insufficient airflow over indoor coil during cooling operation	Check indoor fan operation to ensure sufficient airflow is flowing across the indoor coil.
		Undercharged with refrigerant	Check for refrigerant leaks and repair.
		Insufficient airflow over outdoor coil during heating operation	Check for dirty outdoor coil and inspect outdoor fan operation.
		Blockage in refrigeration system	Remove blockage from refrigeration system.
		Dirty filter	Clean Filter.
E10 LP Sensor Error (open/short circuit)	The reading of the suction pressure transducer is not within the specified sensor range.	Faulty wiring or defective transducer.	Replace the transducer. Correct the wiring.

Fault Code	Description	Possible Causes	Remedies
E11 HP Switch Tripped	High Pressure Control will cut out the system (i.e. stop the compressor and fans) if a pressure greater than 4502kPa is detected. Compressor stops for 5 minutes for the 1st and 2nd trip. If the high pressure switch trips out three times in a row, then the unit will remain off for 15 minutes before attempting to re-start. For the system to restart after a High Pressure cut out, the pressure switch needs to detect a pressure less than 3509kPa.	Insufficient airflow over indoor coil during heating operation	Check indoor fan operation to ensure sufficient airflow is flowing across the indoor coil
		Overcharged with refrigerant	Check for refrigerant leaks and repair.
		Insufficient airflow over outdoor coil during cooling operation	Check for dirty outdoor coil and inspect outdoor fan operation
		Blockage in refrigeration system	Remove blockage from refrigeration system
		Dirty filter	Clean Filter
E12 HP Sensor Error (open/short)	The reading of the condenser pressure transmitter is not within the specified sensor range.	Faulty wiring or defective transducer.	Replace the transducer. Correct the wiring
E13 VSD Fault Signal	E13 will be displayed on the ODB when the VSD sends a fault signal to the ODB.	VSD overheating.	Ensure proper airflow/cooling over the drives heat-sink.
		Incorrect supply voltage	Ensure line voltage is > 187 VAC. Check system for loose connections or hot joints.
		Incorrect or loose VSD Wiring	Ensure wiring is correct and screws and terminals are tight.
		VSD HP loop open circuit (Advance R-410A only)	Ensure that the drives HP bypass is connected.
E15 Communication Error Between ODU to VSD	No communication data received for 20 seconds.	Check modbus communication cable connection.	Make sure the communication cable is connected correctly.
	E15 (With no light on the drive)	Power cycle the drive.	
E18 Suction Temp. Sensor Error (Open/short circuit)	The reading of the suction temperature sensor (Sst) is not within the specified sensor range.	Suction temperature sensor is open or short circuit.	Replace suction temperature sensor.
		Faulty sensor.	Check the sensor resistance.
E22 Ambient Temp. Sensor Error (Open/short circuit)	The reading of the ambient temperature sensor is not within the specified sensor range.	Ambient temperature sensor is open or short circuit.	Replace ambient temperature sensor.
		Faulty sensor.	Check the sensor resistance.
E26 VSD Supply Over Current	The drive has encountered an over current event and has stopped operation.	An over current can be triggered by low voltage.	Rectify low voltage power supply.
		Check if the compressor is operating within specified pressure limits.	Find the root cause for not operating the compressor in the specified limits.
		Faulty drive.	Replace drive if the problem still persists.

Fault Code	Description	Possible Causes	Remedies
E27 VSD Supply Over Voltage	The drive has encountered an over voltage event.	Measure the input voltage to the drive. It should not be more than 575VAC.	Input voltage should be rated value range.
		Check if the compressor is operating within specified pressure limits.	Find the root cause for not operating the compressor in the specified limits.
E28 VSD Temperature High	The drive has encountered an over temperature condition and has stopped operation.	Verify proper airflow over the heat-sink of the drive.	Remove any obstructions.
		Check if the compressor is operating within specified pressure limits.	Find the root cause for not operating the compressor in the specified limits.
		Check the mounting screws on the drive, If the problem, still persists replace the drive.	Make sure they are tight.
E29 VSD Low Supply Voltage	The drive has encountered an under-voltage event.	Measure the input voltage to the drive. It should not drop below 295VAC.	Input voltage should be rated value range.
		Check if the compressor is operating within specified pressure limits.	Find the root cause for not operating the compressor in the specified limits.
E30 VSD Trip Lock	Certain faults have a trip limit	VCD Drive trips lock because of multiple errors. Refer to Outdoor Board history to diagnose more for related error code	Reset the power supply
E41 VSD DC Link Voltage Low	The drive has encountered an DC bus voltage low.	Check the AC power supply.	Make correct supply voltage.
		Check if the compressor is operating within specified pressure limits.	Find the root cause for not operating the compressor in the specified limits or restart the drive again.

Fault Code	Description	Possible Causes	Remedies
E42 and E45 Envelope Protection Error	<p>As the compressor starts, it will wait until the compressor envelope control start delay has expired. Once the delay has expired, only then will the compressor start to track the floating point which is defined by HP/LP saturation temperature with respect to the selected compressor envelope (the compressor envelope has been divided in to the four parts – Extreme low evaporating pressure, High compression ratio, High condensing pressure, Low compression ratio.</p> <p>In the case of when the compressor operates outside the envelope boundaries, there is an allowable time of which the compressor may continue to operate – these time restrictions are tabulated below.</p> <p>The compressor will turn off if the allowable time-out expires. After 180 seconds, the UNO controller will auto reset according to the respective error code and start again to user define mode.</p> <p>System can trip on any of the four envelope protection error code:</p>		
	E42: Unit will trip on this error code if compressor is running outside the envelope boundary on extremely low evaporating pressure side for 20sec.	Same as E09	Same as E09
	E43: Unit will trip on this error code if compressor is running outside the envelope boundary on high compression ratio side for 3sec.	Insufficient airflow over indoor coil during heating operation Under or overcharged with refrigerant	Check indoor fan operation to ensure sufficient airflow is flowing across the indoor coil Amend gas charge until charge is correct
	E44: Unit will trip on this error code if compressor is running outside the envelope boundary on high condensing pressure side for 3sec.	Same as E11	Same as E11
	E45: Unit will trip on this error code if compressor is running outside the envelope boundary on low compression ratio side for 90sec.	System may be running outside the operating limits. Outdoor fan relay might be stuck on the high speed.	Make sure system should not be operated outside the operating range. Replace the outdoor board.
E47 Compressor Torque Limit Error	Motor torque has exceeded its limits	Compressor running outside the operating limits. Overcharged with refrigerant.	Airflow across the indoor or outdoor coil is not proper. Amend gas charge until charge is correct

Fault Code	Description	Possible Causes	Remedies
E50 Outdoor Board Configuration Error	UNO Board has not been configured.	Outdoor board is not configured	Configured the outdoor board correctly
E51 Communication Error Between ODU to VSD	Communication between outdoor and indoor board. Outdoor board has not been configured correctly.	Faulty outdoor and indoor board or cable. Outdoor board is not configured.	Replace the faulty board. Configured the outdoor board correctly.
E52 Fault IDU - Wall Control Communication Error	Communication error between wall control and indoor board.	Faulty wall controller or cable	Replace faulty wall controller or cable
		Conflicting address with controller assignment or two controls have the same assignment number	Re-assign controllers correctly
E55 Communication Error Between BMS to ODU	ICUNO-MOD to Outdoor Board Communication Fault.	Faulty ICUNO-MOD	Replace faulty ICUNO-MOD
		Incorrect Control Mode set on Outdoor Board	Ensure correct control mode is set
E56 No Master Wall Control Detected	No Master Wall Control (C-1) is detected. System will lock out until a C-1 assignment is detected.	Master Controller (C-1) Faulty	If an additional Wall Control (C-2 or C-3) is available, remove the faulty Master controller and re-assign one of the available controllers to C-1
		Connected controller/s have not been assigned as C-1	Re-assign a connected controller to C-1
E60 VSD Compressor Phase Over Current	Compressor Phase Over Current	Check the U/V/W connections on drive side.	Make them correct.
		Check the compressor motor windings	
		Check if the compressor is operating within specified pressure limits.	Find the root cause for not operating the compressor in the specified limits.
		Sensor on Drive not reading properly	Replace Drive
E62 VSD DC Bus Over Voltage	DC Bus Over Voltage	Check the DC bus voltage if it is > 800VDC.	
		Check if the compressor is operating within specified pressure limits.	Find the root cause for not operating the compressor in the specified limits.
E63 VSD DC Bus Under Voltage	DC Bus Under Voltage or Incoming phase power loss Phase loss (filter to VSD).	Check the DC bus voltage if it is < 300VDC.	
		Check if the compressor is operating within specified pressure limits.	Find the root cause for not operating the compressor in the specified limits.

Fault Code	Description	Possible Causes	Remedies
E70 VSD Lost Rotor Position	Lost Rotor Position or Phase lost to compressor.	Check the U/V/W connections on drive side.	Make them correct.
		Check the compressor motor windings	
		Check if the compressor is operating within specified pressure limits.	Find the root cause for not operating the compressor in the specified limits.
		System over charge	Make it correct.
E71 VSD Motor Temp Sensor Error	AC Input Current Fold Back Timeout	Check if the line voltage if it is < 187VAC	
		Check if the compressor is operating within specified pressure limits.	Find the root cause for not operating the compressor in the specified limits.
		Faulty drive	Replace drive.
E76 VSD Power Module Temp. Fold Back Timeout	Power Module Temp. Fold Back Timeout	Verify proper airflow over the heat-sink of the drive.	Remove any obstructions.
		Check if the compressor is operating within specified pressure limits.	Find the root cause for not operating the compressor in the specified limits.
		Check the mounting screws on the drive, If the problem, still persists replace the drive.	Make sure they are tight.
E78 VSD Auto Config Communication Timeout	Auto Config Communication Fault Timeout. Baud rate or Parity of the system controller not matching with drive.	Drive is not configured.	Replace the drive
E82 VSD Power Module Temp High	Power Module Temp. High	Verify proper airflow over the heat-sink of the drive.	Remove any obstructions.
		Check if the compressor is operating within specified pressure limits.	Find the root cause for not operating the compressor in the specified limits.
		Check the mounting screws on the drive, If the problem, still persists replace the drive.	Make sure they are tight.
E85 Communication Error in VSD Between Comms to DSP	COM MCU and DSP Communication Lost	Check mod-bus communication cable connections.	Refer wiring diagram & correct it.
		Faulty drive	Replace the drive.
E86 Compressor Phase Current Imbalance	Compressor Phase Current Imbalance	Check the U/V/W connections on drive side.	Make them correct.
		Check the compressor motor windings	
		Check if the compressor is operating within specified pressure limits.	Find the root cause for not operating the compressor in the specified limits.
		System over charge	Make it correct.

Fault Code	Description	Possible Causes	Remedies
E88 VSD Micro Electronic or EEPROM Error	Microelectronic Fault / EEPROM fault. DSP self-check error.	Drive configure issue.	Restart the drive and fault should go away.
		Faulty drive.	Replace the drive.
E90 VSD Compressor Model Configuration Error	Compressor Model Configuration Error	Drive configuration issue.	Replace the drive.
E95 VSD Power Module Temp Low or Sensor (Open or short circuit)	Power Module Temp. Low or Sensor Open fault	Verify proper airflow over the heat-sink of the drive.	Remove any obstructions.
		Check if the compressor is operating within specified pressure limits.	Find the root cause for not operating the compressor in the specified limits.
		Check the mounting screws on the drive, If the problem, still persists replace the drive.	Make sure they are tight.

THIS PAGE WAS INTENTIONALLY LEFT BLANK



©Copyright 2019 Actron Engineering Pty Limited ABN 34 002767240. ®Registered Trade Marks of Actron Engineering Pty Limited.
ActronAir is constantly seeking ways to improve the design of its products, therefore specifications are subject to change without notice.