

MULTIELITE

INSTALLATION MANUAL

Multi Split System Air Conditioner



Model Numbers:

MRC-052AS-2

MRC-071AS-3

MRC-100AS-4

MRC-110AS -5

MRC-135AS -5

IMPORTANT NOTE:

Please read this manual carefully before installing or operating your new air conditioning unit and keep it available for future reference. This owner's manual only refers to use of the outdoor unit. When using the indoor unit, refer to the owner's manual for the indoor unit.



Table of Contents

Installation Manual

1	Safety Precautions	04
2	Components	05
3	Installation Overview	06
4	Refrigerant Piping Connection	11
5	Wiring	12
6	Leak Test and Air Evacuation	22
7	Electrical & Gas Leak Checks	25
8	Test Run	26
9	Function of Automatic Wiring/Piping Connection	27
10	Maintenance	28

READ SAFETY PRECAUTIONS BEFORE INSTALLATION

Incorrect installation due to ignoring instructions can cause serious damage or injury. The seriousness of potential damage or injuries is classified as either a WARNING or CAUTION.



WARNING

Failure to observe a warning may result in death or serious injury. The appliance must be installed in accordance with national regulations



CAUTION

Failure to observe a caution may result in injury or equipment damage.

Note about Fluorinated Gases

1. This air conditioning unit contains fluorinated gas. For specific information on the type of gas and the amount, please refer to the relevant label on the unit itself.
2. Installation, service, maintenance and repair of this unit must be performed by a qualified HVAC technician.
3. Product uninstallation and recycling must be performed by a qualified HVAC technician.
4. When the unit is checked for leaks, proper record-keeping of all checks is strongly recommended.

FOR COMPLIANCE WITH
QUEENSLAND ELECTRICAL SAFETY
REGULATIONS 2013

This refers to electrical works only



**MUST BE INSTALLED BY A
LICENSED ELECTRICIAN**

This manual is a controlled document which contains confidential and proprietary information. Distribution, modification, copying and/or reproduction are prohibited without written consent from ActronAir

Product design and specifications are subject to change without prior notice for product improvement.

WARNING

1. Carefully read all the Safety Precautions before installation.
2. In certain functional environments, such as kitchens, server rooms, etc., the use of specially designed air-conditioning units is highly recommended.
3. Only qualified HVAC technicians* should install, repair and service this air conditioning unit. Improper service or alteration by unqualified technician could result in significant and major damage to the product or property which may render your warranty null and void. Such unqualified service could also lead to severe physical injury or death. Follow all safety instructions in this literature and all warning labels that are attached to the equipment.
4. During installation, ensure there are no refrigerant leaks. Refrigerant is toxic and poses a serious health and safety risk.

*Qualifications required will be appropriate Electrical, Refrigeration and Refrigerant Handling License & Training, dependent on local State/Territory regulations.

SAFETY INSTRUCTIONS

1. Prevailing WH&S regulations must be observed and will take precedence to the safety instructions contained on this manual. Safe work practices and environment must be the paramount importance in the performance of all the service procedures.
2. Ensure that unit installation complies with relevant council regulations and building code standards.
3. All electrical wiring must be in accordance with current electrical authority regulations and all wiring connections to be as per electrical diagram provided.
4. Always wear appropriate PPE, remove any dangling jewellery and protect long hair by wearing a cap.
5. Make sure that safety guards and panel covers are always firmly secured and not damaged.
6. This appliance is not intended for use by young children or infirm persons unless they have been adequately supervised by a responsible person to ensure that they can use the appliance safely. Young children should be supervised to ensure that they do not play with the appliance.
7. Installer must incorporate a means of electrical disconnection (isolator) in the sub mains fixed wiring in accordance with the Australian wiring rule (AS3000).
8. Secure the power cords and control cables that goes in/out the unit. Use the cable ties provided in the control box.





CAUTION

- ⊘ **Do not** install the unit in a location that may be exposed to combustible gas leaks. If combustible gas accumulates around the unit, it may cause fire.
 - ⊘ **Do not** install your air conditioner in a wet room such as a bathroom or laundry room. Too much exposure to water can cause electrical components to short circuit.
1. The product must be properly grounded at the time of installation, or electrical shock may occur.
 2. Install drainage piping according to the instructions in this manual. Improper drainage may cause water damage to your home and property.

2. Components

Multi Split System

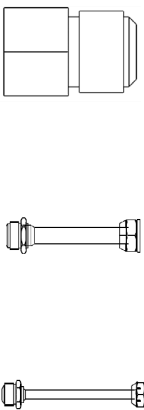
The air conditioning system comes with the following components. Use all of the installation parts and accessories to install the air conditioner. Improper installation may result in water leakage, electrical shock and fire, or cause the equipment to fail.

Name	Shape	Quantity		
Drain joint (some models)		1		
Seal ring (some models)		1		
Pipe Adaptor (NOTE: Pipe size may differ from appliance to appliance. To meet the different pipe size requirements, sometimes the pipe connections need the adaptor to be installed to the outdoor unit.)		Model	Adaptor	Quantity
		MRC-052AS-2	Ø9.52 - Ø12.7	2
		MRC-071AS-3	Ø9.52 - Ø12.7	2
			Ø6.35 - Ø9.52	1
		MRC-100AS-4	Ø12.7 - Ø9.52	1
			Ø12.7 - Ø15.9	1
			Ø9.52 - Ø15.9	1
		MRC-110AS-5	Ø9.52 - Ø12.7	1
			Ø12.7 - Ø15.9	3
			Ø9.52 - Ø12.7	1
		MRC-135AS-5	Ø6.35 - Ø9.52	2
			Ø12.7 - Ø9.52	2
			Ø12.7 - Ø15.9	2
Owner's manual		1		
Installation manual		1		

Optional Accessories

There are two types of controllers: wall controller(wired) and remote controller (wireless).

Select a controller according to customers request and install in an appropriate place.

Refer to catalogues and technical literature for selecting a suitable controller, for the indoor unit used.

Installation Overview

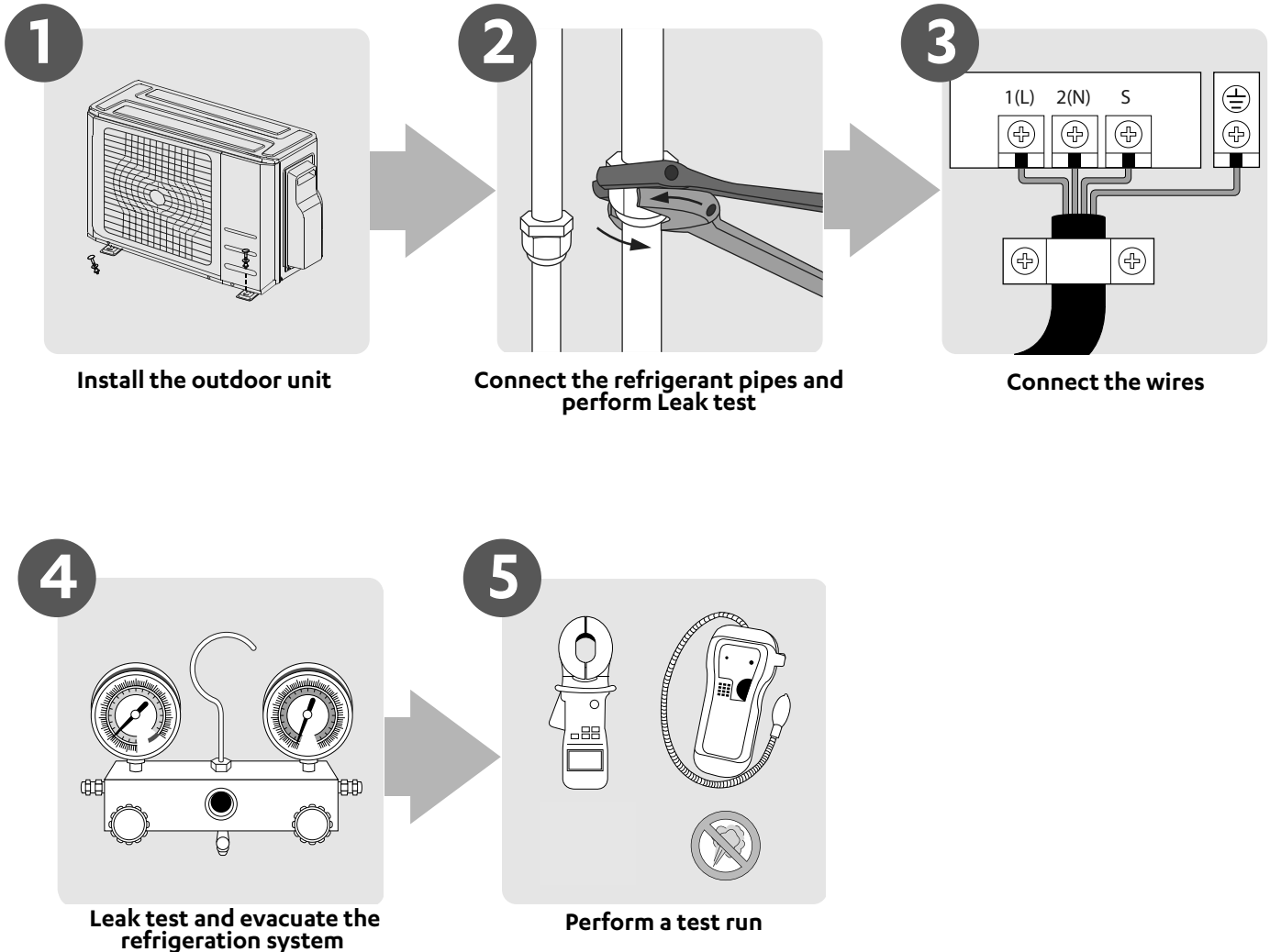

! CAUTION

- A minimum pipe run of 6 metres is recommended to minimise vibration & excessive noise.

3. Installation Overview

Multi Split System

Specification

Table 3.1

Indoor units that can be used in combination	number of connected units	1-5
Compressor stop start frequency	stop time	3 min or more
Power source voltage	voltage supply	230VAC (-6%/+10%)
	voltage drop during start	±5% of rated

Table 3.2

		1 outdoor			
		2 indoor	3 indoor	4 indoor	5 indoor
Minimum Field Pipe Length (m) - 1 indoor unit		6	9	12	15
Maximum length for all rooms (m)		30	60	60	80
Maximum length for one indoor unit (m)		25	30	35	35
Maximum height difference between indoor and outdoor unit (m)	OU higher than IU	15	15	15	15
	OU lower than IU	15	15	15	15
Maximum height difference between indoor units (m)		10	10	10	10

When installing multiple indoor units to a single outdoor unit, ensure that the length of the refrigerant pipe and the height difference between the indoor and outdoor and indoor to indoor units meet the following requirements:

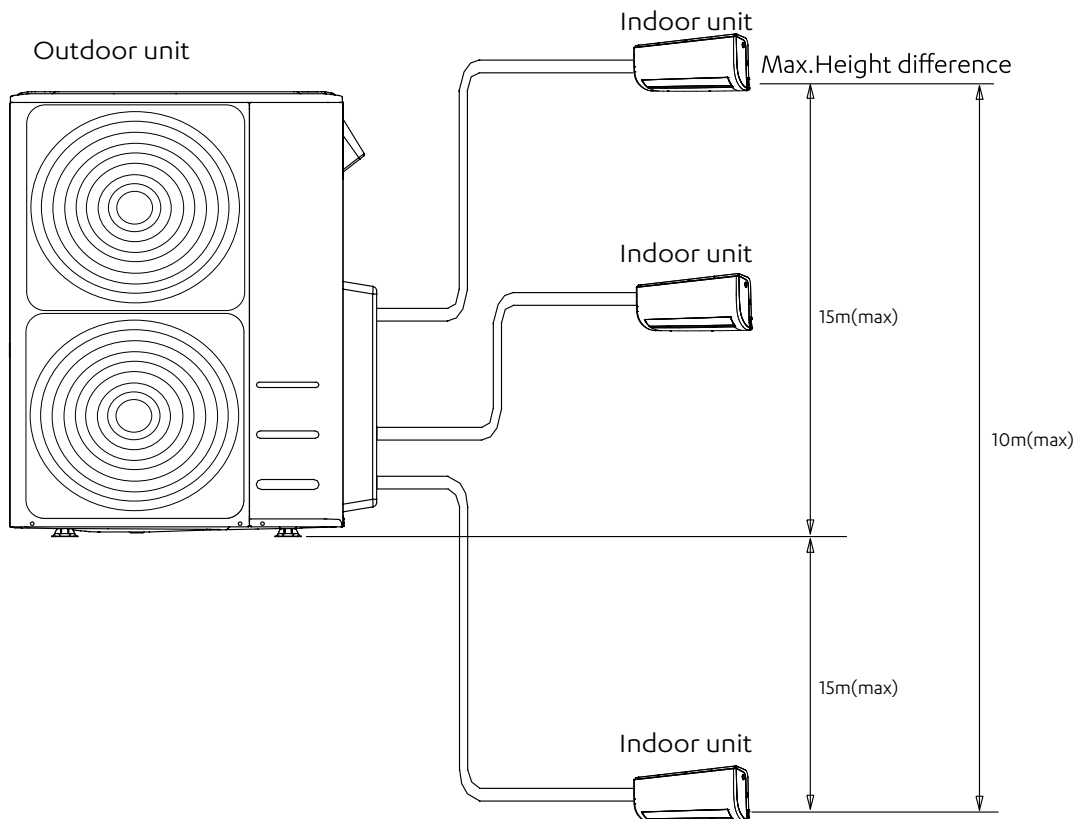

Outdoor Unit Installation Instructions

Step 1: Select installation location

The outdoor unit should be installed in the location that meets the following requirements:

- ☑ Place the outdoor unit as close to the indoor unit as possible.
- ☑ Ensure that there is enough room for installation and maintenance.
- ☑ The air inlet and outlet must not be obstructed or exposed to strong wind
- ☑ Ensure the location of the unit will not be subject to snowdrifts, accumulation of leaves or other seasonal debris. If possible, provide an awning for the unit. Ensure the awning does not obstruct airflow.
- ☑ The installation area must be dry and well ventilated.
- ☑ There must be enough room to install the connecting pipes and cables and to access them for maintenance.

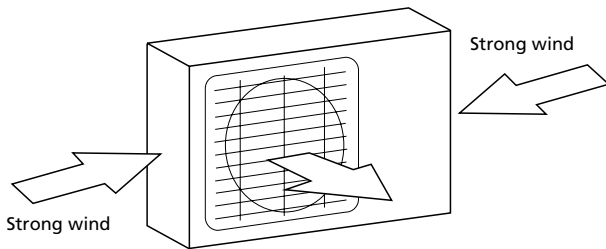

Fig. 3.1

- ☑ The area must be free of combustible gases and chemicals
- ☑ The pipe length between the outdoor and indoor unit may not exceed the maximum allowable pipe length.
- ☑ If possible, **DO NOT** install the unit where it is exposed to direct sunlight.
- ☑ If possible, make sure the unit is located far away from your neighbours' property so that the noise from the unit will not disturb them.
- ☑ If the location is exposed to strong winds (for example: near a seaside), the unit must be placed against the wall to shelter it from the wind. If necessary, use an awning. Ensure minimum space requirements are met. (See Fig. 3.1 & 3.2)
- ☑ Install the indoor and outdoor units, cables and wires at least 1 metre from televisions or radios to prevent static or image distortion. Depending on the radio waves, a 1 metre distance may not be enough to eliminate all interference.

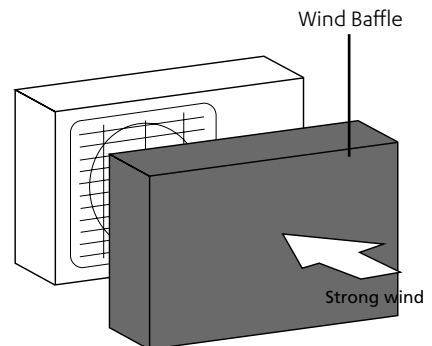

Fig. 3.2

Step 2: Install Outdoor Unit

Fix the outdoor unit with anchor bolts (M10)

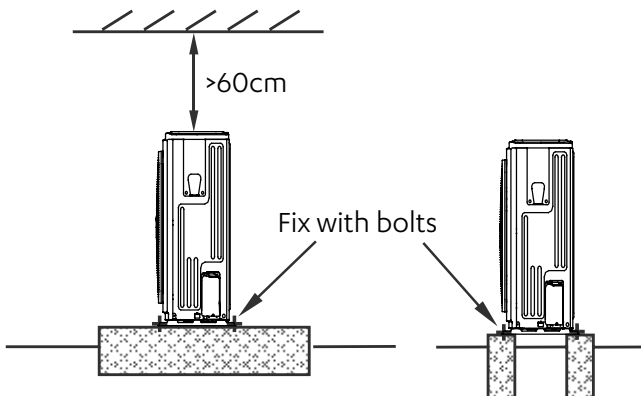

Fig. 3.3

! CAUTION

- Be sure to remove any obstacles that may block air circulation.
- Make sure you refer to Fig. 3.7 to ensure there is enough room for installation and maintenance.

Outdoor Unit Installation Instructions

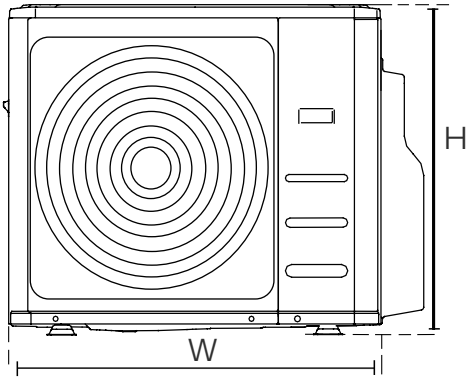

Fig. 3.4

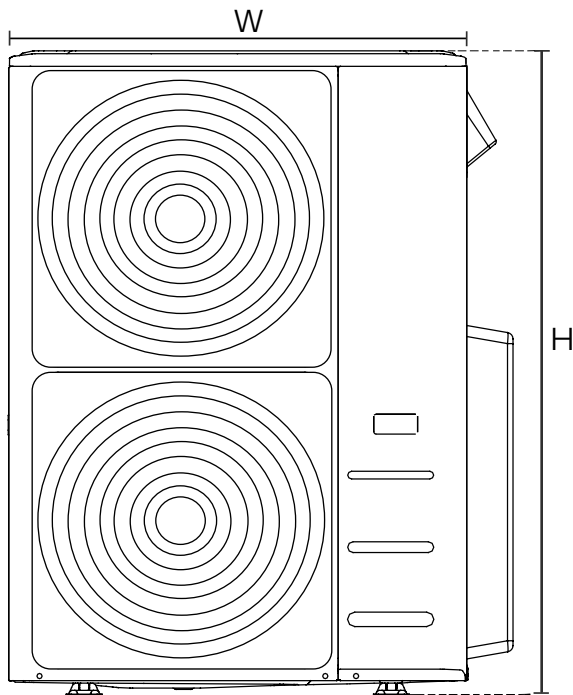

Fig. 3.5

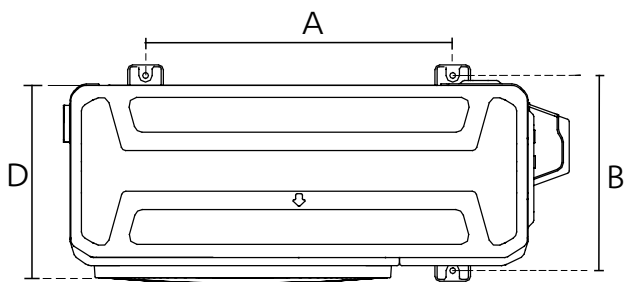

Fig. 3.6

Table 3.3
Dimensions of Multi Split Outdoor Unit (mm)

Model Number	Outdoor Unit Dimensions W x H x D (mm)	Mounting Dimensions	
		Distance A (mm)	Distance B (mm)
MRC052AS-2 MRC-071AS-3	845 x 702 x 363	540	350
MRC-100AS-4 MRC-110AS-5	946 x 810 x 410	673	403
MRC-135AS-5	952 x 1333 x 415	634	404

NOTE

The minimum distance between the outdoor unit and walls described in the installation guide does not apply to airtight rooms. Be sure to keep the unit unobstructed in at least two of the three directions (M, N, P). See Fig 3.7

Fig. 3.7

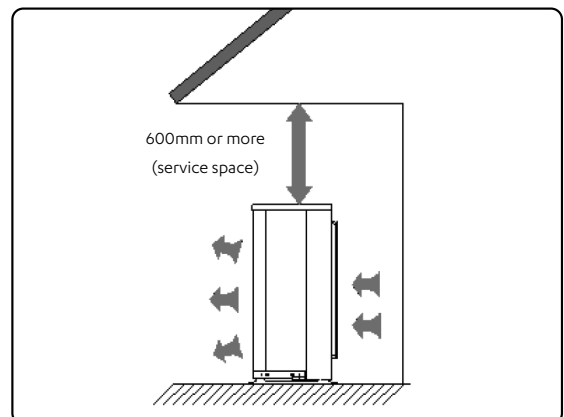
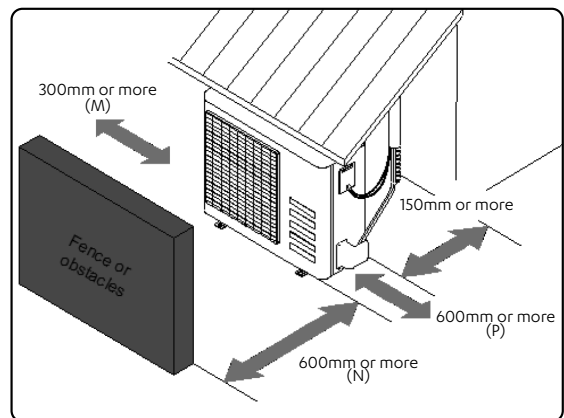

Overview

Drain Joint Installation

Before bolting the outdoor unit in place, you must install the drain joint at the bottom of the unit. (See Fig. 3.8).

1. Fit the rubber seal on the end of the drain joint that will connect to the outdoor unit.
2. Insert the drain joint into the hole in the base pan of the unit.
3. Rotate the drain joint 90° until it clicks in place facing the front of the unit.
4. Connect a drain hose extension (not included) to the drain joint to redirect water from the unit during heating mode.

NOTE

Make sure the water drains to a safe location where it will not cause water damage or a slipping hazard.

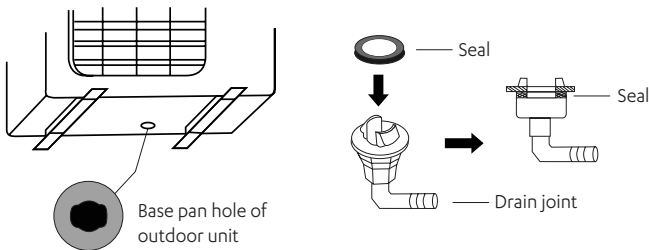

Fig. 3.8

Notes On Drilling Hole In Wall

You must drill a hole in the wall for the refrigerant piping, and the signal cable that will connect the indoor and outdoor units.

1. Determine the location of the wall hole based on the location of the outdoor unit.
2. Using a 65mm core drill, drill a hole in the wall.

NOTE

When drilling the wall hole, make sure to avoid wires, plumbing, and other sensitive components.

3. Place the protective wall cuff in the hole. This protects the edges of the hole and will help seal it when you finish the installation process.

Connecting 7kW Indoor Unit

The 7kW indoor unit can only be connected to the A port, if there are two 7kW indoor units, they can be connected to A and B port. (See Fig. 3.9). Please use pipe adaptors provided.

Table 3.4

Connecting pipe size of indoor unit

Indoor Unit Capacity	Liquid (mm)	Gas (mm)
2.6kW	6.35mm	9.52mm
3.5kW / 5kW	6.35mm	12.7mm
7kW	9.52mm	15.88mm

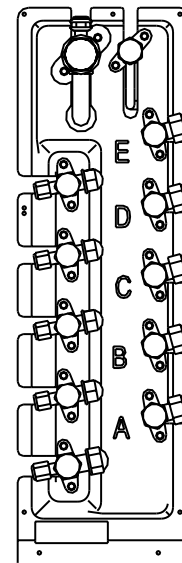

Fig. 3.9

Safety Precautions

! WARNING

- All field piping must be completed by a qualified HVAC technician and must comply with local and national regulations.
- When the air conditioner is installed in a small room, measures must be taken to prevent the refrigerant concentration in the room from exceeding the safety limit in the event of refrigerant leakage. If the refrigerant leaks and its concentration exceeds its proper limit, hazards due to lack of oxygen may result.
- When installing the refrigeration system, ensure that air, dust, moisture or foreign substances do not enter the refrigerant circuit. Contamination in the system may cause poor operating capacity, high pressure in the refrigeration cycle, explosion, injury or product failure and may void warranty.
- Ventilate the area immediately if there is refrigerant leakage during the installation. Leaked refrigerant gas can be toxic. Ensure there is no refrigerant leakage after completing the installation work.

Notes On Pipe Length and Elevation

Ensure that the length of the refrigerant pipe, the number of bends, and the drop height between the indoor and outdoor units meets the requirements shown in Table 3.2.

Refrigerant Piping Connection Instructions

1. Cut the connecting pipes according to required length.
2. Remove burrs in the pipe. Burrs can affect the air-tight seal of refrigerant piping connections.
3. Place flare nuts on both ends of pipe. Flare each end of connecting pipes.

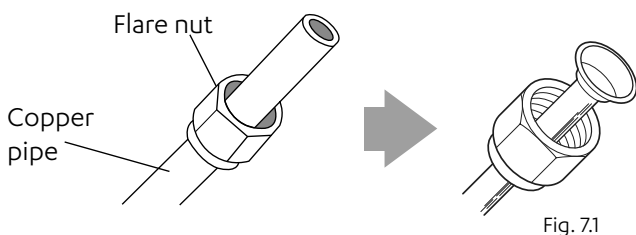

4. Connect the pipe to indoor and outdoor unit. Apply a thin coat of refrigeration oil to the flared end of the pipe. Tighten the flare nuts using a spanner and torque wrench.

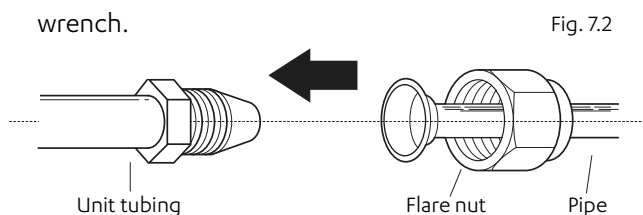

Table 4.1
Pipe Flare Dimension and Tightening Torque Guide

Pipe Size	Tightening Torque	Flare Dimension (A)		Flare Shape
		Min (mm)	Max (mm)	
ø 6.4	14.2 - 17.2 Nm	8.3	8.3	<p>Fig. 4.1</p>
ø 9.5	32.7 - 39.9 Nm	12.4	12.4	
ø 12.7	49.5 - 60.3 Nm	15.4	15.8	

! CAUTION

- Ensure to wrap insulation around the piping. Direct contact with the bare piping may result in burns or frostbite.
- Make sure the pipe is properly connected. Over tightening may damage the bell mouth and under tightening may lead to leakage.

Safety Precautions

! WARNING

- Be sure to isolate the power supply before working on the unit.
- All electrical wiring must be done according to local and national regulations.
- Electrical wiring must be done by qualified technician. Improper connections may cause electrical malfunction, injury and fire.
- Connect the power cable to the terminals and fasten it with a clamp. An insecure connection may cause fire.
- Make sure that all wiring is done correctly and the control board cover is properly installed. Failure to do so can cause overheating at the connection points, fire, and electrical shock.

! CAUTION

- Connect the outdoor wires before connecting the indoor wires.
- Make sure you earth the unit. Improper earthing may cause electrical shock.
- Insulate both the gas and liquid piping to prevent water leakage.
- **DO NOT** connect the unit with the power source until all wiring and piping is completed.
- Make sure that you do not cross your electrical wiring with your signal wiring, as this can cause distortion and interference.

Follow these instructions to prevent interference when the compressor starts:

- The unit must be connected to a separate sub circuit.
- No other equipment should be connected to the same same sub circuit.
- The unit's power information can be found on the rating sticker on the product.

Outdoor Wiring

! WARNING

Before performing any electrical or wiring work, isolate and lock out/tag out power to the A/C unit.

1. Prepare the cable for connection
 - a. Ensure the correct size cable has been selected, as per specifications.
 - b. Using wire strippers, strip the rubber jacket from both ends of signal cable.
 - c. Strip the insulation from the ends of the wires.
 - d. Using a wire crimper, crimp fork-lugs on the ends of the wires.

NOTE

While connecting the wires, please strictly follow the wiring diagram (found inside the electrical box cover).

2. Remove the electric cover of the outdoor unit. If there is no cover on the outdoor unit, disassemble the bolts from the maintenance board and remove the protection board. (See fig 4.1)

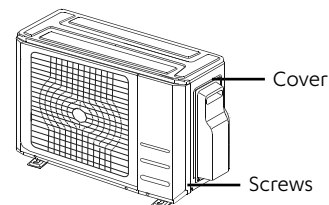

Fig. 5.1

3. Connect the fork lugs to the terminals. Match the wire colours / labels with the labels on the terminal block, and firmly screw the lug of each wire to its corresponding terminal.
4. Clamp down the cable with designated cable clamp.
5. Reinstall the cover of the electric control box.

5. Wiring

Multi Split System

Wiring Diagram MRC-052AS-2

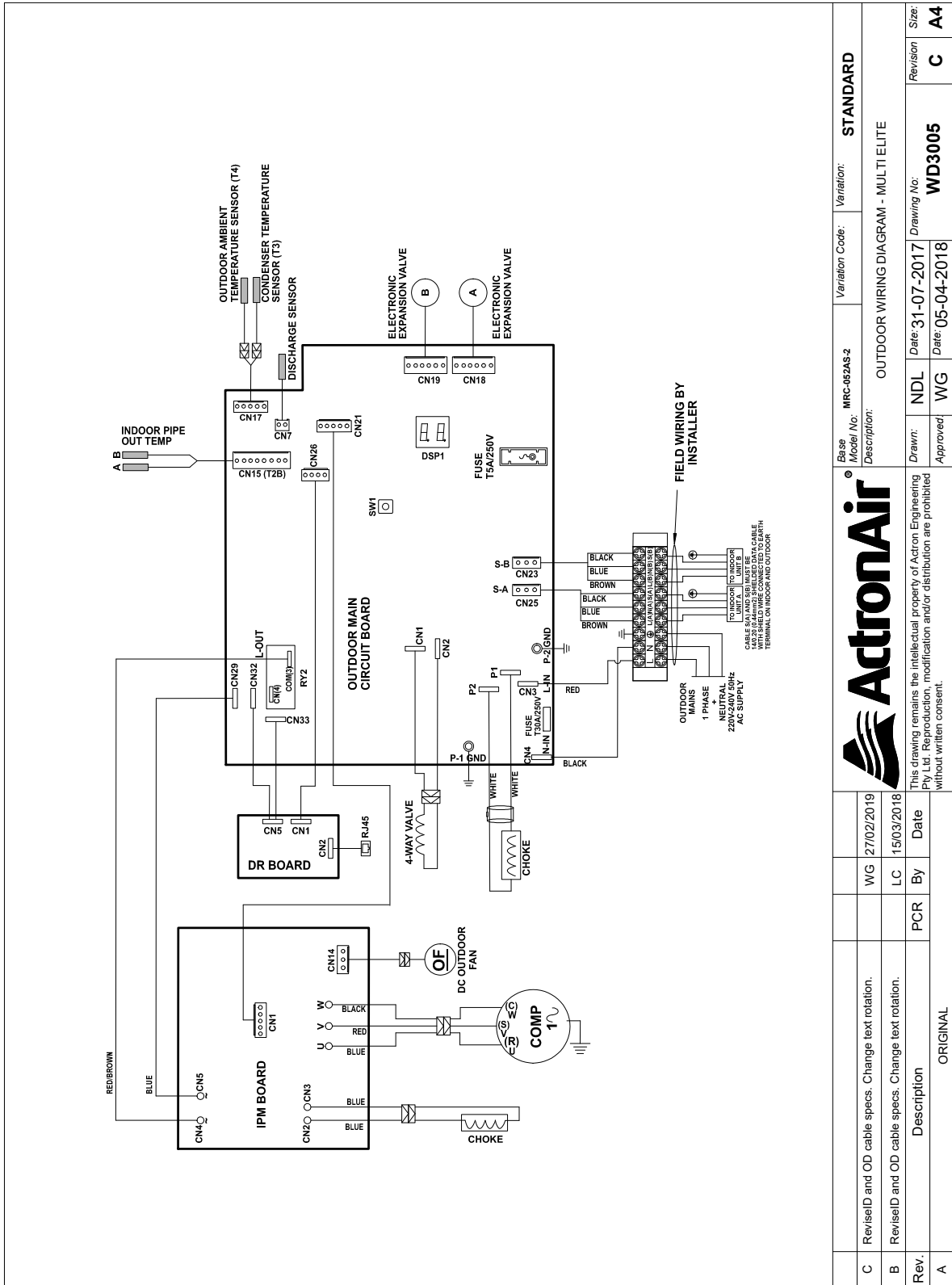

This drawing remains the intellectual property of Actron Engineering Pty Ltd. Reproduction, modification and/or distribution are prohibited without written consent.

5. Wiring

Multi Split System

Wiring Diagram MRC-071AS-3

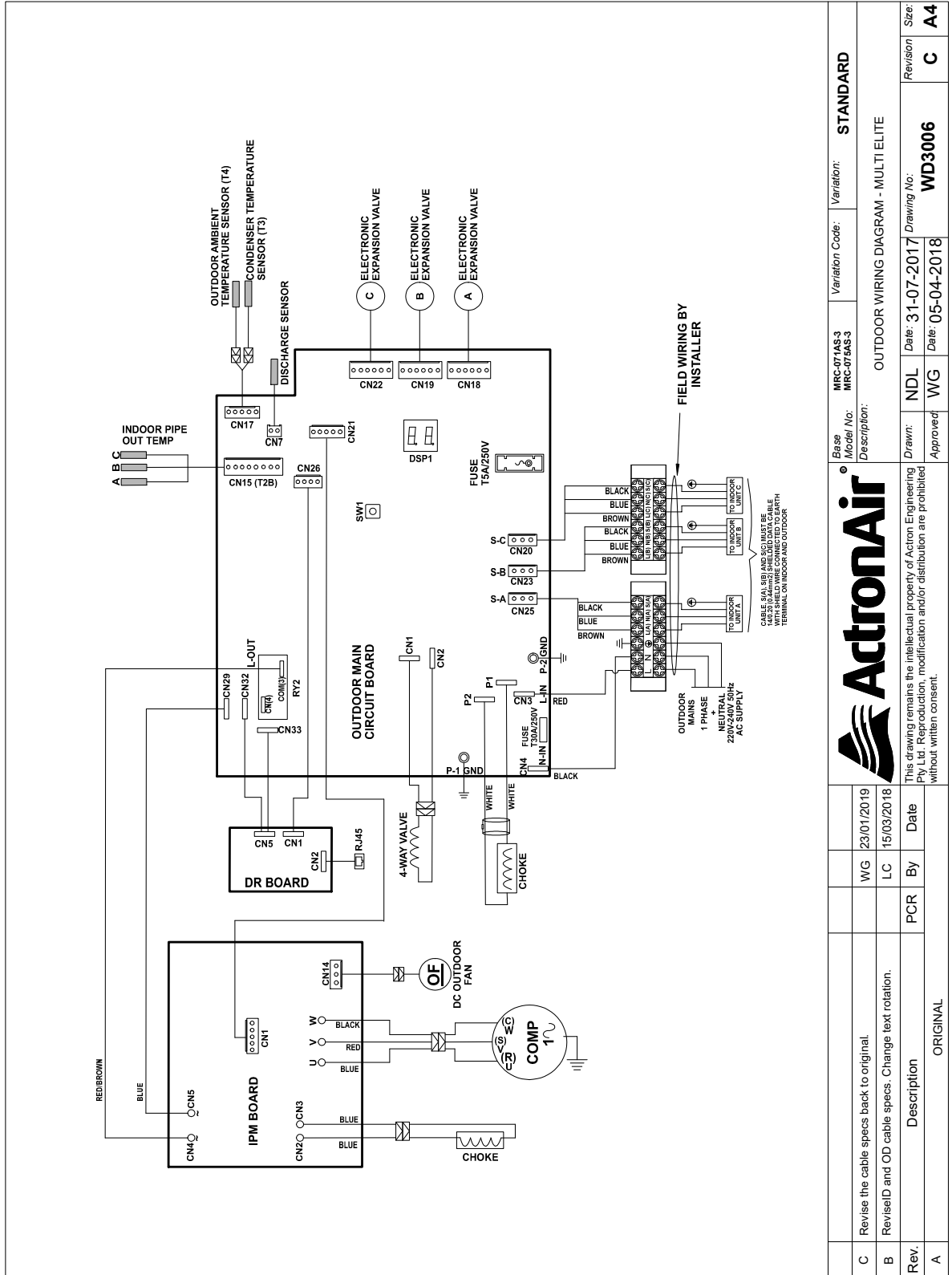

C	Revise the cable specs back to original.	WG	23/01/2019	
	B	ReviseID and OD cable specs - Change text rotation.	LC	15/03/2018
Rev.	Description	PCR	By	Date
A	ORIGINAL			

Base Model No:	MRC-071AS-3	Variation Code:	MRC-075AS-3	Variation:	STANDARD
Description: OUTDOOR WIRING DIAGRAM - MULTI ELITE					
Drawn:	NDL	Date:	31-07-2017	Drawing No:	WD3006
Approved:	WG	Date:	05-04-2018	Revision:	C
				Size:	A4



This drawing remains the intellectual property of Actron Engineering Pty Ltd. Reproduction, modification and/or distribution are prohibited without written consent.

5. Wiring

Multi Split System

Wiring Diagram MRC-100AS-4

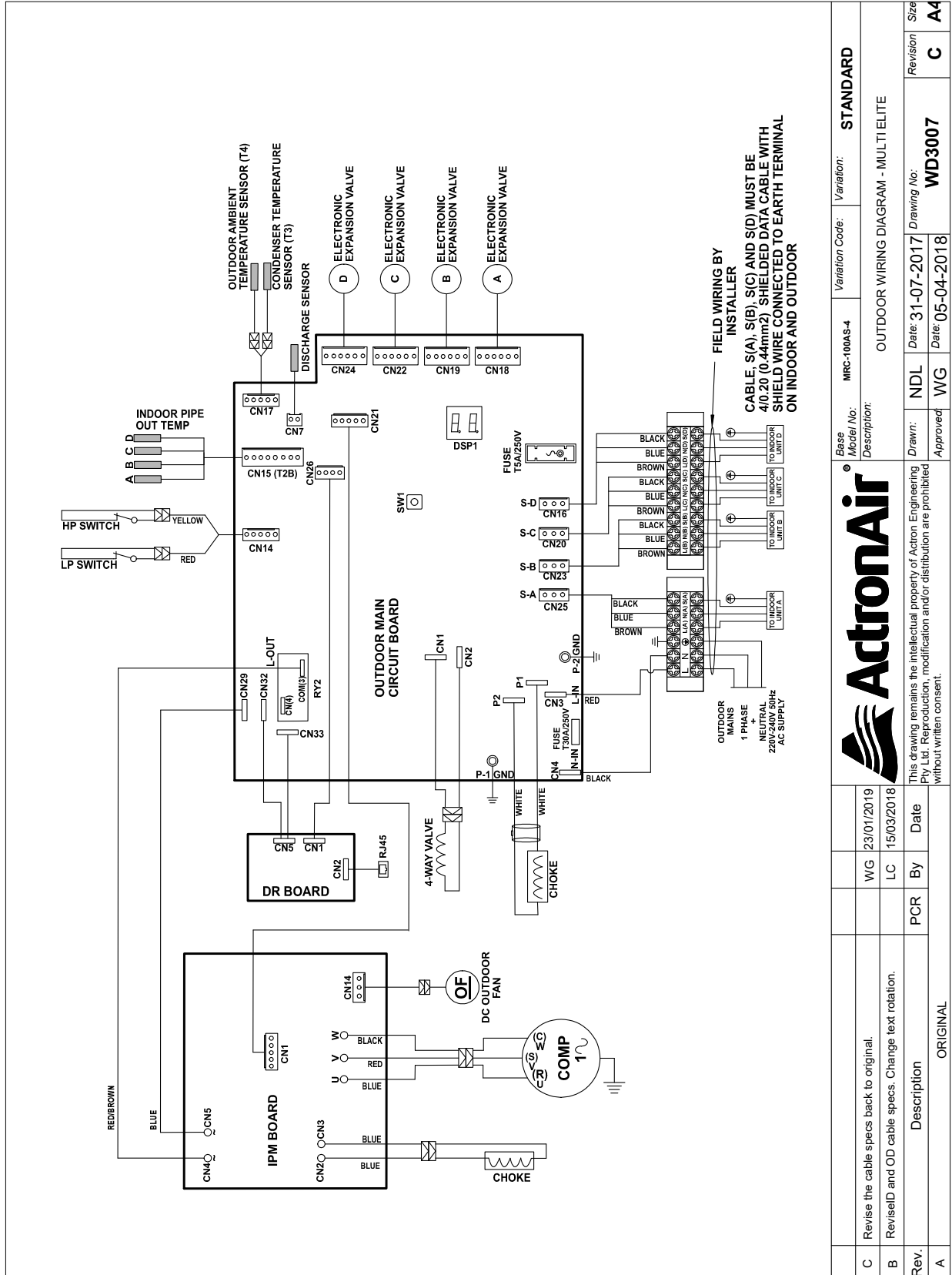

		Base Model No: MRC-100AS-4 Variation Code: STANDARD
Description: OUTDOOR WIRING DIAGRAM - MULTIELITE		
Rev. A	Description: ORIGINAL	Drawn: NDL Approved: WG Date: 31-07-2017 Date: 05-04-2018 Drawing No: WD3007
C	Revise the cable specs back to original.	Date: 23/01/2019 By: WG
B	Revise ID and OD cable specs. Change text rotation.	Date: 15/03/2018 By: LC
Size: A4	Revision: C	Size: A4

5. Wiring

Multi Split System

Wiring Diagram MRC-110AS-5

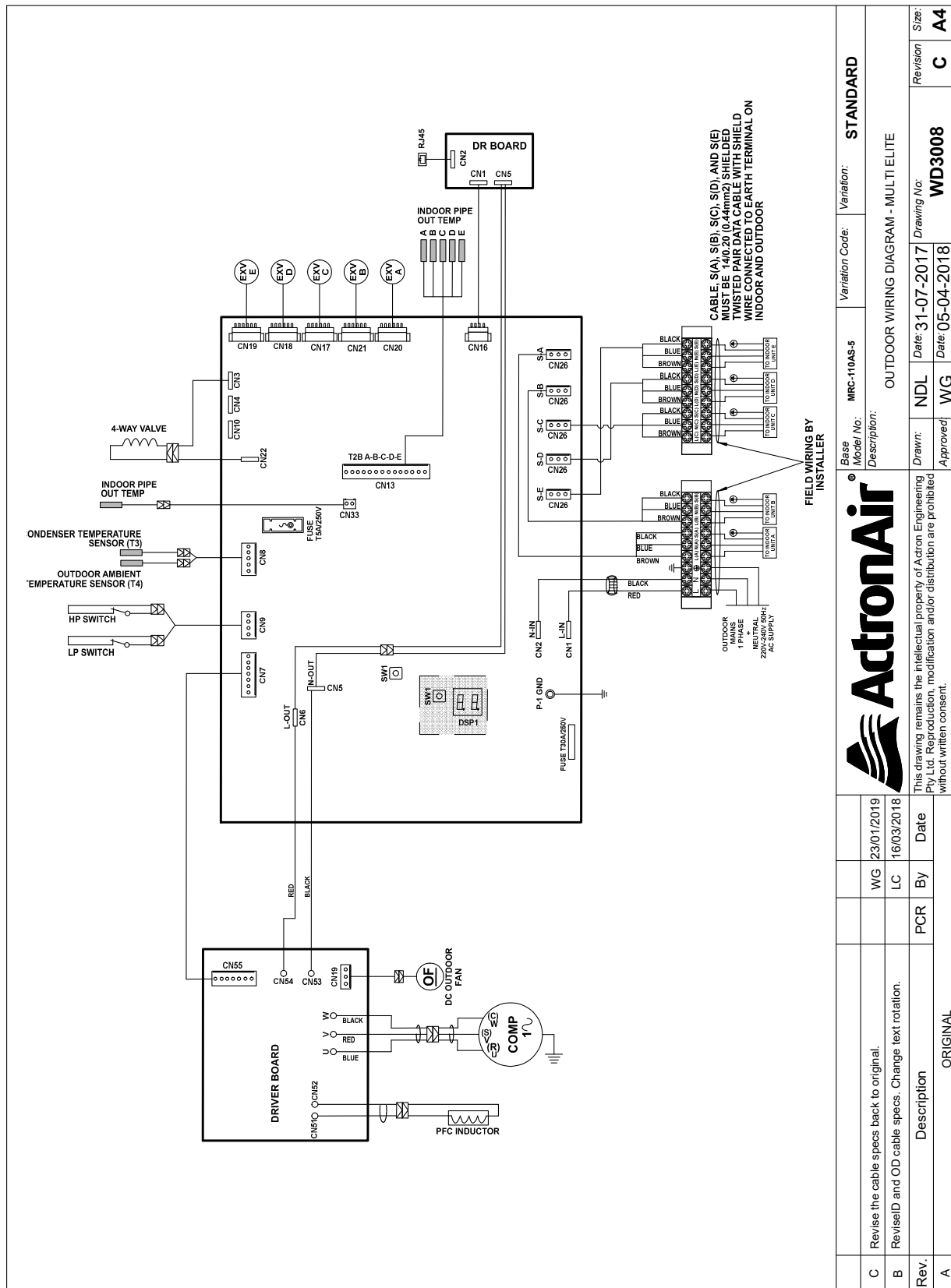

5. Wiring

Multi Split System

Wiring Diagram MRC-135AS-5

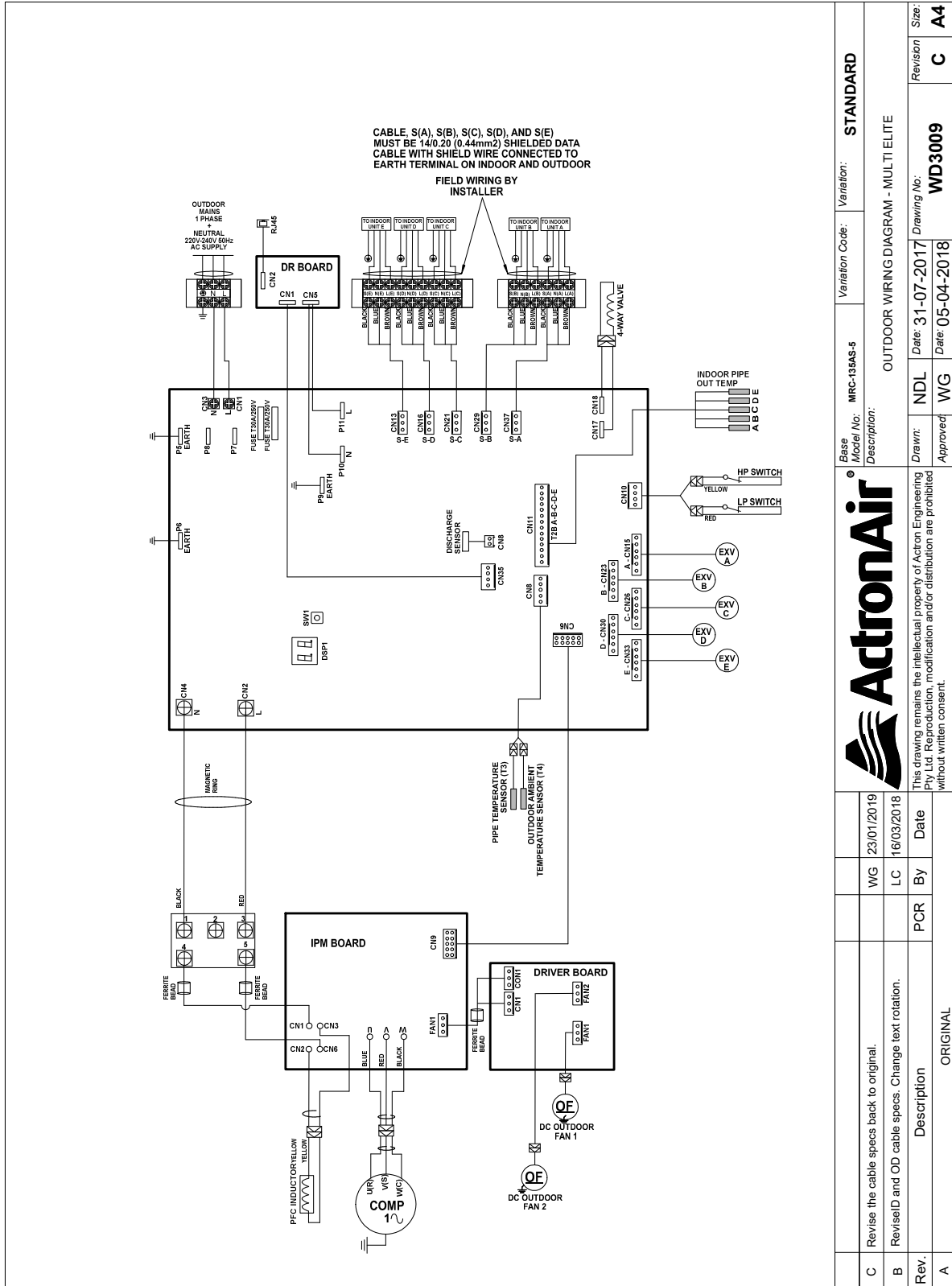

Base Model No: MRC-135AS-5		Variation Code: STANDARD	
Description: OUTDOOR WIRING DIAGRAM - MULTI TELITE		Drawing No: WD3009	
Drawn: NDL	Date: 31-07-2017	Revision: C	Size: A4
Approved: WG	Date: 05-04-2018		
Rev. C	WG	23/01/2019	Revise the cable specs back to original.
Rev. B	LC	16/03/2018	Revise ID and OD cable specs. Change text rotation.
Rev. A	PCR		ORIGINAL



This drawing remains the intellectual property of Actron Engineering Pty Ltd. Reproduction, modification and/or distribution are prohibited without written consent.

Field Wiring Connection

! CAUTION

Connect the field wirings to the terminals as specified on the terminal block of indoor and outdoor units.

Magnetic Ring (supplied, on selected outdoor models). Clip this around the connecting wires during installation.

MRC-052AS-2 Connecting Diagram

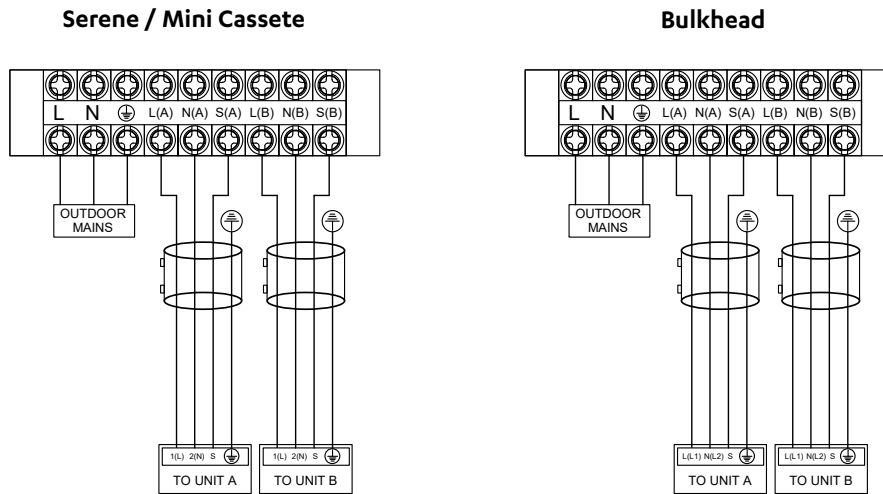

MRC-071AS-3 Connecting Diagram

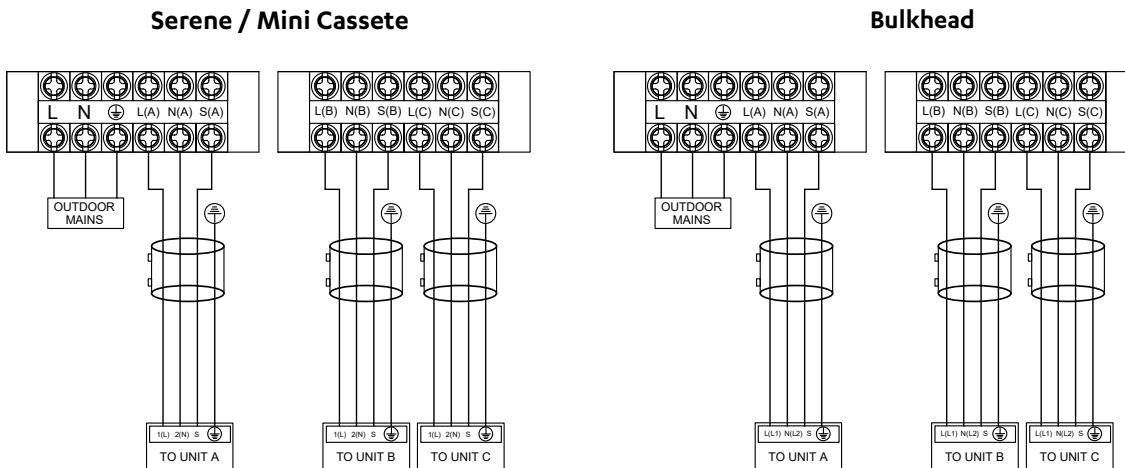

MRC-100AS-4 Connecting Diagram

Serene / Mini Cassete

Bulkhead

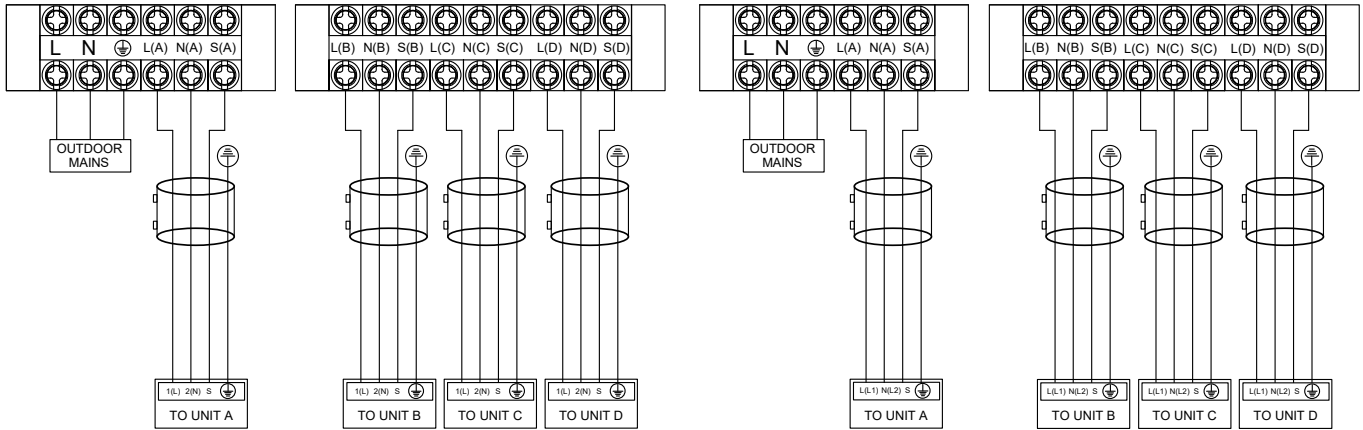

MRC-110AS-5 and MRC-135-5 Connecting Diagram

Serene / Mini Cassete

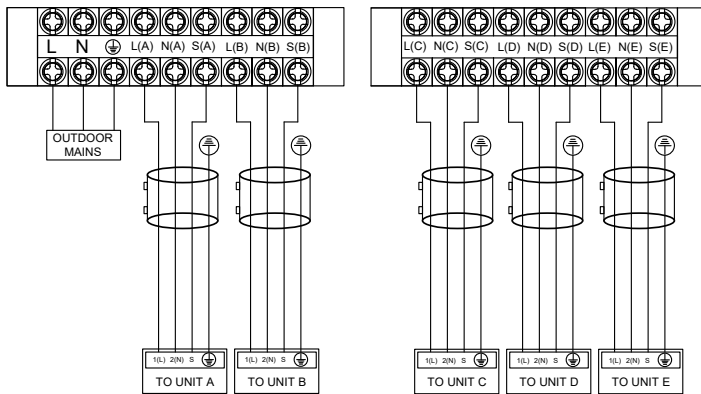

Magnetic Ring (supplied, on selected outdoor models). Clip this around the connecting wires during installation.

Bulkhead

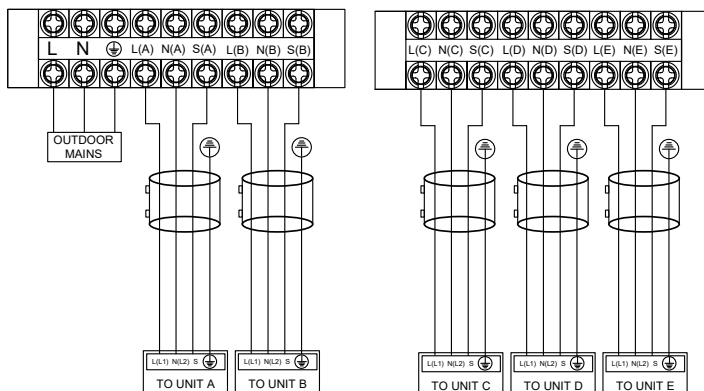

! CAUTION

After the confirmation of the above conditions, prepare the wiring as follows:

- Separate isolator (sub-circuit) must be installed for each air-conditioning system. Make sure to follow the wiring diagram provided with unit (back of control cover).
- During transport, screws in terminal block may become loose due to handling and vibrations. Check the connections and tightened the screw if necessary.
- Ensure the voltage supply is within the required specification 230VAC (-6%/+10%) .
- Suggested minimum cable size should be used as a guide only, refer to AS/NZS 3000 "Australian/New Zealand Wiring Rule" for more details.

Circuit Breaker Size & Amps (Main Power Supply)

1. Compute the total FLA of all the installed equipment (outdoor + the combined indoor units) using the table below:

Example: MRC-135AS-5 + 2x WRE-026AS + 2x BRE-035BS + 1x MRE-035AS

$$\text{Total System FLA} = 25.8 + 2(0.24) + 2(1.2) + 1(0.57) = 29.25A$$

Full Load Amps Table

Model	MRC-052AS-2	MRC-071AS-3	MRC-100AS-4	MRC-110AS-5	MRC-135AS-5
FLA (Outdoor Unit)	14.0	15.8	16.0	21.0	25.8
Model	WRE-026AS	WRE-035AS	WRE-050AS	WRE-071AS	BRE-026BS
FLA (Indoor Unit)	0.24	0.275	0.275	0.4	1.2
Model	BRE-035BS	BRE-050BS	BRE-071BS	MRE-035AS	MRE-0520AS
FLA (Indoor Unit)	1.2	1.5	1.5	0.57	0.57

2. From the calculated system total FLA, use the table below to determine cable sizes and system circuit breaker size:

Example: Total System FLA = 28.71A will require 6.0mm (Supply Mains), 1.0mm (OD to ID wire) and 32A CB fuse.

	Total FLA Range	20A and less	>20A to 25A	>25A to 32A
Outdoor Unit Cable Size (Supply Mains)		2.5	4.0	6.0
Indoor Unit Cable Size (Outdoor to Indoor wire)		1.0	1.0	1.0
Circuit Breaker Size		20A	25A	32A

NOTES: Cable sizes are suggested minimum and should be used as a guide only.

Refer to AS/NZS 3000 "Australian Wiring Rules" for more details.

Wires, circuit breaker and fuses are NOT supplied with the units, installer has to provide.

- ① MAINS WIRING (220-240VAC)
(Single Phase + Neutral) 50Hz
- ② CONTROL WIRING (220-240VAC)
(Single Phase + Neutral) 50Hz
- - - - ③ EXTRA LOW VOLTAGE DATA CONTROL WIRING
2 core shielded data cable 14/0.20 (0.44mm²)
maximum 65 metres
- ④ EXTRA LOW VOLTAGE DATA CONTROL WIRING
4 core shielded data cable (0.75mm²)
maximum 12 metres

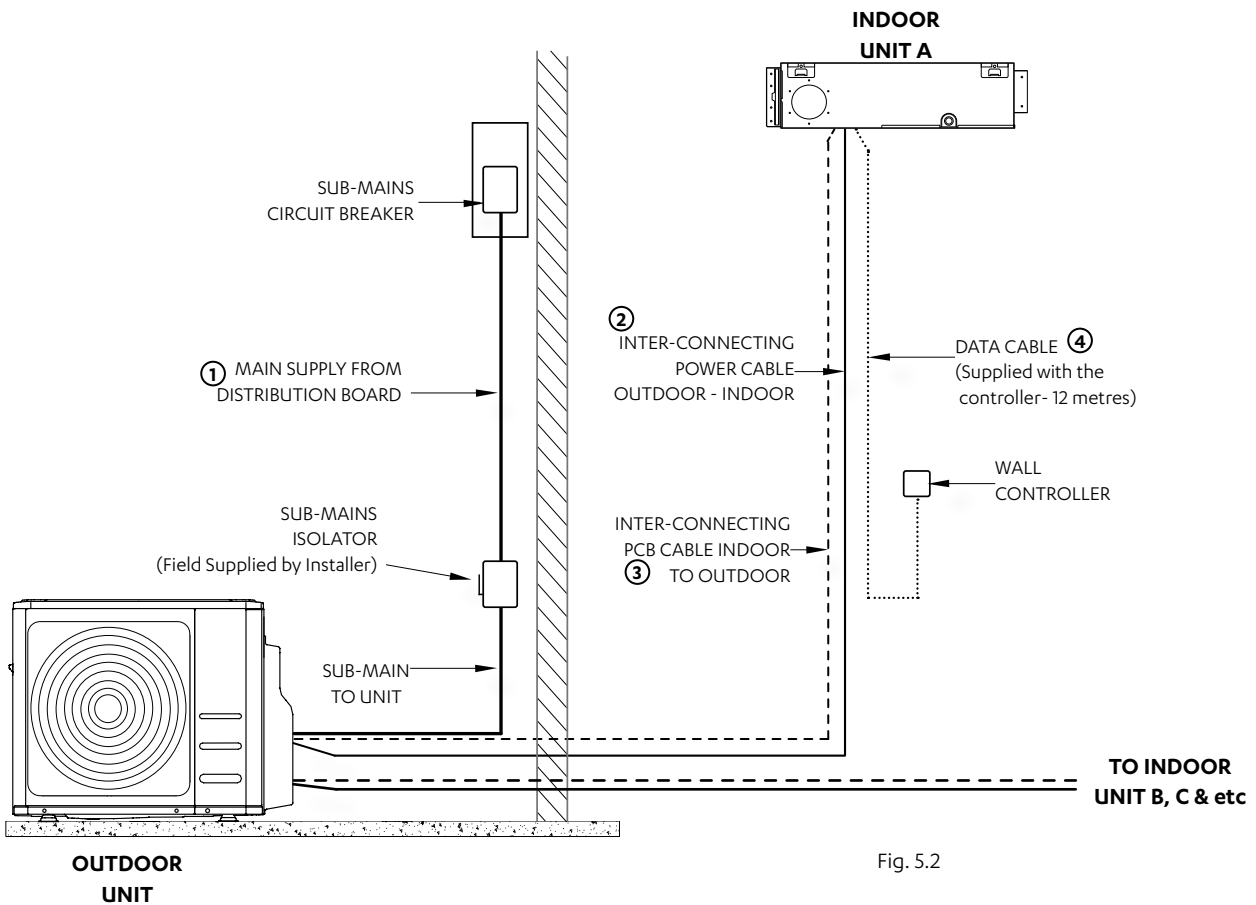

Fig. 5.2

Leak Test

NOTE

Leak testing and evacuation must be conducted on each circuit with connected indoor unit.

1. Run interconnecting pipe work from condenser to evaporator.
2. Connect the liquid and suction pipe to the indoor and outdoor unit flare connections (please see refrigerant piping connection instruction).
3. Fit service gauge to the service port on the outdoor unit.
4. Fit a nitrogen to the service gauge.
5. Pressurise the system to 4000kPa. A recommended pressure test is to be performed for no less than 1 hour at 4000kPa Bubble test system and ensure pressure does not drop during this time.
6. Repeat the process for the rest of the connected indoor units.

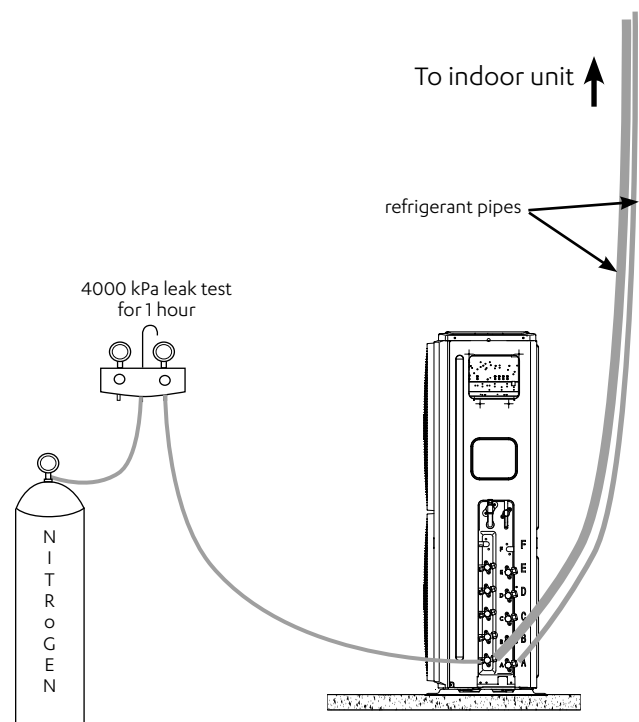

Fig. 6.1

Evacuation Instructions

! CAUTION

- Use a vacuum pump and a vac stat reading lower than 500 microns and an air discharge capacity above 40L/min.
- The outdoor unit does not need vacuuming **DO NOT** open the outdoor unit's gas and liquid stop valves.
- Ensure that your vac stat reads 500 micron or below after 2 hours. If after three hours of operation and the vac stat reading is still above 500 microns, re-pressurise system and check for a gas leak. If there is no leakage, perform another evacuation for 1 to 2 hours or until the vac stat reads 500 microns or below.
- **DO NOT** use refrigerant gas during a leak test of a system.

6. Leak Test and Air Evacuation

Multi Split System

Evacuation Instructions

Before using manifold gauge and vacuum pump, read their operation manuals to familiarize yourself with how to use them properly.

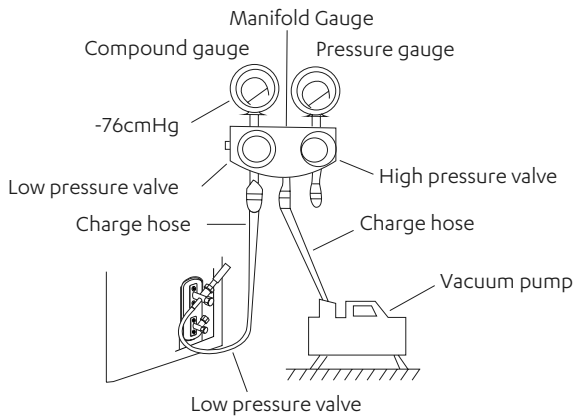

Fig. 6.2

1. Connect the charge hose of the manifold gauge to service port on the outdoor unit's low pressure valve.
2. Connect another charge hose from the manifold gauge to the vacuum pump.
3. Open the Low Pressure side of the manifold gauge. Keep the High Pressure side closed.
4. Turn on the vacuum pump to evacuate the system.
5. Run the vacuum until the vac stat reads 500 microns.
6. Close the Low Pressure side of the manifold gauge, and turn off the vacuum pump.
7. Wait for 5 minutes, then check that there has been no change in system pressure.
8. Insert hexagonal wrench into the packed valve (high pressure valve) and open the valve by turning the wrench in a 1/4 counterclockwise turn. Listen for gas to exit the system, then close the valve after 5 seconds.

9. Watch the Pressure Gauge for one minute to make sure that there is no change in pressure. The Pressure Gauge should read slightly higher than atmospheric pressure.
10. Remove the charge hose from the service port.
11. Using hexagonal wrench, fully open both the high pressure and low pressure valves.

! OPEN VALVE STEMS GENTLY

When opening valve stems, turn the hexagonal wrench until it hits against the stopper. **DO NOT** try to force the valve to open further.

12. Tighten valve caps by hand, then tighten it using the proper tool.
13. If the outdoor unit is not connected to all the valves, please ensure nuts which are not connected to an indoor are tight and have been leak tested correctly



Fig. 6.4

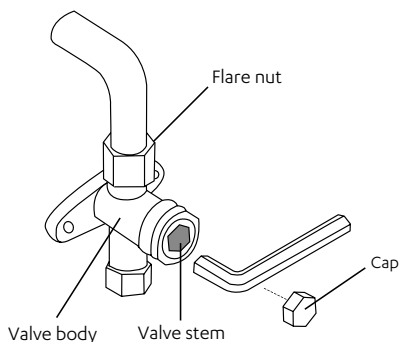

Fig. 6.3

Note on Adding Refrigerant

! CAUTION

- Refrigerant charging must be performed after wiring, pressure test and evacuation.
- **DO NOT** exceed the maximum allowable quantity of refrigerant or overcharge the system. Doing so can damage or impact the unit's function.
- Charging with unsuitable substances may cause explosions or accidents. Ensure that the appropriate refrigerant is used.
- Refrigerant containers must be opened slowly. Always use protective gear when charging the system.

Refrigerant Charge Details (Table 6.1)

Model	MRC-052AS-2	MRC-071AS-3	MRC-100AS-4	MRC-110AS-5	MRC-135AS-5
Refrigerant Type	R410A				
Refrigerant Charge (grams)	2150	2620	3300	3980	4980
Pre-charged Length (metres)	10m per connected ID unit				
Additional Refrigerant per meter (grams/metres)	15			15	
Liquid Pipe	2 x 6.35mm (1/4")	3 x 6.35mm (1/4")	4 x 6.35mm (1/4")	5 x 6.35mm (1/4")	5 x 6.35mm (1/4")
Gas Pipe	2 x 9.52mm (3/8")	3 x 9.52mm (3/8")	3 x 9.52mm (3/8") + 1 x 12.7mm (1/2")	4 x 9.52mm (3/8") + 1 x 12.7mm (1/2")	3 x 9.52mm (3/8") + 2 x 12.7mm (1/2")

Electrical Safety Test

Perform the electric safe check after completing installation:

1. Insulated resistance
The insulated resistance must be more than $2M\Omega$.
2. Grounding work
After Finishing grounding work, measure the grounding resistance by visual detection and grounding resistance tester. Make sure the grounding resistance is less than 4Ω .
3. Electrical leakage check (performing during test running)
During test operation after finishing installation, the service technician can use the multimeter to perform the electrical leakage check. Turn off the unit immediately if fault found rectify etc;

NOTE

The illustration is for explanation purpose only. The actual order of A, B, C, D and E on the machine may be slightly different from the unit you purchased. The actual shape shall prevail.

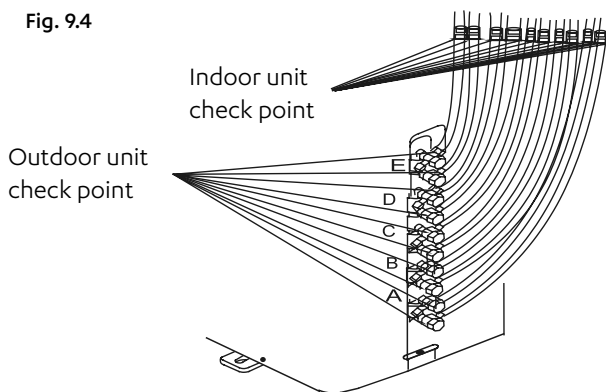

A, B, C, D are points for one-four type.
A, B, C, D, E are points for one-five type.

Before Test Run

A test run must be performed after the entire system has been completely installed. Confirm the following points before performing the test:

- a. The indoor and outdoor units are properly installed.
- b. Piping and wiring are properly connected.
- c. Ensure that there are no obstacles near the inlet and outlet of the unit that might cause poor performance or product malfunction.
- d. The refrigeration system does not leak.
- e. The drainage system is unimpeded and draining to a safe location.
- f. The heating insulation is properly installed.
- g. The earth wires are properly connected.
- h. The length of the piping and the added refrigerant stow capacity have been recorded.
- i. The power voltage is the correct voltage for the air conditioner.

CAUTION

Failure to perform the test run may result in unit damage, property damage or personal injury.

Test Run Instructions

1. Open both the liquid and gas stop valves.
2. Turn on the main power switch and allow the unit to warm up.
3. Set the air conditioner to COOL mode.
4. For the Indoor Unit
 - a. Ensure the wired and/or remote control and its buttons work properly.
 - b. Ensure the louvres move properly and can be changed using the remote control.
 - c. Double check to see if the room temperature is being registered correctly.
 - d. Ensure the indicators on the wired and/or remote control and the display panel on the indoor unit work properly.
 - e. Ensure the manual buttons on the indoor unit works properly.

Test Run Instructions (continued)

5. For the Outdoor Unit
 - a. Check to see if the refrigeration system is leaking.
 - b. Make sure there is no vibration or abnormal noise during operation.
 - c. Ensure the wind, noise, and water generated by the unit do not disturb your neighbours or pose a safety hazard.

NOTE

If the unit malfunctions or does not operate according to your expectations, please refer to the Troubleshooting section of the Owner's Manual before calling customer service.

Automatic Wiring/Piping Correction Function

New product is capable of automatic correction of wiring/piping error. Press the “check switch” on the outdoor unit PCB board for 5 seconds until LED display “CE”, then wait approximately 5-10 minutes after the switch is pressed, the “CE” will then disappear and the wiring/piping error will be corrected, and wiring/piping will be properly connected.

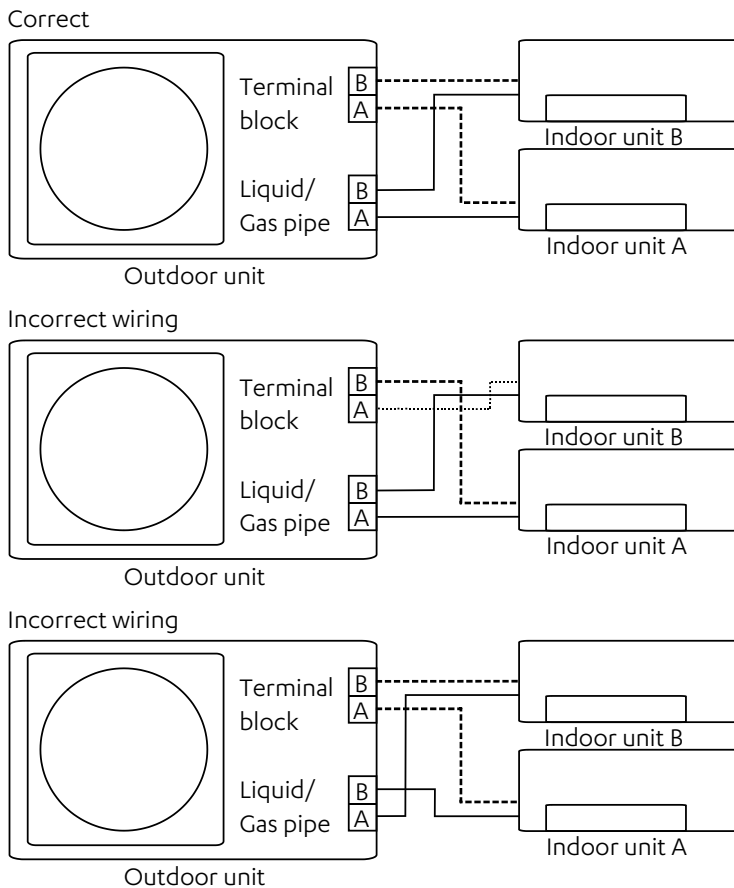
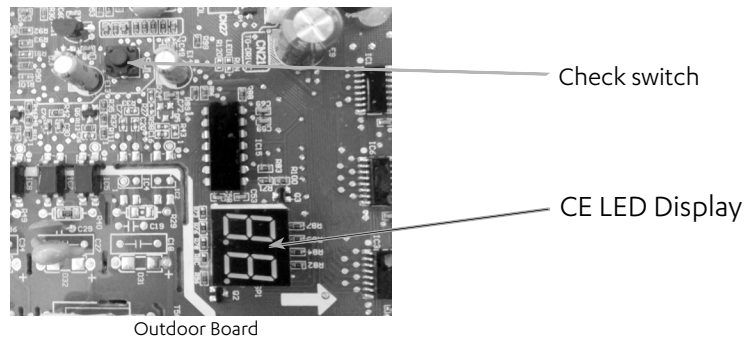

How to activate this function

1. Check the outside temperature is above 5° C degrees.
(This function does not work when outside temperature is not above 5° C)
2. Check that the stop valves of the liquid pipe and gas pipe are open.
3. Turn on the breaker and wait at least 2 minutes.
4. Press the check switch on the outdoor PCB board unit LED display “CE”.
5. If the display changes from “CE” to “CF”, a detection error has occurred. You are advised to re-do the auto correction function or check the wiring and pipe connections.

Maintenance Procedures

This section describes the procedures that must be performed as a part of normal maintenance program. Regular servicing of equipment by licensed HVAC technician is highly recommended. Always disconnect electrical power to the unit before performing these procedures. It is always a safe practice to observe all safety warnings and cautions when conducting maintenance tasks.

DANGER

Live Electrical Connections !

It may be necessary to work with live electrical components on certain maintenance tasks. Only licensed electricians and qualified technicians are allowed to perform these tasks.

WARNING

Hazardous Voltage !

Always make sure that all power supply, including remote controls, are disconnected before performing maintenance. Observe proper Lock-Out / Tag-Out procedures to ensure that power cannot be inadvertently energised. Failure to disconnect power before maintenance procedures can result in serious injury and/or death.

Annual Maintenance Checklists

- Perform general maintenance inspections.
- Perform scheduled start-up checks.
- Leak test refrigerant circuits.
- Inspect contacts of all contactors and relays. Replace all worn contacts as required.
- Inspect, clean and tighten all electrical connections.
- Check fans for balanced operation. Make sure that there are no loose screws/bolts, no fan blades interference and no damage to the fans and guards.
- Inspect the air filters, clean or replace as required.
- Clean and repaint any corroded panel section.
- Ensure no blockage of airflow through variable speed drive and drive fan is operating correctly.

Cleaning the Condenser Coils

Clean the coils at least once a year or more frequently if unit is located in a dusty and dirty environment, in order to maintain your system's proper operating performance. High discharge pressures are good indication that the coils need cleaning. When using detergent or solvents to clean the coils, follow the manufacturer's instructions to avoid potential damage to the coils and to the unit.

To clean the refrigerant coils, use a soft brush and water spray, such as garden hose or pressure washer with low pressure nozzle.

DANGER

Beware of Rotating Fan Blades !

- Always make sure that all power supply, to the Outdoor Fans are turned-off and isolated.
- Observe WH&S safety procedures, do not wear loose clothing and any jewellery when working near the fans.
- Wear PPE whenever performing any maintenance procedures.
- Observe all necessary procedures when working on a confined space.

CAUTION

Do Not Use High Alkaline Detergent !

When using detergent for coil cleaning, ensure that the alkaline level is no higher than 8.5, which can cause corrosion damage to the coils.

Coil Cleaning Procedures

- Disconnect power to the unit.
- Remove the louvered panels from the unit to gain access to the air inlet side of the coils.
- Use a soft brush to remove loose dirt and debris from both sides of the coils.
- Straighten bent coil fins with fin comb.
- Prepare the detergent solutions according to the manufacturer's instructions.
- Spray solution at a 90° angle to the coils, keeping a minimum nozzle spray angle of 15°, with at least a 1800mm distance from the coils and 600 psi pressure.
- Spray leaving air side of the coils first then the air inlet side. Allow the solution to stand on the coils for five minutes.
- Rinse both sides of the coils with cool clean water.
- Inspect the coils, if they are still dirty, repeat the cleaning procedure.
- Clean and wipe dry the outer and inner sides of the unit, the refrigerating parts and other components.
- Ensure that the condensate drain lines are not blocked.
- Reinstall all unit panels, covers and guards.
- Restore electrical power to the unit.

10. Maintenance

Multi Split System

Electrical											
Parts	Service Frequency					Detail of Service Check	Service Methods				
	1 Mth	3 Mth	6 Mth	1 Yr	2 Yrs			3 Yrs	4 Yrs	5 Yrs	
Printed Circuit Boards				✓						Visual Inspection.	Tighten Terminals as necessary on printed circuit boards.
Electrical Connections				✓						Check all electrical terminals, mains, communications, etc.	Re-tighten if loose.
Magnetic Contactor				✓						Check for loose terminal connections.	Tighten electrical terminals. Remove any dust.

Indoor Unit											
Parts	Service Frequency					Detail of Service Check	Service Methods				
	1 Mth	3 Mth	6 Mth	1 Yr	2 Yrs			3 Yrs	4 Yrs	5 Yrs	
Casing/Panels and Frames				✓						Visual check for damage, rust and dust accumulation.	For highly corrosive environment, wash panels quarterly with water & neutral detergent solution. Wax panels. Repair / re-paint where required.
Insulation				✓						Visual check for insulation conditions.	Repair / replace insulation material.
Fan				✓						Visual check for run out of balance and dust attached.	Clean off dust as necessary to negate possibility of fan running out of balance.
Motor				✓ Ω						Visual check on wiring. Insulation resistance check to be carried out annually.	Measure insulation resistance to earth with Megger. Insulation resistance should be more than 1MΩ.
"Heat Exchanger"				✓						Check for clogging by dust. Check for leaks / damage.	Clean air inlet side as necessary. Straighten any bent fins using fins comb.
Drain Pan/ Condensation line				✓						Check for obstructions & free flow of water.	Clean to eliminate obstructions/ sludge & check condition of pan. Pour water to ensure free flow.
Filter*			✓							Check for clogging by dust.	Clean / Replace Filter.
Temperature Readings				✓						Measure air on & air off.	Place temperature probe in return & supply air of unit.

*Service period for filter cleaning may vary depending on operating time & surrounding environment

10. Maintenance

Multi Split System

Outdoor Unit										
Parts	Service Frequency					Detail of Service Check	Service Methods			
	1 Mth	3 Mth	6 Mth	1 Yr	2 Yrs			3 Yrs	4 Yrs	5 Yrs
Casing/Panels and Frames				✓					Visual check for damage, rust and dust accumulation.	For highly corrosive environment, wash panels quarterly with water & neutral detergent solution. Wax panels. Repair / re-paint where required.
Insulation				✓					Visual check for insulation conditions.	Repair / replace insulation material.
Fan			✓						Visual check for run out of balance and dust accumulation.	Clean off dust as necessary to negate possibility of fan running out of balance.
Motor				✓ Ω					Visual check on wiring. Insulation resistance check to be carried out annually.	Measure insulation resistance. Should be more than 1MΩ.
"Heat Exchanger"				✓					Check for clogging by dust. Check for leaks / damage.	Clean air inlet side as necessary. Straighten any bent fins using fins comb.
Condensate Drain Line (if available)				✓					Check for obstructions & free flow of water.	Clean to eliminate obstructions/sludge & check condition of drain line. Pour water to ensure free flow.
Compressor				✓ Ω					Check for high / low pressure. Measure insulation resistance. Check compressor for abnormal noise/vibrations.	Measure insulation resistance. Should be more than 1MΩ. Ensure to isolate first the VSD from the compressor before measuring insulation resistance.
Compressor drive				✓					For variable drive compressor check full operation of drive from minimum hertz to maximum, check fan operation of drive.	Check compressor amperage & running frequency feedback from outdoor board seven segment display.
				✓					Ensure drive fresh air path is clear and drive fan is operating correctly.	Check ventilation holes on top and bottom of drive cover are clear of leaves, pebbles or dirt.
Refrigeration Operational Readings				✓					Make note of operational reading in test cool/heat mode.	Check operating pressures, record super heat & sub-cool values.
"Safety Devices"				✓					Check calibration of safety devices.	Check resistance of sensors, pressure cut in / cut out of pressure controls.
Faults				✓					Check for any previous fault history on unit.	Investigate any causes for previous faults, reset fault history.

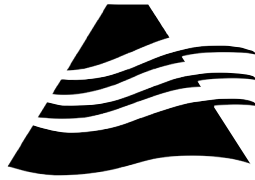

ActronAir

actronair.com.au

1300 522 722