

Cascade Series 2

Four Way Cassette

Installation and Commissioning Guide



Model Numbers

CRC-100CS / CRE-100CS

URC-125CS / CRE-125CS

URC-140CS / CRE-140CS



IMPORTANT NOTE:

Please read this manual carefully before installing or operating your air conditioning unit. Make sure to save this manual for future reference.



CAUTION:

The system is charged with flammable refrigerant, safety checks are necessary to ensure that the risk of ignition is minimised.



Table of Contents

01. Symbols	3
02. Inspection	3
03. General Information	3
04. Safety Instructions	4
05. Installation Information	5
06. Components	7
07. Installation Overview	8
08. Indoor Units Parts	9
09. Indoor Unit Dimensions	10
10. Indoor Unit Installation	11
11. Indoor Drainpipe Installation	15
12. Outdoor Unit Installation	18
13. Refrigerant Piping Connection	21
14. Wiring	26
15. Electrical Wiring	28
16. Wiring Diagram	30
17. Air Evacuation	32
18. Electrical and Gas Leak Checks	34
19. Installation of the Panel	35
20. Test Run	38
21. Maintenance	40
22. Maintenance Frequency Checklist	41

This manual is a controlled document which contains confidential and proprietary information. Distribution, modification, copying and/or reproduction are prohibited without written consent from ActronAir

Product design and specifications are subject to change without prior notice for product improvement. Drawings are for illustration purposes only and may vary depending on the model purchased.

READ SAFETY PRECAUTIONS

Incorrect system operations due to ignoring instructions can cause serious damage or injury. The seriousness of potential damage or injuries is classified as either a **WARNING** or **CAUTION**.



CAUTION

Failure to observe a caution may result in injury or equipment damage.



WARNING

Failure to observe a warning may result in death or serious injury.





FOR COMPLIANCE WITH QUEENSLAND
ELECTRICAL SAFETY REGULATIONS 2013
This refers to electrical works only



MUST BE INSTALLED BY A LICENSED
ELECTRICIAN

01. Symbols

Explanation of symbols displayed on the air conditioner. Information About This Guide

	This symbol shows that this appliance uses a flammable refrigerant. If the refrigerant leaks and is exposed to an external ignition source, there is a risk of fire.
	This symbol shows that the Operation Manual should be read carefully.
	This symbol shows that a service person should be handling this equipment with reference to the Installation Manual.
	This symbol shows that there is information included in the Operation Manual and Installation Manual.

02. Inspection

02.01. Product Inspections

Check your air conditioning unit and all items against the invoice upon receiving your shipment. Inspect the unit, components and accessories for any sign of damage. If there is any damage to the unit, contact ActronAir Customer Care Department immediately on: **1300 522 722** to obtain a Goods Return Number.

Check the unit nameplate to verify the model, serial number, electrical rated specifications are correct.

02.02. Codes, Regulations and Standards

The installer and/or contractor assumes responsibility to ensure that unit installation complies with the relevant council, state / federal codes, regulations and building code standards. All electrical wiring must be in accordance with current electrical authority regulations and all wiring connections to be as per electrical diagram provided with the unit.

03. General Information

The ActronAir air conditioning units are designed for applications where superior performance, high efficiency, reliability, supply air quality and quiet operation are the prime priorities.

For optimum efficiency, your air conditioning unit will deliver just the right amount of cooling or heating capacity you demand.

Energy Efficient Refrigeration Circuits

The ActronAir system is designed with a split ducted refrigeration circuit that delivers only the amount of cooling or heating actually required to maintain your desired comfort at the most optimum efficiency.

Each refrigeration circuit consists of:

- High efficiency inverter rotary compressor.
- Gold hydrophilic coat coil protected condenser designed for optimum performance and efficiency with corrugated fins and ruffled tubing.
- Gold hydrophilic coat coil protected evaporator coil designed for optimum performance and efficiency with lanced fins and ruffled tubing.

Evaporator Section

The evaporator section has DC fans which deliver just the right amount of airflow, depending on requirements. The fans provide superior performance for your comfort at optimum efficiency:

- Highly efficient variable speed DC motor that uses less energy.
- Easy variable indoor fan commissioning via intelligent controllers.
- Low noise operation.

Condenser Section

Includes DC inverter fan motor, with the following features:

- Low noise operation.
- Inverter rotary compressor.

Electrical Section

The electrical section is composed of a separate panel for controls, protecting the components from the elements.

Durable Design and Construction

ActronAir is an Australian manufacturer with proven high quality air conditioning products. Known for their durability and reliable performance, these products are designed and built to withstand the extreme weather conditions utilising galvanized steel cabinet, with powder coated epoxy enamel finish.

Gold Hydrophillic Coat Coil Protection heat exchangers ensures an enhanced heat transfer with increased performance efficiency.

System Flexibility

The ActronAir air conditioning units are suitable for residential, office, schools and other air conditioning facilities applications, both for new construction or retrofitting projects.

Refrigerant Handling and Accountability

ActronAir strongly urges that all service technicians make every effort to eliminate the emission of refrigerants to the atmosphere. Everyone must act in a responsible manner to conserve refrigerants.

Sustainability and Environmentally Friendly

The air conditioning system is supplied with a zero ozone depleting low GWP R-32 refrigerant, which has no phase out or replacement concern.

With cooling and heating performance capacity that are among the best in the market, the ActronAir air conditioning units provide the solution for the reduction of energy consumption, CO₂ emission, high fuel dependency and high network grid demand.

04. Safety Instructions

- Only licensed HVAC technicians* should install and service this air conditioning equipment. Improper service or alteration by an unqualified technician could result in significant and major damage to the product or property which may render your warranty null and void. Such unqualified service could also lead to severe physical injury or death. Follow all safety instructions in this literature and all warning labels that are attached to the equipment.
 - Prevailing WH&S regulations must be observed and will take precedence to the safety instructions contained on this manual. Safe work practices and environment must be the paramount importance in the performance of all the service procedures.
 - Ensure that unit installation complies with relevant council regulations and building code standards.
 - All electrical wiring must be in accordance with current electrical authority regulations and all wiring connections to be as per electrical diagram provided.
 - Secure the fans against accidental contact. Beware of pinch point and sharp edges which can cause cutting injury.
 - Always wear appropriate PPE, remove any dangling jewellery and protect long hair by wearing a cap.
 - Make sure that safety guards and panel covers are always firmly secured and not damaged.
 - This appliance is not intended for use by young children or infirm persons unless they have been adequately supervised by a responsible person to ensure that they can use the appliance safely. Young children should be supervised to ensure that they do not play with the appliance.
 - Installer must incorporate a means of electrical disconnection (isolator) in the sub mains fixed wiring in accordance with the latest version of the AS/NZS 3000 (also known as Australian Wiring Rules).
 - Secure the power cords and control cables that goes in/out the unit.
- *Qualifications required will be appropriate Electrical, Refrigeration and Refrigerant Handling License and Training dependent on local State/Territory regulations.

 **DANGER****Hazardous Voltage - Risk of Electrocutation.**

Turn Off the power from main isolator before proceeding with any service work of the unit. Observe proper LOCK-OUT/TAG-OUT (LOTO) procedures for electrical appliances in order to prevent accidental switching-on of the power supply. Extreme care and caution must be observed should there be a need to work on live circuit.

 **WARNING**

This air conditioning unit contains R-32 refrigerant (CLASS A2L) which is mildly flammable. Thoroughly read and understand the accompanying **R-32 Safety Guide** for installation and maintenance instructions. Installation, service, maintenance, repairs and decommissioning of this unit must be performed by a licensed HVAC technician; qualified to handle R-32 refrigerant.

R-32 refrigerant is odorless if the refrigerant gas comes into contact with fire, it may emit a poisonous gas.

Appliance shall be installed, operated and stored in a well ventilated area:

- where the room size corresponds to the room area as specific for operation.
- without continuously operating open flames (for example an operating gas appliance) and ignition sources (for example an operating electric heater).
- away from other potential continuously operating sources that known to cause ignition of R-32 refrigerant.

 **CAUTION****Beware of Rotating Fans!**

Ensure that indoor and outdoor fans are isolated and have come to a complete stand still before servicing the equipment.

Beware of pinch point and sharp edges which can cause cutting injury. Secure the fans against accidental contact.

Always wear appropriate PPE and remove any dangling jewellery and protect long hair by wearing a cap. Ensure that no loose clothing can be caught / entangled in moving parts.

VISUAL INSPECTION AND WORK ASSESSMENT

Work areas and conditions must first be assessed and evaluated for any potential hazardous conditions. It is also important to be familiar with the unit parts and components before proceeding with any service task.

NOTE**Fuse Specifications**

The air conditioner's circuit board (PCB) is designed with a fuse to provide over current protection. The fuse specifications, **T3.15A/250VAC** is printed on the circuit board

For the units with R-32 refrigerant , only the blast-proof ceramic fuse can be used.

05. Installation Information

All service technicians handling this unit must be licensed to handle R-32 refrigerant.

Recover and Recycle Refrigerants

Never release refrigerant to the atmosphere! It is an offence in Australia to do so. Always recover, recycle and reuse refrigerants. When removing from the system, properly contain and identify refrigerants in its dedicated container for proper disposal and/or storage. Always consider the recycle or reclaim requirements of the refrigerant before beginning the recovery procedures. Obtain a chemical analysis of the refrigerant if necessary. For the recovered refrigerant and acceptable refrigerant quality refer to the existing standards and regulations.

Refrigerant Handling and Safety

Consult the refrigerant manufacturer's Material Safety Data Sheet (MSDS) for information on proper handling and to fully understand health, safety, storage and disposal requirements. Use the approved containment vessels and refer to appropriate safety standards. Comply with all applicable transportation standards when shipping refrigerant containers.

Service Equipment and Recovery Procedures

Always use refrigerant reclaiming equipment in order to minimise refrigerant emissions. Use equipment and methods which will pull the lowest possible system vacuum while recovering and condensing refrigerant. Equipment capable of pulling a vacuum of less than 500 microns is required.

Do not open the system to the atmosphere for service work until refrigerant is fully removed and/or recovered. Perform refrigeration system evacuation, prior to charging, in accordance with AIRAH / IRHACE Refrigerant handling code of practice.

Let the unit stand for 1 hour and with the vacuum not rising above 500 microns. A rise above 500 microns indicates a leak from the system and a leak test is required to locate and repair any leak.

Charge refrigerant into the system only after the equipment does not leak or contain moisture. Take into consideration the correct amount of refrigerant charge specified for the system to ensure efficient unit operations. When charging is complete, reclaim refrigerant from charging lines into an approved refrigerant container. Seal all used refrigerant containers with approved closure devices to prevent unused refrigerant from escaping to the atmosphere. Take extra care to maintain all service equipment directly supporting refrigerant service work such as gauges, hoses, vacuum pumps and recycling equipment.

INSTALLATION PREPARATION (Pre-Installation considerations)

The following items must be considered before beginning the unit installation:

- Verify the unit capacities and ratings with the unit nameplate.
- Make certain the floor or foundation is level, solid and has sufficient structural strength to support the unit and accessories weight.
- Install anti-vibration rubber (installer to supply) under **all of the unit's feet** to help reduce noise and minimize vibration transfer through the foundation. Ensure that all anti-vibration rubbers are rated to provide stable support without impairing the unit's structural integrity.
- Diameter or width of anti-vibration rubber's must be at least equal to the width of the actual feet to prevent deformation overtime.
- Allow minimum recommended clearances for periodic maintenance and service access.
- Allow sufficient space beside the unit for the outdoor air discharge. Condenser air inlet, located on the coil side of the unit, requires sufficient airflow clearance for the optimum unit performance.
- Note the conditioned supply air and return air location. Ensure sufficient spaces are allocated for these purposes.
- For the connection and location of condensate drain in the unit, refer to the drawings and dimensions section of this manual.
- Wiring connections must be in accordance with the wiring diagram provided with the unit.
- Make sure all wirings are in accordance with local electricity authority regulations and standards.
- Do not install the unit close to an area where there is a danger of fire due to volatile, explosive, flammable and/ or hazardous materials.
- Ensure that spaces around the unit are free from any obstructions for optimum unit performance.
- Installer to ensure correct size/type that main circuit breaker and cable is installed in unit sub-mains to protect the sub-mains and unit wiring.
- Installer to ensure correctly rated residual current device (RCD) is installed as per the latest version of the AS/NZS 3000 (also known as Australian Wiring Rules).

CAUTION

This indoor unit is designed to match only with the ActronAir outdoor unit as specified in the Technical Selection Catalogue. The unit is supplied with factory charged R-32 refrigerant and is designed for use with R-32 refrigerant only. Be aware of all the relevant regulations concerning the handling of refrigerant.











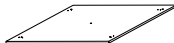

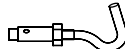
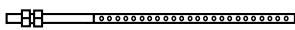

Optional accessories

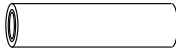
A wired controller is supplied with the unit. Alternately, there are two other ways to control the unit: wireless controllers and mobile devices via Easy Connect wifi connection. Select the controller based on customer preferences and requirements and install in an appropriate place as required.

Refer to catalogues and technical literature for guidance on selecting a suitable remote controller

06. Components

The indoor air conditioning system comes with the following components. Use the installation parts and accessories to install the air conditioner. Improper installation may result in water leakage, electrical shock and fire, or cause the equipment to fail. The items that are not included with the air conditioner must be purchased separately.

	Name	Quantity	Illustration
Indoor Unit Installation	Installation paper template		1
Electrical Noise Filter	Magnetic Ring -one hitched on wired controller; -one hitched on Indoor and Outdoor connection wire		2
Refrigeration Fittings	Nut		2
Pipe Fittings	Outlet pipe sheath		2
Installation Accessory	Ceiling hook		4
	Suspension bolt		4
Drain Fittings (Indoor)	Drain Seal		1
	Drain joint		1
Drain Fittings (Outdoor)	Seal ring		1
	Drain Joint		1
Wired Controller	Wired controller		1
	Wired controller screws		2
	Wired controller manual		1
Others	Owner's manual		1
	Installation manual		1
	Safety Guide		1

07. Installation Overview

Installation Order

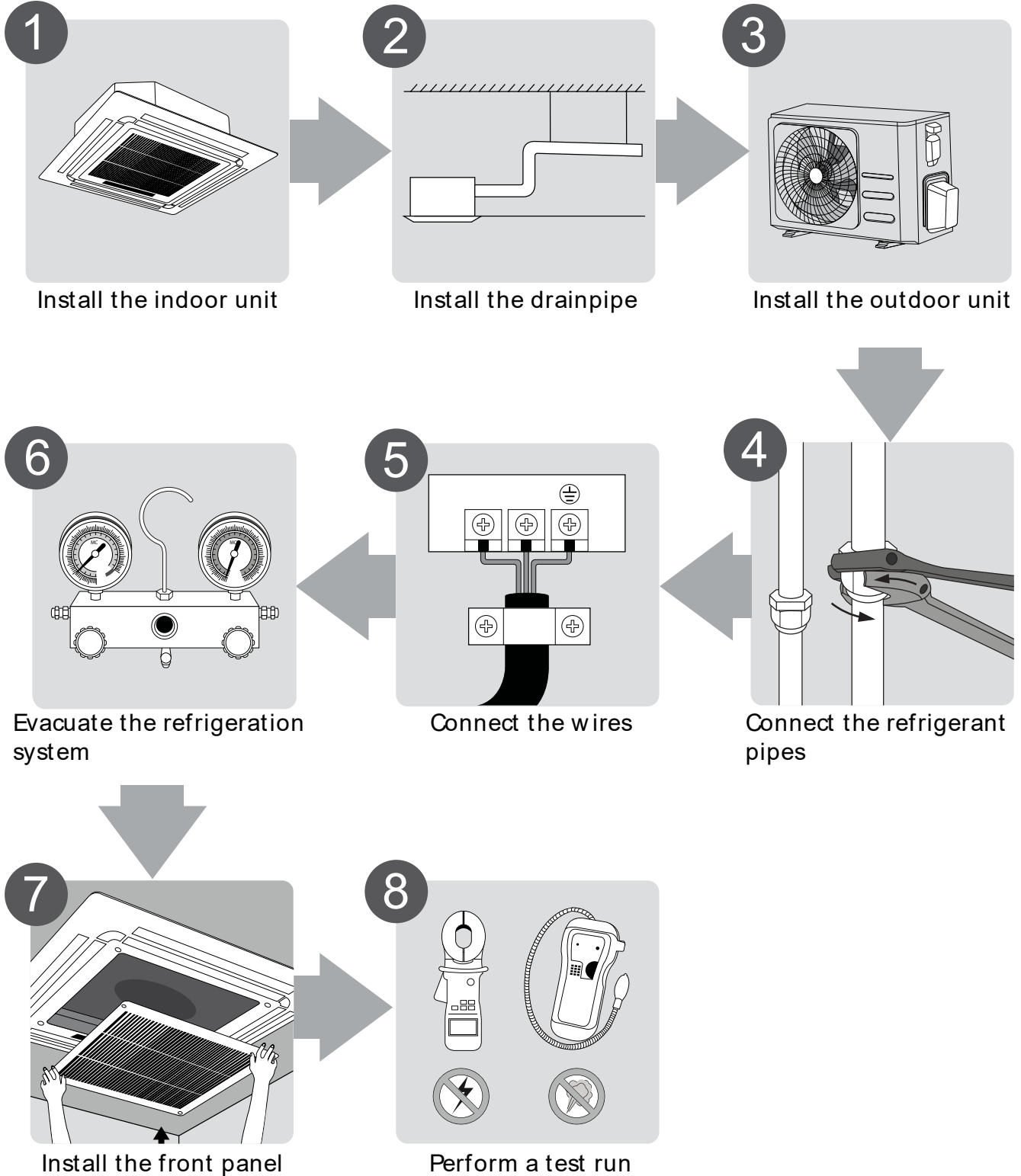

08. Indoor Units Parts

- ① Air outlet
- ② Air inlet
- ③ Front grille
- ④ Display panel
- ⑤ Remote controller
- ⑥ Drain pipe
- ⑦ Connecting pipe

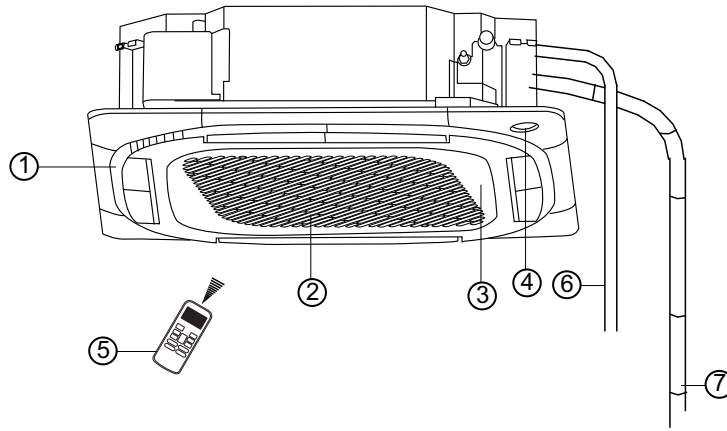

09. Indoor Unit Dimensions

Please refer to the following data to locate the four positioning screw bolt holes on the ceiling. Be sure to mark the areas where ceiling hook holes will be drilled.

The distance between the mounted indoor unit and the internal ceiling should meet the following specifications.

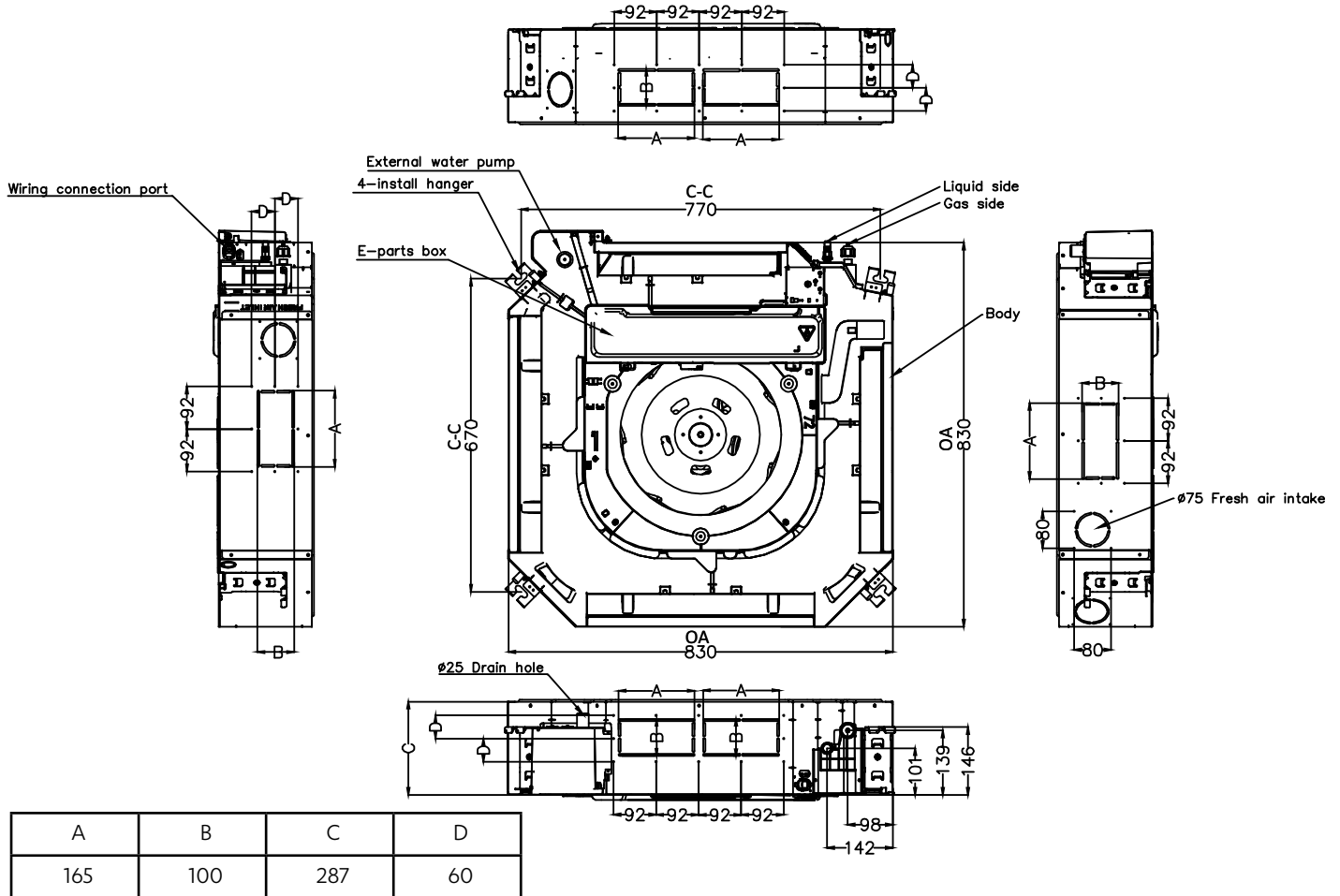

All dimensions are in mm.

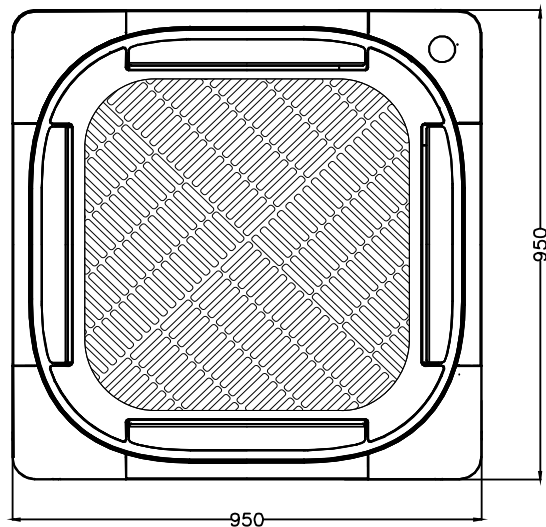

10. Indoor Unit Installation

WARNING

- Securely install the indoor unit on a structure that can sustain its weight. If the structure is too weak the unit may fall causing personal injury, unit and property damage or death.
- DO NOT install the indoor unit in the bathroom or laundry room as excessive moisture can short the unit and corrode the wiring.

CAUTION

- Install the indoor and outdoor units, cables and wires at least 1m from televisions or radios to prevent static or image distortion.
- DO NOT install the unit in the following locations:
 - In areas with oil drilling or fracking
 - In areas with caustic gases in the air, such as near hot spring
 - In enclosed spaces, such as cabinets
 - In areas with strong electromagnetic waves
 - In areas that store flammable materials or gas
 - In rooms with high humidity, such as bathrooms or laundry rooms

Select Installation Location

The outdoor unit should be installed in the location that meets the following requirements:

- There is enough room for installation and maintenance.
- There is enough room for the connecting pipe and drainpipe.
- The ceiling is horizontal and its structure can sustain the weight of the indoor unit.
- The air inlet and outlet are not impeded.
- The airflow can fill the entire room.
- There is no direct radiation from heaters.

Recommended Distances Between The Indoor Unit And The Ceiling

The distance between the mounted indoor unit and the internal ceiling should meet the following specifications.

(See Fig. 4.2)

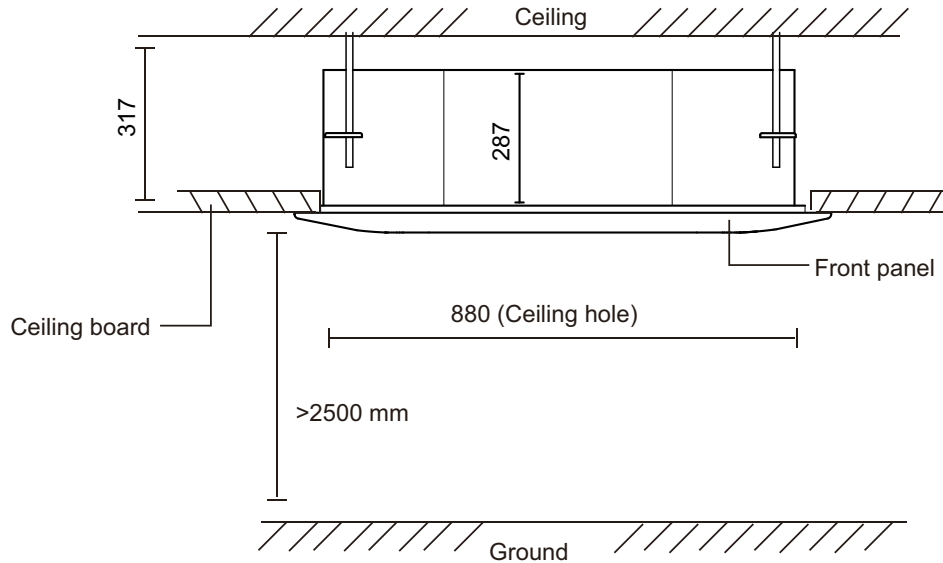

The service areas and airflow allowances mentioned are the minimum requirements to complete minor repairs. Additional space may be required should a major repair need to be undertaken.

Fig. 4.2

Hang Unit

1. Use the included paper template to cut a rectangular hole in the ceiling, leaving at least 1m on all sides. The hole should be 880x880mm. Be sure to mark the areas where ceiling hook holes will be drilled.

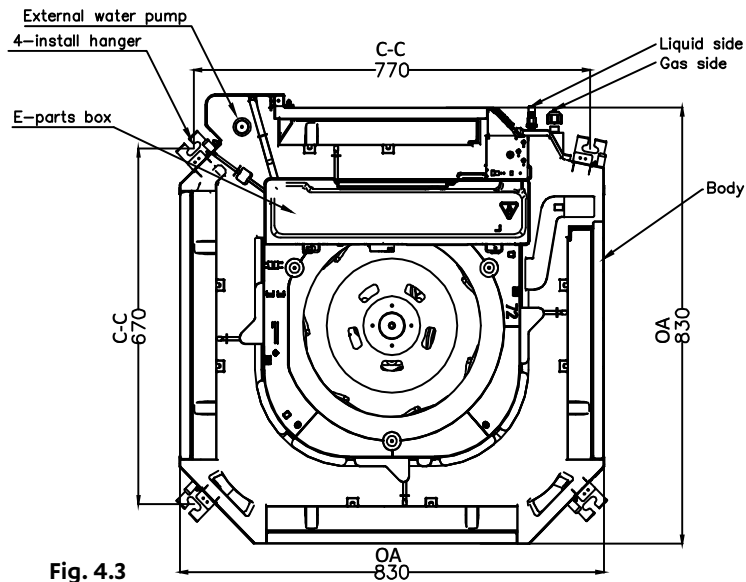

Fig. 4.3

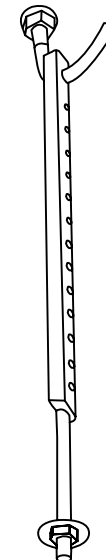

Fig. 4.4

2. Drill 4 holes 50mm deep at the ceiling hook positions in the internal ceiling. Be sure to hold the drill at a 90° angle to the ceiling.
3. Using a hammer, insert the ceiling hooks into the pre drilled holes. Secure the bolt using the included washers and nuts.

4. Install the four suspension bolts (See Fig. 4.4).

CAUTION

The unit body must be completely aligned with the hole. Ensure that the unit and the hole are the same size before moving on.

5. Mount the indoor unit. You will need two people to lift and secure it. Insert suspension bolts into the unit's hanging holes. Fasten them using the included washers and nuts (See Fig. 4.5).

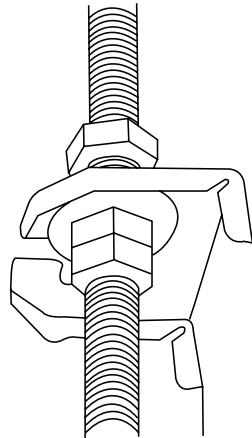

Fig. 4.5

NOTE

The bottom of the unit should be 24mm higher than the ceiling board. Generally, L (indicated in Fig. 4.6) should be half the length of the suspension bolt or long enough to prevent the nuts from coming off.

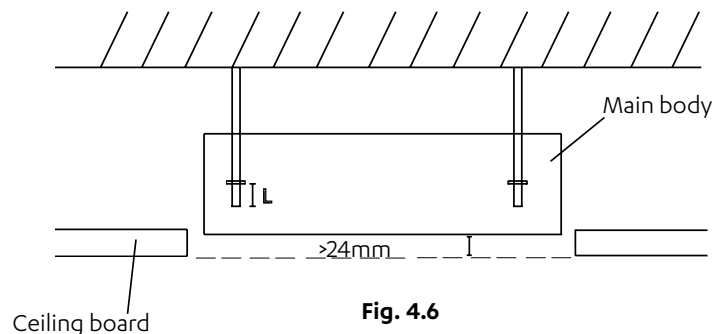

Fig. 4.6

CAUTION

Ensure that the unit is completely level. Improper installation can cause the drain pipe to back up into the unit or water leakage.

NOTE

Ensure that the indoor unit is level. The unit is equipped with a built-in drain pump and float switch. If the unit is tilted against the direction of condensate flows (the drainpipe side is raised), the float switch may malfunction and cause water to leak.

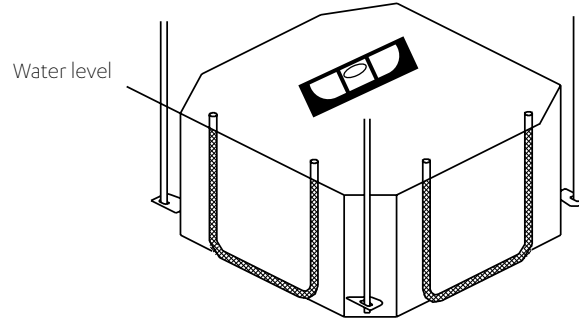
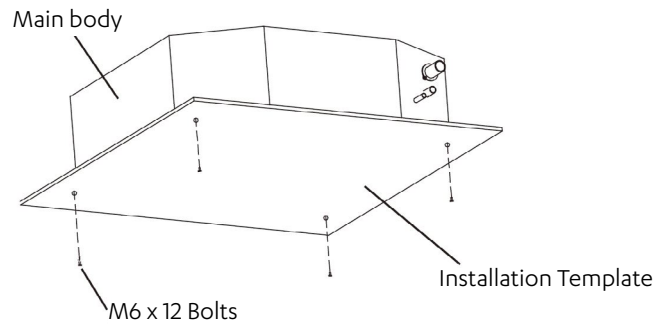

Fig. 4.7

NOTE FOR NEW HOME INSTALLATION

When installing the unit in a new home, the ceiling hooks can be embedded in advance. Make sure that the hooks do not come loose due to concrete shrinkage. After installing the indoor unit, fasten the installation paper template onto the unit with bolts (M6X12) to determine in advance the dimension and position of the opening on the ceiling. Follow the instructions above for the remainder of the installation.



11. Indoor Drainpipe Installation

The drainpipe is used to drain water from the unit. Improper installation may cause unit and property damage.

CAUTION

- Insulate all piping to prevent condensation, which could lead to water damage.
- If the drainpipe is bent or installed incorrectly, water may leak and cause a malfunction of the water-level switch.
- In **HEAT** mode, the outdoor unit will discharge water. Ensure that the drain hose is placed in an appropriate area to avoid water damage and slippage due to frozen drain water.
- **DO NOT** pull the drainpipe forcefully as this could cause it to disconnect.

Indoor Drainpipe Installation

Install the drainpipe as illustrated below.

1. Cover the drainpipe with heat insulation to prevent condensation and leakage.
2. Attach the mouth of the drain hose to the unit's outlet pipe. Sheath the mouth of the hose and clip it firmly with a pipe clasp.
3. Ensure the drain pipe has flex by installing clear tube or similar to prevent drain breakage or cracking.

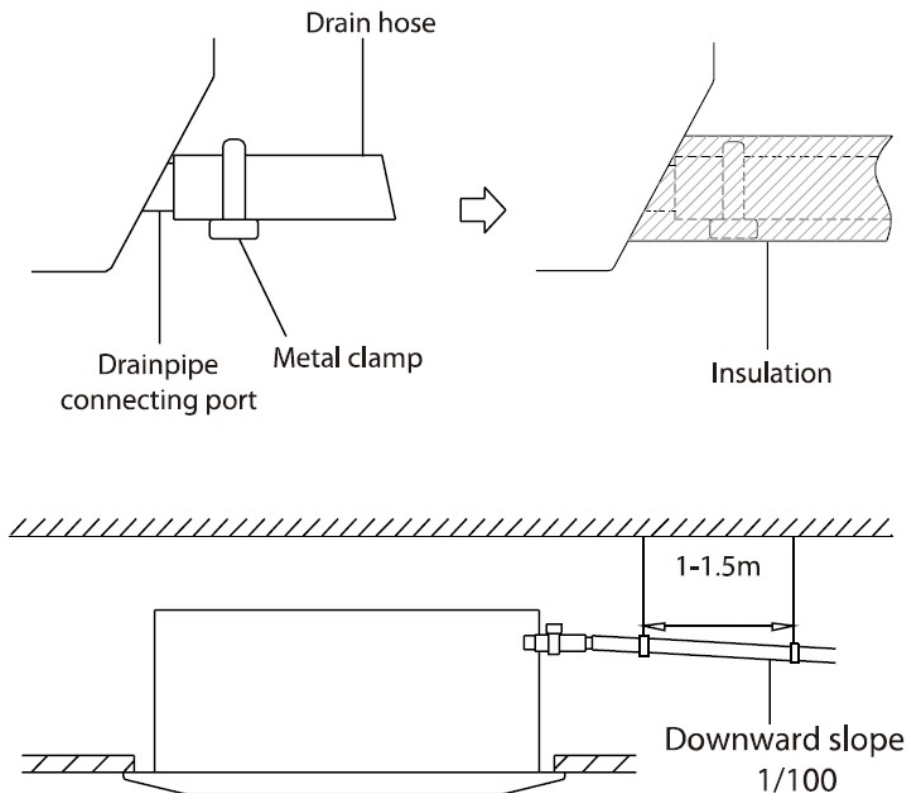

NOTE ON DRAIN PIPE INSTALLATION

- When using an extended drainpipe, tighten the indoor connection with an additional protection tube to prevent it from pulling loose.
- The drainpipe should slope downward at a gradient of at least 1/100 to prevent water from flowing back into the air conditioner.
- To prevent the pipe from sagging, space hanging wires every 1-1.5m.
- If the outlet of the drainpipe is higher than the body's pump joint, provide a lift pipe for the exhaust outlet of the indoor unit. The lift pipe must be installed no higher than 750mm and the distance between the unit and the lift pipe must be less than 300mm.
- Incorrect installation could cause water to flow back into the unit and flood.
- To prevent air bubbles, keep the drain hose level or slightly tilted (<75mm).

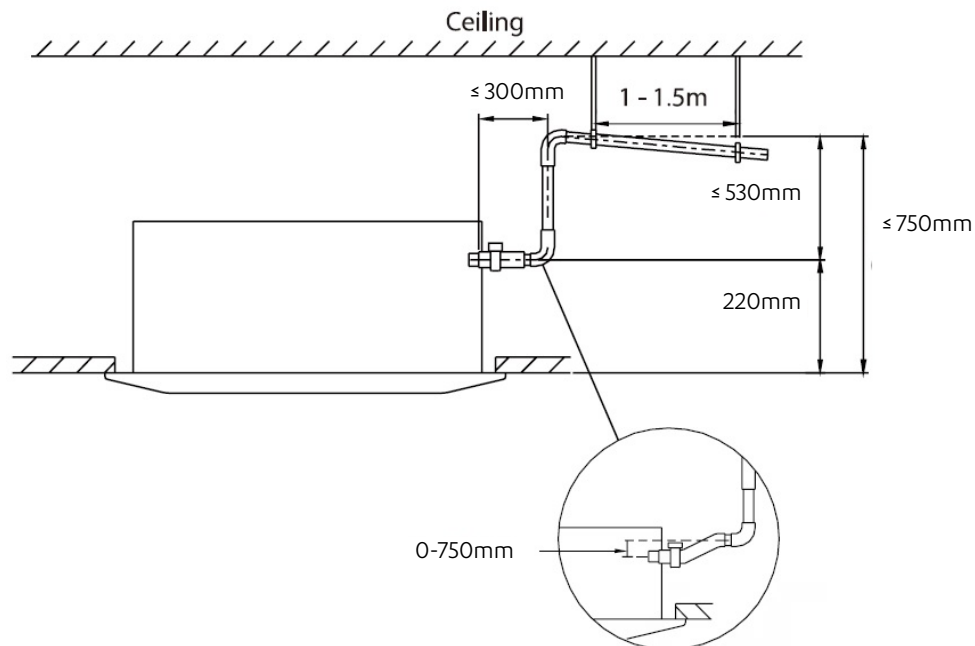

Fig. 5.3

NOTE

When connecting multiple drainpipes, install the pipes (as shown below) from pulling loose.

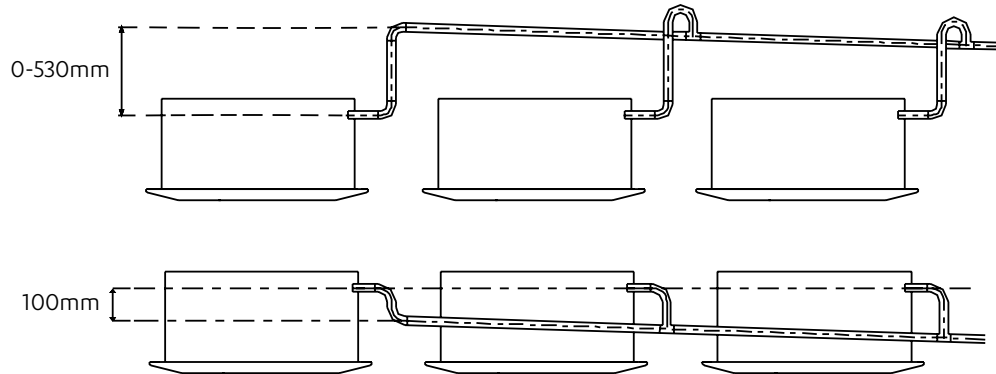
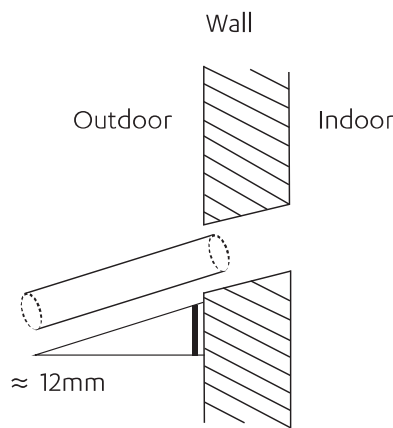

Fig. 5.4

- Using a 65-mm core drill, drill a hole in the wall. Make sure that the hole is drilled at a slight downward angle, so that the outdoor end of the hole is lower than the indoor end by about 12mm. This will ensure proper water drainage (See below). Place the protective wall cuff in the hole. This protects the edges of the hole and will help seal it when you finish the installation process.



NOTE

When drilling the wall hole, make sure to avoid wires, plumbing, and other sensitive components.

- Pass the drain hose through the wall hole. Make sure the water drains to a safe location where it will not cause water damage or a slipping hazard.

NOTE

The drainpipe outlet should be at least 50mm above the ground. If it touches the ground, the unit may become blocked and malfunction. If you discharge the water directly into a sewer, make sure that the drain has a U or S pipe to catch odour that might otherwise come back into the house.

12. Outdoor Unit Installation

Install the unit by following local codes and regulations, there may be differ slightly between different regions.

12.01. Outdoor Unit Clearance

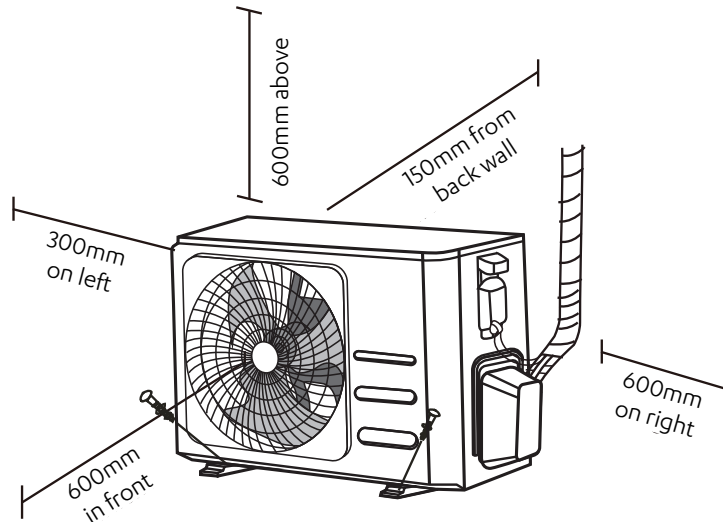

12.02. Outdoor Unit Installation Instructions

Step 1. Select Installation Location

Before installing the outdoor unit, you must choose an appropriate location. The following are standards that will help you choose an appropriate location for the unit.

Proper installation locations meet the following standards:

1. Meets all spatial requirements shown in Installation Space Requirements above.
2. Good air circulation and ventilation
3. Firm and solid: the location can support the unit and will not vibrate
4. Noise from the unit will not disturb others
5. Protected from prolonged periods of direct sunlight or rain
6. Where snowfall is anticipated, take appropriate measures to prevent ice buildup and coil damage.

DO NOT install unit in the following locations:

1. Near an obstacle that will block air inlets and outlets
2. Near a public street, crowded areas, or where noise from the unit will disturb others
3. Near animals or plants that will be harmed by hot air discharge
4. Near any source of combustible gas
5. In a location that is exposed to large amounts of dust
6. In a location exposed to a excessive amounts of salty air

Special Consideration For Extreme Weather

If the unit is exposed to heavy wind:

Install unit so that air outlet fan is at a 90° angle to the direction of the wind. If needed, build a barrier in front of the unit to protect it from extremely heavy winds (refer to Outdoor Unit Clearance for required distance from unit).

See Figures below.

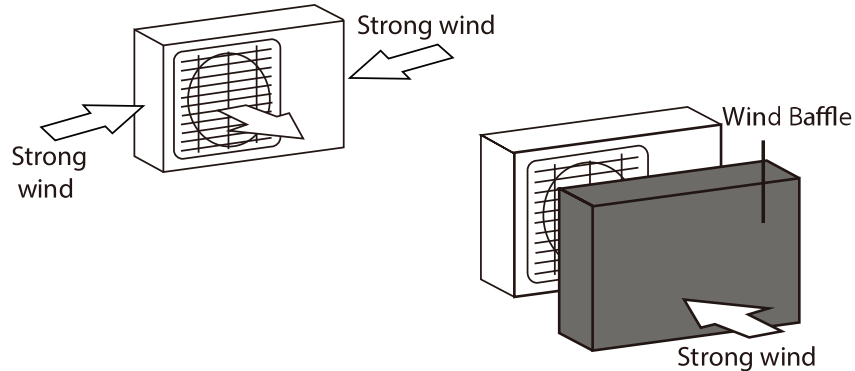

If the unit is frequently exposed to heavy rain or snow:

Build a shelter above the unit to protect it from the rain or snow. Be careful not to obstruct air flow around the unit.

If the unit is frequently exposed to salty air (seaside):

Use outdoor unit that is specially designed to resist corrosion.

Step 2. Install Drain Joint

Before bolting the outdoor unit in place, you must install the drain joint at the bottom of the unit. Note that there are two different types of drain joints depending on the type of outdoor unit.

The drain joint comes with a rubber seal, follow steps below for proper fitting.

1. Fit the rubber seal on the end of the drain joint that will connect to the outdoor unit.
2. Insert the drain joint into the hole in the base pan of the unit.
3. Rotate the drain joint 90° until it clicks in place facing the front of the unit.
4. Connect a drain hose extension (not included) to the drain joint to redirect water from the unit during heating mode.

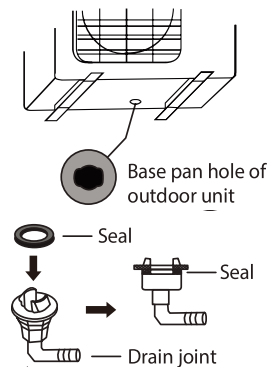

⚠ CAUTION

In Cold Climates

Make sure that the drain hose is as vertical as possible to ensure swift water drainage. If water drains too slowly, it can freeze in the hose and flood the unit.

Step 3. Anchor Outdoor Unit

The outdoor unit can be anchored to the ground or to a wall-mounted bracket with bolt(M10). Prepare the installation base of the unit according to the dimensions below.

12.03. Unit Mounting Dimensions

The following is a list of different outdoor unit sizes and the distance between their mounting feet. Prepare the installation base of the unit according to the dimensions below.

Split Type Outdoor Unit

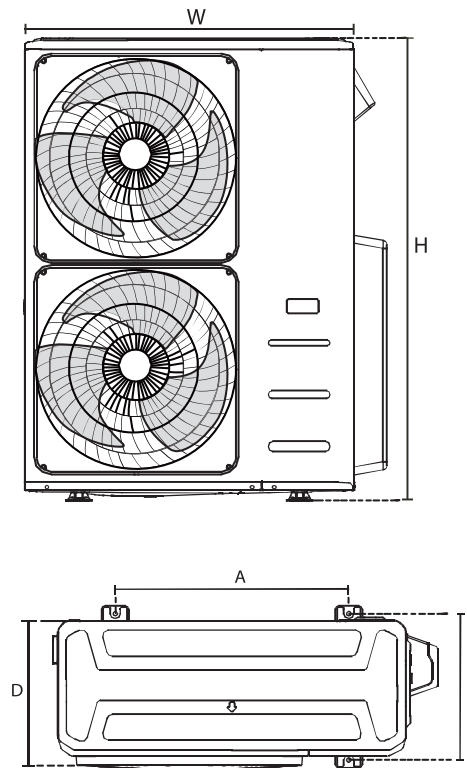

Outdoor Unit Specifications Table

Model Number	Outdoor Unit Dimensions H X W X D	Mounting Dimensions (Centre to Centre)	
		A (mm)	B (mm)
CRC-100CS	952x415x1333	634	404
URC-125CS			
URC-140CS			

Drilling Hole In Wall

You must drill a hole in the wall for the refrigerant piping, and the signal cable that will connect the indoor and outdoor units.

1. Determine the location of the wall hole based on the location of the outdoor unit.
2. Using a 65mm (2.5 in) core drill, drill a hole in the wall.

NOTE

When drilling the wall hole, make sure to avoid wires, plumbing, and other sensitive components.

3. Place a protective wall cuff in the hole. This protects the edges of the hole and helps seal it when you finish the installation process.

13. Refrigerant Piping Connection

Outdoor Model	CRC-100CS	URC-125CS	URC-140CS
Minimum Field Pipe Length (m)	3	3	3
Maximum length for all rooms (m)	75	75	75
Maximum Vertical (m)	30	30	30
Liquid Pipe mm (inch)	9.52	9.52	9.52
Gas Pipe mm (inch)	15.88	15.88	15.88

NOTE

Ensure that the length of the refrigerant pipe, the number of bends, and the drop height between the indoor and outdoor units meets the requirements shown in above table.

Refrigerant Piping Connection Instructions:

1. Run the refrigerant pipework ensuring it is not touching any beams or structure that may cause excessive noise to be transmitted through the building.
2. Ensure both pipes are insulated.
3. Cut the connecting pipes according to required length.
4. Remove burrs in the pipe. Burrs can affect the air-tight seal of refrigerant piping connections.
5. Place flare nuts on both ends of pipe. Flare each end of connecting pipes.

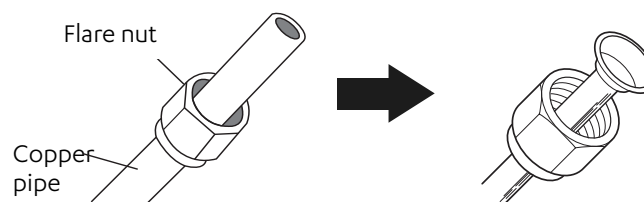

6. It is recommended that the refrigeration pipework is run externally to limit gas noise inside the occupancy.

7. Connect the pipe to indoor and outdoor unit. Apply a thin coat of refrigeration oil to the flared end of the pipe. Tighten the flare nuts using a spanner and torque wrench.

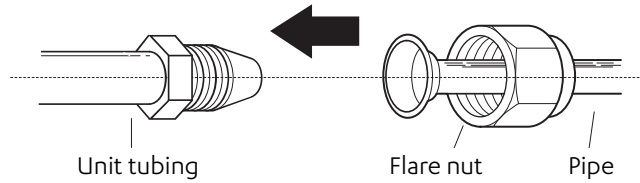

Pipe Flare Dimension and Tightening Torque Guide				
Pipe Size	Tightening Torque	Flare Dimension (A)		Flare Shape
		Min (mm)	Max (mm)	
Ø 9.52	32 - 39 Nm	13.2	13.5	<p>The diagram shows a cross-section of a pipe flare. The top edge is labeled with a 90° ± 4 angle. The inner bevel is labeled with a 45° ± 2 angle. The width of the flare is labeled 'A'. The bottom edge of the flare has a radius labeled R0.4~0.8.</p>
Ø 15.88	57 - 71 Nm	19.2	19.7	

CAUTION

- Ensure to wrap insulation around the piping. Direct contact with the bare piping may result in burns or frostbite.
- Make sure the pipe is properly connected. Over tightening may damage the bell mouth and under tightening may lead to leakage.

Instructions for Connecting Piping to Outdoor Unit

NOTE

Installation of this unit should be in accordance with Electrical Safety Standard, AS/NZS 60335.2.40. If the smallest room to be conditioned is less than the required minimum room area (A_{min}), additional safety provision maybe needed such as leak detector sensor and/or ventilation to comply, for more details refer to Annex GG and Annex HH of the above standard.

Refer to R-32 Safety Manual for minimum required area of installation.

1. Unscrew the valve cover on the side of the outdoor unit.

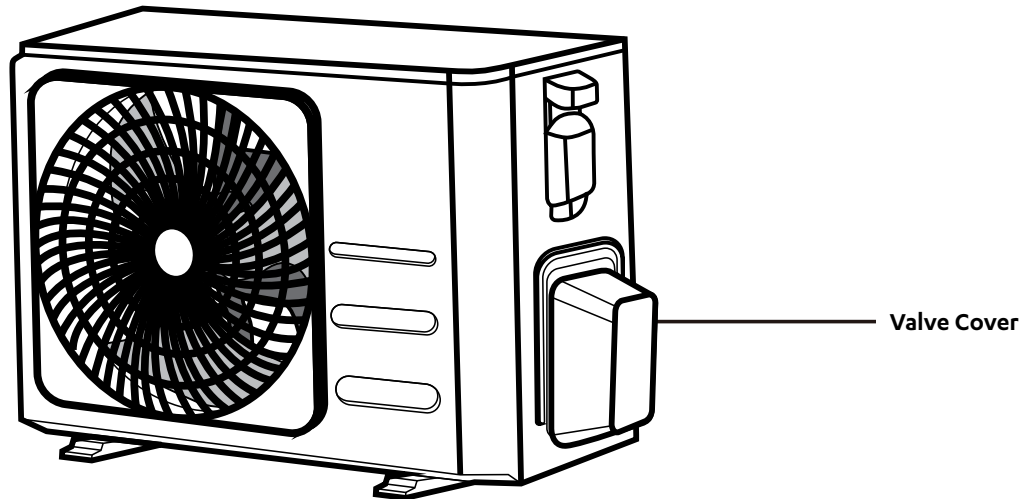

2. Remove protective caps from ends of valves.
3. Align flared pipe end with each valve, and tighten the flare nut as tightly as possible by hand.
4. Using a spanner, grip the body of the valve. Do not grip the nut that seals the service valve.

NOTE

USE SPANNER TO GRIP MAIN BODY OF VALVE. Torque from tightening the flare nut can snap off other parts of valve.

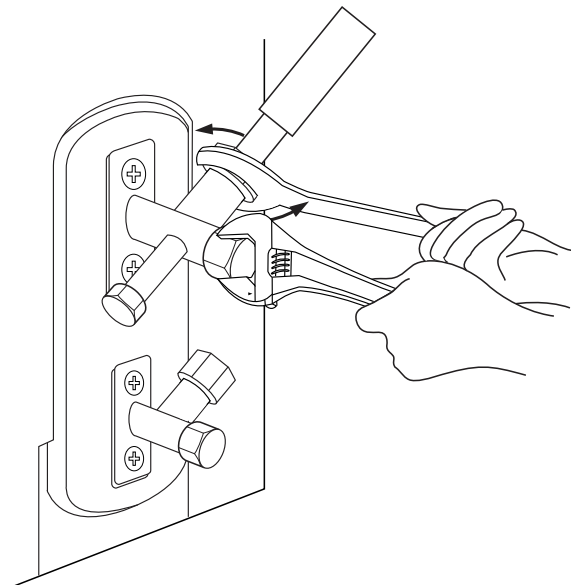

5. While firmly gripping the body of the valve, use a torque wrench to tighten the flare nut according to the correct torque values.
6. Loosen the flaring nut slightly, then tighten again.
7. Repeat Steps 4 to 6 for the remaining pipe.

8. Mount the Valve cover back.

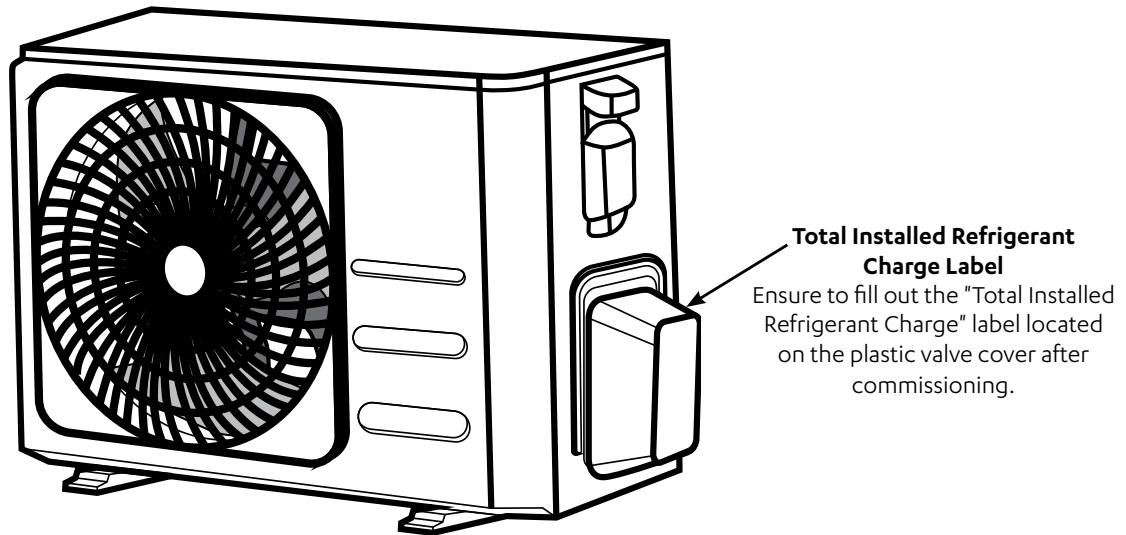

CAUTION

If the indoor unit is installed at a higher position than the outdoor unit, there is a chance that oil may flow into the compressor. This may cause liquid compression or deterioration of oil return. Use oil traps in the gas piping to prevent this. An oil trap should be installed every 10m in the vertical suction line riser.

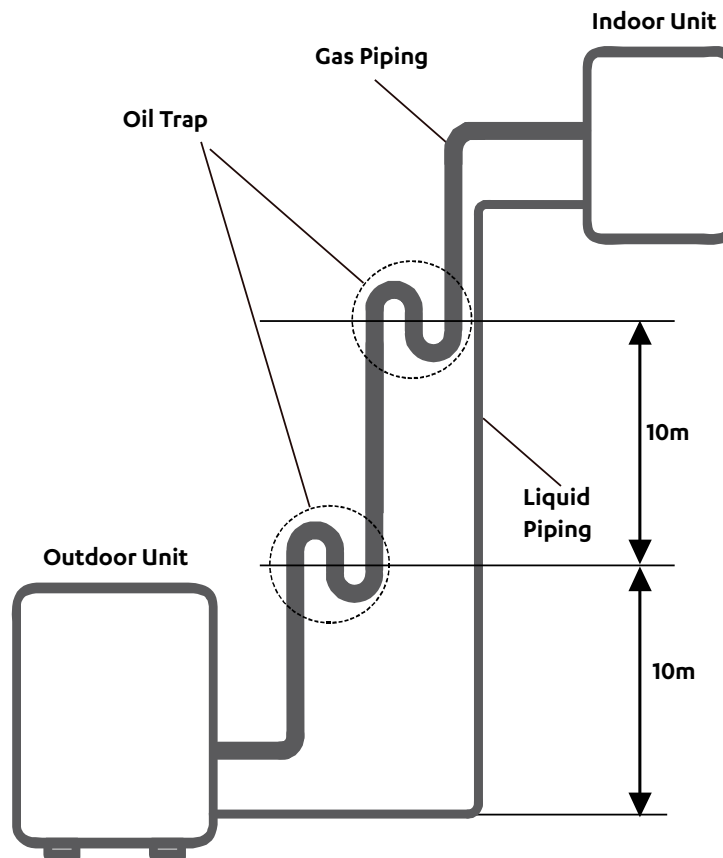

CAUTION

If the outdoor unit is installed at a higher position than the indoor unit, it is recommended that the vertical suction risers not be upsized. Proper oil return to the compressor should be maintained with suction gas velocity. If velocities drop below 7.62 m/s, oil return will be decreased. An oil trap should be installed every 6m of vertical suction line riser.

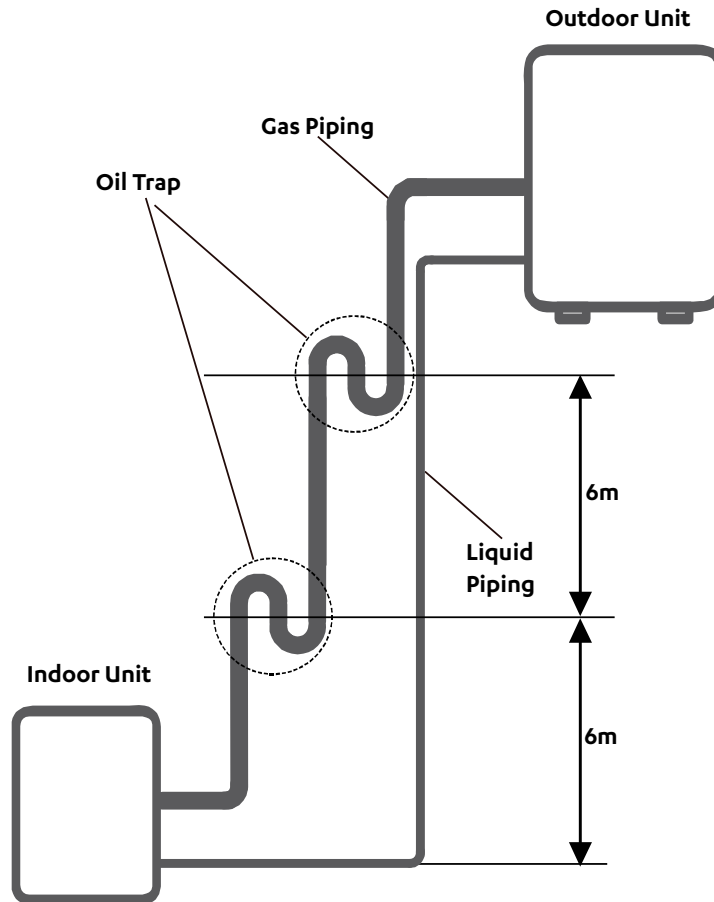

14. Wiring

Safety Precautions



WARNING

- Be sure to disconnect the power supply before working on the unit.
- All electrical wiring must be done according to local and national regulations.
- Electrical wiring must be done by a qualified technician. Improper connections may cause electrical malfunction, injury and fire.
- Connect the power cable to the terminals and fasten it with the clamp.
- Make sure that all wiring is done correctly and the control board cover is properly installed. Failure to do so can cause overheating at the connection points, fire, and electrical shock.



CAUTION

- Connect the outdoor wires before connecting the indoor wires.
- Make sure you earth the unit. Improper earthing may cause electrical shock.
- DO NOT connect the unit with the power source until all wiring and piping is completed.
- Make sure that you do not cross your electrical wiring with your signal wiring, as this can cause distortion and interference.

Follow these instructions to prevent distortion when the compressor starts:

- The unit must be connected to its individual sub-circuit. Ensure sub-circuit mains are of recommended size to ensure minimal voltage drop at supply terminals.
- No other equipment should be connected to the same sub-circuit as the A/C unit.
- The unit's power information can be found on the rating sticker on the product.

TAKE NOTE OF FUSE SPECIFICATIONS

The air conditioners circuit board (PCB) is designed with a fuse to provide over current protection. The specifications of the fuse is printed on the circuit board, T3.15A/250VAC.

For the units with R-32 refrigerant , only the blast-proof ceramic fuse can be used.

Indoor Unit Wiring

1. Prepare the cable for connection
 - a. Using wire strippers, strip the outer insulation from both ends of signal cable.
 - b. Strip the insulation from the ends of the internal wires.
 - c. Using a wire crimper, crimp fork-lugs on the ends of the wires.
2. Remove the cover of the electric control box on your indoor unit.
3. Thread the power cable and the signal cable through the wire outlet.

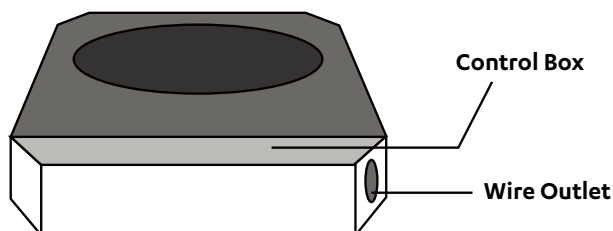

4. Connect the fork-lugs to the terminals. Match the wire colors/labels with the labels on the terminal block, and firmly screw the lug of each wire to its corresponding terminal. Refer to the Serial Number and Wiring Diagram located on the cover of the electric control box.

5. Clamp down cable with the designated cable clamp to secure it in place. The cable should not be loose, and should not pull on the lugs.
6. Reinstall the electric box cover.

CAUTION

- While connecting the wires, please strictly follow the wiring diagram.
- The refrigerant circuit can become very hot. Keep the interconnection cable away from the copper tube.

Electrical Connection

- | | |
|--|--|
| <p>—— ① MAINS WIRING (220-240VAC)
(Single Phase + Neutral) 50Hz</p> <p>—— ② CONTROL WIRING (220-240VAC)
(Single Phase + Neutral) 50Hz 2 Core + Earth</p> | <p>- - - - ③ EXTRA LOW VOLTAGE DATA CONTROL WIRING
2 core shielded data cable 14/0.20 (0.44mm²) maximum
65 metres</p> <p>..... ④ EXTRA LOW VOLTAGE DATA CONTROL WIRING
4 core shielded data cable (0.75mm²) maximum 20 metres
or (1.5mm²) maximum 50 metres</p> |
|--|--|

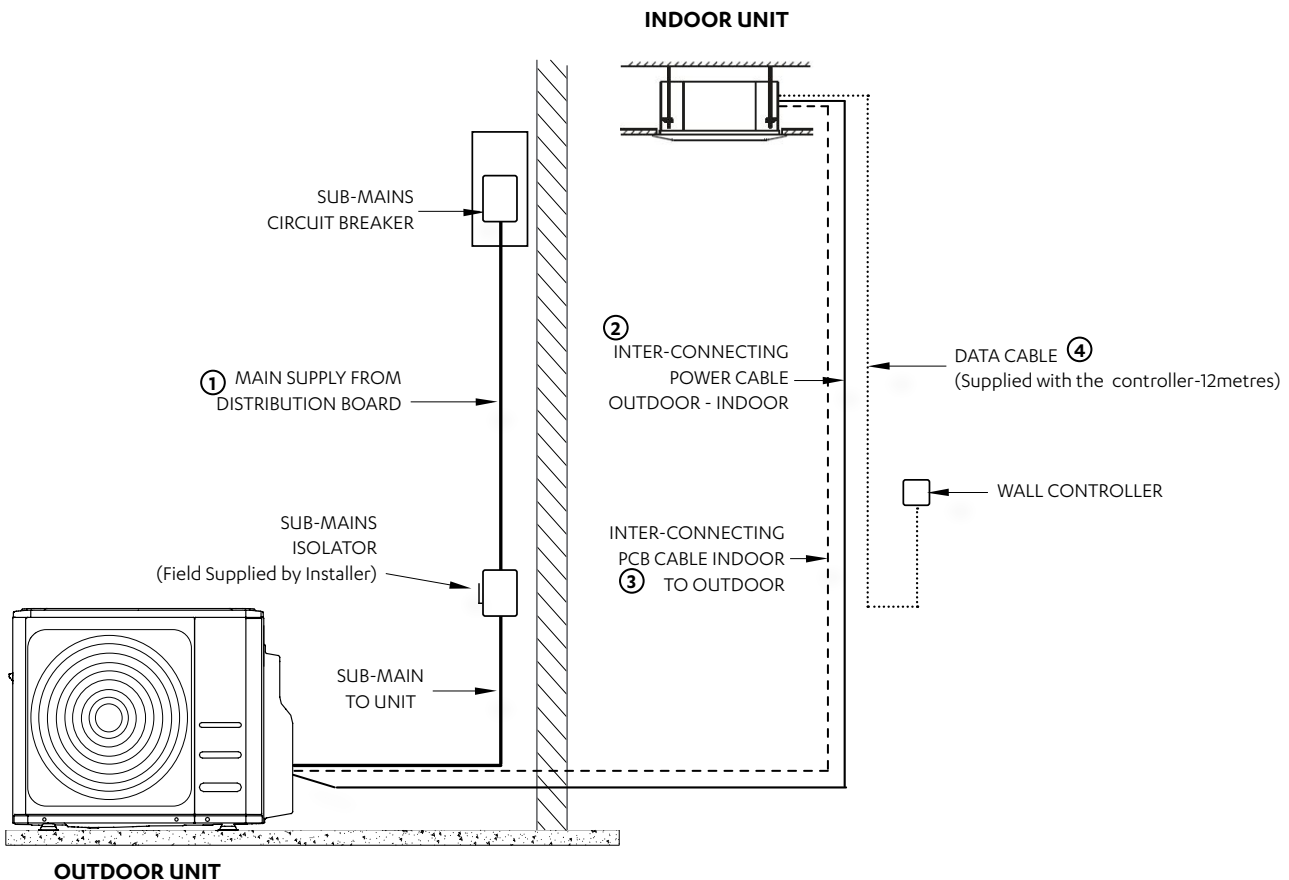

Connecting Diagram

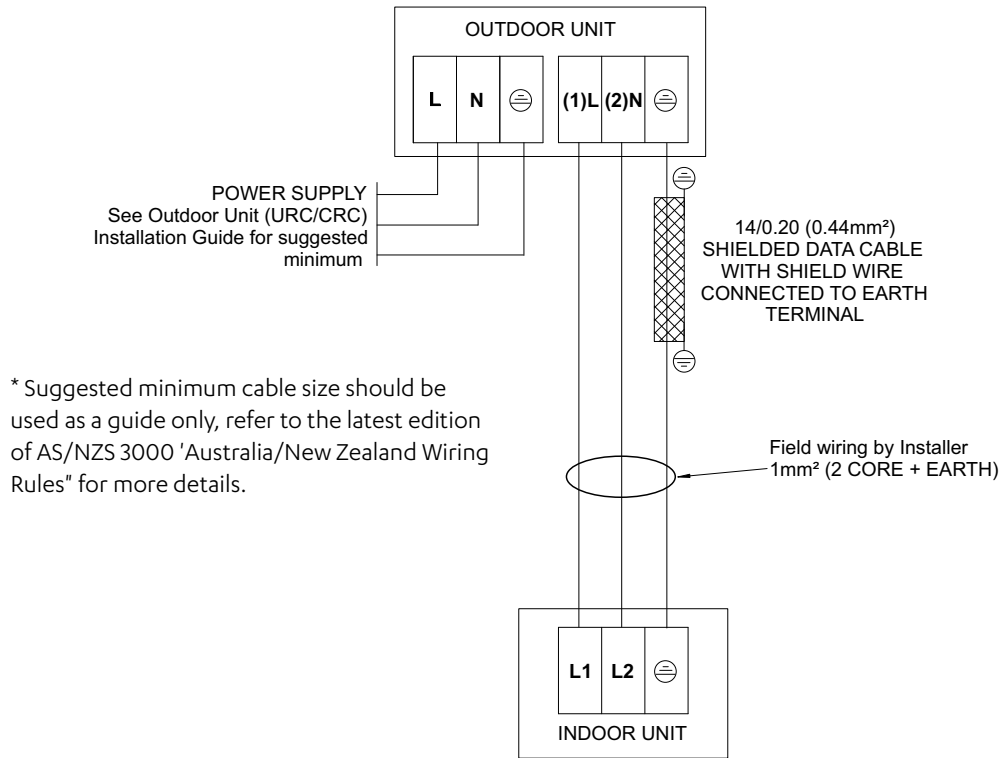

15. Electrical Wiring

NOTE

- Electrical wiring must be done by a qualified technician. Improper connections may cause electrical malfunction, injury and fire.
- Air conditioning equipment should be grounded according to the local electrical regulations.
- Current leakage protection switch should be installed.
- Do not connect the power wire to the terminal of signal wire.
- When power wire is parallel with signal wire, put wires to their own wire tube and remain at least 300mm gap.
- According to table in indoor part named "the specification of the power" to choose the wiring, make sure the selected wiring not small than the date showing in the table.
- Select different colours for different wire according to relevant regulations.
- Do not use metal wire tube at the place with acid or alkali corrosion, adopt plastic wire tube to replace it.
- There must be not wire connect joint in the wire tube If joint is a must, set a connection box at the place.
- The wiring with different voltage should not be in one wire tube.
- Ensure that the colour of the wires of outdoor and the terminal No. are same as those of indoor unit respectively.

15.01. Minimum Cross-Sectional Area able of Power and Signal Cables

Rated Current of Appliance (A)	Nominal Cross-Sectional Area(mm2)
≤ 6	0.75
6 - 10	1
10 - 16	1.5
16 - 25	2.5
25 - 32	4
32 - 45	6

15.02. Electrical wiring installation

NOTE

Please prepare spanner and fat-blade screwdriver before your installation work.

Step 1. Remove two fixing screws, then remove the front panel.

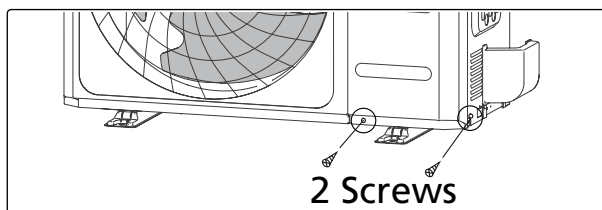

Step 2. Use spanner and fat-blade screwdriver to knock down two metal seals, then pick the metal fakes out.

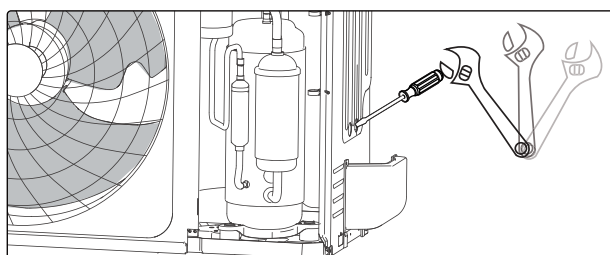

Step 3. Connect the power cable and indoor & outdoor connection cable. Clamp down the cable with the cable clamp.

Step 4. The wire groups shall be bound with cable ties and fixed on the right side plate after they are connected. The strong electric wire group and weak electric wire group shall be led out separately through the two knock down holes on the bottom of the right side plate and fastened with a locking connector as shown in the figure below.

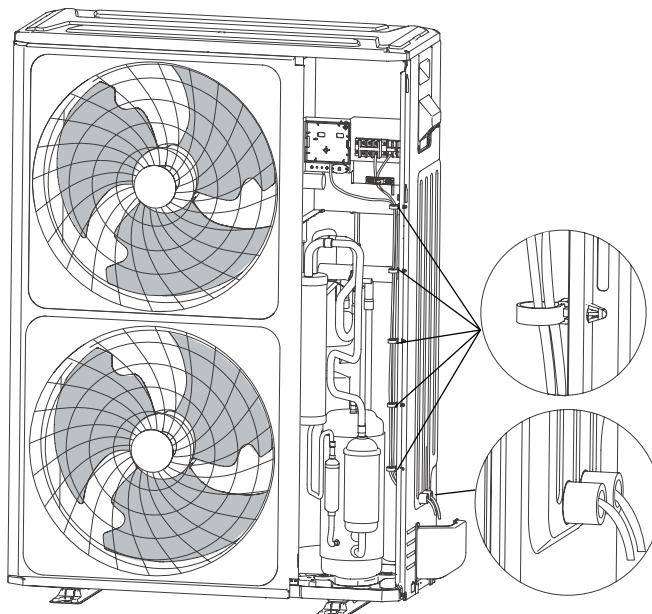

16. Wiring Diagram

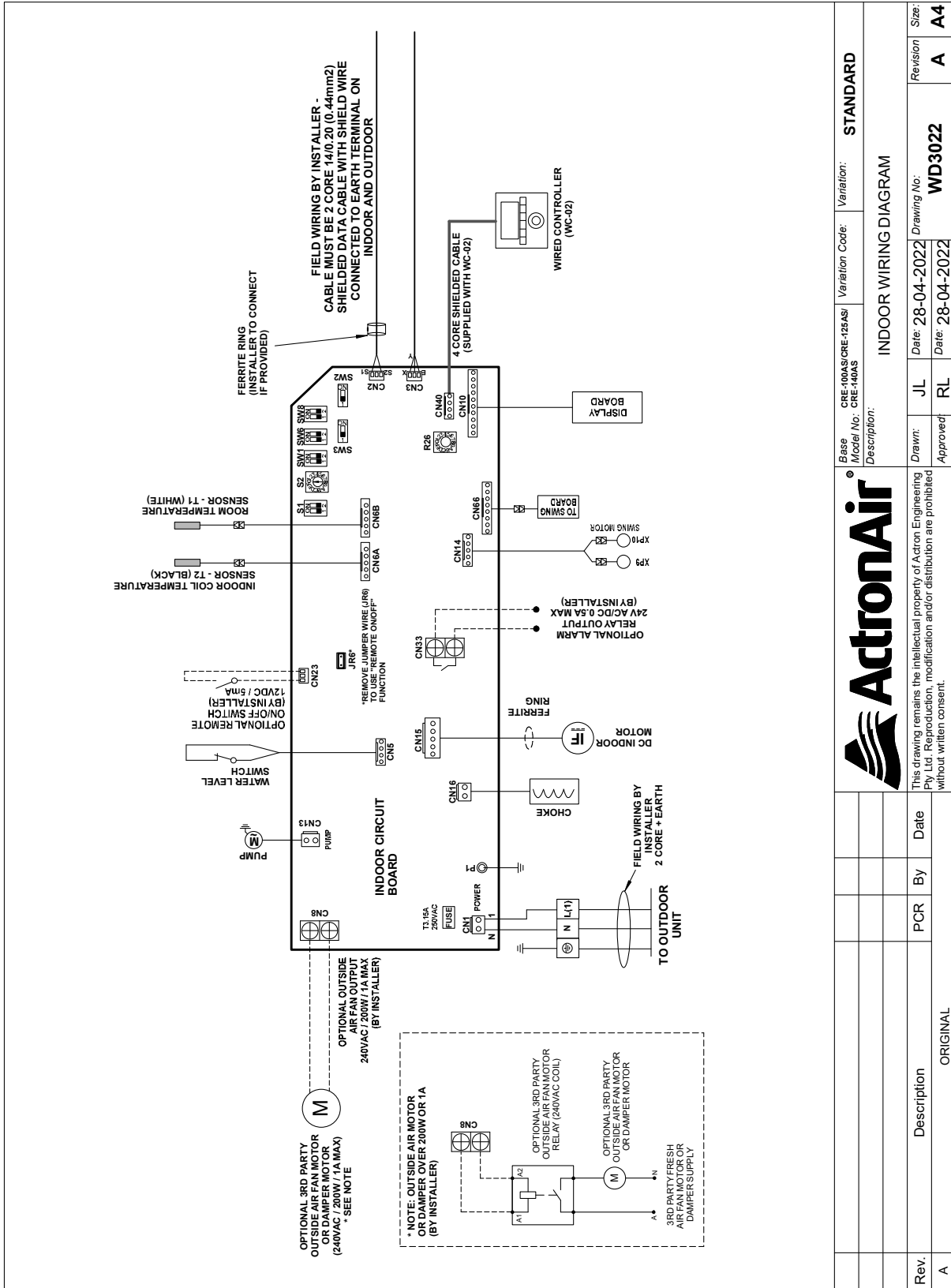

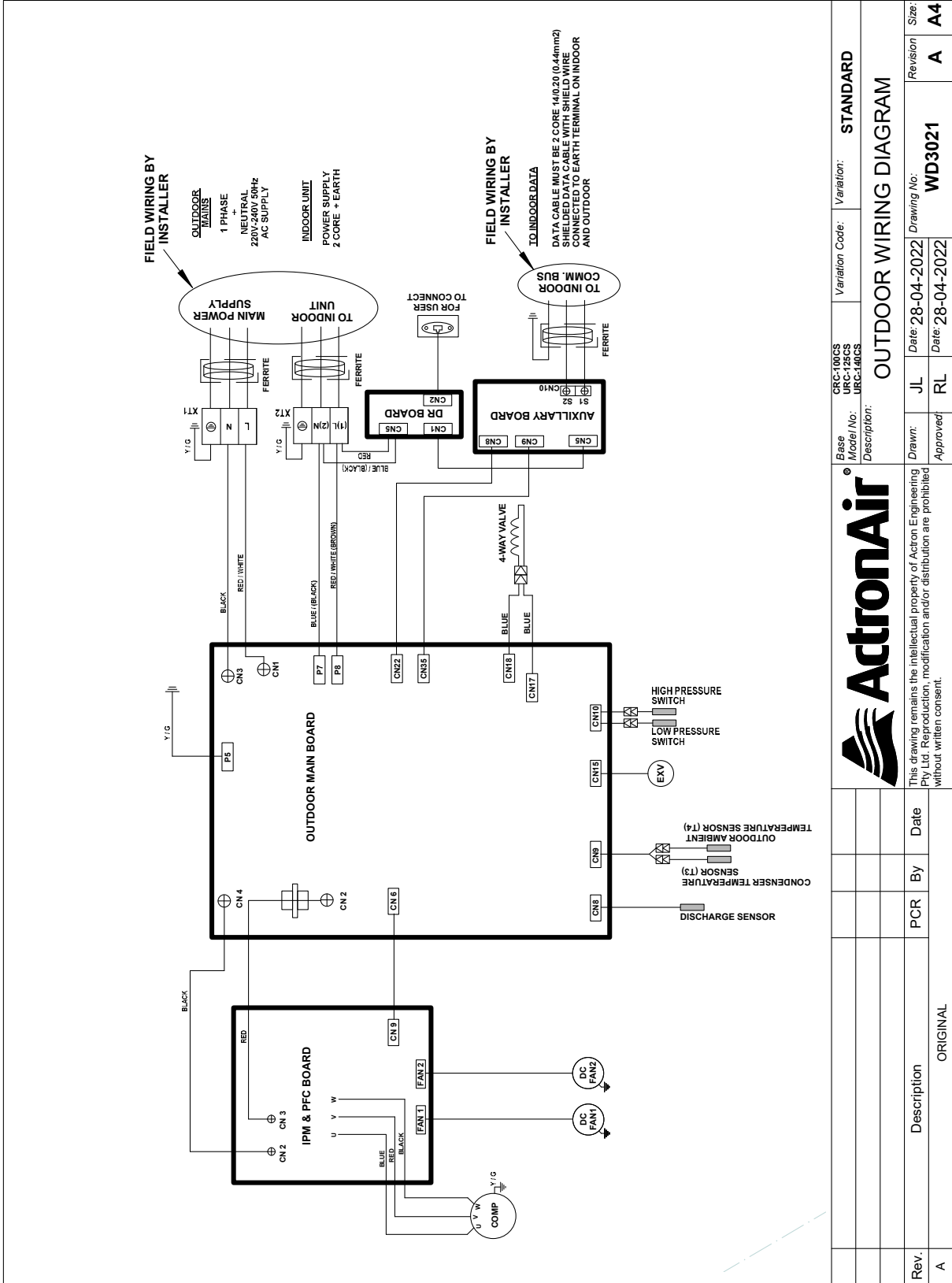

		Base Model No: CRC-100CS URC-125CS URC-140CS	Variation Code: STANDARD
OUTDOOR WIRING DIAGRAM			
Description: This drawing remains the intellectual property of Actron Engineering Pty Ltd. Reproduction, modification and/or distribution are prohibited without written consent.	Drawing No: WD3021	Date: 28-04-2022	Revision: A
Approved: RL	Date: 28-04-2022	Drawing No: WD3021	Size: A4
Description: ORIGINAL	By: PCR	Date: [Blank]	Rev. No: A

17. Air Evacuation

CAUTION

- Refrigerant charging must be performed after wiring, vacuuming and the leak test.
- **DO NOT** exceed the maximum allowable quantity of refrigerant or overcharge the system. Doing so can damage or impact the unit's function.
- Charging with unsuitable substances may cause explosions or accidents. Ensure that the appropriate refrigerant is used.
- Refrigerant containers must be opened slowly. Always use protective gear when charging the system.
- **DO NOT** mix refrigerant types.
- Some systems require additional charging depending on pipe lengths. The standard pipe length is 15m.

Preparations and Precautions

Air and foreign matter in the refrigerant circuit can cause abnormal rises in pressure, which can damage the air conditioner, reduce its efficiency, and cause injury. Use a vacuum pump and manifold gauge to evacuate the refrigerant circuit, removing any non-condensable gas and moisture from the system.

Evacuation should be performed upon initial installation and when unit is relocated.

Before Performing Evacuation

1. Check to make sure the connective pipes between the indoor and outdoor units are connected properly.
2. Check to make sure all wiring is connected

Evacuation Instructions

Before using a manifold gauge and a vacuum pump, read their operation manuals to make sure you know how to use them properly.

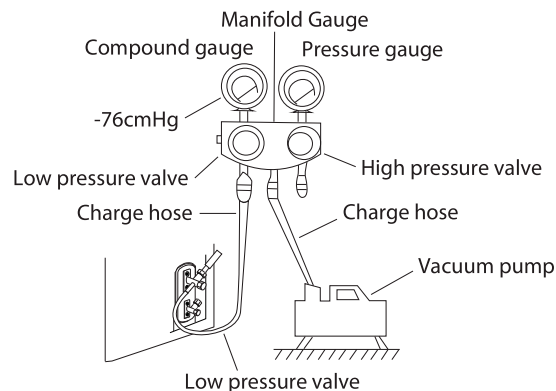

1. Fit service gauges to the ball valves (liquid line service valve and suction line service valve).
2. Evacuate the system to 1000 microns.
3. Check vacuum with vacu stat. Break the vacuum with dry Nitrogen to 100kPa
4. Release Nitrogen pressure. Evacuate to 500 microns.
5. Check vacuum with vacu stat. Break the vacuum with dry Nitrogen to 100kPa
6. Release Nitrogen pressure. Evacuate to 500 microns.
7. Check vacuum with vacu stat. Let the unit stand for 1 hour and with the vacuum not rising above 500 microns

NOTE

If there is no change in system pressure, unscrew the cap from the packed valve (high pressure valve). If there is a change in system pressure, there may be a gas leak.

- Insert hexagonal wrench into the post valve (liquid line valve) and open the valve by turning the wrench 1/4 counterclockwise. Listen for gas to exit the system, then close the valve after 5 seconds.

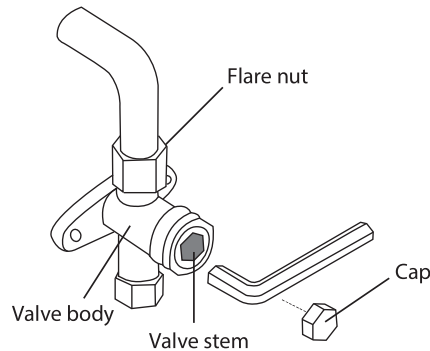

- Watch the Pressure Gauge for one minute to make sure that there is no change in pressure. It should read slightly higher than the atmospheric pressure.
- Remove the charge hose from the service port.
- Using hexagonal wrench, fully open both the high pressure and low pressure valves.

CAUTION

OPEN VALVE STEMS GENTLY

When opening valve stems, turn the hexagonal wrench until it hits against the stopper. **DO NOT** try to force the valve to open further.

- Tighten valve caps on both valves (service port, high pressure, low pressure) by hand. You may tighten it further using a torque wrench if needed.
- If the outdoor unit uses all vacuum valves, and the vacuum position is at the main valve, the system is not connected with the indoor unit. The valve must be tightened with a screw nut. Check for gas leaks before operation to prevent leakage.

17.01. Refrigerant Charge Details

Model	CRC-100CS	URC-125CS	URC-140CS
Refrigerant Type	R-32	R-32	R-32
Refrigerant Charge (grams)	3600	3600	3600
Pre-charged Length (metres)	5	5	5
Additional Refrigerant per metre (grams/metres)	24	24	24
Liquid Pipe	9.52	9.52	9.52
Gas Pipe	15.88	15.88	15.88

18. Electrical and Gas Leak Checks

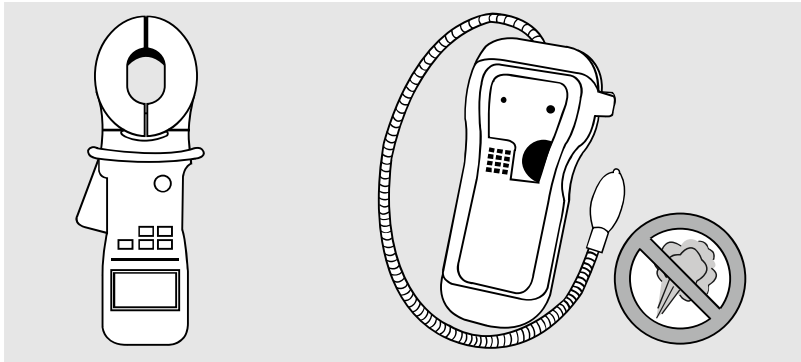

18.01. Gas Leak Checks

Proper pressure test with dry nitrogen should be performed, prior to air evacuation. Perform leak detection test with electronic leak detector after letting refrigerant into pipework

Leak Test

1. Run interconnecting pipe work from condenser to evaporator.
2. Connect the liquid and suction pipe to the indoor and outdoor unit flare connections (please see refrigerant piping connection instruction).
3. Fit service gauge to the service port on the outdoor unit.
4. Fit a nitrogen to the service gauge.
5. Pressure test the system between 2500kPa and the system's maximum kPa as determined in **AS/NZS 5149.2:2016, Clause 5.2.2.1 Maximum Allowable Pressure**. Ensure pressure is held for no less than 1 hour.

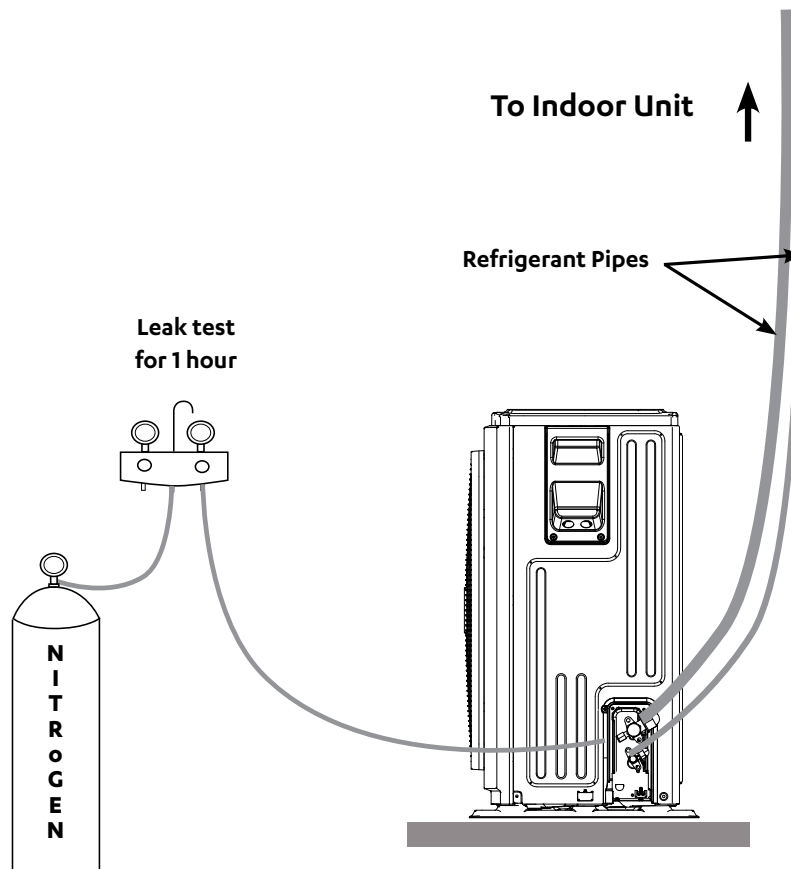

NOTE

After confirming that all pipe connection points **DO NOT** leak, replace the valve cover on the outside unit.

CAUTION

- Use a vacuum pump and a vac stat reading lower than 500 microns and an air discharge capacity above 40L/min.
- The outdoor unit does not need vacuuming **DO NOT** open the outdoor unit's gas and liquid stop valves.
- Ensure that your vac stat reads 500 micron or below after 2 hours. If after three hours of operation and the vac stat reading is still above 500 microns, check re-pressurise system and check for gas leak. If there is no leakage, perform another evacuation for 1 to 2 hours or until the vac stat reads 500 microns or below.
- **DO NOT** use refrigerant gas during a leak test of a system.
- Ensure all gauge manifold, leak detector and vacuum pump are compatible and safe to use with R-32 refrigerant.

18.02. Electrical Safety Checks

After installation, confirm that all electrical wiring is installed in accordance with local and national regulations.

WARNING

All wiring must comply with local and national electrical codes, and must be installed by a licensed electrician.

Electrical Safety Check

Perform the electric safe check after completing installation.

1. Insulated resistance
The insulated resistance must be more than 2MΩ.
2. Grounding work
After finishing grounding work, measure the grounding resistance by visual detection and grounding resistance tester. Make sure the grounding resistance is less than 4Ω.
3. Electrical leakage check (performing during test running)
During test operation after finishing installation, the service technician can use the multimeter to perform the electrical leakage check. Turn off the unit immediately, rectify before continuing.

19. Installation of the Panel

CAUTION

DO NOT place the panel face down on the floor, against a wall, or on uneven surfaces.

1. Remove the front Grille.
 - a. Push both of the tabs towards the middle simultaneously to unlock the hook on the grille.

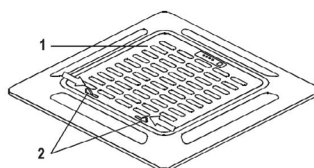

- 1 Intake grille
- 2 Grille hook

- b. Hold the grille at a 45° angle, lift it up slightly and detach it from the main body.

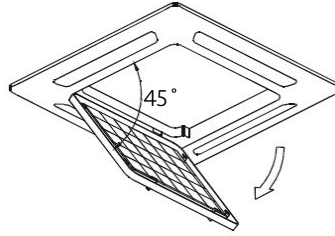

2. Mounting the frame.

- a. Align the indicate "Δ" on the unit. Attach the decoration panel to the unit with the supplied screws as shown in figure below.

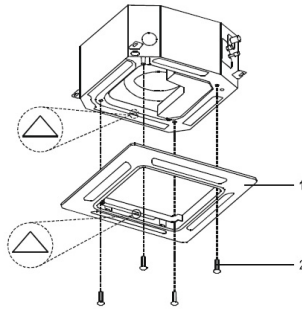

- 1 Decoration panel
- 2 Screws (M5) (supplied with the panel)

- b. After installing the decoration panel, ensure that there is no space between the unit body and decoration panel. Otherwise air may leak through the gap and cause dewdrop.

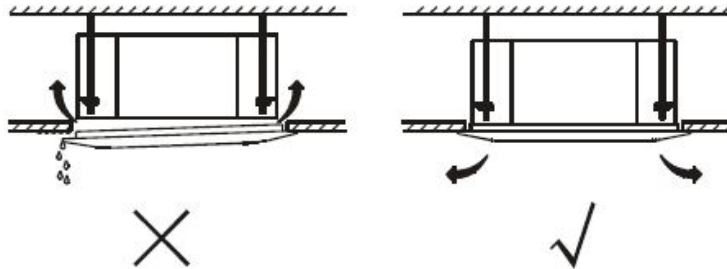

3. Mount the intake grille.

Ensure that the buckles at the back of the grille be properly seated in the groove of the panel

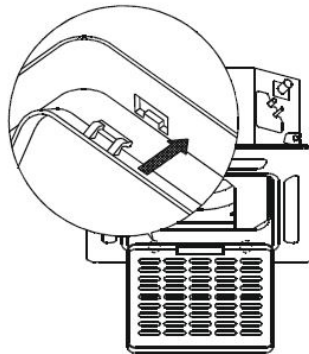

4. Connect the 2 wires of the fascia panel to the main board of the unit.

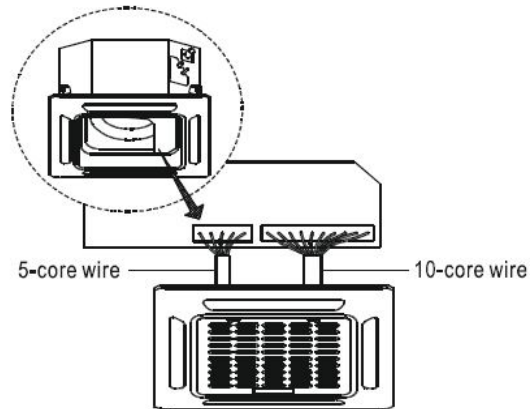

5. Fasten the control box lid with 2 screws.

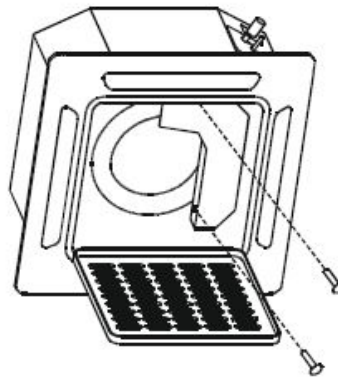

6. Close the intake grille, and close the 2 grille hooks.

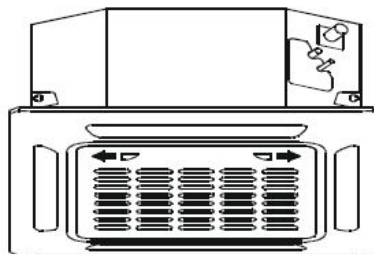

20. Test Run

Before Commissioning

Only perform test run after you have completed the following steps:

- **Electrical Safety Checks** – Confirm that the unit's electrical system is safe and operating properly.
- **Gas Leak Checks** – Check all flare nut connections and confirm that the system is not leaking

A test run must be performed after the entire system has been completely installed. Confirm the following points before performing the test:

- a. The indoor and outdoor units are properly installed.
- b. Piping and wiring are properly connected.
- c. Ensure that there are no obstacles near the inlet and outlet of the unit that might cause poor performance or product malfunction.
- d. The refrigeration system does not leak.
- e. The drainage system is unimpeded and draining to a safe location.
- f. The heating insulation is properly installed.
- g. The earth wires are properly connected.
- h. The length of the piping and the added refrigerant stow capacity have been recorded.
- i. The supply voltage is the correct voltage for the air conditioner.

CAUTION

Failure to perform commissioning may result in unit damage, property damage or personal injury and may void warranty.

Test Run Instructions

1. Open both the liquid and gas stop valves.
2. Turn on the main power switch and allow the unit to warm up.
3. Set the air conditioner to **COOL** mode.
4. For the Indoor Unit
 - a. Ensure the remote control and its buttons work properly.
 - b. Ensure the louvres move properly and can be changed using the remote control.
 - c. Check to see if the room temperature is being registered correctly.
 - d. Ensure the indicators on the remote control and the display panel on the indoor unit work properly.
 - e. Ensure the manual buttons on the indoor unit works properly.
 - f. Check to see that the draining system is unimpeded and draining smoothly.
 - g. Ensure there is no vibration or abnormal noise during operation.
5. For the Outdoor Unit
 - a. Check to see if the refrigeration system is leaking.
 - b. Make sure there is no vibration or abnormal noise during operation.
 - c. Ensure the wind, noise, and water generated by the unit do not disturb your neighbours or pose a safety hazard.
 - d. Check the refrigeration pressures to ensure they operating correctly.
 - e. Check the voltage and current drawn from the unit is correct.
 - f. Ensure anti vibration rubbers have been fitted under the outdoor unit feet.

6. Fill out the "Total Installed Refrigerant Charge" label located on the plastic valve cover.

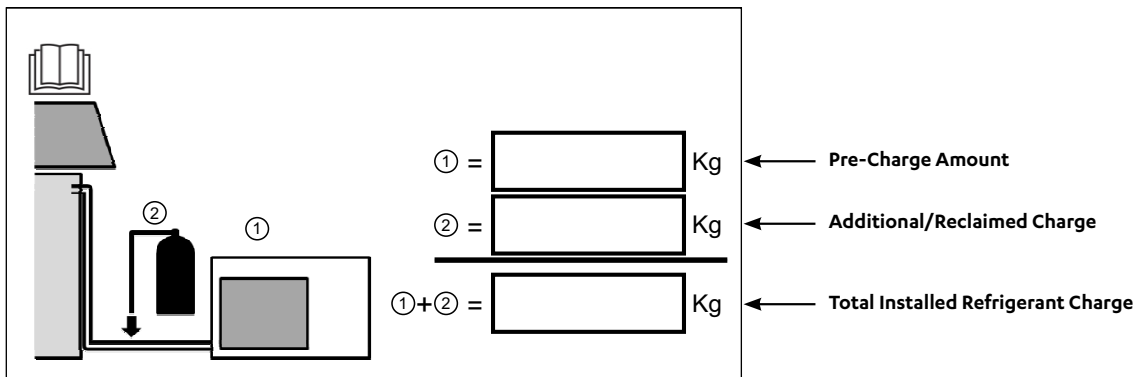

NOTE

The factory charge (or Pre-Charge Amount) is written on the Rating Label of the Outdoor unit. Where adjustment to charge is required to complete the refrigerating system, the installer should note the resulting "Additional/Reclaimed Charge" and "Total Installed Refrigerant Charge" on the label located in the outer part of the valve cover of the Outdoor unit and "Start Up and Commissioning Report" of R-32 Safety Manual. If no refrigerant adjustment was done, the Additional/Reclaimed Charge is "0"; Pre-Charge Amount and Total Installed Refrigerant Charge is equal to the factory charge.

Drainage Test

1. Ensure the drainpipe flows smoothly.
2. Remove the test cover. Add 2,000ml of water to the tank through the attached tube.
3. Turn on the main power switch and run the air conditioner in **COOL** mode.
4. Listen to the sound of the drain pump to see if it makes any unusual noises.
5. Check to see that the water is discharged. It may take up to one minute before the unit begins to drain depending on the drainpipe.
6. Make sure that there are no leaks in any of the piping.
7. Stop the air conditioner. Turn off the main power switch and reinstall the test cover.

NOTE

If the unit malfunctions or does not operate according to your expectations, please refer to the Troubleshooting section of the Owner's Manual before calling customer service.

21. Maintenance

Maintenance Procedures

This section describes the procedures that must be performed as a part of normal maintenance program. Regular servicing of equipment by licensed HVAC technician is highly recommended. Always disconnect electrical power to the unit before performing these procedures. It is always a safe practice to observe all safety warnings and cautions when conducting maintenance tasks.



DANGER

Live Electrical Connections !

It may be necessary to work with live electrical components on certain maintenance tasks. Only licensed electricians and qualified technicians are allowed to perform these tasks.



WARNING

Hazardous Voltage !

Always make sure that all power supply, including remote controls, are disconnected before performing maintenance. Observe proper LOCK-OUT / TAG-OUT (LOTO) procedures to ensure that power cannot be inadvertently energised. Failure to disconnect power before maintenance procedures can result in serious injury and/or death.

Annual Maintenance Checklists

- Perform general maintenance inspections.
- Perform scheduled start-up checks.
- Leak test refrigerant circuits.
- Inspect contacts of all contactors and relays. Replace all worn contacts as required.
- Inspect, clean and tighten all electrical connections.
- Check fans for balanced operation. Make sure that there are no loose screws/bolts, no fan blades interference and no damage to the fans and guards.
- Inspect the air filters, clean or replace as required.
- Clean and repaint any corroded panel section.
- Ensure no blockage of airflow through variable speed drive and drive fan is operating correctly.

Cleaning the Condenser Coils

Clean the coils at least once a year or more frequently if unit is located in a dusty and dirty environment, in order to maintain your system's proper operating performance. High discharge pressures are good indication that the coils need cleaning. When using detergent or solvents to clean the coils, follow the manufacturer's instructions to avoid potential damage to the coils and to the unit.

To clean the refrigerant coils, use a soft brush and water spray, such as garden hose or pressure washer with low pressure nozzle.



DANGER

Beware of Rotating Fan Blades !

- Always make sure that all power supply, to the Outdoor Fans are turned-off and isolated.
- Observe WH&S safety procedures, do not wear loose clothing and any jewellery when working near the fans.
- Wear PPE whenever performing any maintenance procedures.
- Observe all necessary procedures when working on a confined space.

 **CAUTION**

Do Not Use High Alkaline Detergent !

When using detergent for coil cleaning, ensure that the alkaline level is no higher than 8.5, which can cause corrosion damage to the coils.

Coil Cleaning Procedures

- Disconnect power to the unit.
- Remove the louvered panels from the unit to gain access to the air inlet side of the coils.
- Use a soft brush to remove loose dirt and debris from both sides of the coils.
- Straighten bent coil fins with fin comb.
- Prepare the detergent solutions according to the manufacturer’s instructions.
- Spray solution at a 90° angle to the coils, keeping a minimum nozzle spray angle of 15°, with at least a 1800mm distance from the coils and 600 psi pressure.
- Spray leaving air side of the coils first then the air inlet side. Allow the solution to stand on the coils for five minutes.
- Rinse both sides of the coils with cool clean water.
- Inspect the coils, if they are still dirty, repeat the cleaning procedure.
- Clean and wipe dry the outer and inner sides of the unit, the refrigerating parts and other components.
- Ensure that the condensate drain lines are not blocked.
- Reinstall all unit panels, covers and guards.
- Restore electrical power to the unit.

22. Maintenance Frequency Checklist

Regular servicing of equipment by a qualified technician is recommended every 12 months for residential applications and every quarter for commercial applications. Regular servicing of your unit helps in maintaining its optimum performance and reliability. **The following checklist and service periods are provided as a guide only, as some sites may require more frequent servicing.**

Electrical										
Parts	Service Frequency					Detail of Service Check	Service Methods			
	1 Mth	3 Mth	6 Mth	1 Yr	2 Yrs			3 Yrs	4 Yrs	5 Yrs
Printed Circuit Boards				✓		Visual Inspection.	Tighten Terminals as necessary on printed circuit boards.			
Electrical Connections				✓		Check all electrical terminals, mains, communications, etc.	Re-tighten if loose.			
Magnetic Contactor				✓		Check for loose terminal connections.	Tighten electrical terminals. Remove any dust.			

Outdoor Unit										
Parts	Service Frequency								Detail of Service Check	Service Methods
	1 Mth	3 Mth	6 Mth	1 Yr	2 Yrs	3 Yrs	4 Yrs	5 Yrs		
Casing/Panels and Frames				✓					Visual check for damage, rust and dust accumulation.	For highly corrosive environment, wash panels quarterly with water & neutral detergent solution. Wax panels. Repair / re-paint where required.
Insulation				✓					Visual check for insulation conditions.	Repair / replace insulation material.
Fan				✓					Visual check for run out of balance and dust accumulation.	Clean off dust as necessary to negate possibility of fan running out of balance.
Motor				✓ Ω					Visual check on wiring. Insulation resistance check to be carried out annually.	Measure insulation resistance. Should be more than 1MΩ.
Heat Exchanger				✓					Check for clogging by dust. Check for leaks / damage.	Clean air inlet side as necessary. Straighten any bent fins using fins comb.
Condensate Drain Line (if available)				✓					Check for obstructions & free flow of water.	Clean to eliminate obstructions/sludge & check condition of drain line. Pour water to ensure free flow.
Compressor				✓ Ω					Check for high / low pressure. Measure insulation resistance. Check compressor for abnormal noise/vibrations.	Measure insulation resistance. Should be more than 1MΩ. Ensure to isolate first the VSD from the compressor before measuring insulation resistance.
Compressor drive				✓					For variable drive compressor check full operation of drive from minimum hertz to maximum, check fan operation of drive.	Check compressor amperage & running frequency feedback from outdoor board seven segment display.
				✓					Ensure drive fresh air path is clear and drive fan is operating correctly.	Check ventilation holes on top and bottom of drive cover are clear of leaves, pebbles or dirt.
Refrigeration Operational Readings				✓					Make note of operational reading in test cool/heat mode.	Check operating pressures, record super heat & sub-cool values.
Safety Devices				✓					Check calibration of safety devices.	Check resistance of sensors, pressure cut in / cut out of pressure controls.
Faults				✓					Check for any previous fault history on unit.	Investigate any causes for previous faults, reset fault history.

Indoor Unit										
Parts	Service Frequency								Detail of Service Check	Service Methods
	1 Mth	3 Mth	6 Mth	1 Yr	2 Yrs	3 Yrs	4 Yrs	5 Yrs		
Casing/Panels and Frames				✓					Visual check for damage, rust and dust accumulation.	For highly corrosive environment, wash panels quarterly with water & neutral detergent solution. Wax panels. Repair / re-paint where required.
Insulation				✓					Visual check for insulation conditions.	Repair / replace insulation material.
Fan				✓					Visual check for run out of balance and dust attached.	Clean off dust as necessary to negate possibility of fan running out of balance.
Motor				✓ Ω					Visual check on wiring. Insulation resistance check to be carried out annually.	Measure insulation resistance to earth with Megger. Insulation resistance should be more than 1MΩ.
Heat Exchanger				✓					Check for clogging by dust. Check for leaks / damage.	Clean air inlet side as necessary. Straighten any bent fins using fins comb.
Drain Pan/ Condensation line				✓					Check for obstructions & free flow of water.	Clean to eliminate obstructions/ sludge & check condition of pan. Pour water to ensure free flow.
Filter*	✓								Check for clogging by dust.	Clean / Replace Filter.
Temperature Readings				✓					Measure air on & air off.	Place temperature probe in return & supply air of unit.

*Service period for filter cleaning may vary depending on operating time & surrounding environment



actronair.com.au

1300 522 722



©Copyright 2022 Actron Engineering Pty Limited ABN 34 002767240. ®Registered Trade Marks of Actron Engineering Pty Limited.
ActronAir is constantly seeking ways to improve the design of its products. Therefore, specifications are subject to change without notice.