

ECOFLEX MINI VRF R-32 SERIES

Floor Standing Unit

Installation and Commissioning Guide

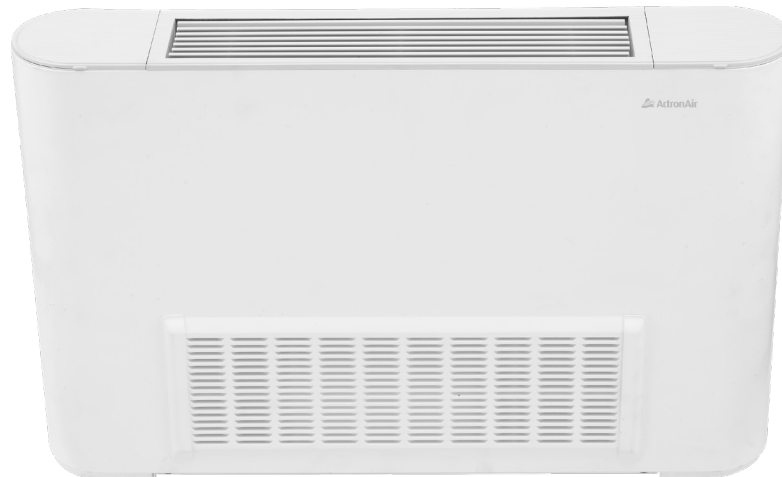

Model Numbers

MFF-022CS
MFF-028CS
MFF-036CS
MFF-045CS
MFF-056CS
MFF-071CS
MFF-080CS



CAUTION:

The system is charged with flammable refrigerant, safety checks are necessary to ensure that the risk of ignition is minimised.

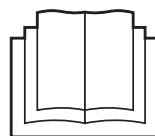

IMPORTANT NOTE:

Please read the R-32 Safety Manual and this manual carefully before installing or operating your air conditioning unit.

Information in this manual is to be used in conjunction with the R-32 Safety Manual.

Make sure to save this manual for future reference.



Table of Contents

01. Preface	3
02. Safety Warning	4
02.01. Warning Signs	4
02.02. Safety Precautions	5
02.03. Electric Safety Requirements	6
02.04. Appendix	7
03. PRECAUTIONS	10
03.01. Qualification and Safety Regulation Requirements	10
03.02. Precautions for Carrying and Lifting the Air Conditioner	11
03.03. Precautions for Installation sites	12
03.04. Recommended Installation Sites	12
04. Components Overview	14
05. Product Dimensions	15
06. Accessories	17
06.01. Accessories available to be purchased separately	17
06.02. Heat Insulation Material Requirements	18
07. Preparations Before Installation	19
07.01. Unpacking Check	19
08. Refrigerant Connecting Piping Installation	19
08.01. Length and Level Difference Requirements	19
08.02. Pipe Layout	20
08.03. Pipe Connection Steps	20
08.04. Pipe Connection	21
08.05. Refrigerant Piping Fixing	24
08.06. Vacuum Pumping	24
09. Drainage Pipe Installation	25
09.01. Installation of Water Discharge Pipe for the Indoor Unit	26
10. Electrical Connection	26
10.01. Electrical Characteristics	27
10.02. Schematic diagram of the main terminal blocks of main control board	28
10.03. Wiring	28
10.04. Power cable connection	29
11. Application Control	43
11.01. Error Codes and Definitions	43
11.02. Operating Status Codes and Definitions (Non-Error)	45
11.03. Spot Check Description	46
11.04. ESP Setting	47
12. Test Run	48
12.01. Before the Test Run, Make Sure That	48
12.02. Test Run	48
12.03. Indoor Unit	49
12.04. Outdoor Unit	49
12.05. Inspection After Installation	50

01. Preface

Dear users,

Thank you for purchasing and using our product. Please read this manual carefully before you install, use, maintain or troubleshoot this product so that you can familiarize yourself with the product and use it correctly.





For Outdoor Units or other Indoor Units, please refer to the applicable installation & owner's manuals provided with them.

For detailed operation of auxiliary control devices, such as wired, remote and centralized controllers, please refer to their instructions.

- To ensure the correct installation and operation of the product, the following instructions are provided:
- To ensure the correct and safe operation of the product, please strictly follow the requirements listed in this manual.
- All figures and contents in this manual are for reference only. Due to continuing product improvement, the specifications are subject to change without notice.
- Regular cleaning and maintenance of the product are required for intended performance and long service life. Each year before using the air conditioner, please contact your local dealer, and we will assign professionals to provide paid services of cleaning, maintenance, and inspection.
- Please retain this manual for future reference.



02. Safety Warning

Please thoroughly read and ensure that you fully understand the safety precautions (including the signs and symbols) in this manual, and follow relevant instructions during use to prevent damage to health or property.

	WARNING	This symbol shows that this appliance used a flammable refrigerant. If the refrigerant is leaked and exposed to an external ignition source, there is a risk of fire.
	CAUTION	This symbol shows that the operation manual should be read carefully.
	CAUTION	This symbol shows that a service personnel should be handling this equipment with reference to the installation manual.
	CAUTION	This symbol shows that information is available such as the operating manual or installation manual.

02.01. Warning Signs

Different marks are used to indicate the levels of hazard severity. Please follow the instructions and ensure safe operation:

	DANGER	Failure to observe the warning will result in severe personal injury or death.
	WARNING	Failure to observe the warning could result in severe personal injury or death, property damage, or electrical or fire hazards.
	CAUTION	Failure to observe the warning could result in minor personal injury, product or property damage, or other unsafe situations.
	NOTE	Useful operation and maintenance information.

Warning Contents



Ensure Proper Grounding



Professional Only

Prohibition signs



No Flammable Materials



No Strong Current



No Open Fire



No Acid or Alkali Materials

02.02. Safety Precautions

DANGER

During thunderstorms, disconnect the main power switch. Otherwise, lightning may damage the unit. In the event of refrigerant leakage, smoking and open flames are prohibited. Disconnect the main power switch immediately, open windows to allow ventilation, keep away from the leakage point, and contact your local dealer or technical support to request a professional repair.

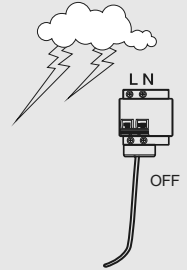

WARNING

Air conditioner installation must comply with local standards and electrical codes, and relevant instructions in this manual.

Do not use any liquid cleanser, liquefied cleanser, or corrosive cleanser to wipe this unit or spray water or other liquids on the unit. Otherwise, the plastic parts of the unit will become damaged and an electrical shock may occur. Disconnect the main power switch before cleaning and maintenance to avoid accidents.

Ask a professional to remove and reinstall the air conditioner. Ask a professional for maintenance and repair assistance..

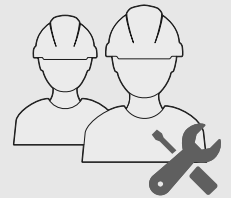

CAUTION

This appliance is not intended for use by persons (including children) with reduced physical, sensory or mental capabilities, or lack of experience and knowledge, unless they have been given supervision or instruction concerning use of the appliance by a person responsible for their safety.

Children should be supervised to ensure that they do not play with the appliance.

The units are partial unit air conditioners, complying with partial unit requirements of this International Standard, and must only be connected to other units that have been confirmed as complying to corresponding partial unit requirements of this International Standard.

02.03. Electric Safety Requirements

WARNING

- The air conditioner shall be installed according to the local wiring specifications. Wiring work must be completed by qualified electricians.
- All wiring work must comply with electrical safety specifications.
- The air conditioner must be well grounded. Specifically, the main switch of the air conditioner must have a reliable grounding cable.
- Before contacting wiring devices, cut off all the power supplies.
- The user **MAY NOT** disassemble or repair the air conditioner. Doing so can be dangerous. In the event of a fault, immediately cut off the power and contact your local dealer or technical support.
- A separate power supply that meets the rated parameter values must be provided for the air conditioner.
- The fixed wiring to which the air conditioner is connected must be equipped with a power cut-off device that meets the wiring requirements.
- To avoid danger, a damaged power cable must be replaced by professionals from the maintenance department or a similar department of the manufacturer.
- The air conditioner's circuit board (PCB) is designed with a fuse to provide overcurrent protection.
- The specifications of the fuse are printed on the circuit board.

NOTE: For the units with R-32 refrigerant, only the blast-proof ceramic fuse can be used.

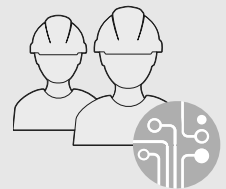
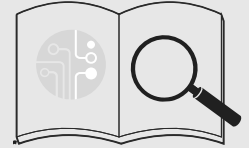

CAUTION

Always ground the main power switch.

Do not use a damaged power cable and replace it if it is damaged.

When the air conditioner is used for the first time or is in a power-off state for a long time, it needs to be connected to the power supply and warmed up for at least 12 hours before use.

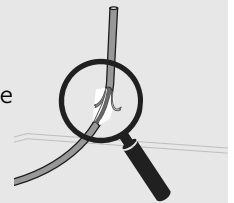

02.04. Appendix

WARNING

The following applies to R-32 refrigerant systems.

- Prior to beginning work on systems containing flammable refrigerants, safety checks are necessary to ensure that the risk of ignition is minimized.
- For repair to the refrigerating system, the following precautions shall be complied with prior to conducting work on the system.
- Work shall be undertaken under a controlled procedure so as to minimise the risk of a flammable gas or vapour being present while the work is being performed.
- All maintenance staff and others working in the local area shall be instructed on the nature of work being carried out. Work in confined spaces shall be avoided. The area around the workspace shall be sectioned off. Ensure that the conditions within the area have been made safe by control of flammable material.
- The area shall be checked with an appropriate refrigerant detector prior to and during work, to ensure the technician is aware of potentially flammable atmospheres.
- Ensure that the leak detection equipment being used is suitable for use with flammable refrigerants, i.e. non-sparking, adequately sealed or intrinsically safe.
- If any hot work is to be conducted on the refrigeration equipment or any associated parts, appropriate fire extinguishing equipment shall be available to hand. Have a dry powder or CO2 fire extinguisher adjacent to the charging area.
- No person carrying out work in relation to a refrigeration system which involves exposing any pipe work that contains or has contained flammable refrigerant shall use any sources of ignition in such a manner that it may lead to the risk of fire or explosion.
- All possible ignition sources, including cigarette smoking, should be kept sufficiently far away from the site of installation, repairing, removing and disposal, during which flammable refrigerant can possibly be released to the surrounding space.
- Prior to work taking place, the area around the equipment is to be surveyed to make sure that there are no flammable hazards or ignition risks. “No Smoking” signs shall be displayed.
- Ensure that the area is in the open or that it is adequately ventilated before breaking into the system or conducting any hot work. A degree of ventilation shall continue during the period that the work is carried out. The ventilation should safely disperse any released refrigerant and preferably expel it externally into the atmosphere.
- Where electrical components are being changed, they shall be fit for the purpose and to the correct specification. At all times the manufacturer’s maintenance and service guidelines shall be followed. If in doubt consult the manufacturer’s technical department for assistance.
- The following checks shall be applied to installations using flammable refrigerants:
 1. the charge size is in accordance with the room size within which the refrigerant containing parts are installed;
 2. the ventilation machinery and outlets are operating adequately and are not obstructed;
 3. if an indirect refrigerating circuit is being used, the secondary circuit shall be checked for the presence of refrigerant;
 4. marking to the equipment continues to be visible and legible. Markings and signs that are illegible shall be corrected;
 5. refrigeration pipe or components are installed in a position where they are unlikely to be exposed to any substance which may corrode refrigerant containing components, unless the components are constructed of materials which are inherently resistant to being corroded or are suitably protected against being so corroded.
- Repair and maintenance to electrical components shall include initial safety checks and component inspection procedures.

- If a fault exists that could compromise safety, then no electrical supply shall be connected to the circuit until it is satisfactorily dealt with. If the fault cannot be corrected immediately but it is necessary to continue operation, an adequate temporary solution shall be used. This shall be reported to the owner of the equipment so all parties are advised.
- Initial safety checks shall include:
 1. that capacitors are discharged: this shall be done in a safe manner to avoid possibility of sparking;
 2. that no live electrical components and wiring are exposed while charging, recovering or purging the system;
 3. that there is continuity of earth bonding.
- During repairs to sealed components, all electrical supplies shall be disconnected from the equipment being worked upon prior to any removal of sealed covers, etc. If it is absolutely necessary to have an electrical supply to equipment during servicing, then a permanently operating form of leak detection shall be located at the most critical point to warn of a potentially hazardous situation.
- Particular attention shall be paid to the following to ensure that by working on electrical components, the casing is not altered in such a way that the level of protection is affected. This shall include damage to cables, excessive number of connections, terminals not made to original specification, damage to seals, incorrect fitting of glands, etc.
- Ensure that seals or sealing materials have not degraded such that they no longer serve the purpose of preventing the ingress of flammable atmospheres.
- Replacement parts shall be in accordance with the manufacturer's specifications.
- Do not apply any permanent inductive or capacitance loads to the circuit without ensuring that this will not exceed the permissible voltage and current permitted for the equipment in use.
- Intrinsically safe components are the only types that can be worked on while live in the presence of a flammable atmosphere. The test apparatus shall be at the correct rating.
- Replace components only with parts specified by the manufacturer. Other parts may result in the ignition of refrigerant in the atmosphere from a leak.
- Check that cabling will not be subject to wear, corrosion, excessive pressure, vibration, sharp edges or any other adverse environmental effects. The check shall also take into account the effects of ageing or continual vibration from sources such as compressors or fans.
- When breaking into the refrigerant circuit to make repairs – or for any other purpose – conventional procedures shall be used. However, it is important that best practice is followed.
- Since flammability is a consideration. The following procedure shall be adhered to:
 - remove refrigerant;
 - purge the circuit with inert gas;
 - evacuate;
 - purge again with inert gas;
 - open the circuit by cutting or brazing.
- The refrigerant charge shall be recovered into the correct recovery cylinders. The system shall be "flushed" with OFN to render the unit safe. This process may need to be repeated several times. Compressed air or oxygen shall not be used for this task.
- Flushing shall be achieved by breaking the vacuum in the system with OFN and continuing to fill until the working pressure is achieved, then venting to atmosphere, and finally pulling down to a vacuum.
- This process shall be repeated until no refrigerant is within the system. When the final OFN charge is used, the system shall be vented down to atmospheric pressure to enable work to take place.
- This operation is absolutely vital if brazing operations on the pipe-work are to take place.
- Ensure that the outlet for the vacuum pump is not close to any ignition sources and there is ventilation available.
- Ensure that contamination of different refrigerants does not occur when using charging equipment. Hoses or lines shall be as short as possible to minimise the amount of refrigerant contained in them.
- Prior to recharging the system it shall be pressure tested with OFN.

- DD.12 Decommissioning:

Before carrying out this procedure, it is essential that the technician is completely familiar with the equipment and all its detail. It is recommended good practice that all refrigerants are recovered safely. Prior to the task being carried out, an oil and refrigerant sample shall be taken in case analysis is required prior to re-use of reclaimed refrigerant. It is essential that electrical power is available before the task is commenced.

1. Become familiar with the equipment and its operation.
 2. Isolate system electrically.
 3. Before attempting the procedure ensure that:
 - mechanical handling equipment is available, if required, for handling refrigerant cylinders;
 - all personal protective equipment is available and being used correctly;
 - the recovery process is supervised at all times by a competent person;
 - recovery equipment and cylinders conform to the appropriate standards.
 4. Pump down refrigerant system, if possible.
 5. If a vacuum is not possible, make a manifold so that refrigerant can be removed from various parts of the system.
 6. Make sure that cylinder is situated on the scales before recovery takes place.
 7. Start the recovery machine and operate in accordance with manufacturer's instructions.
 8. Do not overfill cylinders. (No more than 80 % volume liquid charge).
 9. Do not exceed the maximum working pressure of the cylinder, even temporarily.
 10. When the cylinders have been filled correctly and the process completed, make sure that the cylinders and the equipment are removed from site promptly and all isolation valves on the equipment are closed off.
 11. Recovered refrigerant shall not be charged into another refrigeration system unless it has been cleaned and checked.
- Equipment shall be labelled stating that it has been de-commissioned and emptied of refrigerant. The label shall be dated and signed. Ensure that there are labels on the equipment stating the equipment contains flammable refrigerant.
 - When removing refrigerant from a system, either for servicing or decommissioning, it is recommended good practice that all refrigerants are removed safely.
 - When transferring refrigerant into cylinders, ensure that only appropriate refrigerant recovery cylinders are employed. Ensure that the correct number of cylinders for holding the total system charge are available. All cylinders to be used are designated for the recovered refrigerant and labelled for that refrigerant (i.e. special cylinders for the recovery of refrigerant). Cylinders shall be complete with pressure relief valve and associated shut-off valves in good working order. Empty recovery cylinders are evacuated and, if possible, cooled before recovery occurs.
 - The recovery equipment shall be in good working order with a set of instructions concerning the equipment that is at hand and shall be suitable for the recovery of flammable refrigerants. In addition, a set of calibrated weighing scales shall be available and in good working order. Hoses shall be complete with leak-free disconnect couplings and in good condition. Before using the recovery machine, check that it is in satisfactory working order, has been properly maintained and that any associated electrical components are sealed to prevent ignition in the event of a refrigerant release. Consult manufacturer if in doubt.
 - The recovered refrigerant shall be returned to the refrigerant supplier in the correct recovery cylinder, and the relevant Waste Transfer Note arranged. Do not mix refrigerants in recovery units and especially not in cylinders.
 - If compressors or compressor oils are to be removed, ensure that they have been evacuated to an acceptable level to make certain that flammable refrigerant does not remain within the lubricant. The evacuation process shall be carried out prior to returning the compressor to the suppliers. Only electric heating to the compressor body shall be employed to accelerate this process. When oil is drained from a system, it shall be carried out safely.
 - Warning: disconnect the appliance from its power source during service and when replacing parts.
 - These units are partial unit air conditioners, complying with partial unit requirements of this International Standard, and must only be connected to other units that have been confirmed as complying to corresponding partial unit requirements of this International Standard.

03. PRECAUTIONS

03.01. Qualification and Safety Regulation Requirements

WARNING

- **Please carry out the installation according to local standards.**
- **Ask your local dealer or professionals to install the product.**

This unit must be installed by professional technicians with relevant specialized knowledge. Users MAY NOT install the unit themselves; otherwise, faulty operations may cause the risks of fire, electrical shock, injury, or leakage, which could harm you or others or damage the air conditioner.
- **Never modify or repair the unit on your own.**

Otherwise, a fire, electric shock, injury or water leakage may occur. Get your local dealer or a professional to do so.
- **Ensure that the residual current device (RCD) is installed.**

The RCD must be installed. Failure to install it may result in electric shock.
- **When powering the unit, follow the regulations of the local electric company.**

Make sure that the unit is grounded reliably in accordance with laws. If the grounding is not completed correctly, it may cause electrical shock.
- **When moving, disassembling or reinstalling the air conditioner, get the assistance of your local dealer or a professional.**

If installed improperly, fire, electrical shock, injury, or water leakage may occur.
- **Use the optional accessories specified by our company.**

The installation of these accessories must be carried out by professionals. Improper installation may cause fire, electrical shock, water leakage and other hazards.
- **Use only power cables and communication cables that meet specification requirements. Properly connect all the wiring to make sure that no external forces are acting on the terminal blocks, power cables and communication cables. Improper wiring or installation may cause a fire.**
- **The air conditioner must be grounded. Check whether the earth line is securely connected or broken. Do not connect the ground line to gas cans, water piping, lightning rods or telephone earth lines.**
- **The main power switch of the air conditioner should be put in a position that is out of the reach of children.**

It should not be obstructed by flammable objects such as curtains.
- **Open flames are prohibited when refrigerant leaks are present.**

If the air conditioner is not cooling/heating properly, this may be caused by a refrigerant leak. If this occurs, contact your local dealer or a professional.

The refrigerant in the air conditioner is safe, and usually does not leak. If there is refrigerant leakage in the room, it is easy for a fire to occur after contact with the heating units of the heater/electric stove/stove. Please disconnect the power supply of the air conditioner, extinguish the flames of appliances that produce a flame, and open the windows and doors of the room to allow ventilation and ensure that the concentration of refrigerant leakage in the room does not exceed a critical level; keep away from the leakage point, and contact the dealer or professional personnel.
- **After the refrigerant leakage is repaired, do not start the product until the maintenance personnel confirms that the leakage is fully repaired.**
- **Before and after installation, exposing the unit to water or moisture will cause electrical parts short circuiting.**

Do not store the unit in a humid basement or expose it to rain or water.
- **Make sure the installation base and lifting are robust and reliable;**

Insecure installation of the base may cause the air conditioner to fall, leading to an accident. Take into full consideration the effects of strong winds, typhoons and earthquakes, and reinforce the installation.
- **Check whether the drainage pipe can drain the water smoothly.**

Improper installation of the pipeline may lead to water leakage, damaging furniture, electric appliances, and the carpet.
- **After installation, check whether the refrigerant is leaking.**
- **Do not install the product in a location where there is a danger of flammable gas leaks.**

In the event of leakage of combustible gas, the combustible gas surrounding the Indoor Unit may cause a fire.
- **Install an air filter of 30-80 mesh/inch at the return air grille to filter dust in the air and keep the air diffuser clean and free from dirt blockage.**

 **WARNING**

- **Keep the Indoor Unit, Outdoor Unit, power cable, and connecting wires at least 1m away from the high-power radio equipment, to prevent electromagnetic interference and noise. For some electromagnetic waves, it is not enough to prevent noise even at a distance of more than 1m.**
- **In a room equipped with fluorescent lamps (rectifier type or fast start type), the signal transmission distance of the remote controller (wireless) may not reach the predetermined value. Install the Indoor Unit as far away from the fluorescent lamp as possible.**
- **Do not touch the fins of the heat exchanger, as this could cause injury.**
- **For safety, please dispose of the packing materials properly.**
Nails and other packaging materials may cause personal injury or other risks. Tear up the plastic packaging bag and dispose of it properly to prevent children from playing with it, leading to suffocation.
- **Do not cut off the power supply immediately after the Indoor Unit stops running.**
Some parts of the Indoor Unit like the valve body and water pump are still in operation. Please wait for at least 5 minutes before cutting off the power supply. Otherwise, water leakage and other faults may occur.
- **If the temperature and humidity in the ceiling mezzanine may exceed 30 RH80%, please put insulation material on the unit.**
Please use glass wool or foamed polyethylene as insulation material, the thickness of which is required to be 10mm or more, and can be stored in the ceiling opening.
- **For evaporating units and condensing units, the instructions or markings shall include a wording to assure that the maximum operating pressure is considered when connecting to any condenser unit or evaporator unit.**
- **For evaporating units, condensing units and condenser units, the instructions or markings shall include refrigerant charging instructions.**
- **A warning to assure that partial units shall only be connected to an appliance suitable for the same refrigerant.**
- **This unit is a partial unit air conditioner, complying with partial unit requirements of this International Standard, and must only be connected to other units that have been confirmed as complying to corresponding partial unit requirements of this International Standard.**
- **The electrical interfaces shall be specified with purpose, voltage, current, and safety class of construction. The SELV connection points, if provided, are to be clearly indicated in the instructions.**
- **The connection point should be marked with the “read the instructions” symbol per ISO 7000-0790 (2004-01) and the Class III symbol according to IEC 60417-5180 (2003-02).**

NOTE

This unit is equipped with a refrigerant leak detector for safety. To be effective, the unit must be electrically powered at all times after installation, other than when servicing.

If any supplemental unit is employed to detect leaked refrigerant, such unit shall also apply this marking or be accompanied by such instructions.

03.02. Precautions for Carrying and Lifting the Air Conditioner

1. Before carrying the air conditioner, determine the route that will be used to move it to the installation site.
2. Do not unseal the air conditioner until it is moved to the installation site.
3. When unpacking and moving the air conditioner, you must hold the hanger seat and not apply force to other parts, especially the refrigerant piping, drainage pipe and plastic accessories, so as to avoid damaging the air conditioner and causing personal injury.
4. Before installing the air conditioner, make sure that the refrigerant specified on the nameplate is used. For the installation of the Outdoor Unit, refer to the installation instructions in the Installation & Owner's Manual attached with the Outdoor Unit.

03.03. Precautions for Installation sites

WARNING

Do not install or use the air conditioner in the following places

- A place filled with mineral oil, fumes or mist, like a kitchen. Plastic parts will age and the heat exchanger will become dirty, eventually causing the air conditioner performance to deteriorate or leak water.
- A place where there are corrosive gases, such as acid or alkaline gases. Copper pipes and copper welds will be corroded, resulting in refrigerant leakage.
- A place exposed to combustible gases and using volatile combustible gases such as diluent or gasoline. The electronics in the air conditioner may cause the surrounding gas to ignite.
- A place where there is equipment emitting electromagnetic radiation. The control system will fail and the air conditioner will not function properly.
- A place where there is a high salt content in the air like a coastal area.
- A place where an explosion may occur.
- In vehicles or cabin rooms.
- Factories with major voltage fluctuations in the power supplies.
- Other special environmental conditions.

NOTE

Air conditioner units of this series are designed to provide comfort. Do not use them in equipment rooms and rooms with precision instruments, food, plants, animals, or works of art.

03.04. Recommended Installation Sites

03.04.01. Selection principle for the installation site

It is recommended to install the air conditioner according to the design drawing of the HVAC engineer. The selection principle for the installation site is as follows:

1. Ensure that the airflow in and out of the Indoor Unit is reasonably organized to form an air circulation in the room.
2. Ensure Indoor Unit maintenance space.
3. The nearer the drainage pipe and copper pipe are to the Outdoor Unit, the lower the pipe cost is.
4. Prevent the air conditioner from blowing directly at the human body.
5. The closer the wiring is to the power cabinet, the lower the wiring cost is.
6. Keep the air-conditioning return air away from direct exposure to the sun in the room.
7. Be careful not to interfere with the light tank, fire pipe, gas pipe and other facilities.
8. The Indoor Unit should not be lifted in the places like load-bearing beams and columns that affect the structural safety of the house.
9. The wired controller and the Indoor Unit should be in the same installation space; otherwise, the sampling point setting of the wired controller needs to be changed.

Choose a site that fully complies with the following conditions and user requirements to install the air conditioning unit:

- Well ventilated. Unobstructed airflow.
- Strong enough to bear the weight of the indoor unit. Ceiling has no obvious slant.
- There is sufficient space for repair and maintenance work to be carried out.
- No leakage of flammable gas.
- The length of the piping between the indoor and outdoor units is within the permitted range (refer to the manual on installation of the outdoor unit).
- Space required for installation (unit (mm)):
 - Incorrect positioning or installation may increase the noises and vibration of the unit during operation.
 - If not enough space is reserved during installation, the unit may face difficult maintenance and reduced performance.
 - The unit allows vertical installation, provided that correct positioning is arranged in advance. As shown below, a is greater than 150 mm, b is between 90 and 100 mm, c greater than 50 mm and d greater than 1500 mm.
 - The footings shown in are optional. You can purchase them separately.
- The symbols above is for R-32 refrigerant system.
 - For installations with field applied mechanical joints which are exposed in the occupied space, the instructions shall state that a sensor shall be located.
 - Remote located within 2 m horizontal distance in line of the until and on a wall within the room in which the unit is installed; and 100 mm above the floor .

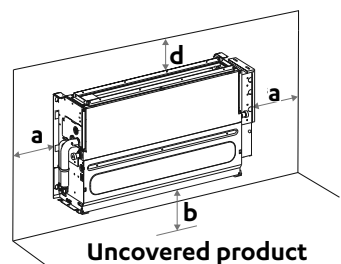
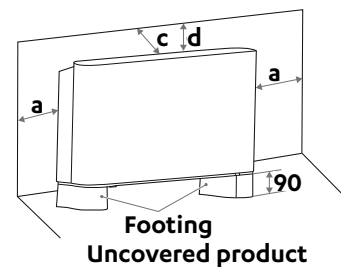
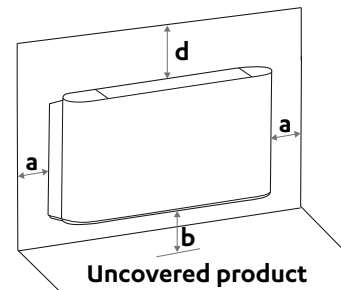

04. Components Overview

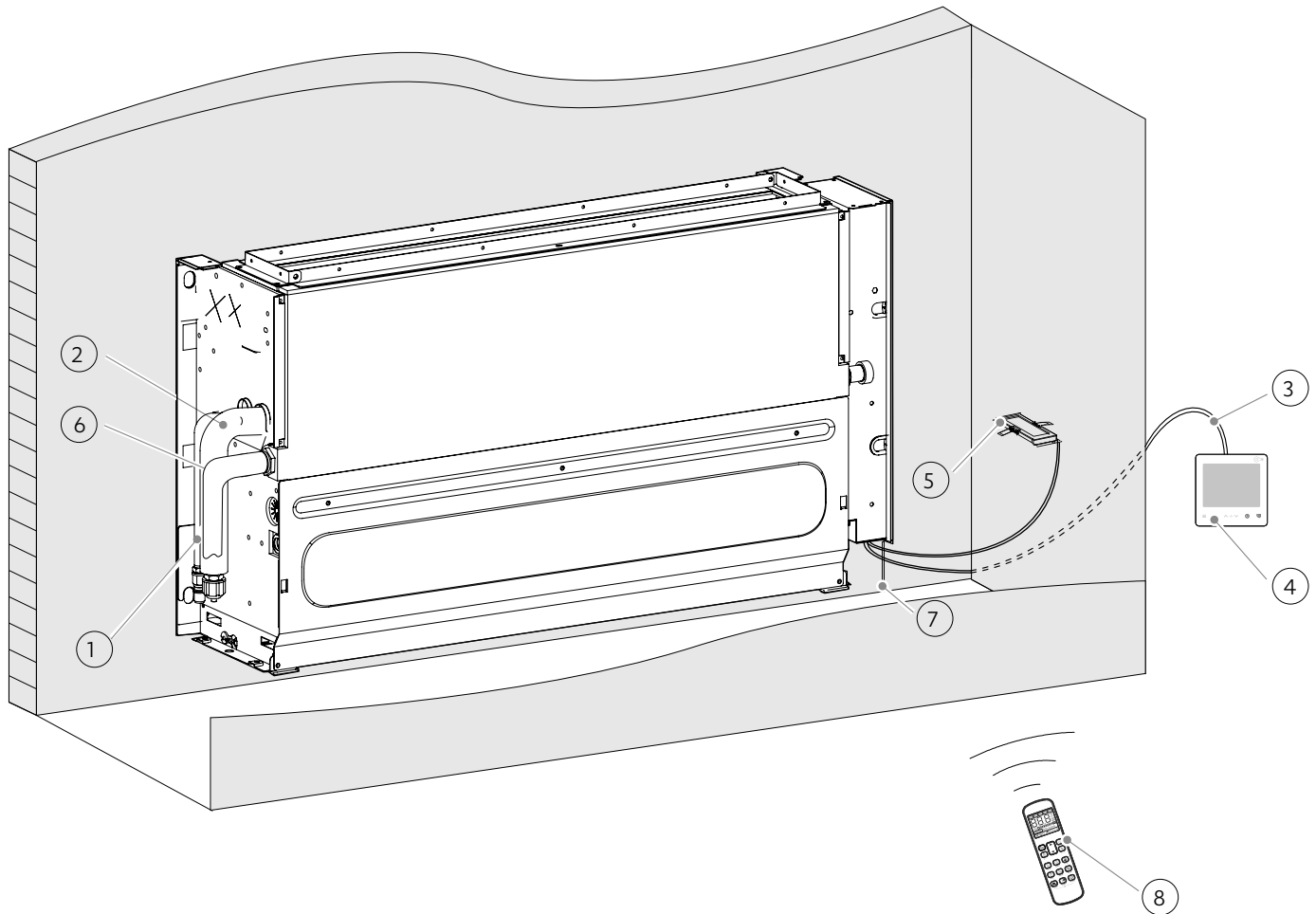

1	Gas pipe	5	Display box (optional)
2	Liquid pipe	6	*Drainage pipes for models
3	*Connection wire	7	*Power cable and ground wire
4	Wired controller (optional)	8	Remote controller (optional)

* To be purchased separately.

NOTE

- All optional items can be purchased from ActronAir.
- For optional accessories such as wired controllers, please refer to the instructions of the product.
- All the figures in the manual explain only the general appearance and functions of the product. The appearance and functions of the product you purchased may not be completely consistent with those listed in the figures. Please refer to the actual product.

05. Product Dimensions

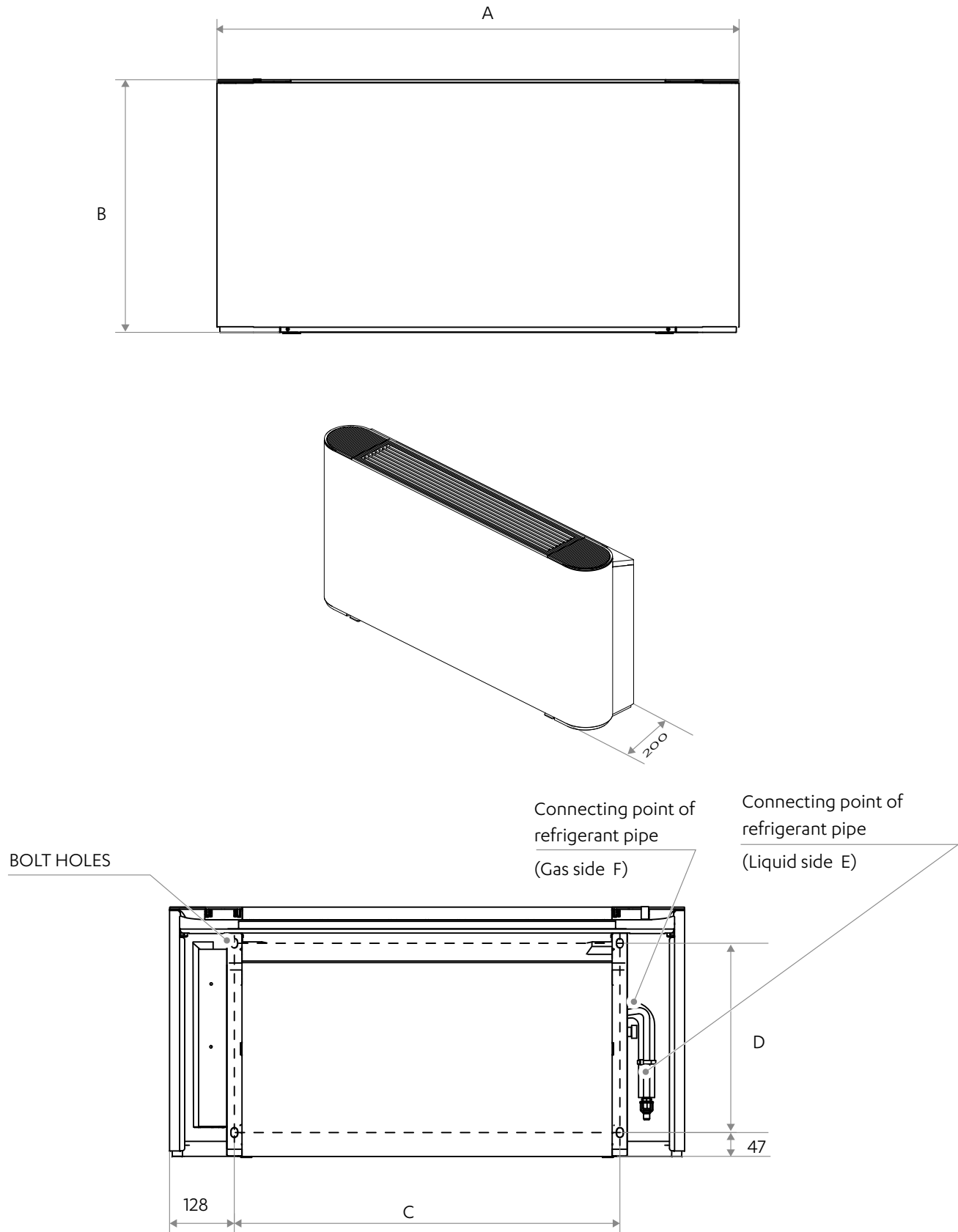

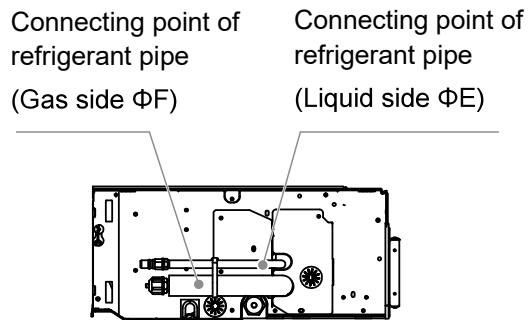
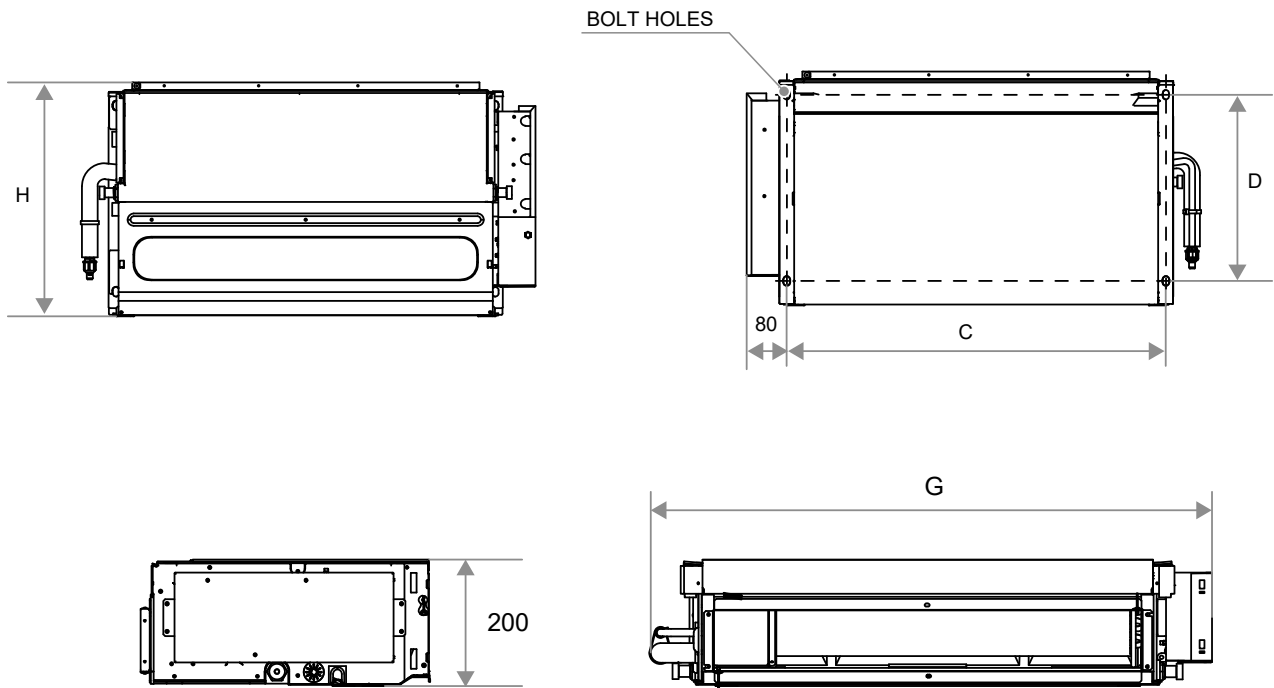

Capacity (kW)	Unit: mm						
	2.2	2.8	3.6	4.5	5.6	7.1	8.0
A	1020	1020	1020	1240	1360	1360	1360
B	495	495	495	495	591	591	591
C	764	764	764	984	1104	1104	1104
D	375	375	375	375	391	391	391
E	6.4	6.4	6.4	6.4	6.4	9.5	9.5
F	12.7	12.7	12.7	12.7	12.7	15.9	15.9
G	915	915	915	1133	1253	1253	1253
H	470	470	470	470	566	566	566

06. Accessories

List of accessories			
Installation & Owner's Manual X 1 Indoor Unit Installation Instructions (Make sure to hand it over to the user)	Brass nut X 2 For use in the installation of connecting pipe (the quantity is one for models with a process pipe)	Pipe thermal insulation X 2 Used for insulation and anti-condensation at pipe connections.	Base X 2 For some units (F3)
			Foot bolt X 4

CAUTION

When installing the insulation pipe on site, please cut it according to the actual needs. (Either method (a) or (b) is OK. Method (c) is incorrect. There must be no gap between the insulation pipe and the copper pipe.)

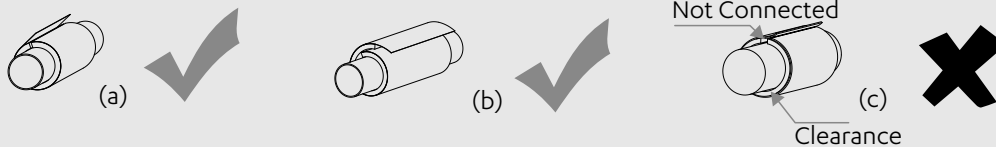

06.01. Accessories available to be purchased separately

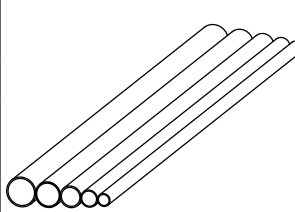
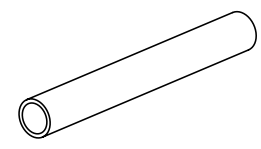
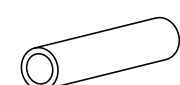
	Copper pipe specification (Unit: mm)		
	Model (kW)	Piping	Liquid side
	kW≤5.6		Ø6.35×0.75
	5.6<kW≤16		Ø9.52×0.75
Remarks	For connection of the Indoor Unit refrigerant system, it is recommended to use a soft copper tube (T2M), with the length selected according to the actual situation.		
	PVC water discharge pipe		Pipe thermal insulation
	This is used as the Indoor Unit's drainage pipe, 18mm in diameter. The length is determined according to actual needs.		The thickness of the insulation pipe for the copper pipe is usually 10mm or above; and the thickness of the insulation pipe for the rigid polyethylene plastic tube is usually 15mm or above. If the pipe is used in a closed humid area, the thickness should be increased.

CAUTION

Materials, including copper pipes, drainage pipes, lifting screws, various fasteners (such as pipe supports, clamps, screws), power cables, and signal cables, to be used for field installation need to be purchased on site by the installation operator. Materials and specifications must comply with relevant national or industry standards.

06.02. Heat Insulation Material Requirements

Copper pipe insulation	1	Use the closed-cell foam insulation material, which is rated at a flame retardancy level of B1 and heat resistance of over 120°C.
	2	Thickness of the insulation pipe: 1. When the diameter is equal to or greater than 15.9mm, the insulation thickness is at least 20mm. 2. When the diameter is equal to or smaller than 12.7mm, the insulation thickness is at least 15mm.
	3	For insulation of the outdoor copper pipe, the wall thickness of insulation pipes for winter heating systems is generally increased to over 40mm in regions with severe cold. For insulation of the indoor gas pipe, the wall thickness of insulation pipes is usually greater than 20mm.
	4	Use glue to connect the joints and cuts of the thermal insulation pipe, and then wrap them with electrical tape with a width of not less than 50mm to ensure the connection is firm.
	5	The insulation between the copper pipe and the Indoor Unit should be tight to prevent the generation of condensed water.
	6	After the system leakage detection test indicates that there are no leaks, carry out the insulation of the copper pipe.
Air duct insulation	1	Insulate the FCU components and the unit after the FCU system passes the air leakage test or quality check.
	2	Use centrifugal glass wool, rubber and plastic materials or other types of materials for thermal insulation. The insulation layer shall be smooth and dense without cracks or gaps.
	3	The supports, suspension brackets, and brackets of the air duct shall be arranged outside the insulation layer with sole timber.
	4	Insulation thickness: 1. The thickness of the insulation layer shall not be less than 40mm if the layer is made of centrifugal glass wool and is used for the air supply pipes and air return pipes in rooms without air conditioning. 2. The thickness of the insulation layer shall not be less than 25mm if the layer is made of centrifugal glass wool and is used for the air supply pipes and air return pipes in rooms with air conditioning. 3. If the insulation layer is made of rubber and plastic materials or other materials, the thickness of the insulation layer shall be obtained according to design requirements or calculation results.
Drainage pipe insulation	1	Indoor parts of the drainage pipe shall be insulated to prevent condensation, and protective sleeves should be thicker than 10mm.
	2	If the pipe is not wholly insulated, be sure to rebind the cut part.
	3	Use glue or buckles to connect the joints and cuts of the thermal insulation pipe, and make sure it is at the top of the pipe.
	4	Use glue or buckles to connect the joints and cuts of the thermal insulation pipe, and make sure it is at the top of the pipe.



The materials and specifications of insulation materials must meet national or industry standards.

07. Preparations Before Installation

07.01. Unpacking Check

1. Before installation, check whether the packing materials are in good condition, whether the accessories that come with the product are complete, whether the air conditioner is intact, whether the surfaces of the heat exchanger and other parts have become worn, and whether there are oil stains on the check valve of the unit.
2. Check the two sealing nut of the refrigerant pipe, and observe whether the red dot on the surface of the sealing nut of the gas pipe bulges. If it bulges, the pipe is well-sealed; if it retracts, the line is leaking, and you need to contact your local dealer.

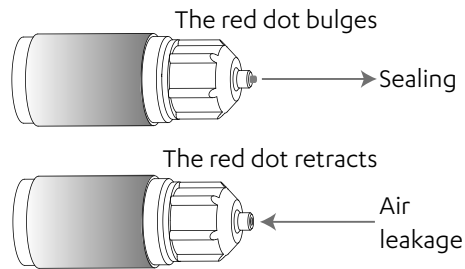

3. Check the machine model before installation.
4. After Indoor Unit and Outdoor Unit inspection, pack them with plastic bags to avoid intake of foreign matters.

08. Refrigerant Connecting Piping Installation

08.01. Length and Level Difference Requirements for the Pipe Connections of Indoor Unit and Outdoor Unit.

Different Outdoor Units have different requirements for length and level differences for the piping. Refer to the Installation & Owner's Manual attached with the Outdoor Unit.

WARNING

- During the installation of the connecting pipes, do not allow air, dust, and other debris to penetrate the piping system, and make sure the interior of the pipes is dry.
- Install the connecting pipes only when the Indoor Units and Outdoor Units are secured.
- When installing the connecting pipes, record the actual installation length of the liquid pipe on the spot so that additional refrigerant can be added.
- The copper pipes must be wrapped with thermal insulation materials when they are installed. In the event of refrigerant gas leakage during operation, please ventilate immediately.

08.02. Pipe Layout

1. Bend the pipes or punch holes in the wall as needed. The deformed pipe area must not exceed 15% of the total area. A protective casing should be installed at the wall or floor hole. The weld joint must not be inside the casing. The drill hole on the external wall must be sealed and tightly wrapped with a binding tie to prevent impurities from entering the pipe. The pipe must be insulated with the correctly-sized insulation pipe.

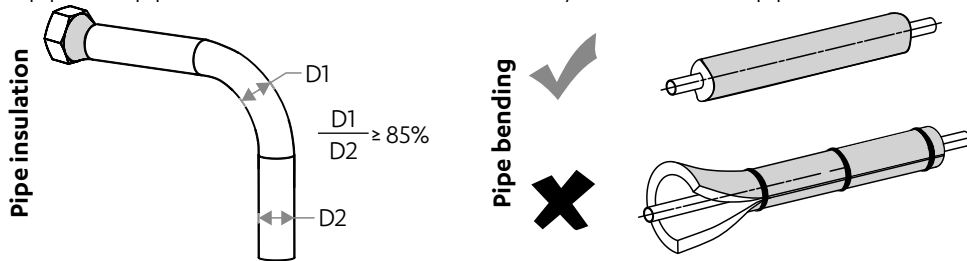

NOTE

D1 is the minimum diameter, and D2 is the nominal diameter.

2. The wrapped connecting pipe is plugged through the wall hole sleeve from the outdoor side and enters the indoor side. The pipes must be arranged carefully so as not to damage the piping.

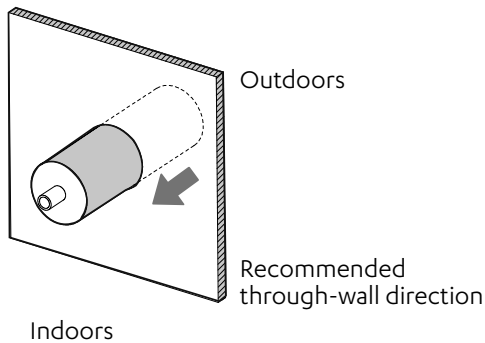

08.03. Pipe Connection Steps

Measure the required length of the connecting pipe. Make the connecting pipe using the following method (see “Pipe Connection” for details).

1. Connect the Indoor Unit first, then connect the Outdoor Unit.

Before tightening the flare nut, apply refrigeration oil on the inner and outer surface of the pipe flare (you must use refrigeration oil compatible with the refrigerant for this model), and turn it 3 or 4 turns by hand to tighten it. When connecting or removing a pipe, use two wrenches at the same time.

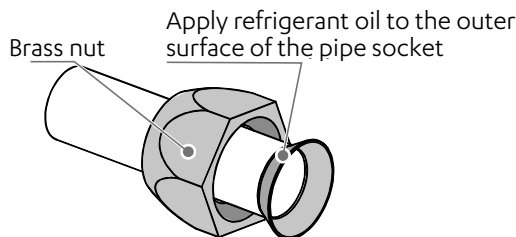

⚠ CAUTION

✓ Bend and arrange pipes carefully without damaging the pipes and their insulating layers.



Do not let the interface of the Indoor Unit bears the weight of the connecting pipe; otherwise, the connecting pipe may be crushed and deformed, which will affect the unit's cooling (heating) abilities, or the thermal insulation materials may become compressed, resulting in air leakage and condensation.

- The check valve of the Outdoor Unit is completely closed when leaving the factory. Unscrew brass nuts from the check valve in each connection, and connect the flared tube within 5 minutes. When the brass nuts at the check valve are removed and placed somewhere for too long, dust and other sundries may enter the pipeline system and cause failures after extended periods of operation.
- After the refrigerant piping is connected to the Indoor Unit and Outdoor Unit, follow the operations in the section titled "Vacuum pumping" to exhaust the air. After the air is exhausted, tighten the maintenance nut.

08.04. Pipe Connection

Bend the pipe with your thumb

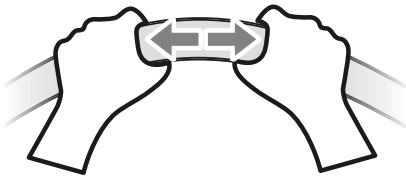

Processing method

- Hand bending processing: Applicable to thin copper pipes ($\varnothing 6.35\text{mm} - \varnothing 12.7\text{mm}$).
- Mechanical bending processing: Wider application ($\varnothing 6.35\text{mm} - \varnothing 28\text{mm}$), using spring pipe bender, manual pipe bender or electric pipe bender.

⚠ CAUTION

- The bending angle should not exceed 90° ; otherwise, wrinkles will be formed in the pipe, which can easily break.
- The bending radius should not be smaller than $3.5D$ (pipe diameter) and should be as large as possible to prevent the pipe from becoming flattened or crushed.
- When mechanically bending the pipe, the pipe bender inserted into the copper pipe must be cleaned.

08.04.01. Brazing pipes

When brazing pipes, fill the pipes with nitrogen. First evenly heat the inner pipes, then the outer pipes, and fill the joints with welding material.

⚠ WARNING

- When it is necessary to fill the piping with nitrogen during welding, the pressure must be kept at 0.02MPa using a pressure relief valve.
- Do not use flux when soldering the refrigerant connection piping. Use a phosphor copper solder that does not require flux.
- Do not use any antioxidants when soldering the piping. The piping may become clogged with residual antioxidants, which may block components such as electronic expansion valves during operation.

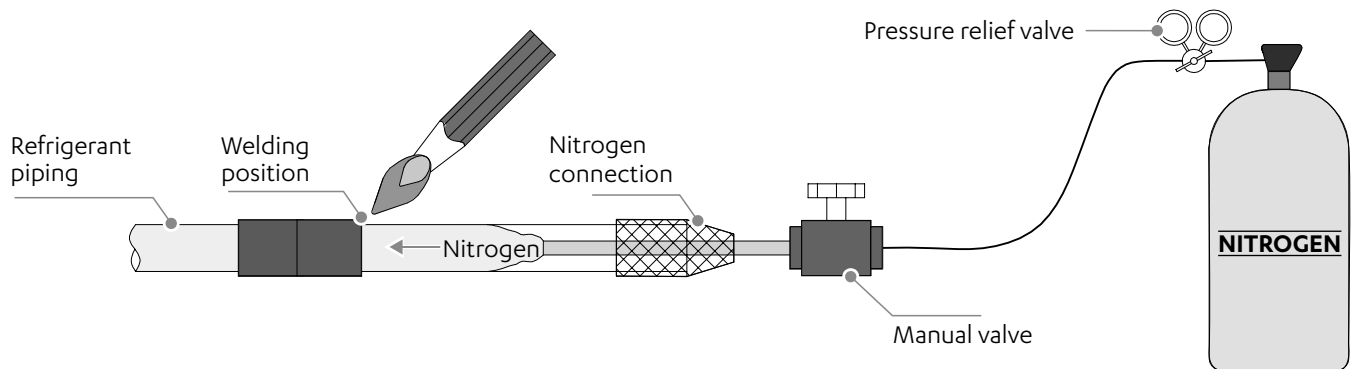

08.04.02. Flaring

To cut the piping with a pipe cutter, rotate the pipe cutter repeatedly.

Put the pipe into the connecting nut flaring, and both the gas pipe and liquid pipe of the Indoor Unit are connected by flaring.

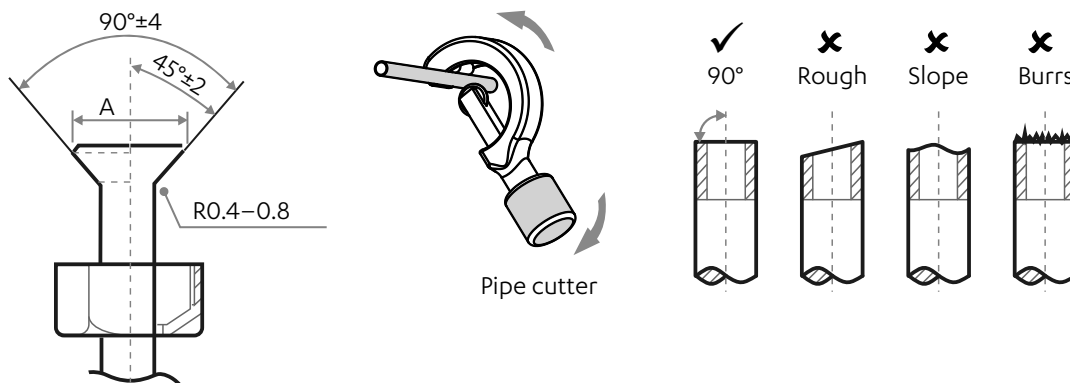

Outer diameter (mm)	A (mm)	
	Max.	Min.
Ø6.35	8.7	8.3
Ø9.52	12.4	12.0
Ø12.7	15.8	15.4
Ø15.9	19.1	18.6
Ø19.1	23.3	22.9

08.04.03. Nut fastening

1. Align the connecting piping, firstly tighten most of the thread of the connecting nut by hand, and then use a wrench to tighten the last 1-2 turns of the thread as shown in the figure.
2. The welding is done on site, and the bell mouth cannot be used indoors.(For IEC/EN 60335-2-40 except IEC 60335-2-40: 2018)
3. The protective nut is a one-time part, it can not be reused. In case it is removed, it should be replaced with a new one.(For IEC 60335-2-40: 2018 only)

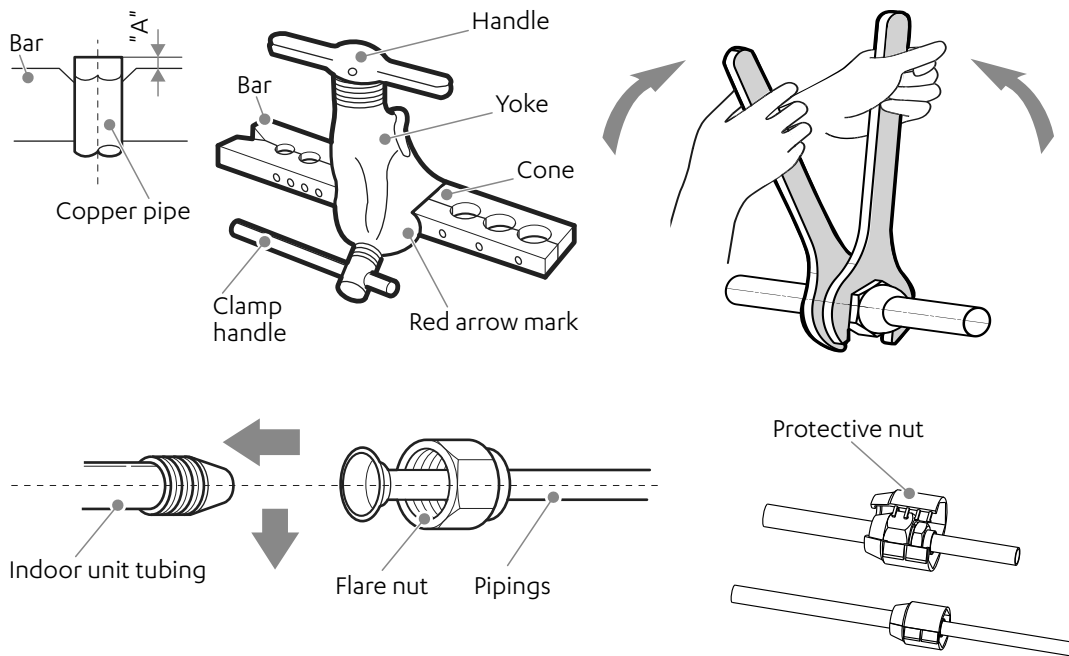

⚠ CAUTION

- Excessive torque can break nut on installation conditions.
- When flared joints are reused indoors, the flare part should be re-fabricated.

Pipe size (mm)	Tightening torque [N.m (kgf.cm)]
Ø6.35	14.2–17.2 (144–176)
Ø9.52	32.7–39.9 (333–407)
Ø12.7	49.5–60.3 (504–616)
Ø15.9	61.8–75.4 (630–770)
Ø19.1	97.2–118.6 (990–1210)

⚠ CAUTION

Depending on the installation conditions, excessive torque will damage the flared mouth, and too small torque cannot tighten the nut, which will cause refrigerant leakage. Please refer to the above table to determine the appropriate tightening torque.

08.05. Refrigerant Piping Fixing

Angle iron brackets or round steel hangers should be used for fixing. When the liquid pipe and gas pipe are suspended together, the size of the liquid pipe shall prevail.

Pipe outer diameter (mm)	≤20	20~40	≥40
Horizontal pipe distance (m)	1.0	1.5	2.0
Stand pipe distance (m)	1.5	2.0	2.5

08.06. Vacuum Pumping

Connect the refrigerant piping to the gas and liquid pipes of the Outdoor Unit, and use a vacuum pump to evacuate the gas and liquid pipes of the Outdoor Unit at the same time.

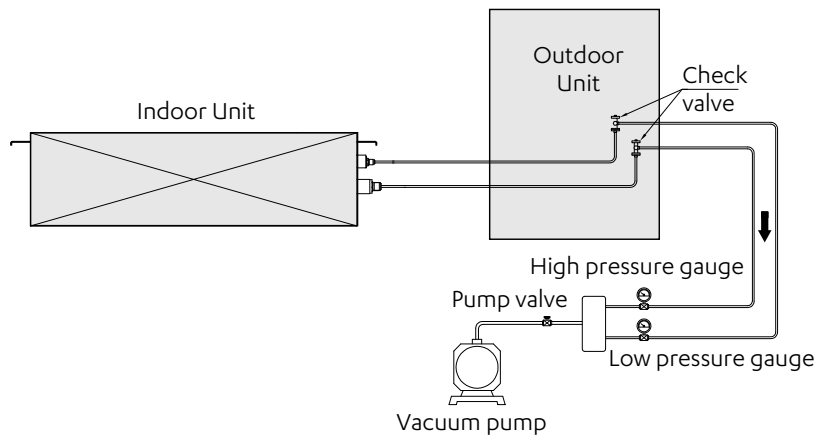

CAUTION

Do not use the refrigerant enclosed in the Outdoor Unit for vacuuming. The reduction of Outdoor Unit refrigerant may cause performance degradation of the air conditioner.

08.06.01. Leak Detection

Fill the system with nitrogen and increase its pressure to detect leaks. The following methods are recommended:

1. By foam

Apply soapy water or foam evenly (spray) on areas where leakage may occur, and observe whether air bubbles appear. If there are no air bubbles, it indicates that the system is airtight.

2. By instrument

Use a refrigerant leak detector to identify leaks. Align the leak detector probe with the part where leakage may occur, and follow the instructions to determine whether there is a leak.

CAUTION

Leak detection will be conducted at each spot for at least 3 minutes. If any leak has been identified, tighten the nut and perform the detection again until no leaks are found. After completing the leak detection, wrap the exposed Indoor Unit pipe joint with insulation material and tie it with a binding tie to prevent condensation and dripping water.

08.06.02. Pump Outlet

Pipes on the liquid and air sides have a low temperature during cooling. Take sufficient insulation measures to prevent condensation.

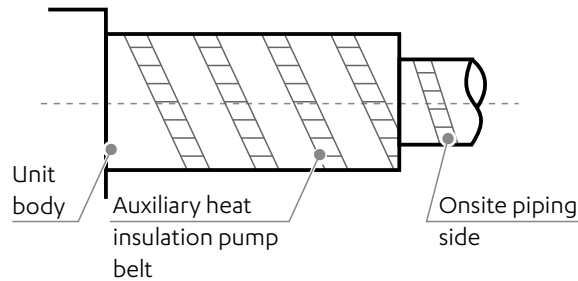
**NOTE**

- Be sure to use a thermal insulation material with a heat resistance of 120°C or higher for the gas pipe.
- The attached insulation material for the part of the Indoor Unit where the pipe connects must undergo heat insulation treatment that leaves no gaps.
- For outdoor pipelines, additional protective treatments should be performed, such as adding metal duct boxes or wrapping the pipes with aluminum foil materials. Thermal insulation materials directly exposed to the open air will degrade and lose their insulating properties

09. Drainage Pipe Installation**⚠ CAUTION**

- Before installation of the condensate pipeline, determine its direction and elevation to avoid intersection with other pipelines to ensure that the slope is smooth and straight.
- The highest point of the drainage pipe should be equipped with a discharge port to ensure the smooth discharge of condensate water, and the discharge port must face downwards to prevent dirt from entering the pipe.
- Do not connect the drainage pipe to the wastewater pipe, sewage pipe, or other pipes that produce corrosive gases or odors. Otherwise, the Indoor Unit (especially the heat exchanger) may be corroded and odor may enter the room, negatively impacting the heat exchange effects and user experience. The user will assume responsibility for any consequences resulting from failure to abide by instructions.
- After the pipeline connection is completed, a water test and a full water test should be done to check whether the drainage is smooth and whether the pipeline system leaks.
- The air conditioner drainage pipe must be installed separately from other sewage pipes, rainwater pipes and drainage pipes in the building.
- Adverse slope, convex and concave pipes are prohibited, as improper airflow will cause poor drainage. Drainage pipes need to be evenly wrapped with thermal insulation pipes to prevent condensation.
- Please connect the drainage pipes in the following ways. Improper installation of the pipes may result in water leakage and damage to furniture and property.
- All joints of the drainage system must be sealed to prevent water leakage.

09.01. Installation of Water Discharge Pipe for the Indoor Unit

Units without pumps: Use the attached drainage hose to connect to the drain pan outlet and PVC pipe, and fasten the two ends of the drainage hose with a cable tie. Then push the thermal insulation pipe to be closely attached to the main body, and finally fasten the end with a cable tie.

Units with pumps: Connect a PVC pipe to the water pump outlet, and fasten it with a cable tie. Then push the thermal insulation pipe until it is closely attached to the main body, and finally fasten the end with a cable tie.

The connection between the two ends of the drainage pipes and the connection of the water pump outlet need to be fastened with a cable tie, in combination with PVC/rubber adhesives. Pay attention to the instructions for the use of the adhesives to prevent corrosion to the EPDM rubber. Use hard PVC adhesives for connecting to other water piping. Check that the connections are tight with no leakage.

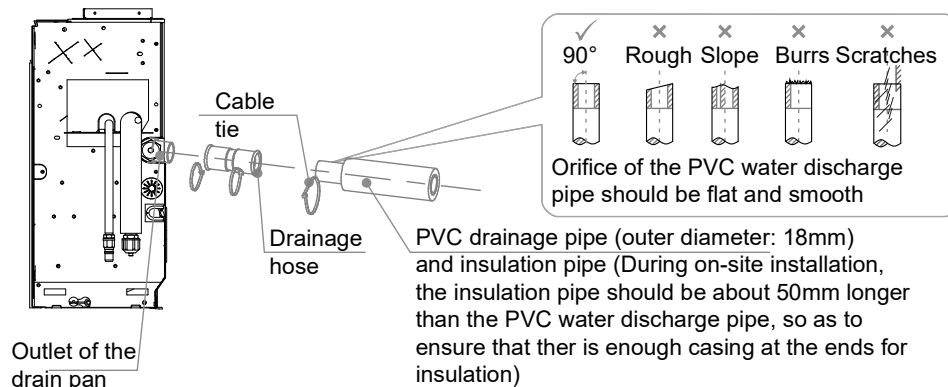

10. Electrical Connection

DANGER

- The power supply must be cut off before any electrical work is carried out. Do not conduct electrical work when the power is on; otherwise, it may cause serious personal injury.
- The air conditioning unit must be grounded reliably and must meet the requirements of the local country/region. If the grounding is not reliable, serious personal injury due to electric leakage may occur.

WARNING

- Installation, inspection or maintenance operations must be completed by professional technicians. All parts and materials must comply with the relevant regulations of the local country/region.
- The air conditioning unit must be equipped with a special power supply, and the power supply voltage should conform to the nominal working voltage range of the air conditioning unit.
- The power supply of the air conditioning unit must be equipped with a power disconnect device that conforms to the requirements of relevant local technical standards for electrical equipment. The power disconnecting device must be equipped with short circuit protection, overload protection and electric leakage protection. The clearance between open contacts of the power disconnecting device shall be at least 3mm.
- The core of the power cable must be made of copper, and the wire diameter should meet the current-carrying requirements. For details, refer to the "Power Cable Diameter and Electric Leakage Protector Selection". A wire diameter that is too small may cause the power cable to heat up, resulting in a fire.
- The power cable and the ground wire should be secured reliably to avoid stress on the terminals. Do not pull the power cable forcibly; otherwise, the wiring may become loosened or the terminal blocks may be damaged.
- Strong current wires such as power cables cannot be connected to weak current wires such as communication lines; otherwise, the product may become seriously damaged.
- Do not bond and connect the power cable. Bonding and connecting the power cable may cause it to heat up, resulting in a fire.

 **CAUTION**

- Bonding and connecting the communication line should be avoided, but if it is used, at the very least, ensure a reliable connection by crimping or soldering and make sure the copper wire at the connection is not exposed; otherwise, communication failure may occur.
- The power cable and communication line must be routed separately, with a distance of over 5 cm. Otherwise, communication failure may occur.
- Keep the vicinity of the air conditioning unit as clean as possible to avoid small animals from nesting and biting the cables. If a small animal touches or bites the cables, short circuiting or electric leakage may occur.
- Do not connect the ground wire to the gas pipe, water pipe, lightning rod ground wire or telephone ground wire. Gas pipe: Risk of explosion and fire when gas leaks.
- Water pipe: If rigid plastic pipes are used, there will be no grounding effect.
- Lightning rod ground wire or telephone ground wire: In the event of lightning strikes, abnormal ground potential may rise.
- After all wiring is completed, check carefully before turning on the power supply.

10.01. Electrical Characteristics

Unit power (kW)	Electric specifications of the Indoor Unit					
	Frequency (Hz)	Voltage (V)	MCA (A)	MFA (A)	IFM Power input (W)	FLA (A)
2.2	50	216~253	0.3	15	100	0.50
2.8			0.3		100	0.50
3.6			0.3		100	0.50
4.5			0.3		100	0.50
5.6			0.4		100	0.60
7.1			0.4		100	0.60
8.0			0.4		100	0.60

NOTES

- MCA: Min. Circuit Amps. (A), which is used to select the minimum circuit size to ensure safe operation over a long period of time.
- MFA: Max. Fuse Amps. (A), which is used to select the circuit breaker.
- IFM power input: full load power input of the indoor fan motor (reliable operation at the fastest speed setting).
- FLA: Full Load Amps. (A), which is the full load current of the indoor fan motor (reliable operation at the fastest speed setting).

10.02. Schematic diagram of the main terminal blocks of main control board

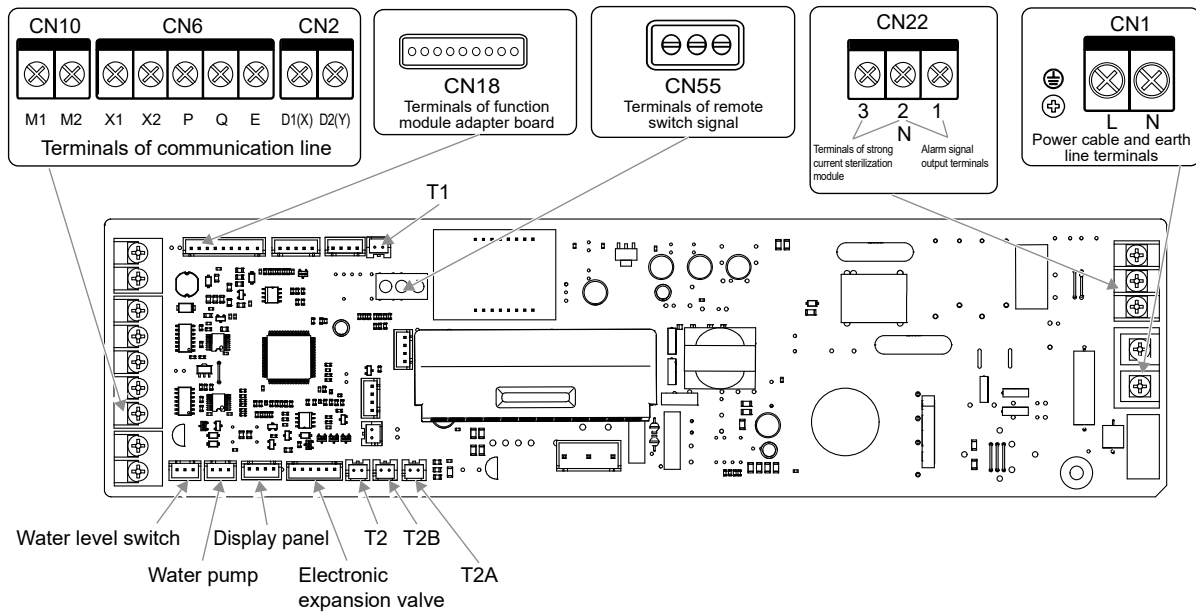

CAUTION



All weak point connection points meet SELV, such as X1, X2, P, Q, E, M1, M2, CN18, CN55 etc

10.03. Wiring

Open the Indoor Unit's electric control box cover

1. Open the Indoor unit's electric control box cover.
2. Remove the two screws at the positions shown in the figure;
3. Pull the bottom end of the electric control box cover horizontally outward;
4. Remove the electric control box cover by pulling downwards.

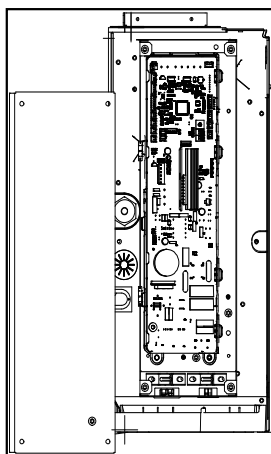

Rated current of appliance (A)			Nominal cross-sectional area (mm ²)					
			Flexible cords			Cable for fixed wiring		
		≤3	0.5	and	0.75	1	to	2.5
>3	and	≤6	0.75	and	1	1	to	2.5
>6	and	≤10	1	and	1.5	1	to	2.5
>10	and	≤16	1.5	and	2.5	1.5	to	4
>16	and	≤25	2.5	and	4	2.5	to	6
>25	and	≤32	4	and	4.6	4	to	10
>32	and	≤50	6	and	10	6	to	16
>50	and	≤63	10	and	16	10	to	25

CAUTION

- The strong and weak current wires must be separated.
- Alarm signal output, strong current sterilization, remote switch, and function expansion board are custom or optional.

10.04. Power cable connection

10.04.01. Connection between the power cable and power supply terminal

The power supply terminal of the Indoor Unit is fixed to the main control board, and the power cable is connected to the power supply terminal labeled "CN1" on the main control board. The live and neutral wires are connected according to the main control board logos "L" and "N", and the ground wire is directly connected to the electric control box sheet metal part.

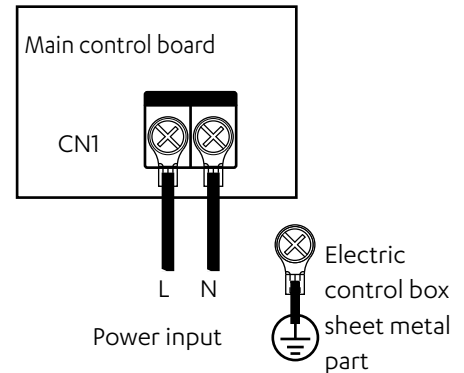

CAUTION

A Do not bond and connect the power cable. Bonding and connecting the power cable may cause it to heat up, resulting in a fire.

The power cable must be crimped reliably using an insulated circular terminal block, and then connected to the power supply terminal of the Indoor Unit, as shown in the figure below.

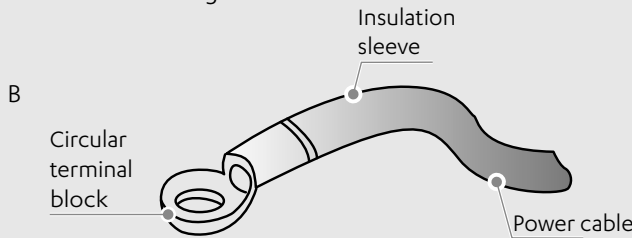

If it fails to crimp the insulated circular terminal block due to on-site limitations, connect the power cables of the same diameter to both sides of the power supply terminal block of the Indoor Unit, as shown in the figure below.

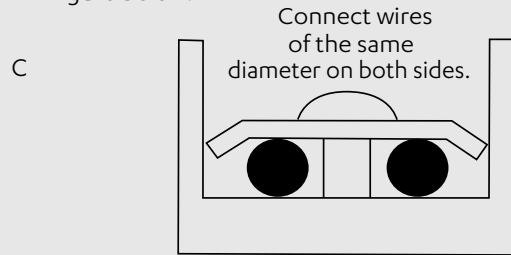

Do not press the power cables of the same wire diameter on the same side of the terminal. Do not use two power cables of different wire diameters for the same terminal blocks; otherwise, they can easily loosen due to uneven pressure and cause accidents, as shown in the figure below.

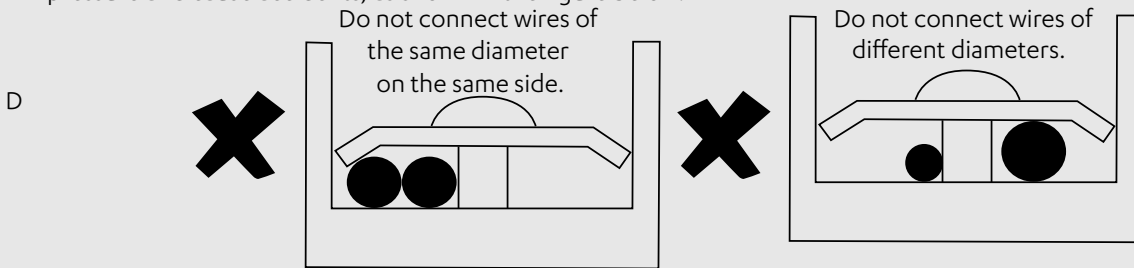

E The connected power cable should be secured with a wire clamp to prevent loosening, as shown in the right figure.

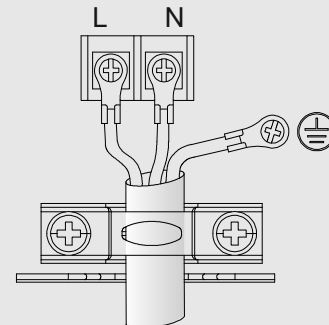

10.04.02. Power cable system connection

Power cable system connection depends on the forms of communication between the Indoor Unit and Outdoor Unit. For the HyperLink communication form with an independent power supply, Indoor Units are allowed to have an independent power supply. For other communication forms, Indoor Units should be provided with uniform power supply.

A. Indoor Units are provided with independent power supplies*, which are wired as follows:

For HyperLink communication with an independent power supply:

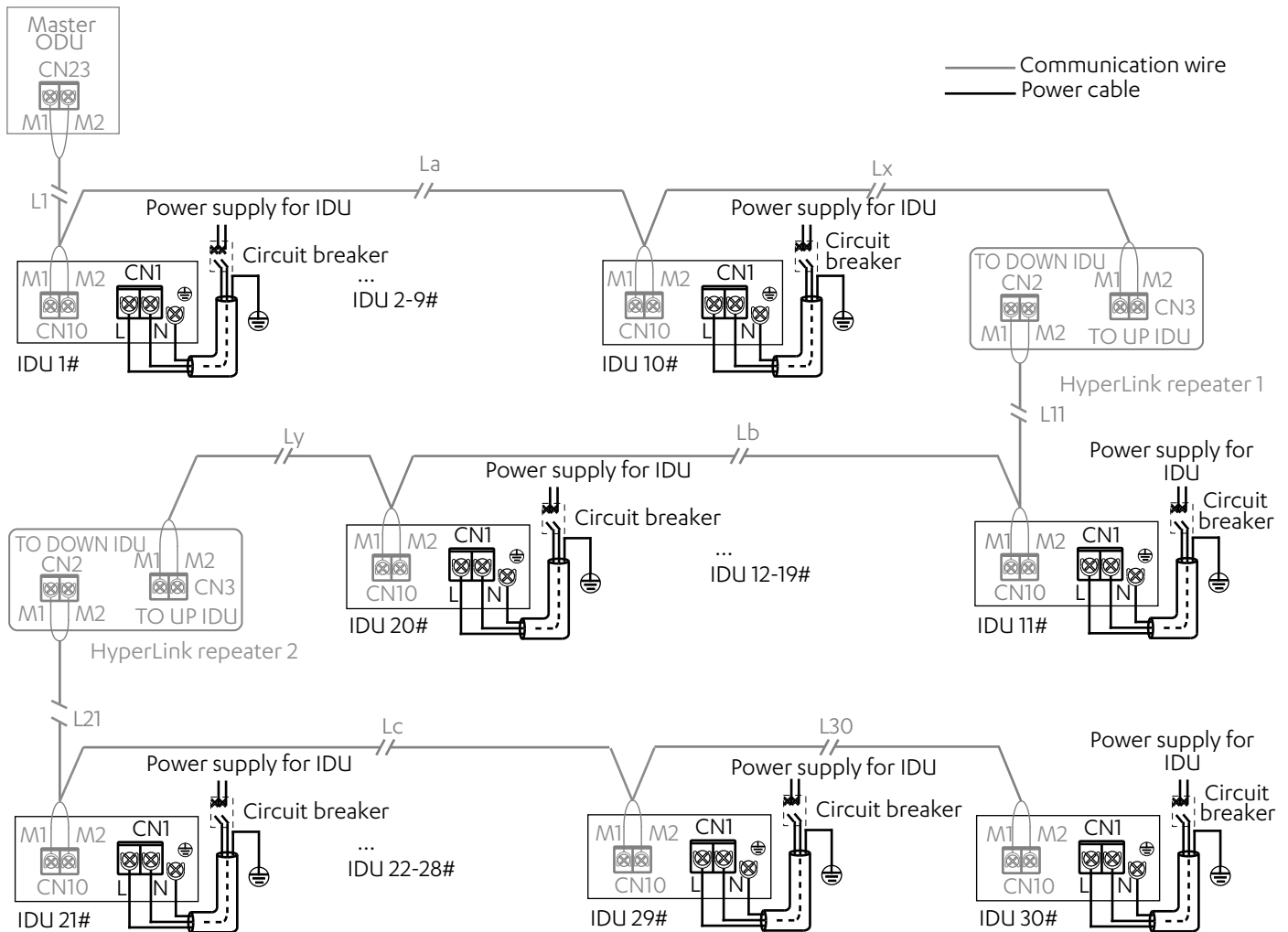

⚠ CAUTION

- When the Indoor Units are provided with independent power supplies, the Indoor Units in the same refrigerant system should be ECOFLEX Indoor Units*, and the communication between Indoor Units and Outdoor Unit adopts a HyperLink with an independent power supply.
- This connection method has the function of an independent power supply, so in the same refrigerant system, the number of Indoor Units must not exceed 30 sets, and a maximum of only two repeaters may be installed*.
- One repeater shall be added for every 10 Indoor Units or a communication distance of 200m added.

B. Indoor Units are provided with uniform power supply*, which are wired as follows:

1. Hyperlink communication with the uniform power supply:

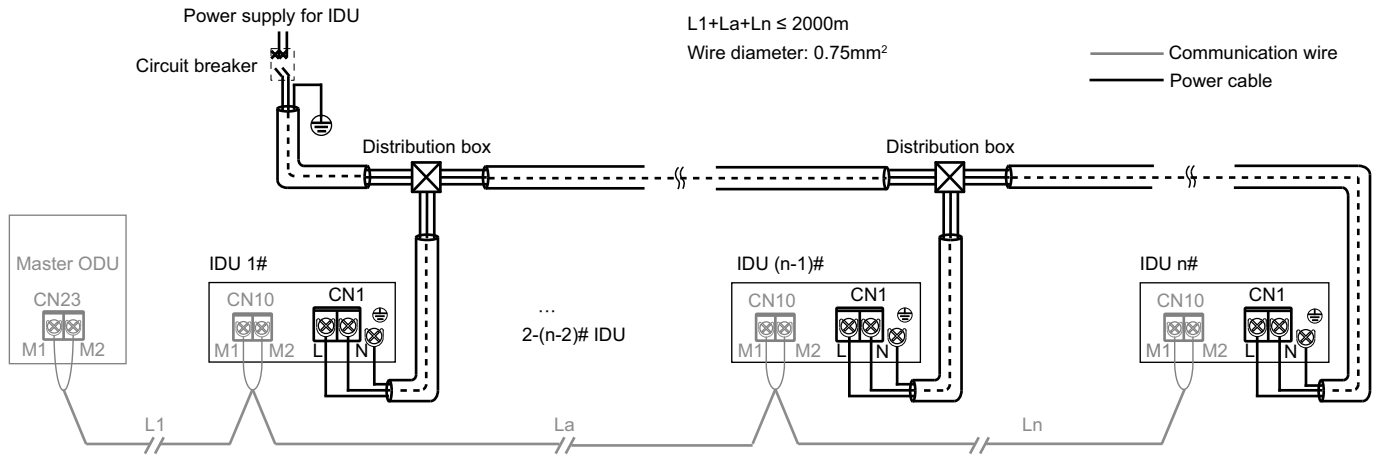

2. P/Q communication:

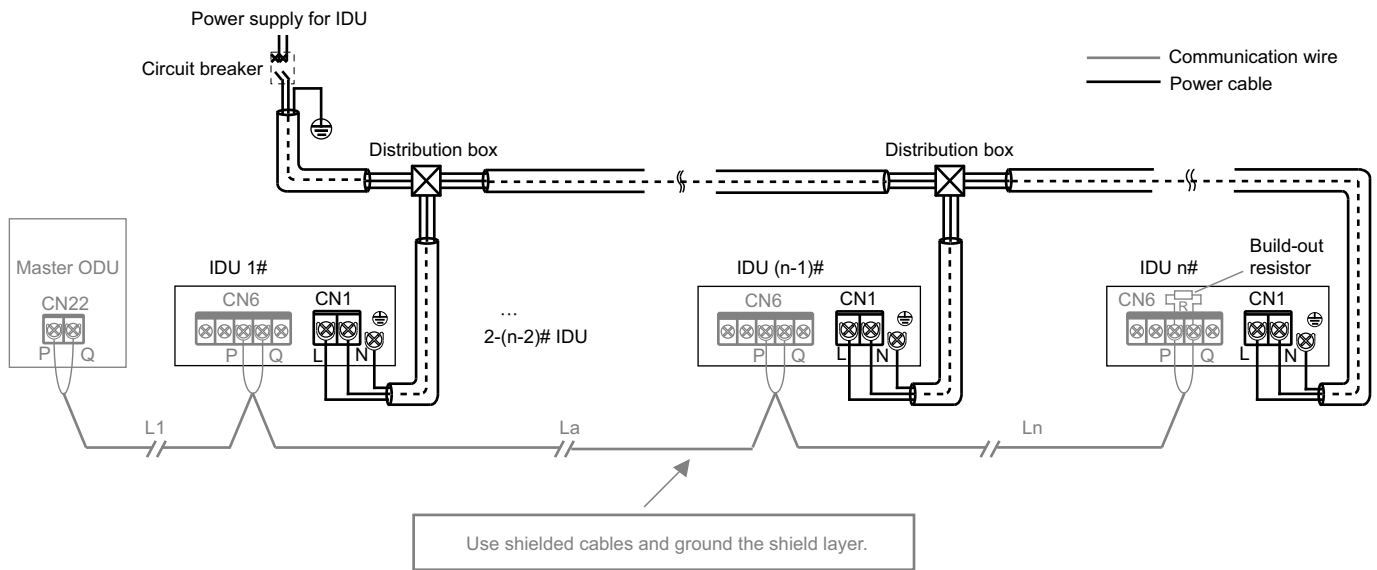

3. P/Q/E communication:

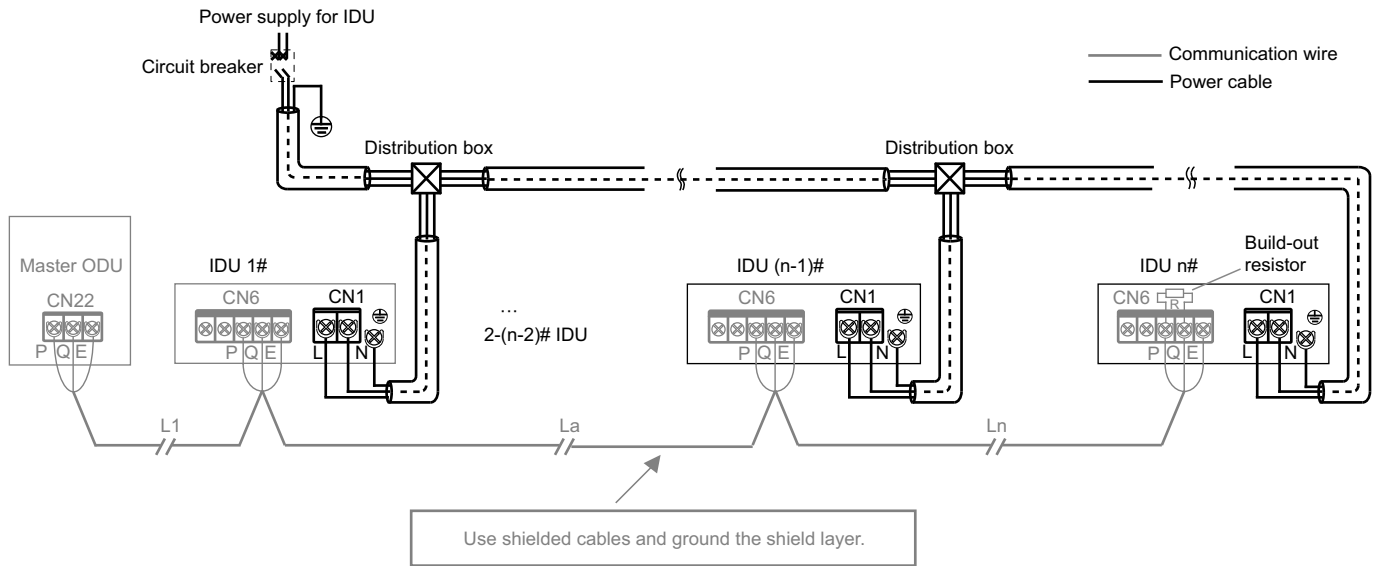

⚠ CAUTION

- When the Indoor Units are provided with a uniform power supply, if the Indoor Units in the same refrigerant system are ECOFLEX Indoor Units, then Indoor Units and Outdoor Unit can communicate either via HyperLink with a uniform power supply, or via P/Q communication. If some of the Indoor Units in the same refrigerant system are non-ECOFLEX series, then Indoor Units and Outdoor Unit can only communicate via P/Q or P/Q/E communication.
- Both P/Q communication and HyperLink communication (M1M2) are indoor and outdoor communication, and only one of them can be selected. Do not connect P/Q communication and HyperLink communication at the same time in the same system. Do not connect HyperLink communication to P/Q or D1D2 communication.

NOTE

- ECOFLEX Indoor Units: with ECOFLEX printed on the packaging carton
- Independent power supply: With separate circuit breakers, the power supply for each Indoor Unit can be controlled independently.
- Uniform power supply: All the Indoor Units in the system are controlled by one circuit breaker.
- Repeater: power supply repeater, which is used to compensate for the pressure drop due to excessive length of line or line resistance when the main control board of the Outdoor Unit provides an independent power supply for Indoor Units through the HyperLink communication line. It is only used in refrigerant systems where Indoor Units are provided with an independent power supply.

10.04.03. Communication line connection

Selection of communication method for Indoor Units

Equipped with independently developed HyperLink (M1M2) communication, ECOFLEX series Indoor Units also preserve the previous RS-485 (PQE) communication method. They are compatible with non-ECOFLEX Indoor Units. Pay attention to the type of Indoor Unit you have purchased before connecting communication lines. Please refer to the following table to select an appropriate communication method.

Indoor Unit type	Optional communication method between Indoor Units and Outdoor Unit	Remarks
When all Indoor Units are ECOFLEX series	HyperLink (M1M2) communication	<ol style="list-style-type: none"> Independent power supply for Indoor Units*. Any topology connection of communication lines. Two-core and non-polar communication for M1M2.
	RS-485 (PQ) communication	<ol style="list-style-type: none"> The Indoor Units need to be powered uniformly. The communication cables must be connected in serial. Two-core and non-polar communication for PQ.
When some Indoor Units are ECOFLEX series	RS-485 (PQE) communication	<ol style="list-style-type: none"> The Indoor Units need to be powered uniformly. The communication cables must be connected in serial. PQE cables must be 3-core and PQ non-polar.

Table of selection of communication line diameter

Function	Indoor Unit and Outdoor Unit communication				One controller to one Indoor Unit (Two controllers to one Indoor Unit) Communication	One-to-more (centralized controller) Communication
	HyperLink communication (Indoor Units are powered independently)	HyperLink communication (Indoor Units are powered uniformly)	P/Q communication (Indoor Units are powered uniformly)	P/Q/E communication (Indoor Units are powered uniformly)	X1X2 communication	D1D2 communication
Wire diameter	2 × 1.5mm ² Wire resistance ≤ 1.33Ω/100m	2 × 0.75mm ²	2 × 0.75mm ² (shielded cable)	3 × 0.75mm ² (shielded cable)	2 × 0.75mm ² (shielded cable)	2 × 0.75mm ² (shielded cable)
Length	≤ 600m (add two repeaters)	≤ 2000m	≤ 1200m	≤ 1200m	≤ 200m	≤ 1200m

CAUTION

- Please select the communication line according to the requirements in the above reference table. Use shielded cables for communication when strong magnetism or interference is present.
- On-site wiring must comply with the relevant regulations of the local country/region and must be completed by professionals.
- Do not connect the communication line when the power is on.
- Do not connect the power cable to the communication terminal; otherwise, the main control board may be damaged.
- The standard value of the screw torque of the communication line terminal is 0.5N·m. Insufficient torque may cause poor contact; excessive torque may damage the screws and power supply terminals.
- Both HyperLink communication and PQ communication are internal and external, so only one of the two can be selected. Do not connect both HyperLink communication line and PQ communication line to the same system, otherwise the Indoor Unit and Outdoor Unit cannot communicate normally.
- If some of the Indoor Units in the same refrigerant system are non-ECOFLEX series, only P/Q/E communication can be selected for the Indoor Unit and Outdoor Unit communication. The three-core shielded cable of 3×0.75mm² is required to connect "P", "Q", and "E".
- Do not bundle the communication line with the refrigerant pipeline, power cable, etc. When the power cable and the communication line are laid in parallel, a distance of more than 5cm should be maintained to prevent interference from the signal source.
- When the construction personnel of the Indoor Unit and Outdoor Unit are working separately, information communication and synchronization are required. Do not connect the Outdoor Unit to HyperLink and the Indoor Unit to PQ. Do not connect the Outdoor Unit to PQ and the Indoor Unit to HyperLink.
- Bonding and connecting the communication line should be avoided, but if it is used, at the very least, ensure a reliable connection by crimping or soldering and make sure the copper wire at the connection is not exposed; otherwise, communication failure may occur.

Indoor Unit and Outdoor Unit communication

1. HyperLink communication (with independent power supply)

Single unit: HyperLink communication is a new type of Indoor Unit and Outdoor Unit communication technology. When the Indoor Units are provided with independent power supplies, use 2×1.5mm² communication cables. M1 and M2 ports are located at terminal block "CN10" of the main control board. There is no distinction between negative and positive electrodes. For details, see the following figure:

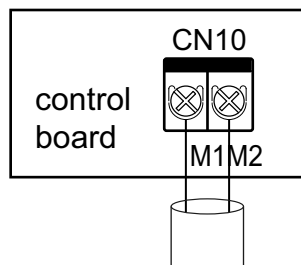

Connect to Outdoor Unit M1M2 (HyperLink)

CAUTION

Do not connect the HyperLink communication line to the PQ or D1D2 communication line.

System: The HyperLink communication line with an independent power supply between the Indoor Unit and Outdoor Unit can reach up to 600 meters, supporting any connection topology. The following figure shows a serial connection:

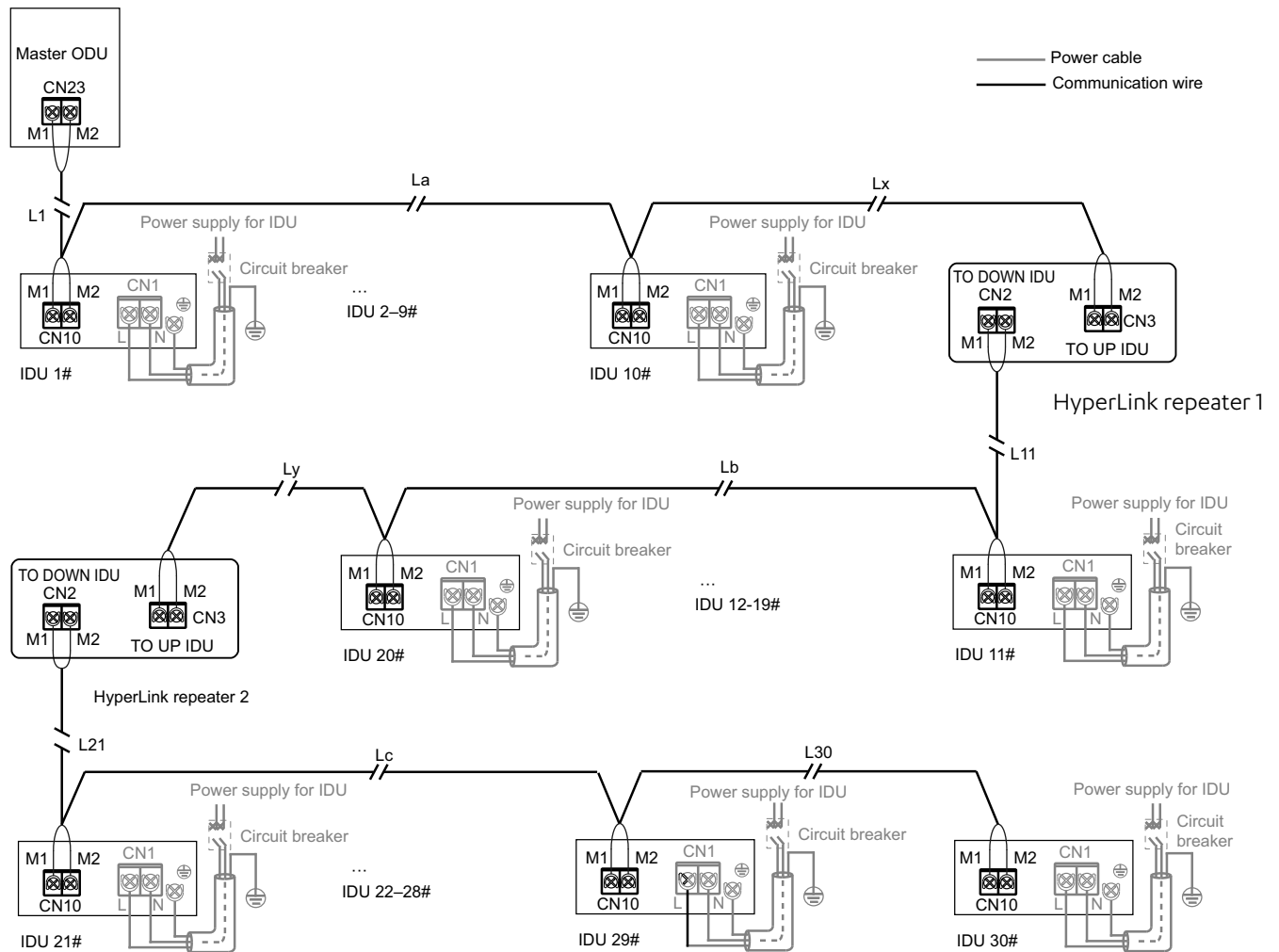

$$L1+La+Lx \leq 200m \quad L11+Lb+Ly \leq 200m \quad L21+Lc+L30 \leq 200m$$

For other connection methods (tree topology, star topology, ring topology), please refer to the technical manual or consult technical personnel.

⚠ CAUTION

- If the total distance is $\leq 200m$ and the total number of Indoor Units is ≤ 10 sets, the valve is powered and controlled by the master Outdoor Unit.
- If the total distance is longer than 200m or the total number of Indoor Units is more than 10 sets, a repeater is required to increase the bus voltage.
- The load capacity of the repeater is the same as that of the Outdoor Unit, and it can load a bus length of 200m or 10 Indoor Units.
- The number of Indoor Units requiring power supply in the same refrigerant system does not exceed 30 sets.
- A maximum of two repeaters can be installed in the same refrigerant system.
- Keep the power on/off for both the repeater and the Outdoor Unit, or use an uninterruptible power supply.
- For repeater installation, refer to the repeater installation manual. Do not connect the upstream and downstream Indoor Unit ports of the repeater in reverse; otherwise, it will cause a communication failure.
- The repeater is optional. If you need to purchase it, please contact your local dealer.

2. HyperLink communication (with uniform power supply)

Single unit: When the Indoor Units are provided with uniform power supply, it is not necessary for HyperLink communication line to provide an independent power supply for Indoor Units. In this case, use 2×0.75mm² communication cables. M1 and M2 ports are located at terminal block "CN10" of the main control board. There is no distinction between negative and positive electrodes. For details, see the following figure:

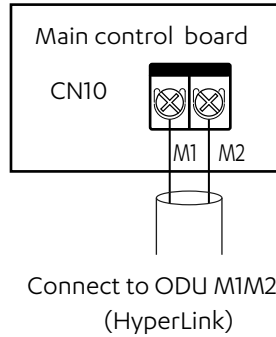

CAUTION

Do not connect the HyperLink communication line to the PQ or D1D2 communication line.

System: The HyperLink communication line with a uniform power supply between Indoor Unit and Outdoor Unit can reach a length of up to 2000 meters, supporting any topology connection. The following figure shows a serial connection:

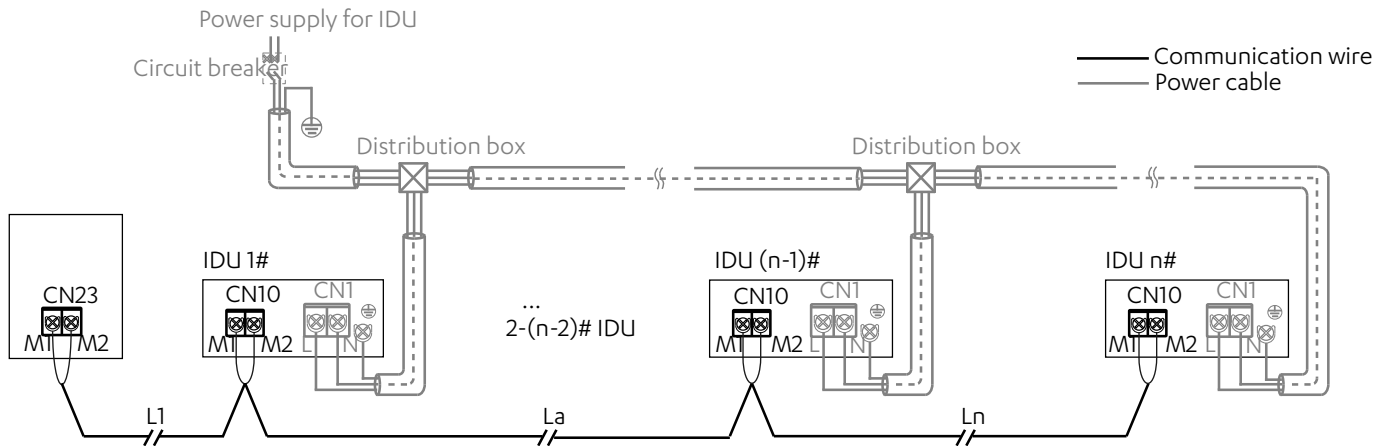

$$L1 + La + Ln \leq 2000m$$

For other connection methods (tree topology, star topology, ring topology), please refer to the technical manual or consult technical personnel

CAUTION

- When HyperLink with a uniform power supply is available, a uniform power supply for IDUs is required.
- For details, see "Power Cable Connection".
- When HyperLink with a uniform power supply is available, there is no need to connect a repeater to the system.

3. P/Q communication

Single unit: Use a shielded cable for the P/Q communication and properly ground the shield layer. P and Q ports are located at terminal block "CN6" of the main control board. There is no distinction between negative and positive electrodes. Connect the shield layer to the sheet metal of the electric control box, as shown in the following figure:

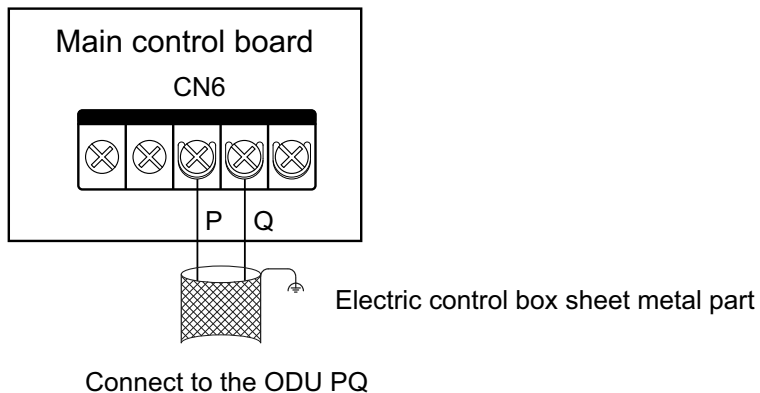

System: The maximum total length of the P/Q communication cable of the IDU and ODU can be up to 1200m, and can be connected in serial, as shown in the figure below:

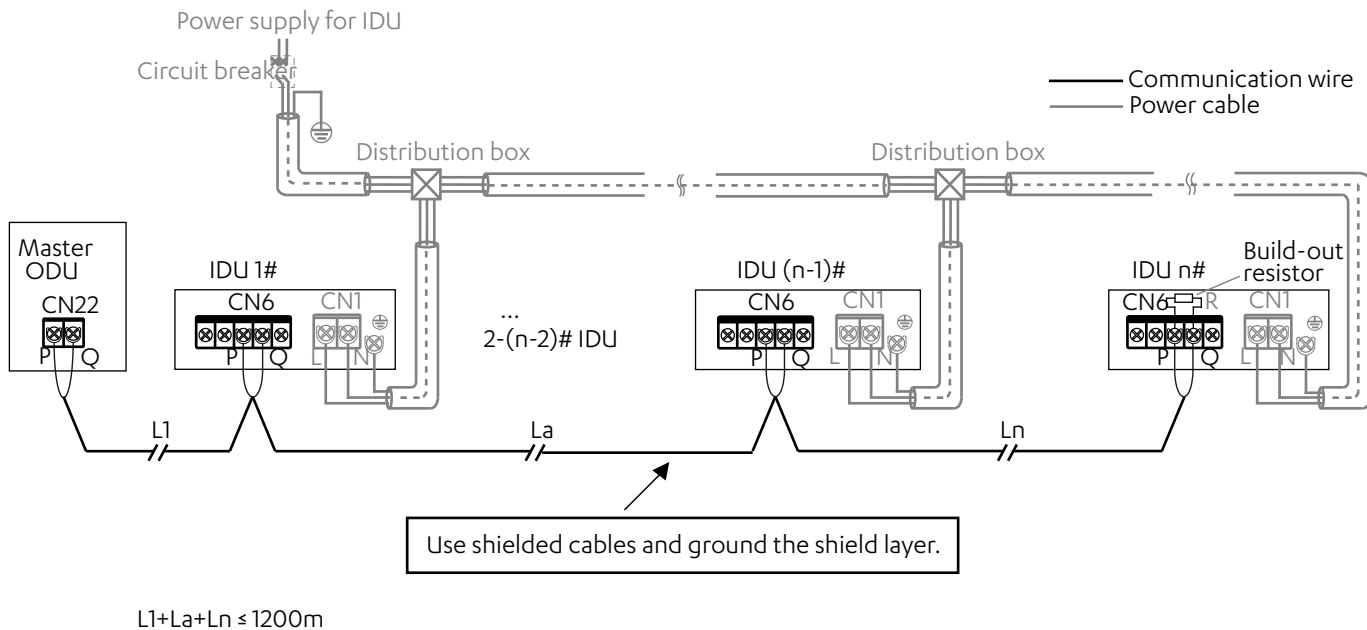

4. P/Q/E communication

If some of the Indoor Units in the same refrigerant system are non-ECOFLEX series, it is required to connect "P", "Q", and "E" for P/Q/E communication.

Single unit: Use a shielded cable for the P/Q/E communication and properly ground the shield layer. P, Q, and E ports are located at terminal block "CN6" of the main control board. There is no distinction between negative and positive electrodes. Connect the shield layer to the sheet metal of the electric control box, as shown in the following figure:

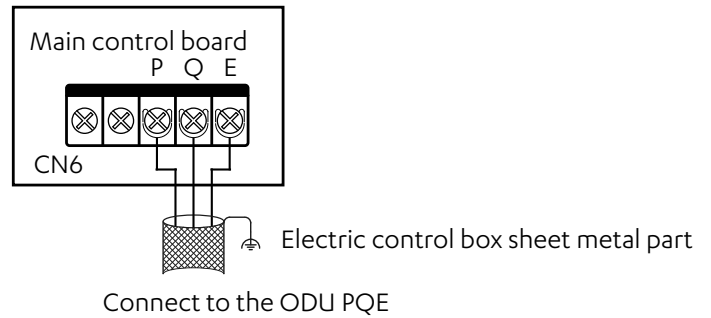

System: The maximum total length of the P/Q/E communication cable of the Indoor Unit and Outdoor Unit can be up to 1200m, and can be connected in serial, as shown in the figure below:

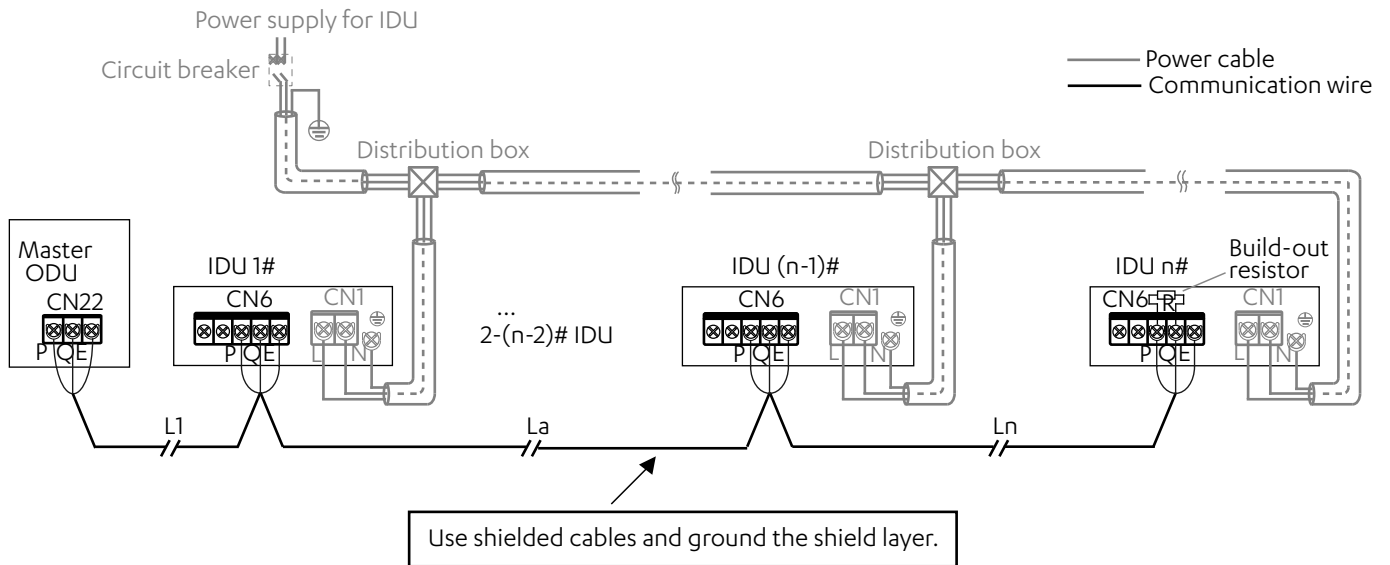

$$L1 + La + Ln \leq 1200m$$

CAUTION

- When P/Q or P/Q/E communication is used, the Indoor Units need to be powered uniformly.
- Either P/Q, P/Q/E communication or HyperLink communication can be selected. If it is required for Indoor Units to have independent power supplies, then HyperLink communication must be selected.
- Use only shielded cables for P/Q or P/Q/E communication. Otherwise, the Indoor Unit and Outdoor Unit communication may be affected.
- A matching resistor needs to be added to the last Indoor Unit on the PQ (in the accessory bag of the Outdoor Unit).

5. X1/X2 communication cable connection

The X1X2 communication line is mainly connected to the wired controller to achieve one controller per Indoor Unit and two controllers per Indoor Unit. The total length of the X1X2 communication line can reach 200 meters. Please use shielded wires, but the shield layer cannot be grounded. X1 and X2 ports are located at terminal block “CN6” of the main control board. There is no distinction between negative and positive electrodes. For details, see the following figure:

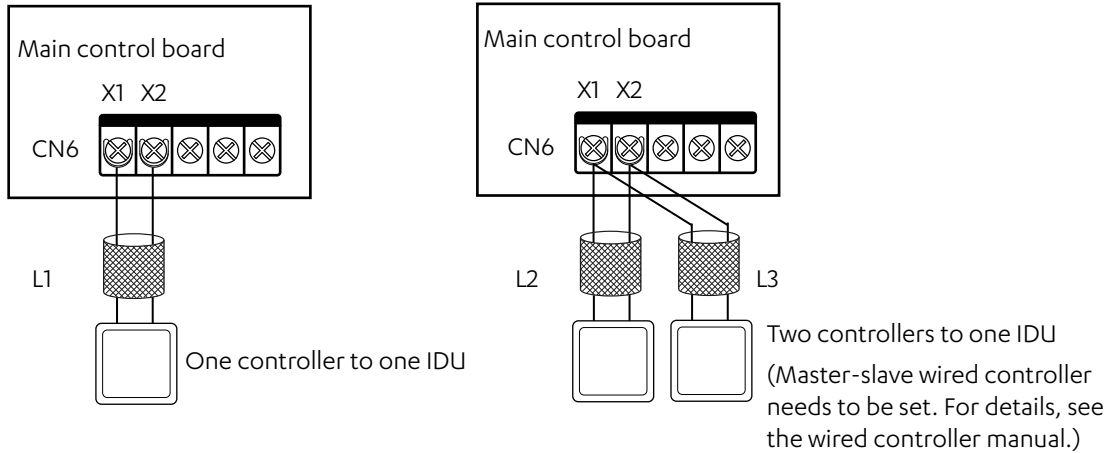

$L1 \leq 200m, L2+L3 \leq 200m$

⚠ CAUTION

Two wired controllers of the same model can be used to control one Indoor Unit at the same time. In this case, you need to set one controller to be the master and the other to be the slave. For details, see the wired controller manual.

6. D1D2 communication line connection (limited to Outdoor Unit and system configuration)

A. Achieving one-to-multiple and two-to-multiple functions of the Indoor Unit wired controller through D1D2 communication (a maximum of 16 sets)

D1D2 communication is 485 communication. The one-to-more and two-to-more functions of the Indoor Unit wired controller can be achieved through D1D2 communication, as shown in the figure below:

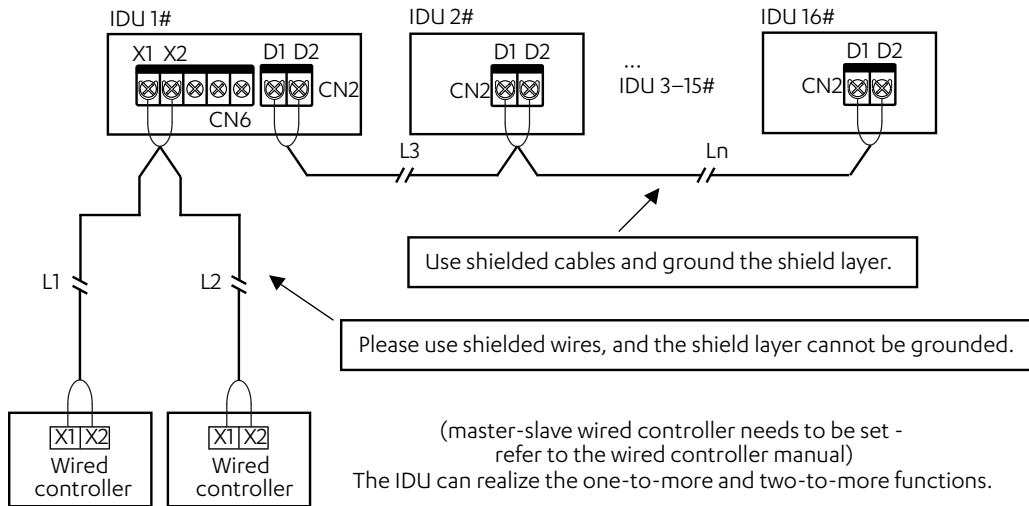

$L1+L2 \leq 200m, L3+Ln \leq 1200m$

CAUTION

- When the Indoor Units in the same refrigerant system are ECOFLEX Indoor Units, D1D2 communication can enable one-to-multiple and two-to-multiple functions of the Indoor Unit wired controller.
- To enable two-to-multiple functions, wired controllers must be of the same model.

B. Achieving centralized control of the Indoor Unit through D1D2 communication

The D1D2 communication line can also be connected to the centralized controller to achieve centralized control of the Indoor Unit, as shown in the figure below:

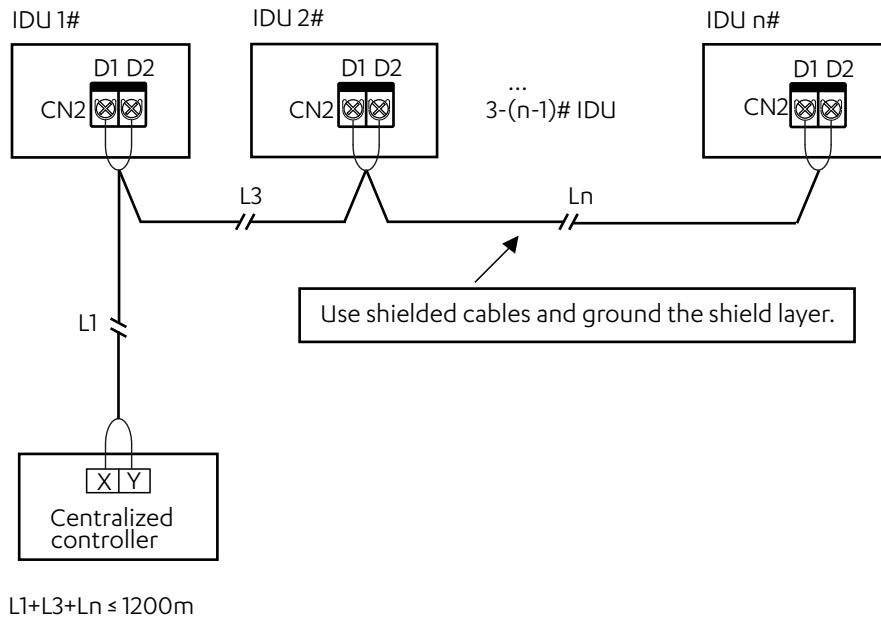

10.04.04. External board connection (limited to Outdoor Unit and system configuration)

The external board is a connection module outside the main control board, including a display panel, a function module adapter board, and 1# and 2# Expansion boards .

Display panel connection

The display panel is connected to the main control board through a 4-core cable, and is connected to the “CN30” socket of the main control board, as shown in the following figure:

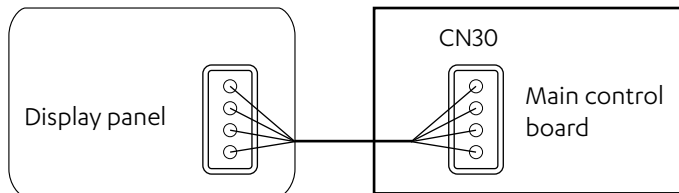

Function module adapter board connection

Function expansion boards can communicate with the main control board through the adapter board. You can use one or both of the two function expansion boards. The wiring diagrams are as follows:

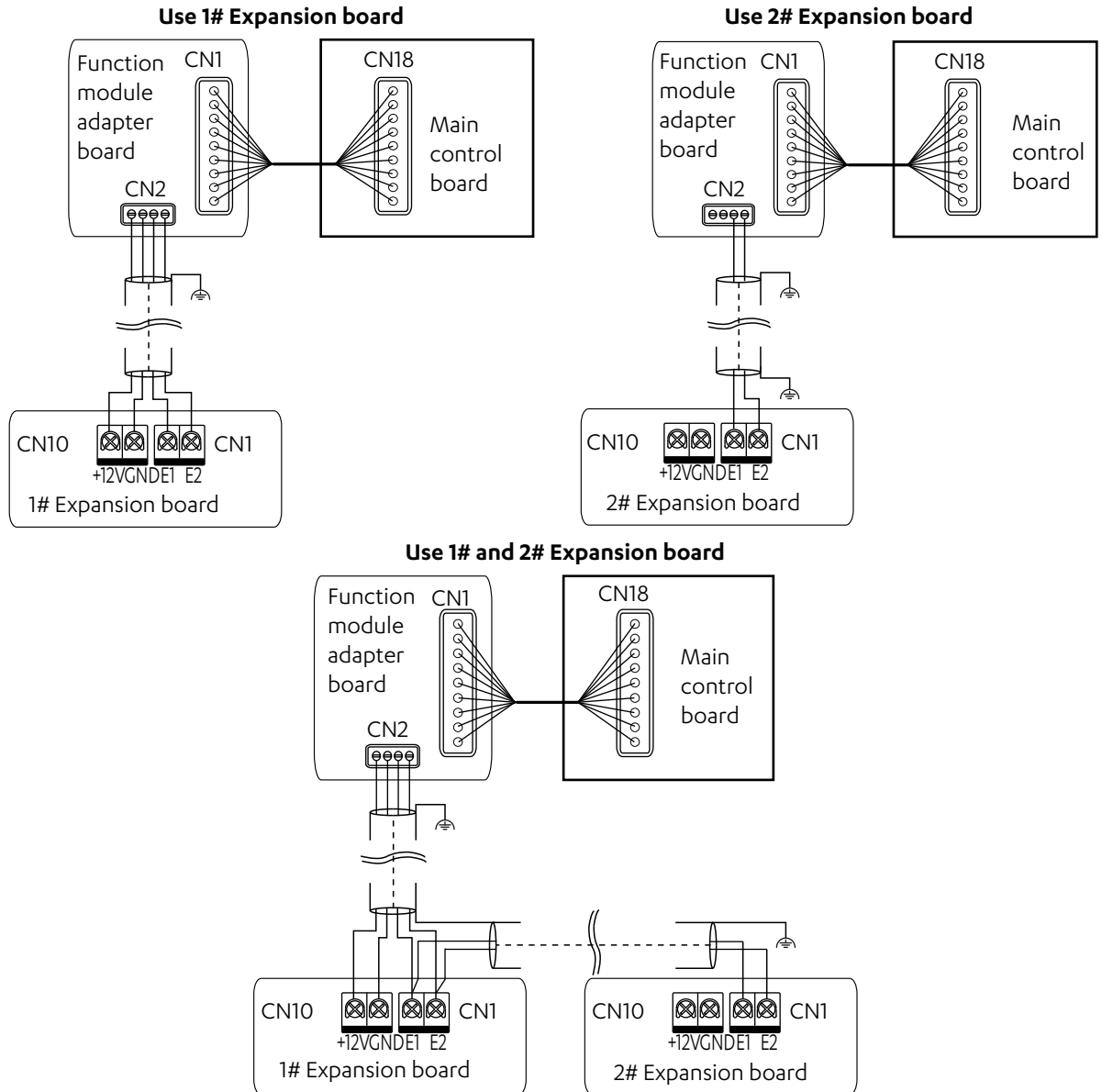

CAUTION

For the function introduction of the function module adapter board, function expansion board 1#, and function expansion board 2#, please refer to the function module manual.

10.04.05. Reclose the electric control box cover

Straighten out the connecting wires and lay them flat, and close the electric control box cover again.

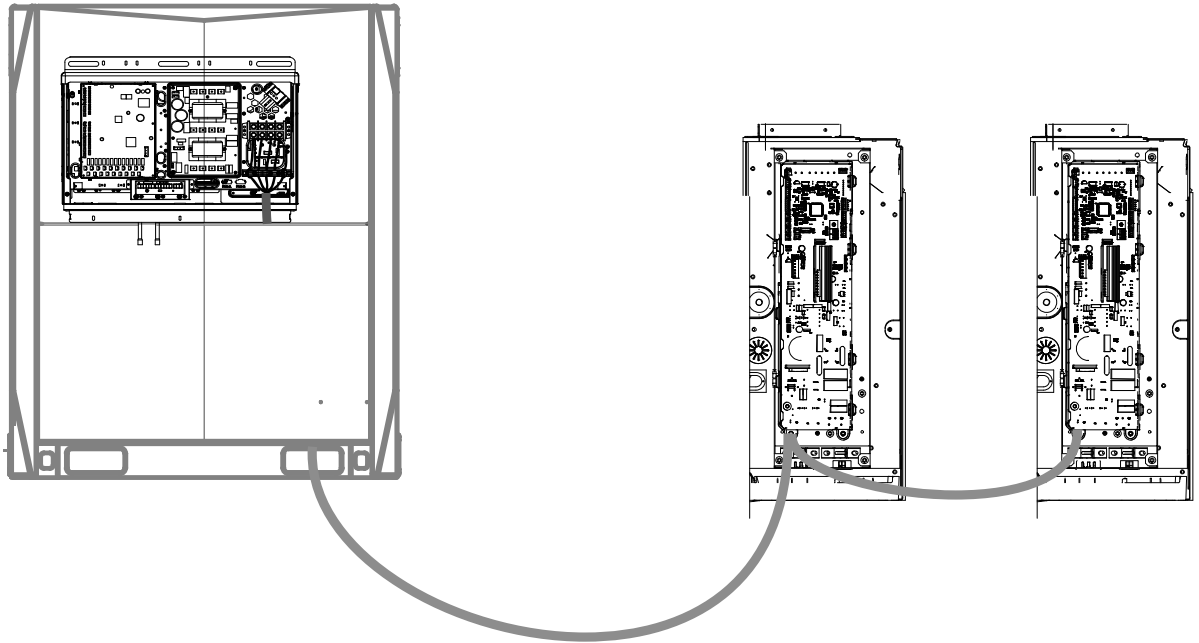
**⚠ WARNING**

Main power supply wiring needs to increase of protective pipe for fixed wiring.

⚠ CAUTION

- Do not cover the electric control box during power-on.
- When covering the electric control box, arrange the cables carefully and do not clip the connecting wires on the electric control box cover

11. Application Control

11.01. Error Codes and Definitions

In the following circumstances (warning failures excluded), please stop the air conditioner immediately, cut off the power switch and contact the local air conditioner customer service center. The error code is displayed on the display panel and the wired controller display.

Error code	Error
A01	Emergency stop
A11	R-32 refrigerant leaks, requiring shutdown immediately
A51	Outdoor Unit fault
A71	The fault of the linked FAPU is transmitted to the master Indoor Unit (series setting)
A72	The fault of the linked humidifying Indoor Unit is transmitted to the master Indoor Unit
A73	The fault of the linked FAPU is transmitted to the master Indoor Unit (non-series setting)
A74	The fault of the AHU Kit slave unit is sent to the master unit
A81	Self-check fault
A82	MS (refrigerant flow direction switching device) fault
A91	Mode conflict (Non-ECOFLEX communication protocol adopted)
b11	1# EEV coil fault
b12	1# EEV body fault
b13	2# EEV coil fault
b14	2# EEV body fault
b34	Stall protection on 1# water pump
b35	Stall protection on 2# water pump
b36	Water level switch alarm
b71	Reheating electric heater fault
b72	Preprocessing electric heater fault
b81	Humidifier fault
C11	Duplicate Indoor Unit address code
C21	Abnormal communication between the Indoor Unit and Outdoor Unit
C41	Abnormal communication between the Indoor Unit main control board and fan drive board
C51	Abnormal communication between the Indoor Unit and wired controller
C52	Abnormal communication between the Indoor Unit and Wi-Fi Kit
C61	Abnormal communication between the Indoor Unit main control board and display board
C71	Abnormal communication between the AHU Kit slave unit and master unit
C72	Number of AHU Kits is not the same as the set number
C73	Abnormal communication between the linked humidifying Indoor Unit and master Indoor Unit
C74	Abnormal communication between the linked FAPU and master Indoor Unit (series setting)
C75	Abnormal communication between the linked FAPU and master Indoor Unit (non-series setting)
C76	Abnormal communication between the main wired controller and secondary wired controller

Error code	Error
C77	Abnormal communication between the Indoor Unit main control board and 1# function expansion board
C78	Abnormal communication between the Indoor Unit main control board and 2# function expansion board
C79	Abnormal communication between the Indoor Unit main control board and adapter board
d16	Air inlet temperature of the Indoor Unit is too low in heating mode
d17	Air inlet temperature of the Indoor Unit is too high in cooling mode
d81	Alarm for exceeding temperature and humidity range
dE1	Sensor control board fault
dE2	PM2.5 sensor fault
dE3	CO2 sensor fault
dE4	Formaldehyde sensor fault
dE5	INTELLECTUAL EYE sensor fault
E21	T0 (fresh inlet air temperature sensor) short-circuits or cuts off
E22	The upper dry bulb temperature sensor short-circuits or cuts off
E23	The lower dry bulb temperature sensor short-circuits or cuts off
E24	T1 (Indoor Unit return air temperature sensor) short-circuits or cuts off
E31	The built-in room temperature sensor of the wired controller short-circuits or cuts off
E32	The wireless temperature sensor short-circuits or cuts off
E33	The external room temperature sensor short-circuits or cuts off
E61	Tcp (pre-cooled fresh air temperature sensor) short-circuits or cuts off
E62	Tph (pre-heated fresh air temperature sensor) short-circuits or cuts off
E81	TA (outlet air temperature sensor) short-circuits or cuts off
EA1	Outlet air humidity sensor fault
EA2	Return air humidity sensor fault
EA3	Upper wet bulb sensor fault
EA4	Lower wet bulb sensor fault
EC1	R-32 refrigerant leakage sensor fault
F01	T2A (heat exchanger inlet temperature sensor) short-circuits or cuts off
F11	T2 (heat exchanger middle temperature sensor) short-circuits or cuts off
F12	T2 (heat exchanger middle temperature sensor) overtemperature protection
F21	T2B (heat exchanger outlet temperature sensor) short-circuits or cuts off
P71	Main control board EEPROM fault
P72	Indoor Unit display control board EEPROM fault
U01	Locked (electronic lock)
U11	Unit model code not set
U12	Horsepower code not set
U14	Horsepower code setting error
U15	AHU Kit fan control input signal DIP setting error

Error code	Error
U38	Address code not detected
J01	Motor failed more than once
J1E	IPM (fan module) overcurrent protection
J11	Instantaneous overcurrent protection for phase current
J3E	Low bus voltage fault
J31	High bus voltage fault
J43	Phase current sample bias error
J45	Motor and Indoor Unit are unmatched
J47	IPM and Indoor Unit are unmatched
J5E	Motor startup failure
J52	Motor blocking protection
J55	Speed control mode setting error
J6E	Phase lack protection of motor

11.02. Operating Status Codes and Definitions (Non-Error)

Code	Definition
d0	Oil return or preheating operation
dC	Self-cleaning
dd	Mode conflict (ECOFLEX communication protocol adopted)
dF	Defrosting
d51	Static pressure detection
d61	Remote shutdown
d71	Indoor Unit backup operation
d72	Outdoor Unit backup operation
OTA	Main control program upgrading



CAUTION

- Error codes are displayed only for certain Outdoor Unit models and Indoor Unit configurations (including the wired controller and display panel).
- When the main control program is being upgraded, make sure that the Indoor Unit and Outdoor Unit remain powered on. Otherwise, the upgrading process will stop.

11.03. Spot Check Description

Use the bi-directional communication wired controller (for example, WDC3-86S) to activate the spot check function in the following steps:

1. On the main page, hold "≡" and "∧" for 2s to enter the query page. The Outdoor Unit displays u00-u03, the Indoor Unit displays n00-n63 (the last two digits show the Indoor Unit address), and the wired controller displays CC. Press the "∧" or "∨" key to select the Indoor Unit, and press the "↵" key to enter the parameter query page.
2. Press the "∧" or "∨" key to query the parameters, and the parameters can be queried cyclically. See the spot check list below for details.
3. Press the "⌚" key to exit the query function.
4. On the top of the query page, the "Timing area" displays the spot check serial number, and the "Temperature area" displays the content of the spot check parameters.

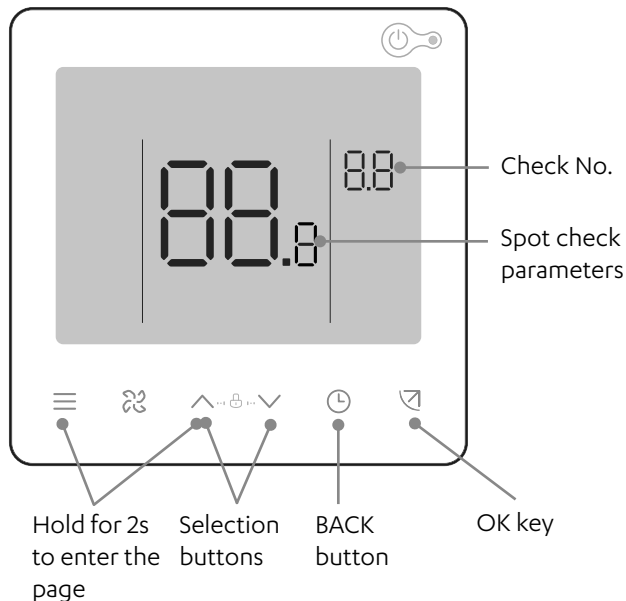

No.	Displayed content	No.	Displayed content
1	Indoor Unit and Outdoor Unit communication address (current Indoor Unit addresses are displayed every 0.5s)	13	Compressor discharge temperature
2	Capacity HP of Indoor Unit	14	Target overheating
3	Actual set temperature Ts	15	EEV opening (actual opening/8)
4	Current running set temperature Ts	16	Software version No.
5	Actual T1 indoor temperature	17	Display board version No.
6	Modified indoor temperature T1_modify	18	Fan drive version No.
7	T2 heat exchanger intermediate temperature	19	Historical error code (recent)
8	T2A heat exchanger liquid pipe temperature	20	Historical error code (sub-recent)
9	T2B heat exchanger gas pipe temperature	21	Indoor Unit network address display
10	Actual set humidity RHs	22	Indoor Unit expansion board address display
11	Actual RH indoor humidity	23	[— — —] is displayed
12	Real-time static pressure		

11.04. ESP Setting

Use the bi-directional communication wired controller (for example, WDC3-86S) to set the unit external static pressure, which can be divided into the following two situations:

Constant speed mode

The bi-directional communication wired controller must be used to set the unit external static pressure parameters to overcome the air outlet resistance. The steps are as follows:

1. On the main page, hold “≡” and “↖” for 3s. The Outdoor Unit displays u00-u03, while the Indoor Unit displays n00-n63 (the last two digits show the Indoor Unit address). The wired controller displays “CC”. Press the “^” or “v” key to select the Indoor Unit address, and press the “↖” key to enter the parameter setting page. The wired controller displays “n00”.
2. On the parameter setting page, the wired controller displays “n00”. Press the “↖” key to enter the specific parameter setting, and then press “^” and “v” to adjust the parameter value of the unit external static pressure. Then, press the “↖” key to save the parameters. The unit external static pressure parameter has now been set.
3. Press “⌚” to return to the previous page until exiting the parameter settings or perform no operations for 60s and the system will automatically exit the parameter settings.

Parameter code	Parameter name	Parameter range	Default value	Remarks
n00	Unit external static pressure	Unit external static pressure: 01/02/03/04/05/~ /19	1.5-8.0kW: 02	Set the corresponding static pressure value FF of the Indoor Unit according to the Indoor Unit speed

Static pressure setting parameter table (covered product)

Unit power		Static pressure settings						
W*100		Level 02	Level 04	Level 06	Level 07	Level 08	Level 09	Level 10
KW	HP	Pa	Pa	Pa	Pa	Pa	Pa	Pa
2.2	22 (0.8HP)	0	10	20	30	40	50	60
2.8	28 (1.0HP)							
3.6	36 (1.2HP)							
4.5	45 (1.7HP)							
5.6	56 (2.0HP)							
7.1	71 (2.5HP)							
8.0	80 (3.0HP)							

Static pressure setting parameter table (covered product)

Unit power		Static pressure settings						
W*100		Level 02	Level 04	Level 06	Level 07	Level 08	Level 09	Level 10
KW	HP	Pa	Pa	Pa	Pa	Pa	Pa	Pa
2.2	22 (0.8HP)	0	10	10	10	10	10	10
2.8	28 (1.0HP)							
3.6	36 (1.2HP)							
4.5	45 (1.7HP)							
5.6	56 (2.0HP)							
7.1	71 (2.5HP)							
8.0	80 (3.0HP)							

 **CAUTION**

- Parameters can be set while the unit is powered on or powered off.
- On the parameter setting page, the wired controller does not respond to a remote signal, and does not respond to the app remote control signal.
- When it is in the parameter settings page, the mode, fan speed, and switch buttons are invalid. Please refer to the remote controller manual for the setting parameters of the remote controller. For other Indoor Unit parameter settings, please refer to the manual of the wired controller.

12. Test Run

12.01. Before the Test Run, Make Sure That

- Indoor Units and the Outdoor Unit are properly installed.
- The piping is correct, and the refrigerant piping system has been checked for leakage.
- Piping length and the amount of refrigerant charged have been recorded.
- The wiring is correct and firm without virtual connection issues. Ground wires have been properly connected.
- The voltage of the power supply is the same as the rated voltage of the air conditioner.
- Heat insulation is complete.
- There are no obstructions at the air inlet and outlet of the Indoor Unit and Outdoor Unit.
- Fully open the check valves of the gas pipe and liquid pipe of the Outdoor Unit.
- Turn on the power supply to preheat the Outdoor Unit for 12 hours.

12.02. Test Run

- Use the wired/remote controller to control the cooling or heating operation of the air conditioner according to the instructions.
- In the event of a failure, please troubleshoot according to the “Symptoms That Are Not Faults” in the “Precautions for Use” in this manual.

 **CAUTION**

Follow the trial run steps of the Outdoor Unit

12.03. Indoor Unit

- The wired/remote controller switch is operating normally.
- The display of the wired/remote controller is normal, the function keys work normally, the room temperature adjustment is normal, and the air flow and direction adjustment are normal.
- The LED indicator is on.
- Water discharge is normal.
- Check the Indoor Units one by one for normal operation, and the cooling and heating functions are normal without vibration or abnormal sound.

12.04. Outdoor Unit

- There are no vibrations or strange sounds during operation.
- The fan, noise and condensation do not affect the neighbors.
- There is no refrigerant leakage.

12.05. Inspection After Installation

To ensure a comfortable indoor environment, please run down through the list to check whether the installation of the air conditioner meets the requirements. Insert a “X” for Fail and a “✓” for Pass.

Check Item	Check Criteria	Check Result (Pass/Fail)
Are the Indoor Units and Outdoor Units securely installed?	The air conditioner does not fall or vibrate, and there is no noise.	
Has the installation of the Indoor Unit been completed?	The unit works properly and no parts are burned out.	
Has a leak test been performed?	The cold/hot air is sufficient.	
Is the heat insulation in good condition (refrigerant piping, drainage pipe, and air ducts)?	There is no condensation dripping.	
Were the copper pipes sealed before installation to prevent dust from entering?	The compressor is functional.	
Is the refrigerant piping filled with nitrogen for shielded welding during the welding process (a nitrogen cylinder is on site)?	There is no oxide film on the inner surface of the copper pipe. The system is functional with no major failures.	
Has a water discharge test been performed? Is drainage smooth? Is the connection secure?	There is no water leakage.	
Is the power supply voltage consistent with the specified voltage on the unit nameplate?	The unit works properly and no parts are burned out.	
Are the wires and pipes connected correctly?	The unit works properly and no parts are burned out.	
Is the air conditioner safely grounded?	There is no electric leakage.	
Have wires of the specified size been used?	The unit works properly and no parts are burned out.	
Are the terminal screws securely fastened?	There is no electric shock or fire.	
Are the inlets and outlets of the Indoor Units and Outdoor Units free of obstruction?	The cold/hot air is sufficient.	
Has the unit's external static pressure been set for the Indoor Unit in constant speed mode?	The cooling and heating functions are normal.	
Has the refrigerant piping length and refrigerant charge been recorded?	The amount of refrigerant in the air conditioning system is clear.	
Was an access hole reserved at the installation position of the Indoor Unit?	The maintenance can be easily carried out.	
Are air filters and grilles installed (at air inlets and outlets)?	The unit works properly.	
Does the temperature of each room meet the requirements during testing?	Users' comfort needs can be satisfied.	
Have you explained to the user how to operate the unit according to the user manual?	The unit is effective.	
Have you explained to the user how to operate and clean the air filter, grille (air inlets and outlets), etc.?	The unit is effective.	

THIS PAGE WAS INTENTIONALLY LEFT BLANK



actronair.com.au

1300 522 722



©Copyright 2023 Actron Engineering Pty Limited ABN 34 002767240. ®Registered Trade Marks of Actron Engineering Pty Limited. ActronAir is constantly seeking ways to improve the design of its products. Therefore, specifications are subject to change without notice.