

# PACKAGE UNIT

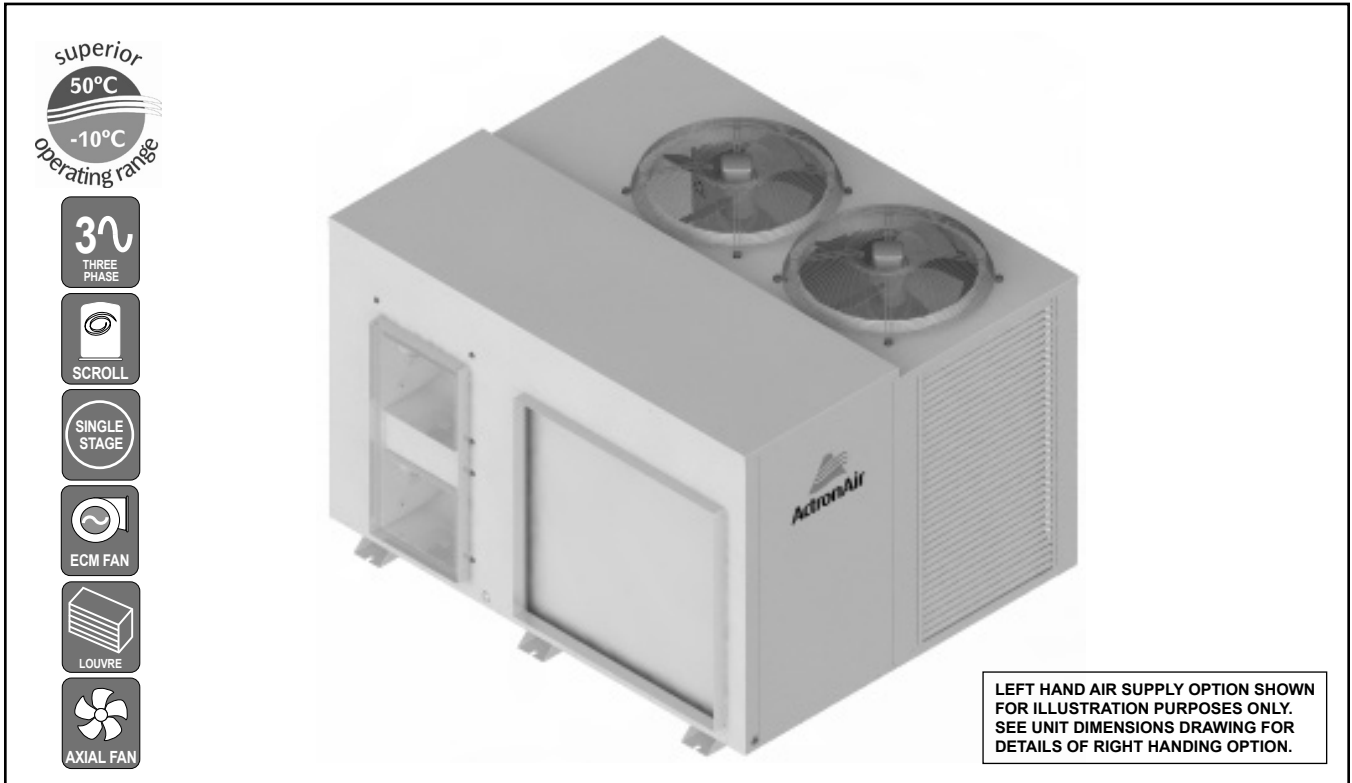

3 Phase  
1 Stage  
29.50 kW

## UNIT FEATURES

- Compliant Scroll Compressors
- Full Factory Charged with R410A Refrigerant
- Multiple Speed Outdoor Fans
- Blue Epoxy Coat Coil Fin Protection - Indoor & Outdoor Coils
- Louvred Outdoor Coil Guard
- Adaptive Demand Defrost
- EC Variable Speed Indoor Fan
- Adjustable Dial-Up Indoor Airflow

## UNIT OPTIONS

- Low Ambient
- Compressor Soft Starters
- Phase Protection
- Additional Full Coil Coat Protection
- Fault Detection Board

## CONTROL OPTIONS & FEATURES

### ActronAir C7-4 (BCA Compliant)

- 7-Day Programmable Controller with 2 Events/Day
- Temperature Set Back and After Hours Timer
- Auto, Heat & Cool Modes
- Auto/Continuous Indoor Fan Operation
- 1 Speed Indoor Fan Setting
- Hot Start Feature
- 2 Stage Cooling/Heating with 3rd Stage Boost Heat
- Manual Control Inputs
- Remote Temperature Sensors
- 24-Hour ON/OFF Timer
- Home/Building Automation ON/OFF Capability

## UNIT COMPLIANCE

- MEPS 2012 / GEMS 2012
- AS/NZS 4755.3.1 Demand Response Capabilities
- AS/NZS 60335.1 Electrical Appliance Safety
- AS/NZS CISPR 11:2011 (Group 1 ClassA) EMC Compliance

## SPECIFICATION SUMMARY

PACKAGE UNIT MODEL	PCG290L/R	
	(1) TOTAL	(2) NETT
(3) COOLING CAPACITY (kW)	29.50	28.30
(3) SENSIBLE CAPACITY (kW)	25.43	24.23
(4) HEATING CAPACITY (kW)	27.40	28.60
(5) COOLING INPUT POWER (kW)	8.45	
(5) HEATING INPUT POWER (kW)	7.97	
EER	3.49	3.35
COP	3.44	3.59
(6) INDOOR AIRFLOW (l/s) - MIN. / NOMINAL / MAX.	1275 / 1500 / 1650	
OUTDOOR SOUND PRESS. LEVEL @ 3M dB(A) - LOW / HIGH	56.9 / 60.9	
OUTDOOR SOUND POWER LEVEL dB(A) - LOW / HIGH	73.9 / 77.9	
POWER SUPPLY	400V / 3Ph+N / 50Hz	
(2) RATED LOAD AMPS	24.5	
(7) FULL LOAD AMPS	30.9	
(8) CIRCUIT BREAKER AND CABLE AMPS	32.0	
APPROXIMATE STARTING AMPS	111.0	
WEIGHT (kg)	450	

(1) Based on unit rating excluding indoor fan kW.  
 (2) Measured and tested in accordance with AS/NZS 3823.1.2.  
 (3) At 27°C DB / 19°C WB entering air temperatures and 35°C ambient.  
 (4) At 20°C DB entering air temperature and 7°C DB / 6°C WB ambient.  
 (5) input power includes indoor fan kW.  
 (6) Max. - Min. airflow application range.  
 (7) Full Load Amps are based on compressor and fan motors' maximum expected current.  
 (8) See Specifications sheet for cable size and circuit breaker size details.

Note: Use input power to estimate running cost.



# CAPACITY SELECTION DATA

# PCG290L/R

## COOLING PERFORMANCE

AIR ENTERING		TOTAL CAPACITY kW	TOTAL SENSIBLE CAPACITY - kW										
OUTDOOR DB - °C	INDOOR WB - °C		AT DB TEMPERATURE ONTO INDOOR COIL - °C										
			20	21	22	23	24	25	26	27	28	29	30
25	16	29.88	20.27	22.01	23.48	25.14	26.73	28.30	29.64				
	17	30.55	18.47	20.23	21.99	23.44	25.13	26.77	28.31	29.78	31.02		
	18	31.41	16.67	18.42	20.17	21.92	23.67	25.09	26.72	28.30	29.79	31.23	
	19	32.30	14.80	16.60	18.38	20.12	21.85	23.57	25.00	26.67	28.28	29.83	31.27
	20	33.16	12.95	14.76	16.51	18.31	20.03	21.78	23.49	24.93	26.61	28.23	29.82
	21	34.07		12.86	14.66	16.47	18.22	19.96	21.70	23.44	24.84	26.56	28.20
	22	35.10			12.79	14.57	16.36	18.13	19.90	21.62	23.35	25.09	26.45
30	16	28.86	19.69	21.42	22.88	24.54	26.15	27.64	28.84				
	17	29.40	17.91	19.64	21.38	22.86	24.53	26.16	27.71	29.12			
	18	30.14	16.08	17.84	19.59	21.33	22.79	24.47	26.12	27.70	29.16	30.48	
	19	30.97	14.25	16.04	17.79	19.55	21.27	23.00	24.41	26.08	27.69	29.22	30.61
	20	31.83	12.39	14.18	15.96	17.75	19.49	21.23	22.92	24.39	26.03	27.65	29.21
	21	32.69		12.31	14.12	15.89	17.66	19.40	21.16	22.87	24.31	25.98	27.58
	22	33.67			12.23	14.04	15.83	17.59	19.35	21.06	22.79	24.21	25.89
35	16	27.73	19.03	20.78	22.23	23.89	25.42	26.91					
	17	27.95	17.26	18.99	20.73	22.21	23.85	25.47	26.97	28.18			
	18	28.71	15.44	17.20	18.95	20.69	22.15	23.81	25.45	27.00	28.42		
	19	29.50	13.63	15.38	17.17	18.91	20.66	22.09	23.78	25.43	27.01	28.50	29.77
	20	30.29	11.76	13.56	15.34	17.10	18.85	20.58	22.30	23.74	25.36	26.97	28.51
	21	31.11		11.69	13.49	15.28	17.03	18.77	20.50	22.25	23.64	25.33	26.93
	22	32.03			11.62	13.43	15.19	16.95	18.69	20.44	22.16	23.59	25.24
40	16	26.46	18.32	19.81	21.48	23.12	24.64	25.92					
	17	26.48	16.55	18.28	20.00	21.46	23.10	24.68	26.14				
	18	27.14	14.75	16.50	18.26	19.99	21.41	23.08	24.69	26.22	27.51		
	19	27.85	12.91	14.68	16.45	18.19	19.92	21.38	23.04	24.68	26.24	27.64	
	20	28.53	11.05	12.84	14.65	16.39	18.15	19.87	21.34	23.00	24.61	26.22	27.73
	21	29.35		11.01	12.79	14.56	16.32	18.08	19.80	21.53	22.95	24.58	26.18
	22	30.22			10.91	12.72	14.51	16.26	18.02	19.74	21.45	22.89	24.52
45	16	25.03	17.55	19.06	20.68	22.31	23.73						
	17	25.04	15.79	17.52	19.03	20.65	22.30	23.79					
	18	25.40	13.99	15.76	17.49	19.00	20.64	22.29	23.87				
	19	26.08	12.18	13.96	15.71	17.45	19.17	20.62	22.27	23.87	25.34		
	20	26.72	10.34	12.11	13.91	15.66	17.40	19.12	20.59	22.21	23.83	25.39	26.76
	21	27.52		10.27	12.07	13.84	15.61	17.34	19.08	20.54	22.18	23.78	25.40
	22	28.29			10.20	12.02	13.77	15.55	17.29	19.01	20.48	22.15	23.77
50	16	23.48	16.71	18.21	19.82	21.39	22.67						
	17	23.49	14.98	16.71	18.20	19.82	21.41	22.80					
	18	23.50	13.19	14.93	16.67	18.17	19.79	21.41	22.91				
	19	24.18	11.39	13.14	14.89	16.64	18.14	19.78	21.41	22.96	24.29		
	20	24.71	9.54	11.34	13.10	14.86	16.59	18.30	19.75	21.36	22.94	24.40	
	21	25.43		9.51	11.28	13.05	14.80	16.54	18.24	19.71	21.33	22.92	24.47
	22	26.15			9.44	11.21	12.47	14.75	16.49	18.19	19.68	21.28	22.90

## HEATING PERFORMANCE

WB TEMP ON OD COIL - °C	HEATING CAPACITY - kW									
	AT DB ENTERING INDOOR - °C									
	16		18		20		22		24	
	TH	IH	TH	IH	TH	IH	TH	IH	TH	IH
-10	18.17	17.44	18.08	17.36	17.98	17.26	17.90	17.19	17.81	17.10
-8	19.20	18.24	19.10	18.14	18.99	18.04	18.89	17.94	18.79	17.85
-6	20.28	19.06	20.16	18.95	20.04	18.83	19.91	18.72	19.78	18.59
-4	21.44	19.73	21.30	19.59	21.15	19.46	21.02	19.34	20.87	19.20
-2	22.64	20.15	22.48	20.01	22.32	19.87	22.16	19.72	22.00	19.58
0	23.93	21.06	23.76	20.91	23.58	20.75	23.41	20.60	23.23	20.44
2	25.17	22.90	24.98	22.73	24.78	22.55	24.58	22.36	24.38	22.18
4	26.50	26.50	26.27	26.27	26.06	26.06	25.84	25.84	25.60	25.60
6	27.87	27.87	27.63	27.63	27.40	27.40	27.23	27.23	26.98	26.98
8	29.36	29.36	29.19	29.19	28.93	28.93	28.66	28.66	28.38	28.38
10	31.02	31.02	30.74	30.74	30.45	30.45	30.16	30.16	29.85	29.85
12	32.66	32.66	32.34	32.34	32.03	32.03	31.71	31.71	31.38	31.38
14	34.37	34.37	34.03	34.03	33.67	33.67	33.33	33.33	32.97	32.97
16	36.13	36.13	35.76	35.76	35.38	35.38	34.99	34.99	34.62	34.62
18	37.96	37.96	37.55	37.55	37.15	37.15	36.75	36.75	36.32	36.32

TH - Total Heating Capacity (kW).  
IH - Integrated Heating Capacity (kW).  
Includes defrost losses.

## AIRFLOW CORRECTION MULTIPLIER

% VARIATION	-15%	-10%	-5%	NOMINAL	+5%	+10%
INDOOR AIRFLOW (l/s)	1275	1350	1425	1500	1575	1650
TOTAL COOLING	0.972	0.982	0.991	1.00	1.008	1.014
SENSIBLE COOLING	0.919	0.947	0.973	1.00	1.027	1.053
HEATING FACTOR	0.991	0.994	0.997	1.00	1.002	1.004

### NOTES:

- No allowance has been made for the effect of indoor fan motor.
- Selection tables are based on nominal airflows.  
Correction factors must be applied for selection away from these conditions.



AIRFLOW (l/s)	EXTERNAL STATIC PRESSURE (Pa)											
	50		100		150		200		250		300	
	% PWM	W	% PWM	W	% PWM	W	% PWM	W	% PWM	W	% PWM	W
1275	---	---	---	---	53	801	57	924	62	1093	MOTOR / BLOWER LIMIT	
1300	---	---	---	---	54	810	58	947	63	1112		
1350	---	---	52	741	57	870	61	1012	66	1178		
1400	51	677	55	776	60	922	64	1070	69	1245		
1450	54	709	58	838	63	989	67	1141	73	1312		
<b>1500</b>	57	762	<b>61</b>	<b>902</b>	66	1052	70	1214	76	1380		
1550	60	838	65	972	69	1132	74	1298	80	1458		
1600	64	899	68	1042	73	1211	78	1375	84	1528		
1650	67	979	72	1132	77	1300	82	1458	88	1676		

**NOTES:**

**W** = Indoor Fan Power, Watts

**PWM** = Pulse Width Modulation Setting, % PWM

(Adjustable through CPI3-1 Board located in electrical panel).

Factory PWM Setting = 61 % PWM for 100 Pa.

   - Data in the box indicates Factory Default Setting.

**(CPI3-1) COMMERCIAL PWM INTERFACE BOARD**

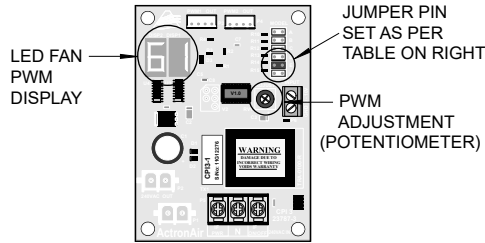

JUMPER PIN POSITION	INDOOR FAN
A	SCG400E PCG400U/L/R
B	PCG340L/R
C	PCG330L/R
D	PCG300L/R
E	SCG290E PCG290U/L/R
F	NOT USED

**NOTES:**

- LED will show PWM without %.
- Example: 61% PWM = 61 in LED.
- LED adjustments are in 1 digit increment.

**3 Phase 1 Stage 29.50 kW**

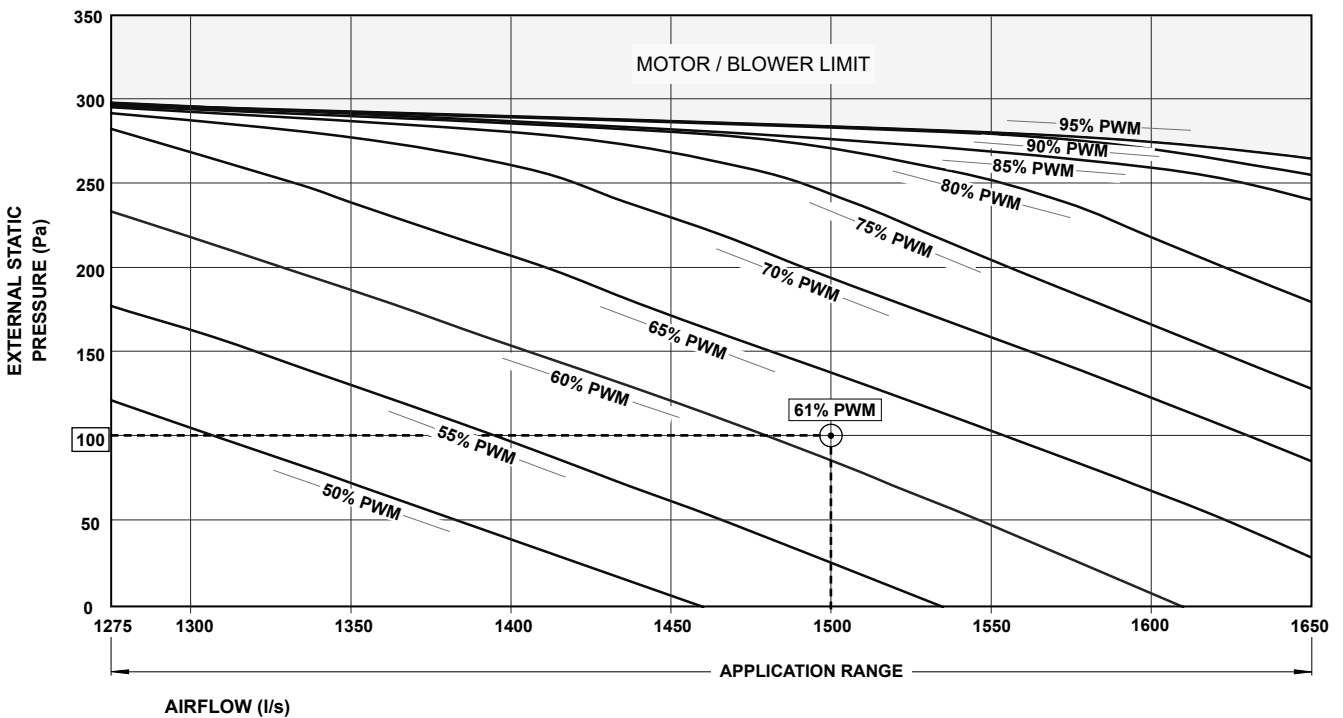

Nominal Airflow = 1500 l/s



## PACKAGE UNIT - WITH LEFT HAND AIR SUPPLY OPTION

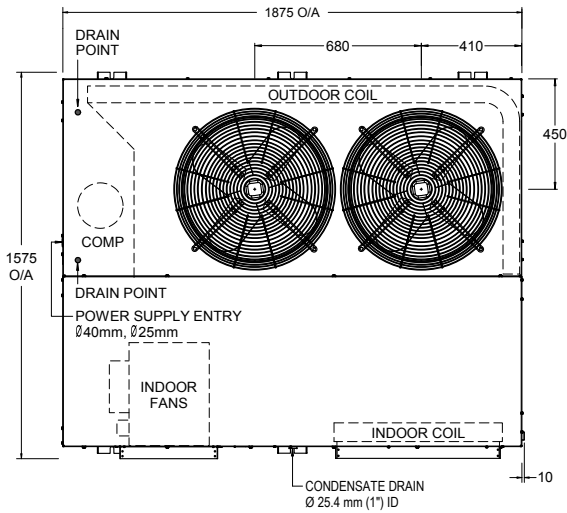

**TOP VIEW**

OVERALL NOMINAL DIMENSION (H x W x L)  
 = 1330 x 1875 x 1575  
 SUPPLY DUCT (H x W) = 830 x 400  
 RETURN DUCT (H x W) = 850 x 670  
 USE M12 BOLT FOR FEET MOUNTING

**NOTES:**

1. All dimensions are in mm unless specified.
2. Do not scale drawing.
3. Additional Full Coil Coat Protection option available on all units.
4. Suggested Service Clearance and Airflow Allowances are based on conditions that the spaces are free from obstructions and walkway passage of 1000mm is available.
5. Minimum service access areas are responsibilities of the installer.

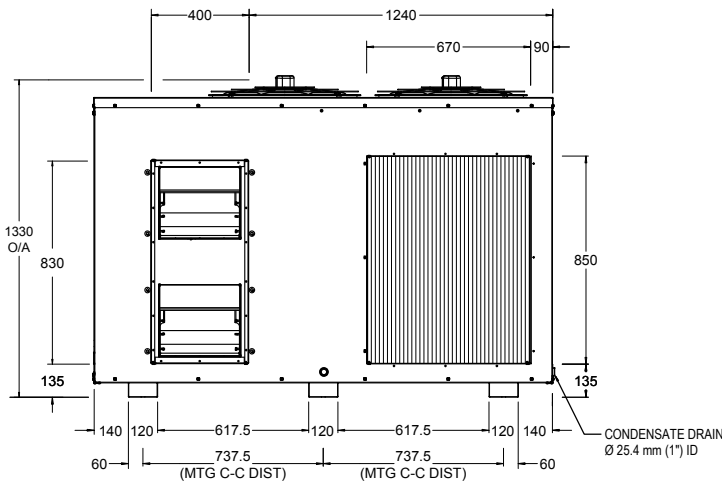
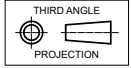

**FRONT VIEW**

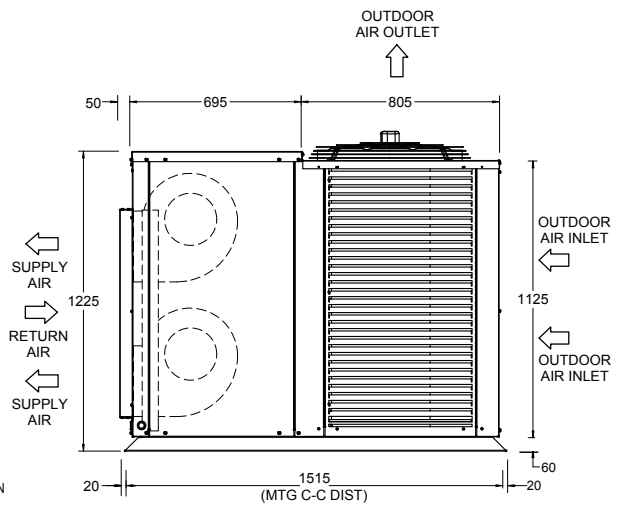

**SIDE VIEW**

**29.50 kW**  
**3 Phase 1 Stage**

UNIT MODEL NUMBER	UNIT WEIGHT (kg)	CORNER WEIGHTS (kg)					
		LF	RF	LR	RR	LM	RM
PCG290L	450	120.8	126.6	67.2	53.6	37.0	44.8

### MINIMUM SERVICE ACCESS CLEARANCES & AIRFLOW SPACE ALLOWANCES

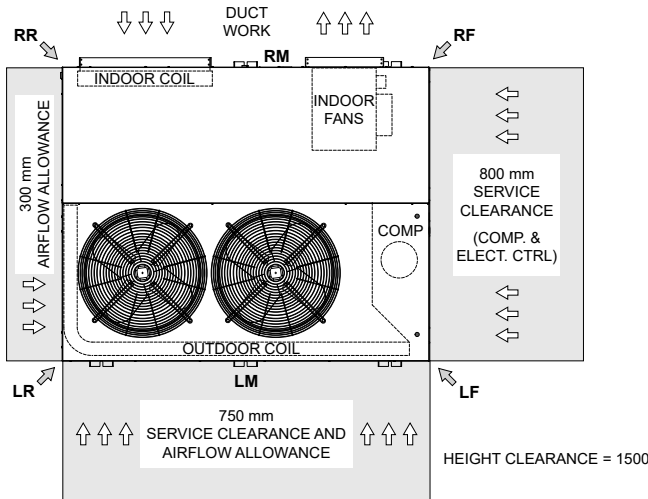

**PLEASE NOTE THAT UNDER ALL CIRCUMSTANCES, CONDENSER AIR MUST NOT RECIRCULATE BACK ONTO CONDENSER COIL. KEEP ALL CLEARANCES FREE OF ANY OBSTRUCTIONS**

STACKING OF UNITS	
ONE IN FRONT OF THE OTHER (DISTANCE BET. LF & RF)	SIDE BY SIDE (DISTANCE BET. LF & LR)
1000 mm	1000 mm



# UNIT DIMENSIONS

# PCG290R

## R PACKAGE UNIT - WITH RIGHT HAND AIR SUPPLY OPTION

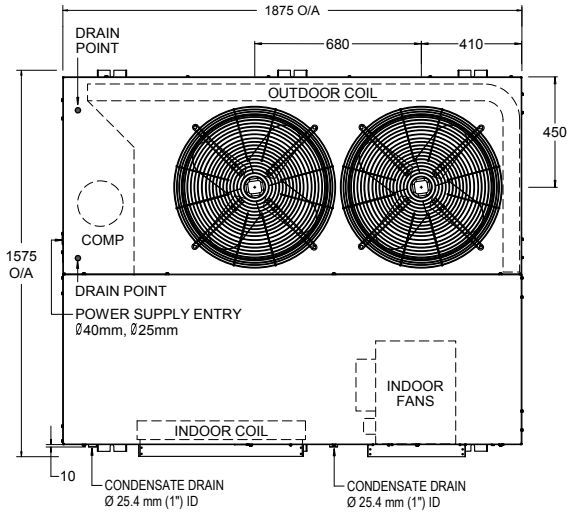

TOP VIEW

OVERALL NOMINAL DIMENSION (H x W x L)  
 = 1330 x 1875 x 1575  
 SUPPLY DUCT (H x W) = 830 x 400  
 RETURN DUCT (H x W) = 850 x 670  
 USE M12 BOLT FOR FEET MOUNTING

**NOTES:**

1. All dimensions are in mm unless specified.
2. Do not scale drawing.
3. Additional Full Coil Coat Protection option available on all units.
4. Suggested Service Clearance and Airflow Allowances are based on conditions that the spaces are free from obstructions and walkway passage of 1000mm is available.
5. Minimum service access areas are responsibilities of the installer.

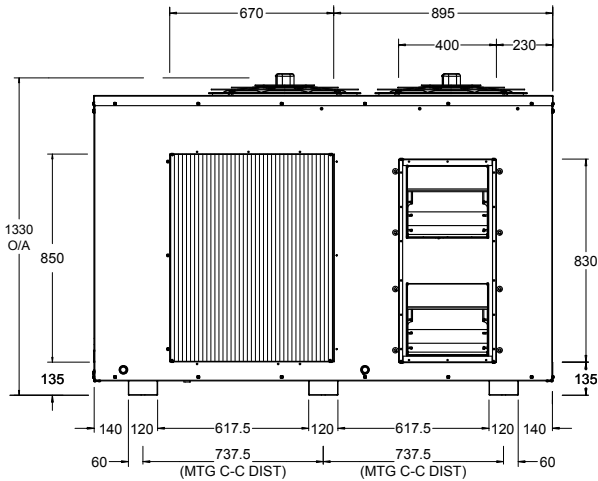
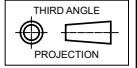

FRONT VIEW

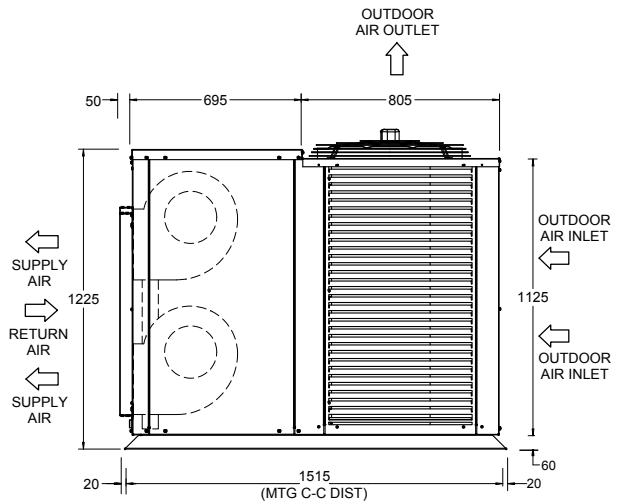

SIDE VIEW

3 Phase  
 1 Stage  
 29.50 kW

UNIT MODEL NUMBER	UNIT WEIGHT (kg)	CORNER WEIGHTS (kg)					
		LF	RF	LR	RR	LM	RM
PCG290R	450	120.8	53.6	67.2	126.6	37.0	44.8

### MINIMUM SERVICE ACCESS CLEARANCES & AIRFLOW SPACE ALLOWANCES

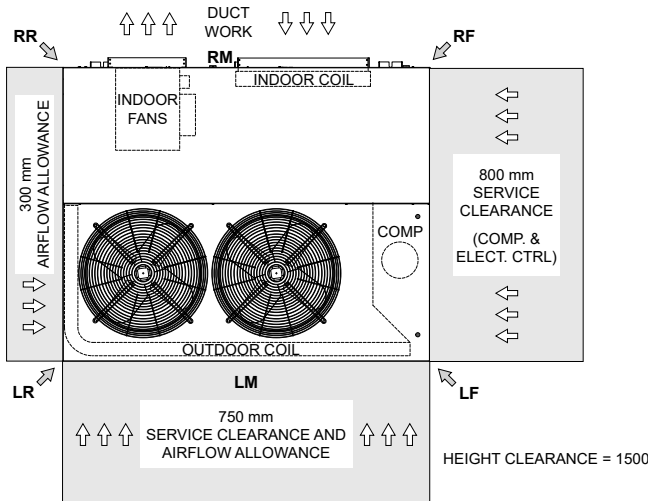

PLEASE NOTE THAT UNDER ALL CIRCUMSTANCES, CONDENSER AIR MUST NOT RECIRCULATE BACK ONTO CONDENSER COIL. KEEP ALL CLEARANCES FREE OF ANY OBSTRUCTIONS

STACKING OF UNITS	
ONE IN FRONT OF THE OTHER (DISTANCE BET. LF & RF)	SIDE BY SIDE (DISTANCE BET. LF & LR)
1000 mm	1000 mm



**Outdoor Radiated**

**Sound Power Level (SWL)**

Fan Speed	Sound Power Level dB(A)	Octave Band Centre Frequency (Hz), dB						
		125	250	500	1k	2k	4k	8k
Low	73.9	72.1	71.9	71.5	68.5	65.1	64.1	60.6
High	77.9	75.9	75.7	75.2	72.5	69.5	67.9	64.6

**Indoor Outlet**

**Sound Power Level (SWL)**

Airflow Setting	Airflow Li/s	Sound Power Level dB(A)	Octave Band Centre Frequency (Hz), dB						
			125	250	500	1k	2k	4k	8k
Nominal	1500	76.1	74.0	71.1	72.3	71.5	68.7	66.3	60.1

**29.50 kW**  
**3 Phase 1 Stage**

**OUTDOOR RADIATED**

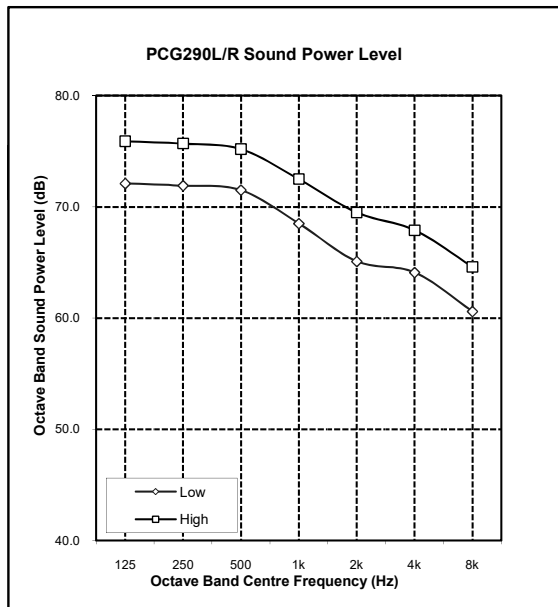

**INDOOR OUTLET**

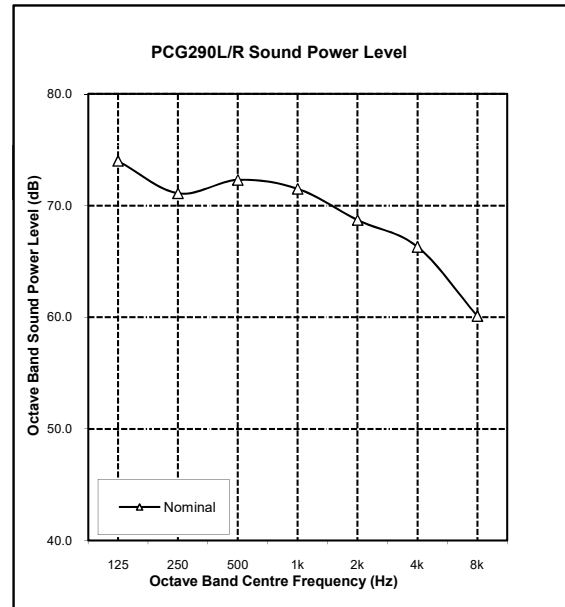

**NOTES:**

1. Radiated sound power levels are based on ISO 3743-2.
2. Outlet sound power levels are based on ISO 13347-2.



# SPECIFICATIONS

# PCG290L/R

CONSTRUCTION	
CABINET BASE	1.9 mm Galvanised Steel
CABINET TOP AND SIDES	0.9 - 1.6 mm Galvanized Steel
SURFACE FINISH	65 microns Baked Polyester Powder Coat

INSULATION	
TYPE	10 mm Foil Faced Polyethylene 20 mm Expanded Polystyrene

SOUND LEVEL * dB(A)	
SOUND PRESS. - Low / High	55.9 / 59.9 @ 3m Distance
SOUND POWER LEVEL - Low / High	72.9 / 76.9
* Sound data are based on outdoor fan's manufacturer sound level data.	

ELECTRICAL	
POWER SUPPLY - 50 Hz	400 Volts x 3 Phase + Neutral
VOLTAGE RANGE (min - max)	380V - 440V
FULL LOAD AMPS * - Phase 1	30.9
FULL LOAD AMPS * - Phase 2 & 3	16.3 & 17.1
RATED LOAD AMPS**	24.5
APPROX. STARTING AMPS	111.0
IP RATING	IP44
IMPORTANT - The local electricity authority may require limits on starting current and voltage drop, please check prior to purchase.	
* Full Load Amps are based on compressor and fan motor's maximum expected current.	
** Rated Load Amps are measured and tested in accordance with AS/NZS3823.1.2.	

CABLE SIZE & CIRCUIT BREAKER SIZE	
Suggested minimum cable size should be used as a guide only, refer to AS/NZS 3000 "Australian/New Zealand Wiring Rules" for more details.	
CABLE SIZE (MAIN LINE)	6.0mm <sup>2</sup> (SUGGESTED MINIMUM)
CIRCUIT BREAKER SIZE - AMPS	32.0

OUTDOOR COIL	
TUBE TYPE	Copper - Rifle Bore
FIN TYPE	Aluminium - Wave
FACE AREA (m sqr)	2.51
FIN SPACING (per m)	630
COIL COATING	Blue Epoxy Coat Coil Fin Protection
ROWS	---

OUTDOOR FAN	
NUMBER OF FANS x TYPE	2 x Axial
NUMBER OF BLADES PER FAN	4
DIAMETER (mm)	560
OUTPUT kW	0.37
MOTOR TYPE / DRIVE TYPE	6 Pole External Rotor / Direct Drive
FAN SPEED CONTROL	2 Speed via Capacitor
The standard type outdoor fans fitted to this unit will accept up to 5Pa of external static resistance.	

INDOOR COIL	
TUBE TYPE	Copper - Rifle Bore
FIN TYPE	Aluminium - Louvre
FACE ARE (m sqr)	0.863
FIN SPACING (per m)	472
COIL COATING	Blue Epoxy Coat Coil Fin Protection
ROWS	---

INDOOR FAN	
NUMBER OF FANS x TYPE	2 x Centrifugal EC Fan
DIAMETER / WIDTH (mm)	270 x 270
OUTPUT kW / INPUT kW	1.12 / 1.26
MOTOR TYPE / DRIVE TYPE	Variable Speed EC Motor / Direct

COMPRESSOR	
NUMBER PER UNIT x TYPE	1 x Scroll (Hermetic)
FULL LOAD AMPS	16.7
LOCKED ROTOR AMPS	111.0
STARTING METHOD	D.O.L. (optional soft starter)

REFRIGERATION SYSTEM	
REFRIGERANT TYPE	R-410A
EXPANSION CONTROL	Direct Expansion Orifice
FACTORY CHARGE (grams)	10,475

FILTER DRIER	
CONNECTION SIZE & TYPE	15.9 mm (5/8") ODF Soldered Bi-Flow
FACTORY SUPPLIED / FITTED	No
See Installation Section for complete Filter Drier specifications.	

PROTECTION DEVICES	
HIGH PRESSURE CUTOFF SWITCH	Nonadjustable (Automatic Reset)
LOW PRESSURE CUTOFF SWITCH	Nonadjustable (Automatic Reset)
COMPRESSOR MOTOR TEMP.	Internal Thermal Cut-Out
INDOOR FAN OVERLOAD	Internal Thermal Cut-Out
OUTDOOR FAN OVERLOAD	Internal Thermal Cut-Out
SUMP HEATER WATTS	50.0 W during Comp. Off Cycle

ELECTRIC CONTROLS	
DEFROST METHOD	Reverse Cycle
DEFROST TYPE	Adaptive Demand Defrost
CONTROL CIRCUIT BREAKER	16.0 Amps
C7-4 FIELD CONTROL WIRING	2 Core 14 / 0.20 Screened Cable

OPERATING RANGE	
It is essential that the unit is correctly sized for the application and operates within its recommended range of operating conditions as shown below.	

MODE	RANGE	INDOOR AIR INTAKE TEMPERATURE	OUTDOOR AIR INTAKE TEMPERATURE
		30°C DB / 22°C WB	50°C DB
Cooling	Max.	30°C DB / 22°C WB	50°C DB
	Min.	20°C DB / 16°C WB	15°C DB
Heating	Max.	24°C DB	19.5°C DB / 18°C WB
	Min.	16°C DB	-10°C WB

IMPORTANT - For low ambient cooling use option S. Lower ambient available on request. Contact your nearest ActronAir office for more details.

Low Ambient Cooling	Option S	Max.	29°C DB / 19°C WB	50°C DB
		Min.	20°C DB / 15°C WB	5°C DB
	On Request	Max.	29°C DB / 19°C WB	50°C DB
		Min.	20°C DB / 15°C WB	-5°C DB

AIR FILTERS	
All return air including fresh air must have adequate filters supplied and fitted by the installing contractor. Filters must be located in accessible location between the return air grille and the unit.	
ActronAir™ does not supply or make any provisions for return air filter.	

3 Phase  
1 Stage  
29.50 kW



# WIRING DIAGRAM

# PCG290L/R

LEGEND	
CB	CIRCUIT BREAKER
CCH	CRANKCASE HEATER
CM	COMPRESSOR MOTOR
CMC	COMPRESSOR MOTOR CONTACTOR
CPI	INDOOR FAN VARIABLE SPEED BOARD
ECM	EC FILTER
HCT	HIGH SPEED FAN CONTACTOR
HP	HIGH PRESSURE SWITCH
IF	INDOOR FAN MOTOR
LCT	LOW SPEED FAN CONTACTOR
LP	LOW PRESSURE SWITCH
LSC	LOW SPEED CAPACITOR
OF	OUTDOOR FAN MOTOR
OCB	OUTDOOR CONTROL BOARD
PFC	POWER FACTOR CORRECTION CAPACITORS
PFCC	POWER FACTOR CORRECTION CONTACTOR
RV	REVERSING VALVE
TERM	MAIN TERMINAL BLOCKS
WC	WALL CONTROLLER

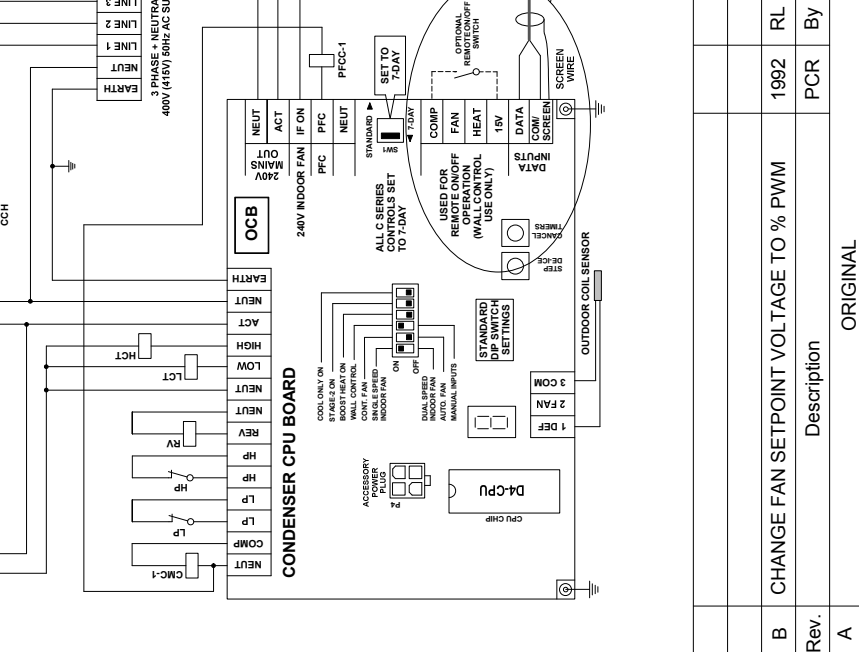
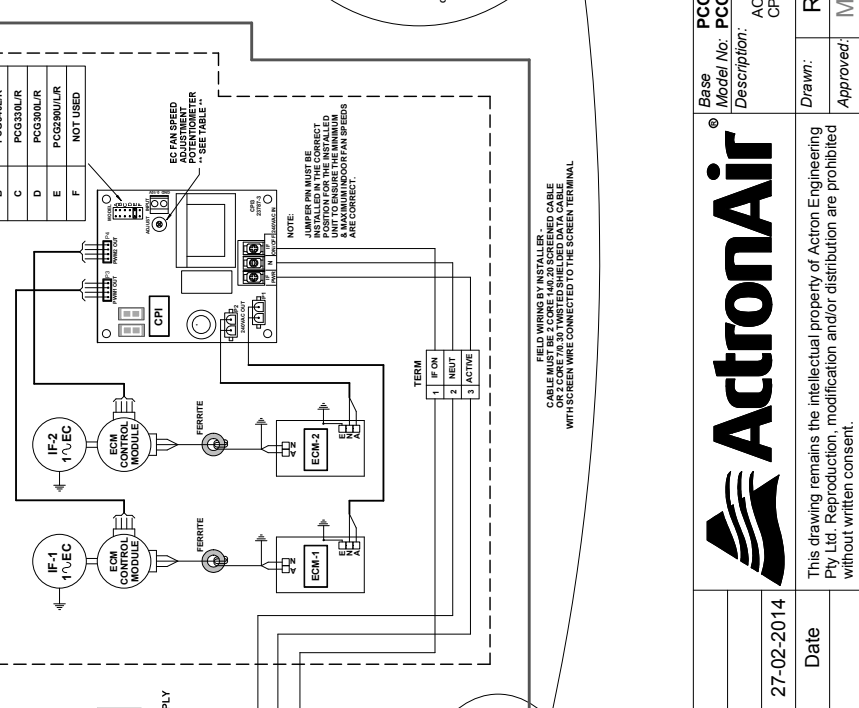
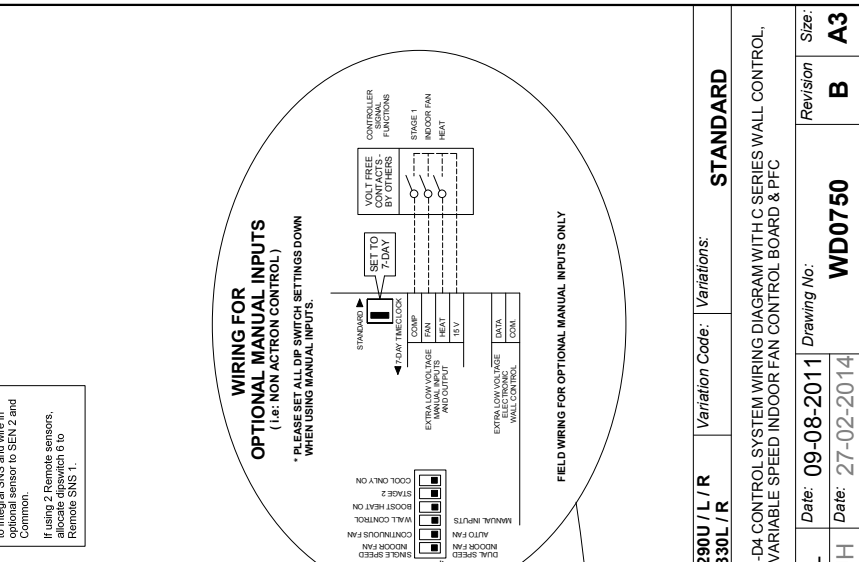
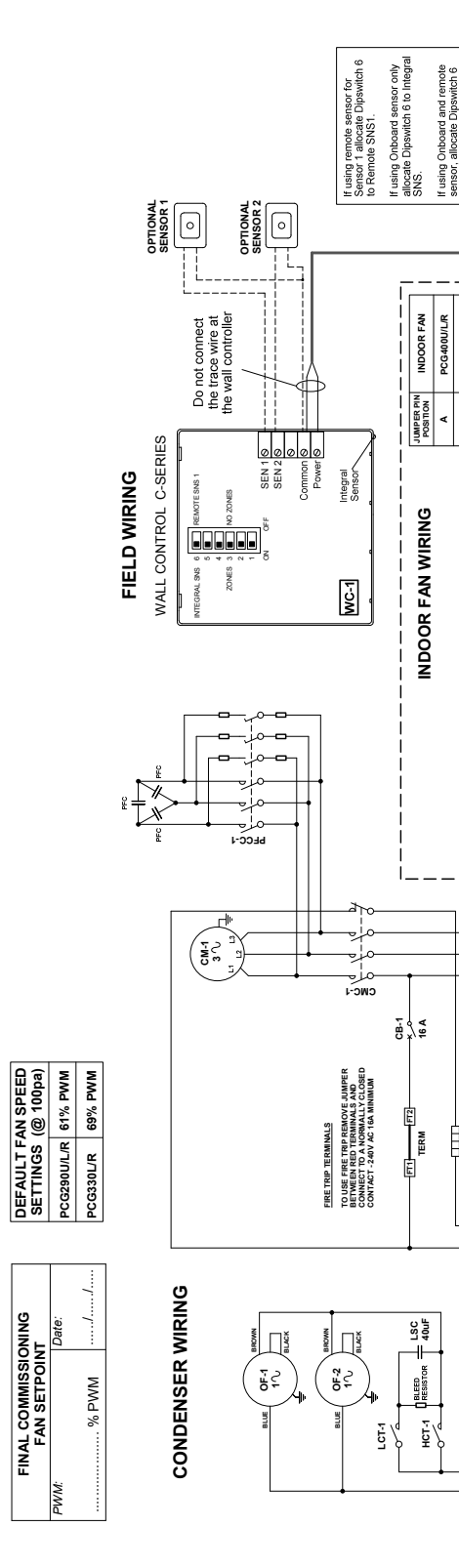

FINAL COMMISSIONING FAN SETPOINT	
PWM:	% PWM
Date:	...../...../.....

Base Model No:	PCG290U / L / R	Variation Code:	STANDARD
Description:	ACT-D4 CONTROL SYSTEM WIRING DIAGRAM WITH C SERIES WALL CONTROL, CPI VARIABLE SPEED INDOOR FAN CONTROL BOARD & PFC		
Drawn:	RL	Date:	09-08-2011
Approved:	MJH	Date:	27-02-2014
Revision:	B	Size:	A3



**ActronAir**

This drawing remains the intellectual property of Actron Engineering Pty Ltd. Reproduction, modification and/or distribution are prohibited without written consent.

Rev.	Description	By	Date
B	CHANGE FAN SETPOINT VOLTAGE TO % PWM	PCR	1992
A	ORIGINAL	PCR	27-02-2014